

Design of a Long-term Monitoring System for a PSC Continuous Box-girder Bridge

Chen Chuang^{1,2,a}, Mosbeh R.Kalooop^{1,3,b}, Wang Zonglin^{1,c},
Gao Qingfei^{1,d}, and Zhong Junfei^{1,e}

¹School of Transportation Science and Engineering, Harbin Institute of Technology, Harbin, China, 150090

²Department of Civil and Environmental Engineering, Rutgers University, Piscataway, U.S., 08854

³Public Works and Civil Engineering Department, Mansoura University, Mansoura, Egypt, 35516

^achuang0925@hotmail.com, ^bmosbeh.kalooop@gmail.com, ^cwangzonglin@vip.163.com
^dgaoqingfei1986@gmail.com, ^ekranyi@163.com

Keywords: Structural health monitoring system; static and dynamic responses; PSC continuous box-girder bridge; hydrostatic leveling system; fiber Bragg grating

Abstract. Structural Health Monitoring is becoming an increasingly common tool to obtain the long-term performance of infrastructures and buildings. Many structural health monitoring systems were developed and applied to different bridges in the world. However, very little is known on the applications in extreme cold environment. Fu Sui Bridge, a 1070 m variable cross-section continuous box-girder bridge, is located in the coldest province -- Heilongjiang province, China. In order to monitor the static and dynamic responses of the bridge under the traffic and environmental variation, a long-term continuous monitoring system was designed and installed on Fu Sui Bridge in April 2012. A hydrostatic leveling system was used to measure the displacement and fiber Bragg grating sensors were used to measure strain, acceleration and temperature. Moreover, other necessary components including data acquisition and transmission, data calculation and analysis software are also described. Summer and winter monitoring data are also presented. This paper focuses on: (1) the design and installation of the long-term continuous monitoring system hardware and (2) the operating pattern and function of the automatic monitoring system. After more than one year successful conducting, the system has provided a large amount of data records for daily management and research of the bridge. This system can be applied to extremely cold region.

1 Introduction

Long-scale prestressed concrete (PSC) continuous box-girder bridges are universally undergoing the overlarge deformation and cracks with the shortage lifecycle due to long-term overload, loss of prestress and environmental factors. Untimely inspection and maintenance may generate potential society risks. Previous studies suggest that structural health monitoring (SHM) system could be used to obtain the long-term continuous information of the bridges so as to assess the condition and identify the damage [1]. There are many advantages of a SHM system include early warning if a bridge becomes unsafe, the capability to locate and quantify damage in a bridge, and better targeting of maintenance resources by identifying which structures most need maintenance [2]. Long-term continuous monitoring is one strategy of SHM. In this case, deformation, strain, acceleration and temperature of a bridge and the traffic and environmental variations can be measured and recorded. These basic records can be determined to use for bridge condition assessment.

SHM system aims to acquire static and dynamic responses [3-5], identify the damage [6] and analyze the responses under the environmental variation [7, 8] for PSC continuous box-girder bridges. However, monitoring results can be quite variable with environmental variation.

Temperature is the most common environmental factor which can influence the modal parameter and deformation [9]. Studies have revealed that frequencies are sensitive to temperature variation [10, 11]. The nature frequency can fluctuate to 10% with different temperature [12]. Consequently, a monitoring system must be able to recognize the changes by eliminating or segregating the environmental effect to determine the accuracy and reliability of the responses.

Fu Sui Bridge is located in Heilongjiang province, China. The bridge crosses Songhua River and connects two towns of Fu Jin and Sui Bin. The temperature in this region varies greatly all over the. The temperature can reach up to 30 °C in summer whereas it can fall down to -30 °C in winter. This study presents the details of a long-term continuous monitoring system deployed on Fu Sui. The system includes two isolated sensor subsystems (hydrostatic leveling subsystem (HLS) is used to measure displacement; fiber Bragg grating (FBG) subsystem is used to measure strain, acceleration and temperature), data acquisition and transmission subsystem, master control center, remote control center, data analysis and processing software and the power supply system. The design, installation and software are illuminated in details. The monitoring system has been operating over one year and it will continue to provide the live data for management and research.

2 Bridge Description

Fu Sui Bridge, total 1170 m long, is a PSC continuous box-girder bridge located in Heilongjiang province, China (Fig.1. (a)). It crosses the Song Hua River and connects two towns: Fu Jin and Sui Bin. The bridge is consisted of eight continuous spans of 85.00 m, 6*150 m, 85.00 m. The main girder, cast-in-place, post-tensioned segmental structure has a single-cell box cross section, with the height varying from 9 m (over pier section) to 3.5 m (mid-span section), including 11.25 m width of top slab, 5.85 m width of bottom slab and 2.7 m length of flange slab on each side.

The mid span and pier top sections are shown in Fig.1 (b). The web thickness ranges from 100 cm to 55 cm, and bottom slab thickness ranges from 150 cm to 30 cm. Cast-in-place cantilever construction method was applied for superstructure construction. The length of cantilever arms is 74 m for each side, which is divided into 19 segments (#0 to #18) with difference length. During the construction, after the piers were done, segments #0 to #18 were constructed symmetrically by travelers, and then closure segment of side span was casted, finally the mid-span closure segment was casted in the middle span.

The entire construction of Fu Sui Bridge lasted approximately three years from 2008 to 2011. At the bridge site area, the winter is extremely cold and no outdoor work can be done during November to the following April. The monitoring system was designed just after the bridge opened and conducted the installation in the middle of April 2012. The entire monitoring system construction includes a six kilometers optical cable burying, sensors and data acquiring devices installation and a three kilometers current cable setting up along the bridge.



(a)

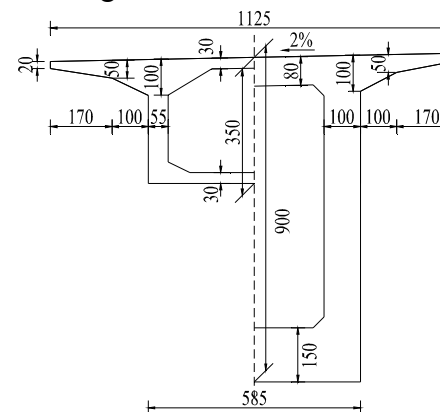

(b)

Fig.1 (a) the view of Fu Sui Bridge and (b) the mid span section and the pier top section

3 Monitoring System

A long-term continuous monitoring system has been designed and installed on Fu Sui Bridge to detect the damage and assess the condition, as well as to monitor the long-term static and dynamic performance undergoing to the traffic and the environmental influences. SHM system is composed of HLS sensor subsystem, FBG sensor subsystem, data acquisition and transmission subsystem, master control center, remote control center, data analysis and processing software and the power supply system.

SHM system of Fu Sui Bridge is shown in Fig.2. In this system, HLS is used to measure static displacement and FBG sensor subsystem is used to measure the temperature, strain and acceleration. The data acquisition system, as the core component, in the Bridge Management Station (MBS), is six kilometers far from the bridge site. An eight cores single-mode fiber cable is used for communicating among the devices and sensors. The master control center and remote control center are responsible for the management of the system. Primary data calculation and analysis is processed in the master control center by the software, which can provide timely information for the bridge administrative staff. Moreover, the remote center can log in the software and use analytical results for further research.

The sensor position of the SHM system is shown in Fig.3. Total 24 strain sensors distributed to six sections were installed on the surface of top and bottom plates. Each strain section had a temperature sensor to identify the longitudinal temperature difference and also as a sort of compensation. Four uniaxial acceleration sensors were installed in the four mid-spans of the bridge to acquire the dynamic data. And extra six temperature sensors are applied on one section inside and outside of the box-girder to monitor the temperature difference.

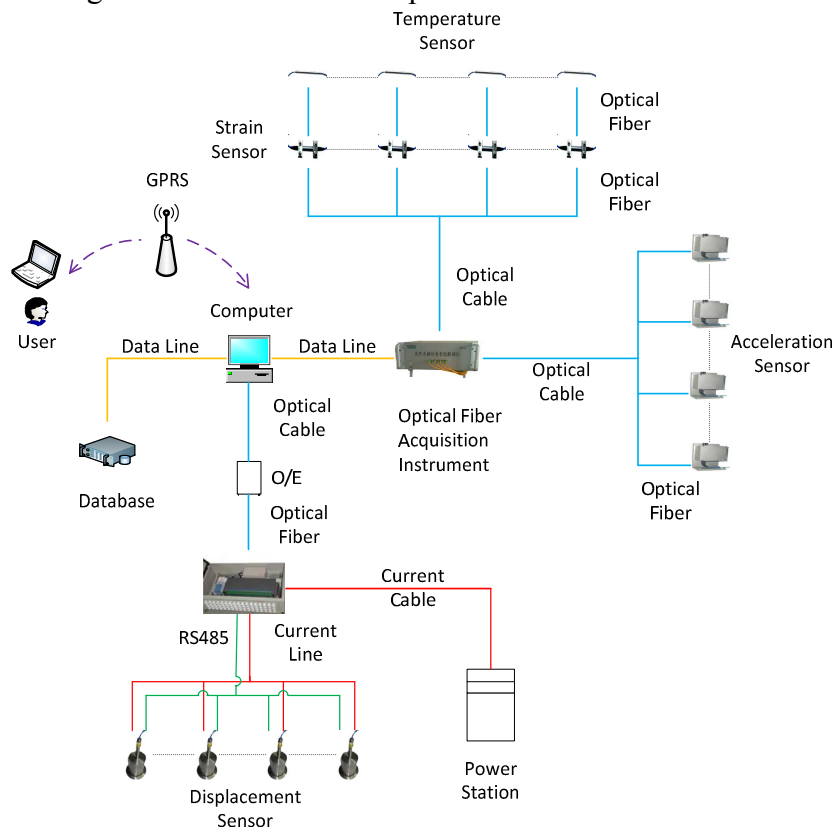

Fig.2 SHM system of Fu Sui Bridge

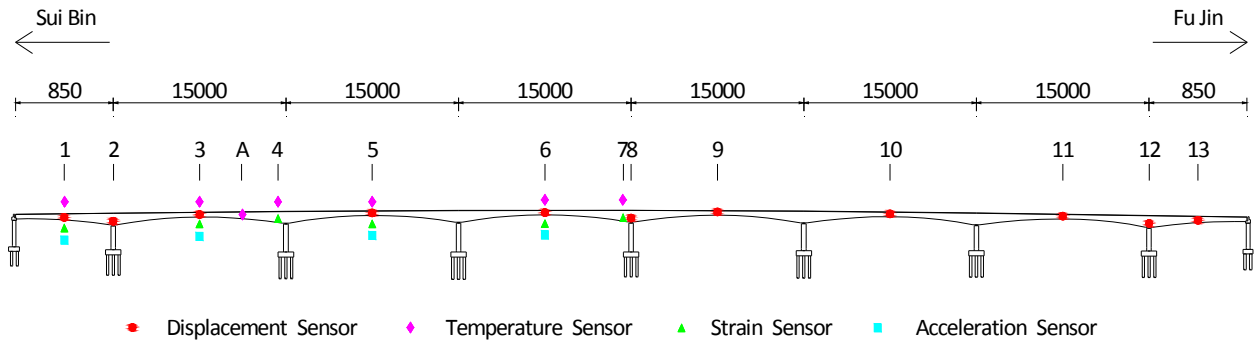

Fig.3 Sensor position of SHM system of Fu Sui Bridge

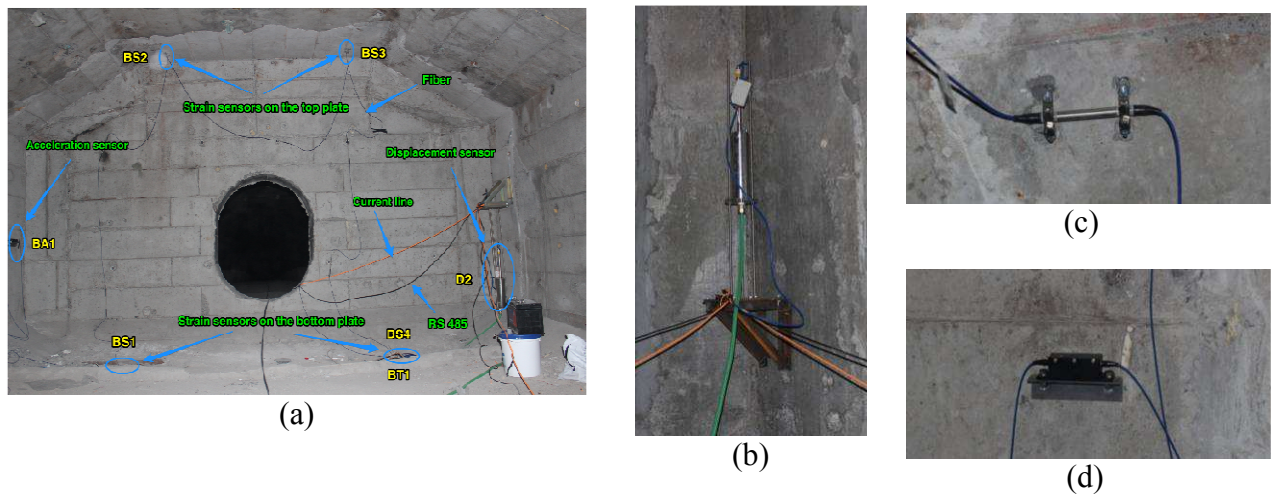

Fig.4 (a) the view of sensors on the mid span section, (b) the view of the HLS sensor, (c) the view of the accelerometer and (d) the view of the strain sensor

3.1 Hydrostatic Leveling system

Hydrostatic Leveling System is widely used in long-term monitoring of structure displacement [13], also including the application of extreme climate conditions [14] because of its high resolution, large range measurement, low cost of installation and maintenance [15]. HLS is applied for displacement measurement. The basic principle of HLS is the communicating tube theory--using the property that liquid in interconnected container always desires to keep on the same plane. The measurement values of the displacement are obtained by measuring the relative displacement changes of the liquid level.

HLS of Fu Sui Bridge was manufactured by Changsha Jinma Hightechnics co., LTD. Model JMDL-62AD hydrostatic leveling sensor was selected to measure the displacement. The sensor ranged from 0 mm to 200 mm, accuracy of 0.01 mm. The sensors were mounted on the mid span and the pier top sections. In this case, it was not possible to measure the entire displacement by one network due to the longitudinal slope. Therefore, three networks were installed with two leveling sensors at different height in one section to ensure the detectable values not exceeding the measurement range of the sensor.

Fig.4 (b) represents the HLS sensor with current line, RS 485 line and transparent tubing. The mounted position on the web was determined according to the drafts of the bridge. The longitudinal slope was taken into account to ensure that the liquid level could keep in the same plane. The

double triangle steel bracket with a steel flat plate on the bottom was mounted via four expansion screws into the web. Three thread holes were made in the flat plate. The relative thread steel bars, one meter long, could be fixed through setting two crews on both sides of the flat plate. HLS sensor was fixed on the three bars on the original height. The current line, RS 485 line and transparent tubing were connected among the sensors. Antifreeze fluid was selected to pour into the tubing due to long-term extremely low temperature in winter ($< 0\text{ }^{\circ}\text{C}$). Air bubbles in the tubing must be removed because the bubbles could prevent and damp the liquid flowing. According to the measured value, the sensor height was set in the final position.

Model JMBV-1164 master control device (MCD), as a core component of HLS, is located in the middle of the box-girder. It is directly connected to the computer of master control center through the optical cable. MCD is also the master management component to output data acquisition command, store short-term data and apply power for the master device and sensors.

3.2 Fiber Bragg Grating sensor subsystem

Fiber Bragg Grating (FBG) sensors are applied for temperature, strain and acceleration measurement. FBG sensor has been widely used in engineering field since the side-writing technique was invented to fabricate the fiber Bragg gratings in 1989 [16]. The advantages of FBG sensor are: light weight, small size, good durability and used in harsh environment. Another attractive feature of FBG sensor is their inherent ability to serve as both the sensing element and the signal transmission medium, which could be used to conduct the remote structural health monitoring [2].

In this system, acquisition device and sensors are manufactured by Beijing Fbgtech Optoelectronic co., LTD, China. Model FAS-E optical fiber grating intelligent high-speed demodulation instrument was chosen to provide input light source and resolve the sensor output light signal. This series of demodulation instrument is embedded powerful computer with standard RS232 and 10 M Ethernet communication interface. The highest sampling frequency could reach 500 Hz (4 channels). According to calculation results of the finite element modal, the sampling frequency is set to 25 Hz for each sensor.

1) Strain sensors

The monitoring system was designed to measure the strain of mid span and pier top sections. Six sections were selected to install strain sensors because of the funding. Model FSS3211DS surface-mounted strain sensor, as shown in Fig.4 (c), was selected to measure the concrete flexural strain. The operating temperature of the sensor ranges from -30 to $100\text{ }^{\circ}\text{C}$ and the measurement range is from -1500 to $+1500\text{ }\mu\epsilon$. On each section, two sensors were mounted on the bottom plate as well as the top plate via small fixed brackets. Two brackets, $5\text{ cm} \times 1\text{ cm}$, were mounted by expansion bolts according to the length of the strain sensor. The sensor was fixed stable when they were adjusted on appropriate wavelength range.

2) Accelerometers

Accelerometer layout on the mid-span is used to monitor the dynamic performance of the main girder. The modal frequencies and modal mode shapes are obtained through the time and frequency domain analysis. Model FSA uniaxial accelerometers, as shown in Fig.4 (d), were installed on the mid span of the bridge. The operating temperature ranges from -30 to $100\text{ }^{\circ}\text{C}$ and the frequency ranges from 0 to 40 Hz. These sensors were mounted visa machine screws on the iron L-brackets which were fixed on the inside web by expansion bolts.

3) Temperature sensors

The ambient temperature monitoring is particularly important in this region. The climate feature: four distinct seasons and sunlight and seasonal temperature difference, seriously affects the measurement results. The secondary internal force caused by sunlight temperature difference has become the main reason of cracks for PSC continuous box-girder bridges. Besides, the deformation and the modal parameters are related to the temperature. The temperature monitoring is a core component to accurately assess the condition of the bridge.

Model FST2111DS ambient temperature sensor was selected to measure the temperature. Six temperature sensors were respectively mounted at the same sections as strain sensors to measure the box-girder longitudinal temperature changes as well as to provide temperature compensation for strain sensors. Another six temperature sensors were set in one section to monitor internal and external temperature of the box girder.

3.3 Data Acquisition

SHM system was applied to remotely monitor the bridge. Computers and FBG interrogator were placed at the Bridge Management Station (BMS) which was six kilometers far from the bridge site. A 6 km optical cable buried underground along the road was mounted to realize the data remote transmission. There are two modes for data transmission: (1) HLS, entirely inside the box-girder, converts the electrical signal into optical signal as well as to transfer the acquired data to BMS computers through the cable; (2) FBG sensors communicate with the interrogator through the cable. The interrogator can also upload the data to the computers after demodulation processing.

The monitoring system will allow authorized people log in the BMS computers through Internet. People can look up the records and change the system index to control the measurement processing. Computers are responsible for preliminary data calculation, storage and integration.

3.4 Software

Data analysis and processing software was designed by the GUI function of MATLAB to extract the data from the database. The function of software is to manage the monitoring data with the basic functions: measurement data extraction, storage and calculation. Moreover, it needs to compose the data display, condition assessment, alarm system and other functions: (1) shows the basic condition of the bridge; (2) provides the historical data, such as displacement, strain, acceleration and temperature; (3) the preliminary data processing and calculation; (4) evaluates the bridge condition and supplies the assessment level; (5) records the alert time and supplies the alert level according to the exceeding value; (6) provides data analysis reports; (7) resets and updates the software.

4 Results

One day monitoring data, including temperature, strain and acceleration, in Jul. 21 2012 and in winter Jan. 21 2013 is presented in this paper, respectively. Fig.5 (a) and (b) show the temperature variation trend outside and inside the box girder. It can be seen that the outside temperature in fig. 5 (a) is not dramatically rising with the time as well as the fig. 5 (b). It means that day may be not a sunny day. In addition, the temperature inside the girder seems hardly to change all the whole day in winter. Fig. 5 (c) and (d) shows the strain variation of the bottom and the top plate of the section 5. The strain in summer fluctuates more strongly than in winter. It means the concrete girder in winter becomes more “harder” than in summer. It could also be verified by the acceleration data shown in fig. 5 (e) and (f). The vibration amplitude in winter is much lower than in summer.

Fig. 5 (g) shows the displacement variation of section 9 from May 19 to June 3, 2012. It reveals that the displacement is in periodical fluctuation coincident with the day and night shift.

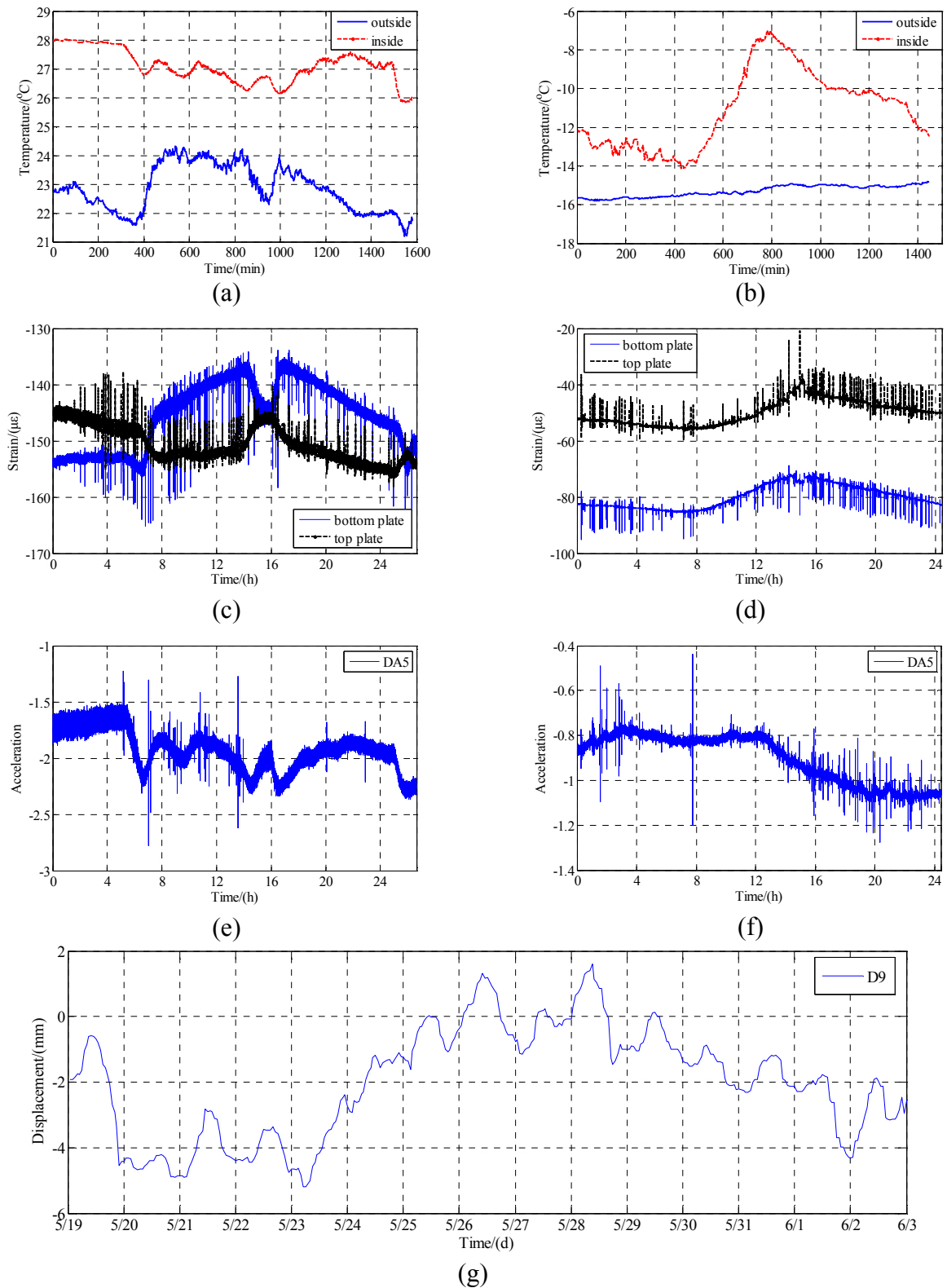

Fig. 5 A part of monitoring data. (a, b) one day temperature variation of outside and inside the box-girder (Jul. 21 2012 and Jan. 21 2013); (c, d) one day strain variation of bottom and top plates of section 5 (Jul. 21 2012 and Jan. 21 2013); (e, f) one day acceleration variation of section 5 (July 21 2012 and Jan. 21 2013); (g) continuous monitoring displacements of section 6 (from May 19 to Jun. 3 2012).

5 Conclusions

The continuous monitoring system on the Fu Sui Bridge consists of 12 hydrostatic leveling sensors to monitor the mid-span displacement, 24 strain sensors to monitor the section strain, 24 temperature sensors to monitor the inside and outside box-girder temperature and 4 accelerometers to monitor ambient vibration. A 6 kilometers optical cable is used to transfer the measurement data and commands between the sensors in the bridge and demodulation devices and computers in the Bridge Management Station. People also can use the Internet to log in the BMS computers to look up the records and change the system index within authorization. The system will continue to provide data for the research of the static and dynamic long-term performance of PSC continuous bridges.

A part of monitoring data is presented in this paper. From the comparison of data between summer and winter, the principal conclusions are as follow: (1) the temperature inside the girder is hardly to change all the whole day in winter; (2) the strain and acceleration data are verified that concrete girder in summer fluctuates more strongly than in winter; (3) vibration amplitude of mid span in winter is much lower than in summer; (4) the displacement of mid span is in periodical fluctuation coincident with the day and night shift.

Acknowledgments

This work was funded by the Key Program of Department of Transportation of Heilongjiang Province whose support is gratefully acknowledged. The authors wish to thank the Construction Headquarters of Fu Sui Bridge for the contribution of the system construction.

References

- [1] M. Mousumi, K.G. Tarun, K.C Ashim, et al. Fiber Bragg Gratings in Structural Health Monitoring-Present Status and Applications, *Sensors and Actuators A: Physical*, 147(1) (2008) 150-164.
- [2] THT Chan, L. Yu, H. Tam, et al, Fiber Bragg Grating Sensors for Structural Health Monitoring of Tsing Ma bridge: Background and Experimental Observation, *Eng Struct*, 28(5) (2006) 648-59.
- [3] M.S. Cheung, G.S. Tadros, T. Brown, et al, Field Monitoring and Research on Performance of the Confederation Bridge, *Can. J. Civ. Eng*, 24 (1997) 951-962.
- [4] C.G. Hugo, P.J. Fanning, M.Q. Feng, et al, Testing and Long-term Monitoring of a Curved Concrete Box Girder Bridge, *Eng Struct*, 33 (10) (2011) 2861-2869.
- [5] X. Wang, M.L. Wang, Y. Zhao, et al, Smart Health Monitoring System for a Prestressed Concrete Bridge, *SPIE 5391: Smart Structures and Materials 2004: Sensors and Smart Structures Technologies for Civil, Mechanical, and Aerospace Systems*, Bellingham, 2004.
- [6] O. Huth, G. Feltrin, J. Maeck, et al, Damage Identification Using Modal Data: Experiences on a Prestressed Concrete Bridge, *J. Struct. Eng.*, 131 (2005) 1898-1910.
- [7] J. Suzuki, Y. Ohba, Y. Uchikawa, et al, Monitoring Temperatures on a Real Box-Girder Bridge and Energy Budget Analysis for Basic Information on Bridge Cooling and Surface Freezing, *J. Bridge Eng.*, 12 (2007) 45-52.
- [8] A. Cury, C. Cremona, J. Dumoulin, Long-term Monitoring of a PSC Box Girder Bridge: Operational Modal Analysis, Data Normalization and Structural Modification Assessment, *Mech. Syst. Signal Process.*, 33 (2012) 13-37.
- [9] P. Moser, B. Moaveni, Design and Deployment of a Continuous Monitoring System for the Dowling Hall Footbridge, *Exp. Tech.*, 37 (2013) 15-26.
- [10] S. Hoon, D. Mark, E.G. Straser, et al, An Experiment Study of Temperature Effect on Modal Parameters of the Alamosa Canyon Bridge, *Earthquake Engng. Struct. Dyn.*, 28 (1999) 879-897.
- [11] J.C. Phillip, R.F. Charles, W.D. Scott, et al, Environmental Variability of Modal Properties, *Exp. Tech.*, 23(6) (1999) 45-48.

-
- [12] X. He, M. Fraser, J.P. Conte, et al, Investigation of Environmental Effects on Identified Modal Parameters of the Voigt Bridge, 18th Engineering Mechanics Division Conference, Blacksburg, 2007.
- [13] O.L. Burdet, Experience in the Long-term Monitoring of Bridges, 3rd fib International Congress, Washington D.C., 2010.
- [14] M. Jakobs, C. Kummerer, V. Marchionni, The Application of a Hydrostatic Levelling System under Extreme Temperature Conditions for the Control of a Protective Measure for Tunnelling under a Railway Bridge in Italy, Conference Messen in Geotechnik, Braunschweig, 2006.
- [15] E. Meier, H. Ingensand, A Multipoint Hydrostatic System for Permanent Deformation Monitoring, International Federation of Surveyors, Brighton, 1998.
- [16] G. Meltz, W.W. Morey, W.H. Glenn, Formation of Bragg Grating in Optical Fiber by the Transverse Holographic Method, Opt. Lett. 14(15) (1989) 823-825.