

A NATIONAL GRAVITY STANDARDIZATION NETWORK FOR EGYPT

BY

GOMAA MOHAMED DAWOD

B.sc., Zagazig University, Egypt.
M.sc., Ohio State University, USA.

A Dissertation Submitted To
The Surveying Engineering Department
Shoubra Faculty Of Engineering,
Zagazig University

For
The Degree Of Doctor Of Philosophy in
Surveying Engineering

Supervised by

Prof. Dr. AHMED A. SHAKER
Vice Dean,
Prof., Surveying Department
Shoubra Faculty of Engineering
Zagazig University

Prof. Dr. DALAL S. ALNAGGAR
Director, Survey Research Institute,
National Water Research Center
Ministry of Public Works and
Water Resources

Dr. ABDALLA A. SAAD
Lecturer, Surveying Department
Shoubra Faculty of Engineering
Zagazig University

1998

To My Kids: Mostafa and Mohamed

بسم الله الرحمن الرحيم

الحمد لله الذي هدانا لهذا وما كنا لنهتدي لولا أن هدانا الله

صدق الله العظيم

ABSTRACT

Gravity control networks are required to support several applications, on a national and international scales, basically in two major domains of geosciences: geodesy and geophysics. Local gravity field representations are essential for establishing geodetic control networks in geodetic and engineering surveys. Accordingly, a recent and accurate gravity framework for Egypt has been established through the Egyptian National Gravity Standardization Network 1997 (ENGSN97). With a national homogeneous distribution and the utilization of precise instrumentation, the ENGSN97 serves as the accurate national gravity datum for Egypt. This research study focuses on all the procedures of data acquisition, processing, adjustment, and analyses of the ENGSN97 network. The present dissertation investigates also, the influencing factors affecting the quality and reliability of developing a final precise geoid solution for Egypt that, is based upon the combination of the available gravity and GPS-derived geoid undulations in Egypt.

Several gravity processing models have been developed in the form of observation equations, for gravimeters readings, as a function of the involved unknown parameters, for each case of observation that can be encountered in practice, when establishing or densifying a first-order gravity network. Those developed processing models have been utilized, and hence, several efficient computer programs have been developed to process, adjust, and analyze the ENGSN97 gravity network.

The developed programs have been run several times, to adjust the entire ENGSN97 gravity network. Of course, there are several items or criteria, associated with the adjustment of such entire network. These items depend upon the way of treating the gravimeter drift function; the way of treating the five absolute gravity stations included in the network; the way of treating the gravimeter reading observations for the two different LaCoste and Romberge used G and D models; and the way of treating the different involved observation loops in the network according to the length and the time span of observations for each loop. All these items are investigated, one at a time, in order to end up with the best optimized solution for the ENGSN97 network, in which all significant influencing factors have been taken into account . Finally, for the best solution, any existing outliers in the observations, are flagged based on a statistical test, and are removed one at a

time, until the best solution is completely filtered out, which gives the final best estimates for the point gravity values of the ENGSN97 network, along with their accuracy estimates.

Concerning the estimated gravity values at the network 150 stations, the obtained results indicate that the minimum adjusted gravity value was 978679.776 mGal while the maximum adjusted gravity value was 979504.981 mGal, with an average value of 979126.005 mGal. As an indication of the precision of the ENGSN97 network, the standard deviations of the adjusted gravity values range from 0.002 mGal to 0.048 mGal, with an average value of 0.021 mGal.

The free-air and Bouguer gravity anomaly maps for Egypt, have been updated based on utilizing all the available gravity data. The free-air gravity anomaly ranges from -122.42 mGal to 128.65 mGal with an average value of -3.21 mGal and RMS equals 28.55 mGal. The Bouguer gravity anomaly ranges from -130.97 mGal to 81.76 mGal with an average value of -21.77 mGal and RMS equals 28.38 mGal.

The final developed combined gravity/GPS geoid solution for Egypt, SRI-GEOID98, has geoid undulations values ranging from 7.22 m to 22.55 m with the mean of 15.31 m and RMS equals 3.10. For the meridian component of the deflection of the vertical, the minimum and maximum values have found to be -23.55" and 24.73" with the average value of -1.11" and RMS equals 4.35". The prime vertical component of the deflection of the vertical ranging from -36.16" to 26.26" with an average value of 1.02" and RMS equals 4.57". The developed SRI-GEOIF98 geoid model is compared with pure GPS-determined undulations, over some GPS check points, and the differences between those undulations and the corresponding values from the developed geoid, are found to be range from a minimum of -1.69 m to a maximum of -0.48 m with an average of -0.41 and RMS equals 0.79. It has been found also that, the developed SRI-GEOID98 geoid solution gives least RMS, when compared with some previously-determined local geoids in Egypt. Therefore, the SRI-GEOID98 geoid model can be considered as the most precise geoid model for Egypt based on the combination between the available most accurate gravity and GPS positioning information.

ACKNOWLEDGEMENTS

Praise be to Allah Almighty. I am extremely grateful to my advisor Prof. Dr. Ahmed A. Shaker, professor of geodesy, Shoubra Faculty of Engineering, Zagazig university, for his continuous guidance, helping me in programming, and fruitful discussions throughout this research work. His advice, constructive criticism and patience have all been greatly appreciated. I wish to express my sincere appreciation to my advisor Prof. Dr. Dalal S. Alnaggar, director of the Survey Research Institute, for suggesting this topic, continuous encouragement, and unlimited guidance. Special thanks go to Dr. Abdalla A. Saad, lecturer of geodesy, Shoubra Faculty of Engineering, Zagazig university, for his truthful support and constructive criticism.

I would like to express my deepest gratitude to Prof. Dr. Mohamed M. Nassar, professor of geodesy, Faculty of Engineering, Ain Shames university, for his stimulating discussions, straightforward clarification, and invaluable assistance.

My acknowledgments are also given to many scientists outside Egypt who helped me a lot through providing data, computation programs, geopotential models, and their fruitful discussions. I remarkably acknowledge the assistance of:

Prof. Dr. Hans Sünkel and Mr. Roland Pail, Technical University, Graz, Austria,

Dr. Dennis Milbert and Dr. Dru Smith, The National Geodetic Survey, USA,

Dr. Howard Small and Mr. David Stizza, The National Imagery and Mapping Agency, USA, and

Dr. Gerd Boedecker, The Bavarian Academy of Sciences, Germany,

Grateful acknowledgment and thankfulness are expressed to Prof. Dr. Mona M. El-Kady, chairman of the National Water Research Center, who switched my career to the academic profession through motivation and encouragement. Special thanks go to the Egyptian Survey Authority for providing the data of the Egyptian High-Accuracy Reference GPS Network. Also, I would like to express my sincere appreciation to Dr. Ali El-Sagheer, lecturer of geodesy, Shoubra Faculty of Engineering, Zagazig university, for kindly providing his developed digital elevation model for Egypt.

Unlimited appreciation, honest gratefulness, and deep thanks are granted to my wife, Eng. Hoda Faisal, for her continuous encouragement, assistance, patience, and powerful arguments.

TABLE OF CONTENTS

	Page
Abstract	I
Acknowledgment	III
Table of Contents	IV
List of Figures	VIII
List of Tables	X
1. Introduction	1
1.1 Historical background about gravity measurements in Egypt	2
1.1.1 Earliest gravity measurements in Egypt	2
1.1.2 The International Gravity Standardization Network 1971 (IGSN-71)	3
1.1.3 The National Gravity Standard Base Network 1977 (NGSBN-77)	6
1.1.4 Egyptian Survey Authority's gravity measurements	7
1.1.5 Other gravity measurements in Egypt	7
1.2 Motivations behind the present research	10
1.3 Objectives of dissertation	12
1.4 Scope of presentation	13
2 Fundamentals of gravimetry	16
2.1 Types of gravity surveys	19
2.2 Gravity networks	19
2.3 Gravity instruments	22
2.3.1 Absolute gravity meters	22
2.3.2 Relative gravity meters	23
2.4 Gravity observation techniques	31
2.5 Gravity processing models for some selected networks	32
2.5.1 The IGSN-71 network	38
2.5.2 The NGSBN-77 network	34
2.5.3 The Jordanian Gravity Standard Network 1990 (JGSN90)	39
2.6 Gravimetric reductions of terrain geodetic measurements	40
2.7 Gravity anomalies	44

TABLE OF CONTENTS (cont.)

	Page
2.7.1 The free-air gravity anomaly	46
2.7.2 The Bouguer gravity anomaly	47
2.7.3 The isostatic gravity anomaly	50
2.7.4 A discussion of different types of gravity anomalies	51
3. The Establishment of the Egyptian National Gravity Standardization Net 1997 (ENGSN97)	53
3.1 Design of the ENGSN97 network	54
3.2 Monumentation	56
3.3 Absolute gravity measurements	57
3.4 Relative gravity measurements	60
3.5 GPS measurements	69
3.6 Precise levelling measurements	71
4. Development of appropriate models for processing and adjustment of the ENGSN97 gravity data	74
4.1 Analysis of previously used gravity processing networks	75
4.2 Criteria of the presently developed gravity processing models	76
4.3 The developed observation equation gravity processing models	78
4.3.1 Processing model for a single loop observed by a single gravimeter	79
4.3.2 Processing model for a single loop observed by several gravimeters	82
4.3.3 Processing model for several virtual gravimeters (with occurred time breaks) in a single loop	83
4.3.4 General processing model for several loops observed by several gravimeters	84
4.3.5 A model for absolute gravity measurements	85
4.4 The least-squares adjustment of the developed observation equation models	86
4-5 Detection of outliers	95

TABLE OF CONTENTS (cont.)

	page
5. Data processing and analysis of results of the ENGSN97 network	100
5.1 The ENGSN97 gravity data	101
5.2 The developed computer programs for processing the ENGSN97 gravity data	104
5.2.1 Primary analysis of each loop using one gravimeter at a time	104
5.2.2 Analysis of each loop using different gravimeters combined together	109
5.2.3 The processing of the entire ENGSN97 gravity network	111
5.2.4 Assessment of the developed program (GNPA)	113
5.3 Performed different solutions to arrive at the best optimum results for the ENGSN97 network	114
5.3.1 First Solution: Introducing one absolute gravity station as completely fixed in the adjustment of the network	117
5.3.2 Second Solution: Introducing appropriate weights for the absolute gravity stations	119
5.3.3 Third Solution: Investigating the non-linear drift against linear drift functions	122
5.3.4 Fourth Solution: Introducing different weights for different gravimeters used	123
5.3.5 Fifth Solution: Introducing different weights for loops according to their observation times	124
5.3.6 Sixth Solution: After satisfying all significant affecting criteria	125
5.3.7 Final Solution: After filtering out all outlier observations	127
5.4 Gravity Changes at some locations in Egypt	129
5.5 Essential characteristics about the final solution of the ENGSN97 network	130
6. Developing geoid models for Egypt based on the available gravity and GPS-based positioning data	140
6-1 Adopted geoid determination techniques	141
6.1.1 Gravimetric geoid computations	143
6.1.2 Geometric satellite geoid computations	150
6.2 Adopted geoid determination processing technique	153

TABLE OF CONTENTS (cont.)

	Page
6.3 Developing high-precision geoids for Egypt	155
6.3.1 Developing gravimetric geoids	157
6.3.1.1 Geoid solution 1 (EGY-G1): A gravimetric geoid using ENGSN97 data and a global DEM	158
6.3.1.2 Geoid solution 2 (EGY-G2): A gravimetric geoid using all available gravity data and a global DEM	165
6.3.1.3 Geoid solution 3 (EGY-G3): A gravimetric geoid using all available gravity data and a local DEM	170
6.3.1.4 Geoid solution 4 (EGY-G4): A gravimetric geoid using all available gravity data being corrected for the terrain effect, a local DEM	175
6.3.2 Developing a GPS-based geoid for Egypt (EGY-G5)	181
6.3.2.1 The available GPS-based geoid undulation data sets	181
6.3.2.2 Integration of the available GPS undulation data sets into the same reference system	182
6.3.2.3 The obtained results of the integrated GPS geoid (EGY-G5)	188
6.3.3 Developing combined gravimetric/GPS geoids for Egypt	191
6.4 Essential characteristics of the final geoid model for Egypt SRI-GEOID98	196
6.5 Performance of SRI-GEOID98 geoid model over the purely GPS-determined undulations	204
6.6 A comparison between SRI-GEOI98 and some previously- determined local geoids in Egypt	206
7. Summary, Conclusions, and Recommendations	209
List of references	220

List of figures

Figure	page
1-1 The IGSN-71 gravity stations in Egypt	5
1-2 The NGSBN-77 Network	8
1-3 The ESA gravity measurements	9
2-1 The FG5 absolute gravimeter	24
2-2 The astatization principle	27
2-3 LaCoste and Romberge (LCR) gravimeter	30
2-4 The gravity observation schemes	33
2-5 Orthometric and ellipsoidal heights	42
2-6 The Bouguer plate and terrain correction	49
3-1 The Egyptian National Gravity Standardization Network 1997	58
3-2 The monumentation of the ENGSN97 Network	59
3-3 The gravity field data recording sheet of the ENGSN97 Network	63
3-4 An ENGSN97 gravity loop	64
3-5 The description card of the ENGSN97 stations	66
3-6 Gravimeters drift computations	68
3-7 An example of GPS sessions in an ENGSN97 loop	70
3-8 An example of the precise levelling in an ENGSN97 loop	73
5-1 The ENGSN97 gravity loops	107
5-2 The ENGSN97 gravity loop number 1	108
5-3 The flow chart of the GNPA developed program	115
5-4 Frequency distribution of the residuals of the gravimeter readings over the ENGSN97 network	134
5-5 Distribution of the standard deviations of the adjusted gravity value for the 150 gravity stations of the ENGSN97 network	135
5-6 Free-Air gravity anomalies Obtained from ENGSN97 data	138
5-7 Bouguer gravity anomalies obtained from ENGSN97 data	139
6-1 Stokes' function	146
6-2 Stokes' sphere	146
6-3 Actual and condensed topography in planar approximation	147
6-4 Contributions of different data to geoid determination	149
6-5 Geometric satellite geoid determination	152
6-6 The remove-compute-restore FFT processing strategy	156
6-7 The TOPO5 global Digital Elevation Model (DEM)	161

List of figures (cont.)

Figure	page
6-8 Free-air anomalies of OSU91A model	162
6-9 The EGY-G1 developed geoid solution (using ENGSN97 gravity data and a global DEM)	163
6-10 Differences between the developed geoid solution EGY-G1 and the OSU91A global geopotential models	164
6-11 The data used in developing EGY-G2 geoid solution	167
6-12 The EGY-G2 developed geoid solution (using all available gravity data and a global DEM)	168
6-13 The differences between EGY-G1 and EGY-G2 geoid solutions	169
6-14 Local DEM model based on the collected elevation data until 1955	172
6-15 The EGY-G3 developed geoid solution (using all available gravity data and a local DEM of 1995)	173
6-16 Differences between EGY-G2 and EGY-G3 geoid solutions	174
6-17 The EGY-G4 developed geoid solution (using all available terrain-corrected gravity data and a local DEM of 1995)	179
6-18 Differences between EGY-G3 and EGY-G4 developed geoid solutions	180
6-19 The available GPS stations	183
6-20 The GPS-based developed geoid solution EGY-G5	189
6-21 Differences between the developed GPS geoid EGY-G5 and the gravimetric geoid EGY-G4	190
6-22 The developed combined gravity/GPS EGY-G6 geoid solution	194
6-23 Differences between the EGY-G6 and EGY-G5 developed geoid solutions	195
6-24 Obtained updated free-air gravity anomaly map for Egypt	199
6-25 Obtained updated Bouguer gravity anomaly map for Egypt	200
6-26 Resulted meridian deflection of the vertical map for Egypt	201
6-27 Resulted prime-vertical deflection of the vertical map for Egypt	202
6-28 Location of the GPS check points used	207

List of tables

Table	page
1-1 The IGSN-71 gravity stations in Egypt	4
2-1 Gravimetric applications in applied sciences	17
2-2 The error budget for LaCoste Romberge relative gravimeters	29
2-3 Individual adjustments of the IGSN-71 network	35
5-1 The ENGSN97 input data	102
5-2 The processing results of loop 1	108
5-3 Statistics of the differences between the estimated and known gravity values for the four absolute gravity stations when treated as completely unknown	119
5-4 Statistics of the differences between the estimated and known gravity values at the five absolute gravity stations when treated as quasi-observables or weighted parameters	121
5-5 Criteria employed in the developed different solutions	126
5-6 Changes of gravity values at some locations in Egypt	129
5-7 Essential information for the final adjustment of the ENGSN97network	133
6-1 Statistics of used anomaly data from both the ENGSN97 network and the OSU91A geopotential model	160
6-2 Statistics of EGY-G1 and OSU91A geoids	160
6-3 Statistics of the differences between EGY-G1 and EGY-G2 developed geoid solutions	166
6-4 Statistics of the differences between EGY-G2 and EGY-G3 developed geoid solutions, as expressing the effect of both global and local DEM models	175
6-5 Statistics of terrain corrections	176
6-6 Statistics of the differences between EGY-G3 and EGY-G4 developed geoid solutions, as expressing the effect of applying the terrain correction to the observed gravity values on the resulted geoid	178
6-7 Statistics of undulation differences between the FINNMAP results and the corresponding HARN reference values for the five investigated transformation model	187
6-8 Statistics of the differences between the GPS geoid EGY-G5 and the gravimetric geoid EGY-G4	189

List of tables (cont.)

Table	page
6-9 Statistics of undulation differences between the gravimetric undulations and the corresponding GPS reference undulations for the five investigated transformation models	192
6-10 Statistics of the resulted undulation from the combined gravity/GPS developed geoid solution EGY-G6	193
6-11 Statistics of undulation differences between the pure GPS geoid EGY-G5 and the combined gravity/GPS geoid EGY-G6	195
6-12 Summary of the used data for the different developed six geoid solutions for Egypt	197
6-13 Statistics of the SRI-GEOID98 anomalous gravity field parameters	204
6-14 Statistics of the previously and recently computed local geoid solutions in Egypt	208

Chapter 1

Introduction

Gravity data find multiple demands basically in two major fields of geosciences: geodesy and geophysics. The principle task of geodesy is the determination of the Earth's surface that is extended to the determination of the exterior gravity field. The gravity field has to be modeled in order to derive geometrically defined quantities from the observations. Local gravity field representations are required for establishing geodetic control networks in geodetic and engineering surveys. With the rapid growth of the use of the satellite-based Global Positioning System (GPS), high resolution gravity field data are needed to transform the ellipsoidal heights into orthometric heights. In geophysics, gravity data are used in a wide range of applications such as exploration of mineral and underground water resources, monitoring crustal movements, and the study of the orbits of natural and artificial celestial bodies.

Gravity control networks are essential to support several applications on a national and international scales. The Potsdam gravity system provides an example of an international gravity datum from 1909 to 1971. In Egypt, the National Gravity Standard Base Net (NGSBN-77) afforded the gravity framework in the second half of the twentieth century. In addition, the Egyptian Survey Authority (ESA) usually is carrying out gravity measurements, for some specific applications, especially for correcting precise levelling observations. However, all such gravity measurements, can not satisfy the modern precise applications in Egypt. Consequently, the establishment of a precise new national gravity base network becomes an essential and urgent task for the geodetic community in Egypt, and this is actually the main point of our interest in the current investigation.

In this chapter, a historical background encompassing gravity measurements in Egypt, on both international and national levels, will be given first. Then, the basic motivations behind undertaking the present research, will be outlined. The objectives of the present thesis are explicitly defined and enumerated. Finally, the scope of presentation of the materials contained in this thesis, will be briefly outlined.

1.1 Historical background about gravity measurements in Egypt

The gravimetric observations that have been carried out in Egypt have been collected, reviewed, and assessed. This section gives a historical background of the gravimetric activities in Egypt.

1.1.1 Earliest gravity measurements in Egypt

The earliest absolute gravity observations in Egypt have been carried out in 1908 at Helwan observatory using the Stuckrath pendulum apparatus by a British expert. This station was considered as the fundamental gravity station in Egypt with a gravity value of 979.295 Gal [Cole, 1944]. Other seven gravity stations in Egypt and Sudan have been observed in that year. These stations have been tied to Kew, London. The Egyptian Survey Authority, formally the Survey of Egypt, has started its first gravity survey in 1927 using a pendulum apparatus [ibid].

Starting from 1922, some foreign oil companies have carried out gravimetric survey as a geophysical exploration tool, mainly in the Gulf of Suez. From 1922 to 1938, more absolute gravity measurements have been carried out at Ras Gharib, Helwan, Suez, Shadwan, Rahmi, Wadi El-Natron, and Amria.

From 1938 to 1950, more precise gravimeters have been used in gravimetric surveys. Within an international gravity program, twenty-one stations have been established in Egypt in 1950-1951 and tied to the Potsdam gravity reference system [Kamel and Nakhla, 1985].

1.1.2 The International Gravity Standardization Network 1971 (IGSN-71)

By the early 1950's the international geodetic community decided that the Potsdam gravity datum, with its estimated 3 mGal accuracy, does not meet the recent accuracy requirements for geodetic applications. In 1954, the International Association of Geodesy (IAG) formed a special study group for the establishment of a new gravity datum. A network of 34 stations was chosen in 1956 to be known as the first-order world gravity network. During the next 8 or 9 years, relative gravity measurements were carried out on a world-wide basis.

In August 1971, the International Gravity Standardization Net (IGSN-71) was introduced as the new global gravity reference system. The network contains 473 primary stations (eight of them are absolute stations) and 139816 excenter bases. The eighty six instruments utilized in the net are divided into three main categories: three absolute devices; six Pendulum instruments; and five gravimeters' types. The absolute data provided the datum and contributed to scale, the pendulum data contributed to scale and the gravimeter data gave the basic structure of the net. Approximately 25,000 observations are included in processing the IGSN-71. The standard errors for the net's gravity values are less than 0.1 mGal [Morelli et al., 1974].

As a part of the IGSN-71 activities, eleven gravity stations have been measured in Egypt (Fig 1.1) with standard deviations range from 0.024 to 0.035 mGal. Table 1-1 presents the gravity values of these stations.

Table 1-1
IGSN-71 gravity stations in Egypt

Station Number	Location	Gravity Value (mGal)	Standard Error (mGal)
10591 B	Helwan Obs.	979276.76	0.025
10591 C	Helwan Obs.	979279.44	0.027
10591 L	Cairo Airport	979301.25	0.024
10591 M	Cairo Airport	979300.34	0.024
10591 N	Cairo Airport	979300.33	0.026
10542 J	Aswan City	978854.21	0.035
10542 K	Aswan Airport	978823.15	0.032
10552 J	Luxor City	978960.04	0.031
10552 K	Luxor Airport	978948.70	0.029
10511 J	Wadi Halfa	978708.65	0.029
10511 K	Wadi Halfa	978702.81	0.026

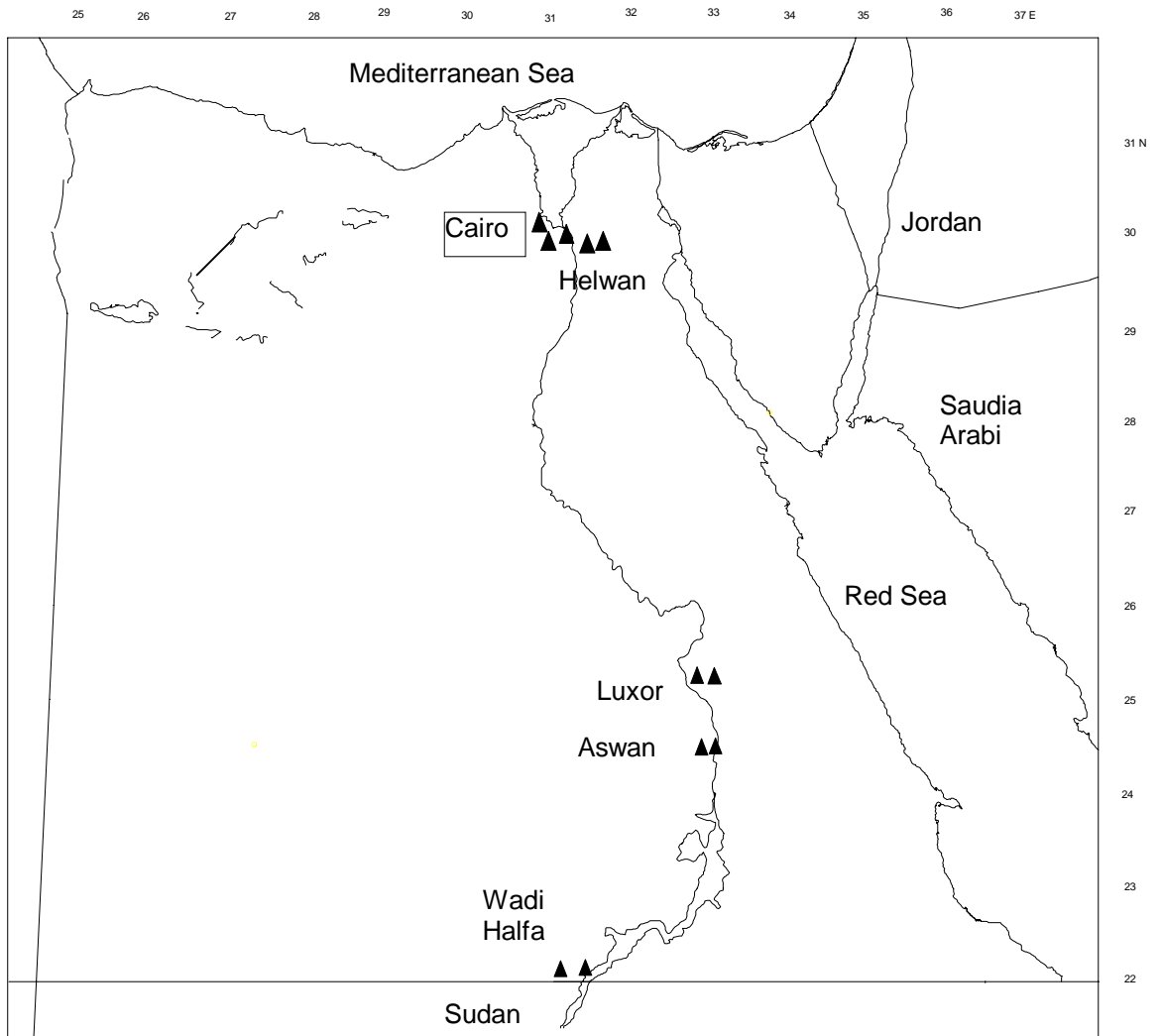

Figure 1-1
IGSN-71 Gravity Stations in Egypt

1.1.3 The National Gravity Standard Base Network 1977 (NGSBN-77)

A ten-year project (1974 - 1984) for compilation of gravity maps of Egypt has resulted in the National Gravity Standard Base Net (NGSBN-77). The objectives of the project were:

- * To compile and review the available gravity surveys conducted in Egypt.
- * To conduct new gravity measurements for the unsurveyed parts and to tie these measurements with previous surveys.
- * To establish a national gravity network to be tied to the IGSN-71 net, and
- * To prepare a consistent and homogenous gravity map of Egypt.

The project was executed and supervised by the General Petroleum Company (GPC) under the auspices of the Egyptian Academy of Sciences and Technology. The NGSBN-77 consists of 66 stations (Figure 1-2) and has tied to IGSN-71 stations located at Cairo International airport, Helwan observatory, Luxor, Aswan, and Port Said (Figure 1-1). The network's 624 gravity observations have been carried out using two Worden gravimeters which have a sensitivity of 0.01 scale units [Kamel and Nakhla, 1985]. Most of the network's stations have been tied to the triangulation networks to determine their horizontal coordinates (latitude and longitude) and their vertical position (elevations above MSL) by means of tachometry. The coordinates of about twenty stations located at inaccessible areas, in the western desert and Sinai, were interpolated from topographic maps. Stations located in remote areas in the western desert were conducted using aircrafts. The mean square errors for the observations range between 0.04 - 0.47 mGal. A final adjustment of the data based on the Pogov's method of successive iteration yields standard deviations of the gravity values ranging between 0.02 - 0.13 mGal [Kamel and Nakhla, 1985].

1.1.4 The Egyptian Survey Authority (ESA) gravity measurements

The Egyptian Survey Authority (ESA) has carried out some gravimetric surveys along the first order leveling lines concentrated in the Northern part of Egypt (Fig. 1-3) using Worden gravimeters. The main gravity loops observed by ESA (during the 70's) are:

- * A loop from Giza to the mid of the Cairo-Alexandria desert road consists of 15 gravity observations at bench marks.
- * A loop from Giza - Korimate - Ras Gharib - Shikh Fadl - Giza extending about 760 km and contains 72 gravity stations.
- * A loop from Shikh Fadl - Ras Ghareb - Qena - Shikh Fadl contains 112 gravity points over 1046 km total distances.

ESA is usually conducting several gravity missions needed to compute the required corrections for the first-order levelling routes.

1.1.5 Other gravity measurements in Egypt

Several other organizations in Egypt conduct gravity missions for special purposes. The National Research Institute of Astronomy and Geophysics (NRIAG), for example, has observed several small gravity networks as a part of complex geodetic networks serve for the detection of crustal deformation. Most of these loops are concentrated in the active crustal movement zone of Aswan lake [Groten and Tealeb, 1995].

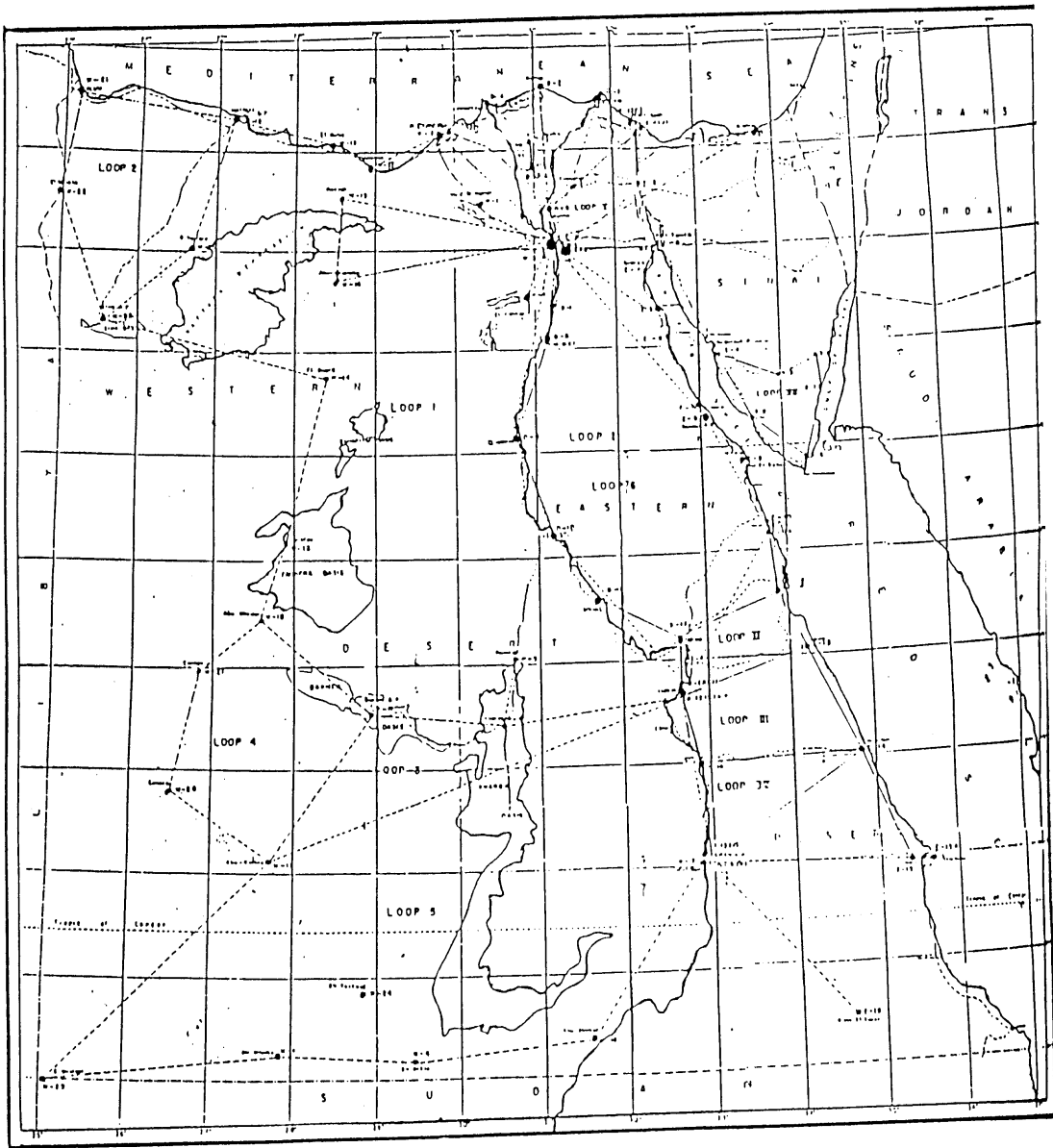

Fig 1-2

The NGSBN-77 Gravity Network

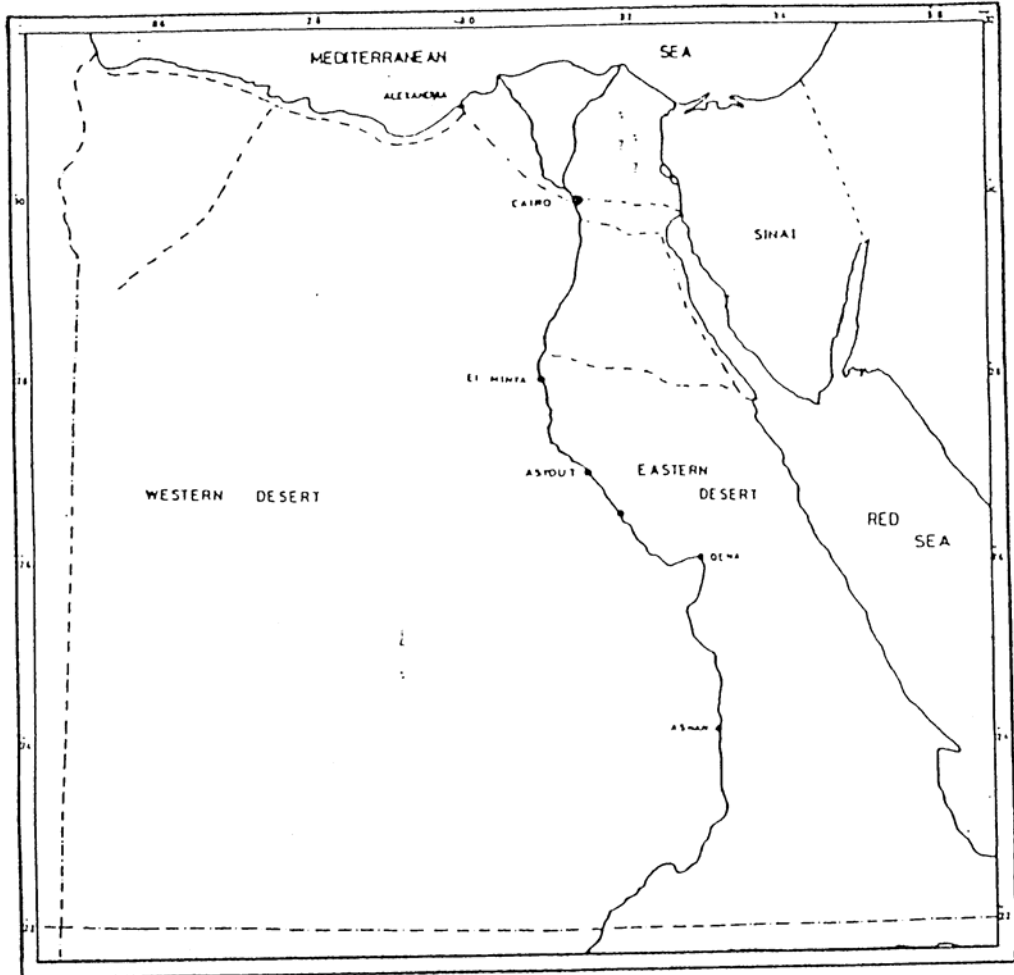

Fig 1-3

ESA Gravity Measurements

1.2 Motivations behind the present investigation

Based on the above discussions, it can be seen that, precise gravity values at well-distributed locations of the Egyptian territory, has become an urgent geodetic task for Egypt. This is the case, since all modern precise geodetic and geophysical applications, in Egypt, require the highest possible accurate gravity control network. However, as presented in the previous section, some of the interested organizations, like ESA and NRIAG, perform gravity observations for very limited applications, which of course, are done within small areas of interest, and are not covering the entire Egyptian territory. This is the case, for most of the oil and mineral exploration companies, even for those, the high accuracy of the gravity values is not an essential requirement. In addition, It could be seen from Figure (1-2) that the NGSBN-77 did not possess a homogenous distribution over the Egyptian territories especially in the south-west section of the western desert and Sinai. Beside, since such national network has aged more than fifteen years, and due to lack of its maintenance and updating, it is expected that most of its 66 stations could be destroyed, and consequently will be useless as gravity control.

The above mention reasons constitute the basic motivations behind undertaking our research contained herein. This is, again, the establishment of a precise national gravity standardization network, having as many control stations as possible, and very well-distributed over the Egyptian territory, which constitute the basic gravity control framework for any future extension or densification, to cope with the urgent Egyptian geodetic and geophysical needs.

Therefore, in 1994, a project for re-calibration and updating an Egyptian national gravity network was initiated. Such network will be named as the

Egyptian National Gravity Standardization Network of 1997 (ENGSN97). The Survey Research Institute (SRI) of the National Water Research Center (NWRC) is the executive organization of the ENGSN97 network with the cooperation of the General Petroleum Company (GPC) under the auspices of the Egyptian Academy of Sciences and Technology. With a national homogeneous distribution and the utilization of precise instrumentation, the ENGSN97 network serves as the precise national gravity datum for Egypt. The ENGSN97 consists of 150 stations with a homogeneous distribution covering the Egyptian territories. LaCoste and Romberge gravimeters are used to measure the relative gravity of these stations. The satellite-based Global Positioning System (GPS) advanced technology is applied to determine the three-dimensional coordinates of the stations precisely. The orthometric heights of the stations are obtained using precise leveling techniques. By this way, each gravity station of the EGSN-97, will precisely have three-dimensional geodetic position (latitude, longitude, and geodetic height) from GPS data, as well as vertical position implemented by the orthometric height from precise levelling. Such complete geodetic information about each gravity station, will certainly provide a very useful data for a multitude of precise applications in Egypt, for instance, the geoid computations and its comparison with other Egyptian geoids, determined from different sources of data and techniques. Such an application will be presented and analyzed at the end of this thesis. Since the ENGSN97 is the main core of this dissertation, it will be documented in details in this research.

1.3 Objectives of the dissertation

Based on the above discussions, and in order to achieve the highest possible accuracy for the ENGSN97 network, some interested points have been defined as the objectives of the current investigation. This research study focuses on all the procedures of data acquisition, processing, adjustment, and analyses of the ENGSN97 network. The main objectives of this dissertation are:

- (1) The study and analysis of some similar gravity networks on both national and international scales.
- (2) The study of relative gravimeters' performance especially the recent models of LaCoste and Romberge instruments used in the ENGSN97 network.
- (3) The development of processing and adjustment models that are capable of treating all types of observations schemes applied in the ENGSN97 network.
- (4) The development of computer programs that, utilize the developed processing models in an effective manner on a PC configuration.
- (5) The utilization of statistical tests to increase the reliability of the observations in order to come up with precise and unique adjusted values of gravity for the ENGSN97 stations.
- (6) The development of recent combined geoid models for Egypt including the values of geoid undulations and the two components of the deflection of the vertical through the integration of gravimetric and GPS data, to be considered as one important and direct geodetic application for the established precise ENGSN97 gravity network, just as an example.

1.4 Scope of presentation

In order to achieve the above mentioned objectives, the materials in this dissertation is presented in seven chapters.

Chapter two summarizes the basic subjects related to gravimetry and gravity networks and reviews some of the gravity networks on a national, regional, and international levels. Firstly, the types of gravity surveys and the different gravity networks classifications will be presented. Then, gravity instruments, for both absolute and relative gravity measurements, as well as the different techniques for gravity observations, will be given. Afterward, the different methods for gravity data processing, will be handled. Then, the gravimetric reductions of geodetic terrestrial measurements will be discussed. Finally, the different types of gravity reductions and anomalies will be provided.

In chapter three, the basic items connected with design, and field measurements of the ENGSN97 network will be discussed. Firstly, the design and monumentation of the network's stations will be given. Then, the gravity measurements, including both relative and absolute observations, will be introduced. Finally, the station positioning measurements, using both the Global Positioning System (GPS) technology and the precise levelling technique, will be outlined.

Chapter four, first presents the analysis of gravity processing models, used previously in adjusting some selected national and international gravity networks. Then, the stipulated criteria for the new developed model, comprising all different cases of observational schemes, will be presented, according to which the sought processing model is developed. The least-squares adjustment

of the overdetermined developed mathematical model, in the form of observation equations, until a final solution for the involved unknown parameters is obtained, along with their accuracy estimates, will be outlined. Finally, the adopted approach for detecting outlier gravimeter readings, will be discussed.

Chapter five is devoted to the data processing of the ENGSN97 network, including the highlight of the developed computer programs, needed for all involved computations, as well as performing different solutions, for investigating all affecting factors on the final results, one at a time. The collected data for the ENGSN97 gravity network, according to its adopted configurations, techniques of observations, and available types of gravimeters, will be given first. Then, the developed computer software, for processing single or multi loops, observed with one or more gravimeters, with or without time breaks during observations, until the recovery of the entire network, will be outlined. In addition, six different solutions of the entire network, which ended up with the best solution taken all influence factors into account. The final solution of the ENGSN97 network will be achieved, after removing all existing outlier gravimeter readings from the last solution number six. For this final solution, the gravity variations at some locations over the Egyptian territory, over a period of more than twenty years, will be investigated by comparing their gravity values, with the corresponding ones from old international and national gravity networks. Finally, the essential characteristics of the final solution of the ENGSN97 network, as considered to be the best possible optimum solution that can be currently obtained, will be summarized, along with the obtained gravity anomalies maps for Egypt, based on the final results of that best solution.

Chapter six aims to investigate the influence factors affecting the quality and reliability of developing a final precise geoid solution for Egypt that, is based upon the combination of the available gravity and GPS-derived geoid undulations. First, a brief outline of the adopted techniques for geoid determinations, namely the gravimetric geoid computations using the Fast Fourier Technique, and the geometric satellite geoid determination, will be documented first. Then, the remove-compute-restore strategy, as the adopted geoid determination processing techniques in the present research study, will be demonstrated. In addition, the results of developing four gravimetric geoid solutions, a GPS-based geoid solution, and a combined gravity/GPS final geoid solution, will be given in details. The characteristics and statistics of the final recent and accurate combined gravity/GPS geoid solution for Egypt, named here as SRI-GEOID98 geoid, will be given. Finally, a comparison between the final developed geoid model with other geoid solutions for Egypt, as previously developed by other investigators, will be presented.

Chapter seven provides a summary of the dissertation, conclusions, and some recommendations for future researches.

Chapter 2

Fundamentals of gravimetry

Gravimetry is the science of measuring the magnitude of the gravity acceleration and the gravity gradient on or near the surface of the Earth and other celestial bodies. Accordingly, instrumentation, measurements methods, and evaluation techniques are the principal components of gravimetry. Gravimetry has direct implementations in a wide range of sciences such as physics, geophysics, astronomy, geodynamics, and geodesy. Table 2-1 gives some examples of gravimetric applications in applied sciences. Establishment and measuring gravity networks is the core of the gravimetry science.

In geodesy, almost every geodetic measurement depends in a fundamental way on the Earth's gravity field. Since Newton (1642-1727) formulated the law of universal gravitation, great advances have been accomplished in different areas related to the measurements of gravity and the modeling of the Earth's gravity field. Before the introduction of the SI units, the gravity acceleration was expressed in terms of Gals, derived from Galileo, where 1 Gal was defined in the CGS system as an acceleration of 1 centimeter per square second. Following are some relations between the different units frequently used in gravity measurements.

$$1 \text{ Gal} = 1 \text{ cm/s}^2 = 1 \times 10^{-2} \text{ m/s}^2$$

$$1 \text{ Gal} = 1000 \text{ mGal}$$

$$1 \text{ mGal} = 1 \times 10^{-5} \text{ m/s}^2 = 10 \text{ } \mu\text{m/s}^2$$

Table 2-1
Gravimetric Applications in Applied Sciences

Field	Applications of Gravimetry
Geodesy	<p>The gravity field modeling is crucial for deriving geometrically-defined quantities from the geodetic observations.</p> <p>If the distribution of the gravity values on the surface of the Earth is known, the shape of this surface may be determined.</p> <p>The most important reference surface for height measurements, the geoid, is a level surface of the gravity field.</p>
Geodynamics	Temporal gravity changes discovered by repeated gravity observations represent important information of terrestrial mass displacement.
Astronomy	The terrestrial gravity field is required for the orbit computations of natural and artificial celestial bodies.
Physics	Gravity is needed in physical laboratories for the realization of force standards and derived quantities.
Geophysics	Gravimetric data has essential information about the density distribution in the different layers in the upper crust.

The magnitude of the gravity at points on the Earth's surface varies through a range of 5000 mGal, from about 978000 mGal at the equator to 983000 mGal at the poles. The main components of this variation are systematic and can be quantified as: first, an increase in the gravity value with increasing latitude due to the fact that the Earth's surface at the pole is some 22 km nearer to the Earth's center of mass than is the surface at the equator; and second, a decrease in the gravity with increasing height above sea level since the increase in height means an increase in the distance to the Earth's center of mass. In addition to the main systematic variations in the gravity values, there are random variations up to 300 mGal which reflect the irregular nature of the Earth's crust and variations in density of its materials. These random variations make gravity surveys necessary.

This chapter summarizes the basic subjects related to gravimetry and gravity networks and reviews some of the gravity networks on a national, regional, and international levels. Firstly, the types of gravity surveys and the different gravity networks classifications will be presented. Then, gravity instruments, for both absolute and relative gravity measurements, as well as the different techniques for gravity observations, will be given. Afterward, the different methods for gravity data processing, will be handled. Then, the gravimetric reductions of geodetic terrestrial measurements will be discussed. Finally, the different types of gravity reductions and anomalies will be handled.

2.1 Types of gravity surveys

The main task of the gravimetry science is to get a complete knowledge of the Earth's gravity field. Consequently, dense gravity measurements all over the Earth are essential for geodetic and geophysical applications. Therefore, rapid gravity survey procedures are desired, mainly due to economic considerations. The three main categories of gravity surveys are: on land, on sea, and airborne gravimetric surveys.

The ground gravity surveys, use absolute or relative gravity meters, are carried out on the Earth's surface, using cars as a mean of transportation from a terrestrial gravity station to another. Accuracy of 0.002 to 0.040 mGal are achieved in high-precision ground gravimetric surveys. Large areas can be surveyed quickly when gravimeters are installed on moving platforms (ship, helicopter, airplane). Accuracy of 2 mGal are achieved in helicopter operation, and 5 to 10 mGal in airplanes.

In the present study, the land gravity survey technique is employed, since all the ENGSN97 stations are all accessible by ground vehicles.

2.2 Gravity networks

Gravimetric measurements differ with respect to their spatial extension and with respect to station separation and accuracies as defined for a specific project. Gravity networks are established to create global, regional, and local arrays of gravity control points. On a global level, the

Potsdam gravity system was valid from 1909 until 1971 as a global gravity datum. This system was based on the absolute gravity measurement performed around 1900 with reversible pendulum at Potsdam, and was extended worldwide by converting gravity values to this datum. The International Gravity Standardization Network 1971 (IGSN-71) replaced the Potsdam system as a more precise global gravity framework. Besides the international gravity networks, there are some international calibration lines stretching across wide areas so as to cover the widest possible range of gravity values. Their points are usually observed very precisely to establish very precise knowledge of gravity. They are used to calibrate individual gravimeters, i.e., to derive one to one correspondence of scale readings with gravity values.

Regional gravity networks, with station separation of few km to 100 km, are established as national networks mostly in the form of a fundamental gravity network with related densification networks. Such regional networks, should be connected with the latest approved international gravity network, through the absolute gravity stations existing in the country in which the regional gravity network is to be established. In some cases where no absolute gravity stations are available in the country, one should establish some absolute stations, by connecting them to the most nearest stations of the international gravity network, as existing in other neighboring countries. The national (regional) gravity networks are divided into three orders: first, second, and third order. First-order networks consist of the national reference stations and all the absolute points. They are usually located at the airports, and main astronomic and geodetic observatories, so that the access

to them is easy. Second-order gravity networks consist of points established some 10-30 Km apart, which must be connected to the first-order networks. Third-order networks have points closer together although their accuracy is lower, and of course must be connected to the second and first-order stations.

In Egypt, the National Gravity Standard Base Network 1977 (NGSBN-77) provided a national gravity datum of first order, which includes 66 gravity stations. The base gravity station in Egypt is the one located at the Helwan observatory. The General Petroleum Company (GPC) has established several gravity networks of second and third-order accuracy, connected to the first-order network. However, those lower-order accuracy stations are concentrated along the Nile valley, and are clustered in many places. Such networks were established solely for geophysical exploration, where their lower accuracies make them of little geodetic applications.

Local gravity networks, with station separation of a few 0.1 to 10 km, are mostly established for specific geodetic or geophysical purposes. Such local networks are usually established by oil and mineral exploration companies for specific relatively small areas of their interest, in which the location of various mineral deposits and oil basins are performed. Such networks are usually connected to the second and third-order stations of the national gravity networks.

The national gravity network of first order is usually adjusted first, and the obtained results of gravity values at its stations are kept fixed. Then,

the second-order and lower-order densification of the first-order network are adjusted separately and connected to the fixed values of the first-order. However, the entire gravity networks of different orders can be adjusted simultaneously by introducing appropriate weights for each order, for instance, assigning the largest weights to the first-order stations, and so on.

2.3 Gravity instruments

Gravimetric instrumentation is available since the 17th century, and they are divided into two types: absolute and relative gravity meters. Absolute gravimeters depend on measuring the fundamental acceleration quantities length and time. On the other hand, for relative gravity measurements, either time is observed, keeping the length constant, or a counterforce is used to observe length changes, with gravity differences as the final result. The basic concept of both absolute and relative gravity meters, will be presented bellow.

2.3.1 Absolute gravimeters

Absolute gravimeters depend exclusively on the free-fall technique. The simple idea is to measure several distance-time pairs of measurements of a certain mass falling in a vacuum in order to determine the absolute gravity value at a specific location. The first derivative of the distance is the velocity while the second derivative yields the gravity acceleration. Of course, there are many types of absolute gravimeters currently used in practice. However, the specific absolute gravimeter, which was used in

measuring five absolute gravity stations of the ENGSN97 network, that is of special interest in the present research, is the FG5 type. This type is of micro-g Inc., for which some more details will be given below.

The FG5 absolute gravimeter is a typical example of recent absolute gravity instruments. The FG5 has a test mass which is dropped vertically by a mechanical device inside a vacuum chamber, and then allowed to fall a distance of 20 cm (Fig. 2-1). The FG5 uses a laser interferometer to accurately measure the position of the free-falling test mass as it accelerates due to gravity. The laser interferometer generates optical interference fringes as the test mass falls [Nassar, 1969]. Multiple position-time data pairs collected during the drop provide an overconstrained solution to the equation of motion. The FG5 typically collects 200 data pairs over a drop length of 20 cm (0.2 s duration); a single observation session consists of several thousands drops [Niebauer, et al. 1995]. An attached PC computer controls data acquisition and performs real-time processing of the gravity data. The FG5 has a higher level of robustness, reliability and an instrumental uncertainty estimate of 0.0011 mGal [Niebauer, et al. 1995].

2.3.2 Relative gravimeters

Generally, the relative gravity instruments can be divided into two main groups based on the method of observations. The first method is the dynamic method, based on observing the oscillation time of sensors such as the relative pendulum. This method, introduced in 1887, is no longer be used

except for special tasks [Torge, 1989a]. The second method is the static method where an equilibrium is maintained between the force of gravity

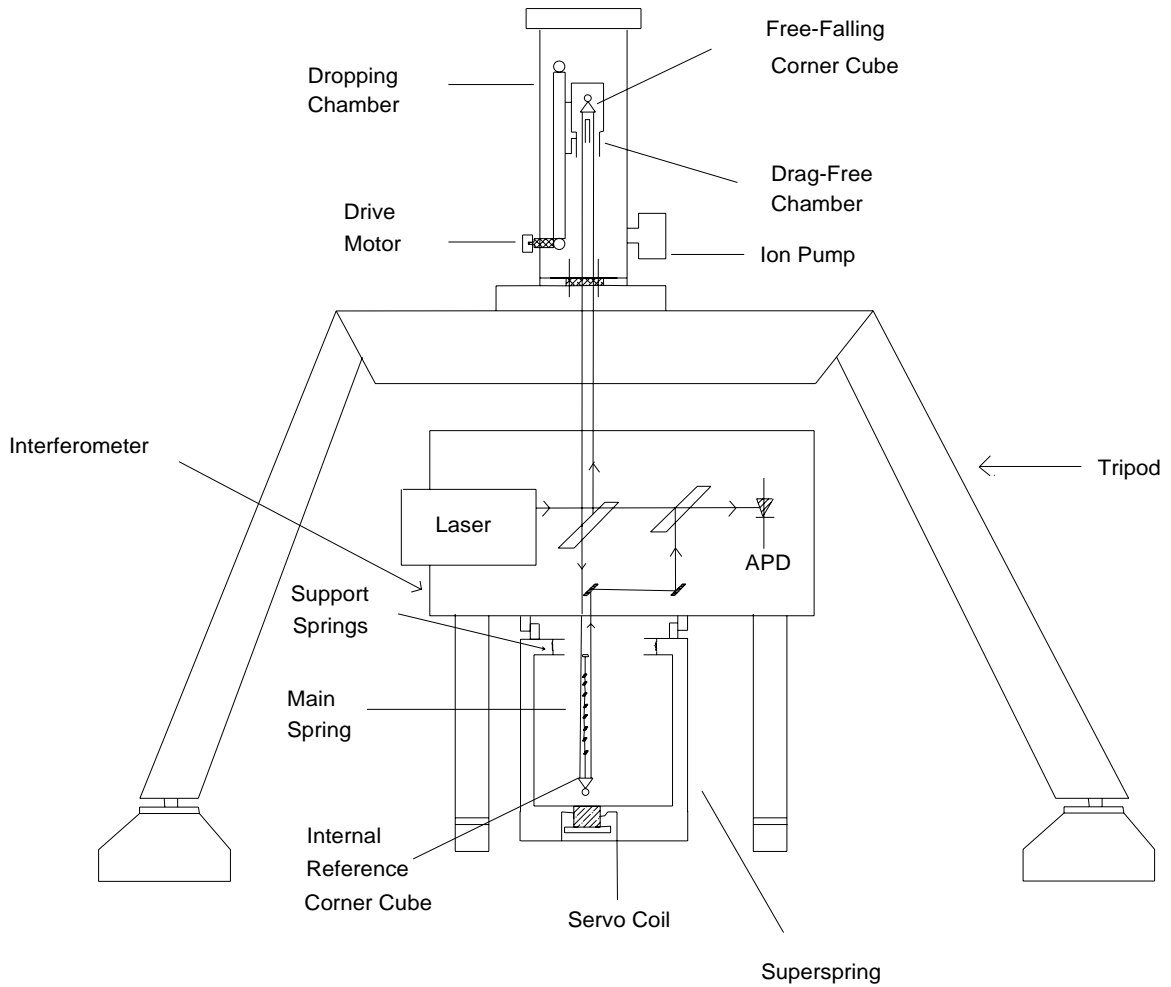

Fig. 2-1

The FG5 Absolute Gravimeter

acting on a test mass and a measurable-counter acting force. Elastic springs are used to generate this counter force. There are several examples of the static method instruments such as the vertical-spring devices and the lever torsion spring gravimeters.

A third group of the static method which is based on the principle of astatization. Astatization is caused by approximating the torque characteristics of gravity force and spring force. This type of relative gravimeters was invented by the French expert LaCoste in 1934 [Tsuboi, 1979]. For the spring, a wire is wound in one plane in the form of a spiral (Fig. 2-2). This spring is called a zero-length spring because its length is “zero” when it does not carry a mass. The original clockwise moment (M_s) due to the gravity force acting on the spring is:

$$M_s = m g a \sin \theta \quad (2-1)$$

where:

m is the mass,

g is the gravity acceleration,

a is the distance to the mass , and

θ is the displacement angle from the vertical.

When the end of the spring is moved from position O to position r (Fig. 2-2), the clockwise moment (M_ϵ) due to the elastic force of the spring is:

$$M_\epsilon = - \epsilon b h \sin \theta \quad (2-2)$$

where ϵ is the spring’s elastic constant.

The total moment M acting on the spring is therefore:

$$M = M_s + M_e = (m g a - \varepsilon b h) \sin \theta \quad (2-3)$$

The equilibrium exists when the difference of the torques due to gravity force and due to spring force is zero, i.e. ($mga - \varepsilon bh = 0$). Choosing the instrumental constants (a , b , h , m , and ε) appropriately yields a very long period of oscillation and the equilibrium position will react sensitively to a small change in gravity, so that it can be used in precise relative gravimetry. Worden, North Americans, and LaCoste and Romberge (LCR) gravimeters are some examples of the instruments falling into this group of the static devices. In the present research, both LaCoste and Romberge relative gravimeters model G and D, are used in all relative gravity measurements performed at the ENGSN-97 stations. Therefore, some more details about LCR gravimeters will be essential at this stage, and will be presented in the remainder of this section.

The LaCoste and Romberge (LCR) relative gravimeters are used worldwide in establishment of gravity networks. They are available in two models:

- Model G gravimeters with a worldwide (7000 mGal) range of observation and a precision of better than 0.04 mGal.
- Model D gravimeters with a 200-mGal range (but has a re-setting screw) and a precision of better than 0.01 mGal [Torge, 1989a].

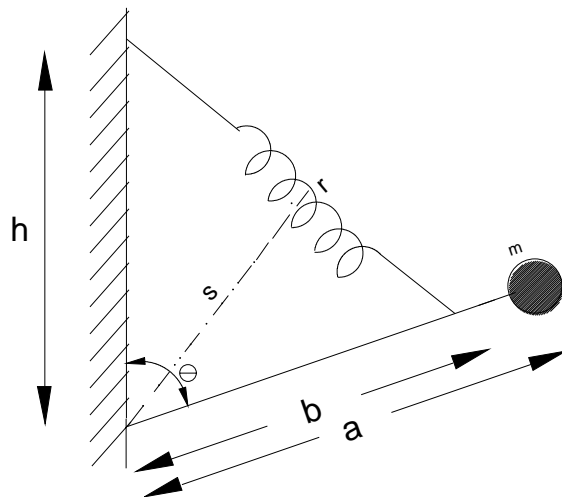
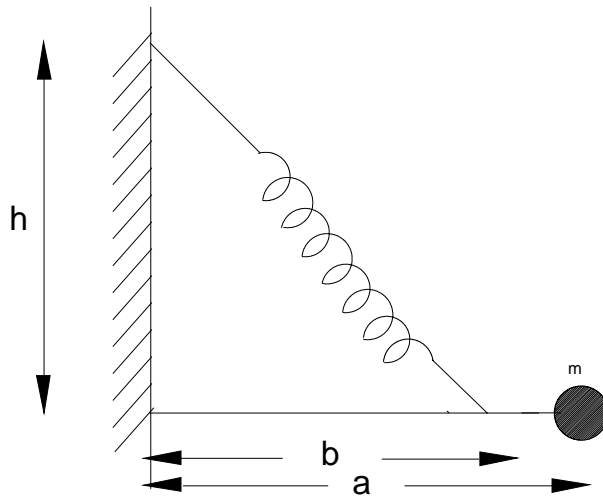

Fig. 2-2

The Astatization Principle

Figure (2-3) presents a simplified diagram of the LCR gravimeters where there is a mass at one end of a horizontal beam and on the other end there is a pair of fine wires and springs that act as a frictionless hinge for the beam [LaCoste and Romberge, 1989b]. The beam is supported from a point just behind the mass by a zero length spring, which is at an angle of approximately 45 degrees from the horizontal. Three levelling screws are used to adjust the long and the cross levels to ensure the horizontal position of the meter.

The gravimeter is read by nulling the mass position, i.e., adding or subtracting a small amount of force to the mass to restore it to the same reading position, which is called the gravimeter's reading line. This is done by lifting up on the top end of the zero length spring using a series of levers. The levers are moved by a high-precision screw, which in turn is rotated by a gearbox. When the gravimeter is not in use, the beam is clamped. The length of the main spring in the clamped position is exactly the same length as it is when unclamped and at the reading line. The gravimeter is installed in a double metal shielding to isolate it from magnetic fields and its interior is sealed from the outside air to prevent changes in air pressure. As an additional precaution, if the seals fail, there is a buoyancy compensator on the beam.

The LCR gravimeters can be operated on either a 12-volt battery or directly on 115 or 230 volts AC power through a charger-eliminator device. From about two to five hours are required to reach the operating temperature depending on how cold the gravimeter is. Then, the power will cycle on and

off as needed to maintain the constant temperature. Each gravimeter has its own operating temperature and reading line which are recorded in the manual. A calibration table is provided with each gravimeter to convert its dial readings into milligal units over several parts of the gravimeter range. Table (2-2) presents an error budget for LCR gravimeters in normal gravity campaign procedures [Torge, 1989b].

Table 2-2
The Error Budget for LCR Relative Gravimeters

Error Source	Error Value (mGal)
[1] Instrumental:	
Reading	0.003
Levelling	0.005
Elastic aftereffects	0.005
Voltage source	0.005
[2] Periodic Calibration component:	
Model G	0.015
Model D	0.002
[3] External effects:	
Temperature	0.010
Air pressure	0.001
Magnetic field	0.003
Shocks	0.010
[4] Temporal gravity changes:	
Tides	0.010
Air pressure	0.005
Ground water	0.005
[5] Total Error:	
Random + Systematic error component:	
Model G	0.027
Model D	0.022
Including temporal gravity changes:	
Model G	0.030
Model D	0.025

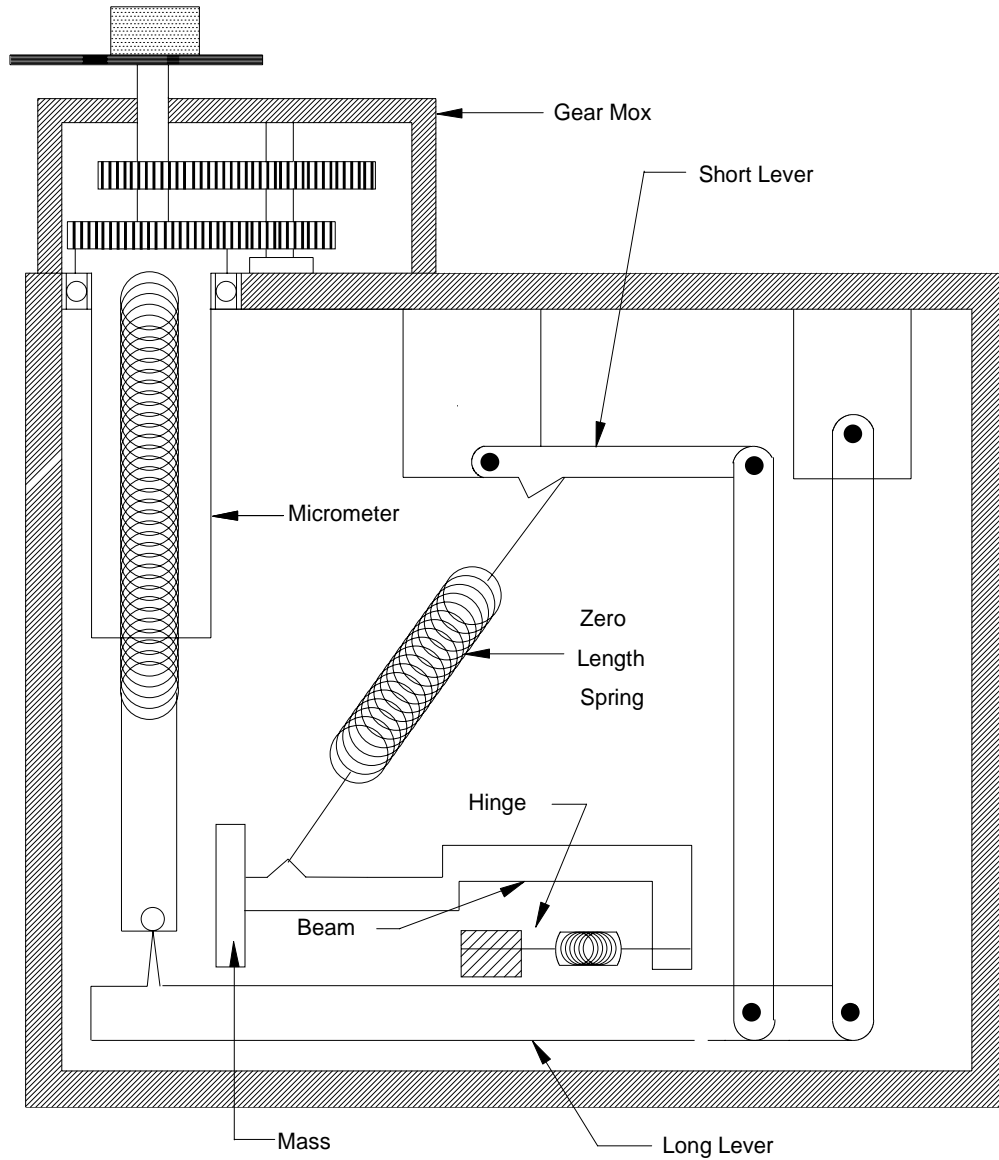

Fig. 2-3
The LaCoste and Romberg Gravimeter

2.4 Gravity observation techniques

The basic survey procedure in gravity surveying is the loop. This procedure is required to computationally remove the systematic drift error of the instrument and to provide redundant observations at stations for quality assurance purposes. A loop consists of a set of gravity stations, for which gravity differences are observed by the same observer and the same gravimeter. The gravimeter must be in its operating temperature for at least six hours prior to the loop observations and remains at this condition during the observation time for the entire loop. The loop must start from a station with known gravity value.

Relative gravimeters exhibit a temporal variation in the display of the zero position, which is called the instrument drift. The drift is a function of several factors, such as the structure of the gravimeter, the age and usage of the instrument, external temperature variation during transportation and measurements, and uncompensated change of voltage of the power supply. The drift can be determined by repeated measurements, which should be distributed as uniformly as possible over the measurement period. Therefore, various measurement schemes were developed particularly for drift control. The following are some examples of the useful observation methods (Fig. 2-4) [Torge, 1989a]:

- * Difference method with immediate drift control in the endpoint of each gravity difference, station sequence:
1-2-1, 1-2-1-2, 1-2-1-2-1-2, etc.
- * Star method with ties to a central point and immediate drift control, station sequence:
1-2-1-3-1-4-1
- * Step method with at least triple station occupations in quick successions, sequence:
1-2-1-2-3-2-3-4-3
- * Profile method with single, double, or multiple station occupation at continuous station occupation in the profile, sequence:
1-2-3-4 ... 4-3-2-1

2.5 Gravity processing models for some selected networks

The different processing approaches, that have been utilized in some selected national and international gravity networks, are presented here, just as an example for illustration purposes. The IGSN-71 is selected as a well-known international gravity network, whereas both the NGSBN-77 and JGSBN-90 are selected as examples of national networks in Egypt and Jordan, respectively. The main objective here is to gain some experience from those previous adjustments, aiming to give us some guide lines in deciding upon the best adjustment model for our Egyptian gravity network ENGSN97.

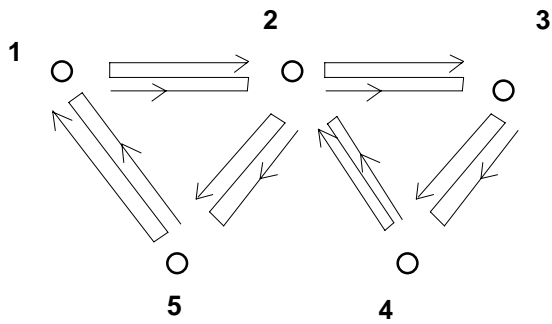

(A) The Difference Method

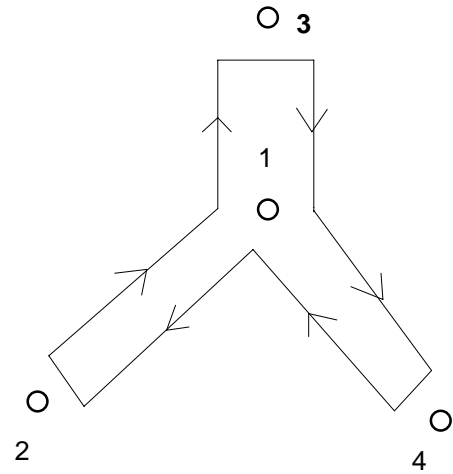

(B) The Star Method

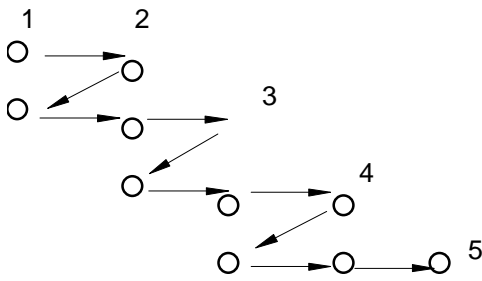

(C) The Step Method

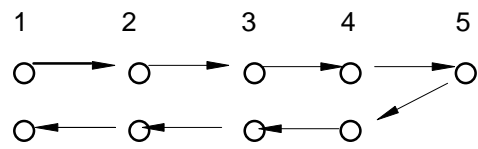

(D) The Profile Method

Fig. 2-4

The Gravity Observations Schemes

2.5.1 The International Gravity Standardization Network 1971 (IGSN-71)

Three individual scientific groups have carried out three adjustments for the International Gravity Standardization Network 1971 [Morelli et al, 1971]. Such adjustments are called: adjustment 1 by Uotila, adjustment 2 by Whalen, and adjustment 3 by McConnell and Gantar. The differences between these adjustments are the procedures used for selection, weighting and rejection of data. A summary of the main characteristics of these adjustments is given in Table 2.3. The modeling approaches, for gravity difference observation equations, used in the three individual adjustments, will be briefly stated here. Only the gravimeters observations are included herein since, it is not a current interest to deal with pendulum observations.

Adjustment 1 by Uotila:

The gravity difference observation equation, for the first adjustment as performed by Uotila, takes the following form:

$$d_i - d_j + k (t_i - t_j) + l (d_i - d_j) + m (d_i^2 - d_j^2) + n (d_i^3 - d_j^3) = 0 \quad (2-4)$$

where,

d_i, d_j : dial readings in mGal at stations i and j, respectively, corrected for all known systematic effects,

k : unknown coefficient for drift,

t_i, t_j : time of observation of the dial readings at stations i and j, respectively,

Table 2-3

Individual adjustments of the IGSN-71 network

	Adj. 1	Adj. 2	Adj. 3	Remarks
Selected Data Adjusted	X	X	X	4 – 600 unknowns; 7-11000 observations.
All Data Adjusted			X	2000 unknowns; 25000 observations.
Centered Data Adjusted	X	X	X	
Uncentred Data Adjusted	X partiall y		X	
1 st order meter scale unknown	X	X	X	
2 nd order meter scale unknown	X			
Scale unknown for all trips with the same meter	X	X		
Scale unknown for individual trips with each meter			X	

l : unknown coefficient for a linear scale factor term,
 m : unknown coefficient for a second order scale factor term,
 n : unknown coefficient for a third order scale factor term, and
 g_i, g_j : gravity values at the stations i and j , respectively.

There are as many equations as the number of observed gravity differences plus the number of sequentially repeated readings at the same station. For each gravimeter there are one or more drift rates, k , and one or more corrections, l , to the original linear calibration factor and one or more coefficients, n and m , for the second and the third order scale factor terms respectively, but there is only one g_i for each station.

Several least-squares adjustments were carried out. The final accepted solution depended on integrating relative and absolute measurements in a unique data processing step.

Adjustment 2 by Whalen:

The gravity difference observation equation, for the second adjustment performed by Whalen, read as follows:

$$\sqrt{p_n} (- g_i + g_j + k \Delta G_{ij} + d \Delta T_{ij} + L = v_{ij}) \quad (2-5)$$

where,

g_i, g_j : are corrections to be determined for preliminary gravity values for stations i and j ,

- d : is a drift correction factor to be determined,
 ΔT_{ij} : is the time interval in hours for the measurements between bases,
 k : is a scale correction factor to be determined,
 ΔG_{ij} : is the gravity difference between bases i and j,
 L : is the observed gravity difference minus the difference between the preliminary gravity values from bases i and j,
 v_{ij} : is the unknown observational error, and
 p_n : is the observation weight which is taken as the reciprocal of the variance for the measurement.

Four different adjustment solutions were obtained, using this approach, depending on the different combinations of observations used such as (a) using Only LCR data; (b) using only Pendulum and non-LCR data; and (c) using Pendulum, LCR, and absolute measurements together.

Adjustment 3 by McConnell and Gantar:

The observation equation model used by McConnell and Gantar approach is:

$$\sqrt{p_n} (g_i - g_j - k_m \Delta G_{ij} - d_m \Delta T_{ij} = v_{ij}) \quad (2-6)$$

where,

g_i, g_j : are unknown gravity values for stations i and j,

d_m : is the unknown drift rate,

ΔT_{ij} : is the time interval in hours for the measurements between bases,

k_m : is the unknown scale factor for the m-th instrument in a specific loop,
 ΔG_{ij} : is the gravity difference, in mGal, between bases i and j,
 v_{ij} : is the unknown observational error, and
 p_n : is the observation weight.

Smaller sections of the whole network were processed separately to investigate problems related to instrument scale factors and observation weights. Therefore, three types of adjustment solutions were carried out based on:

- * centered ties in selected blocks;
- * centered ties between world-wide selected stations; and
- * all observations between actual measurement sites.

2.5.2 The National Gravity Standard Base Network 1977 (NGSBN-77)

The NGSBN-77 has been processed in such a way where the gravity differences between two successive stations are the main observables [Kamel and Nakhla, 1985]. The observed gravity differences were transformed to gravity units using the mean calibration factor, corrected for tidal effect, and corrected for the systematic drift of the instruments. The applied mathematical model for the adjustment is based on the method of successive iteration which is based on developing a set of equations expressing the sum of the products of the weights and discrepancies of the links at a certain position in the interconnected polygons scheme. These equations can be written as follows:

$$\begin{aligned}
P_1X_1 + P_{21}X_2 + P_{31}X_3 + P_{51}X_1 - V_1 &= 0 \\
P_2X_2 + P_{12}X_1 + P_{32}X_3 + P_{42}X_4 - V_2 &= 0 \\
P_3X_3 + P_{13}X_1 + P_{43}X_4 + P_{53}X_5 - V_3 &= 0
\end{aligned}
\tag{2-7}$$

where,

P_{ij} denotes the total weights of corresponding ties.

V_i denotes the discrepancy at the interconnecting station, and

X_i denotes most probable corrections.

The weights are taken proportional to the distances between links for polygons observed using cars and proportional to the flight time for polygons observed using aircrafts. Based on this model, two sets of equations were formulated for both polygons observed using vehicles and those observed using airplanes, then the adjusted values for each base point was obtained for each side of a polygon.

2.5.3 The Jordanian Gravity Standardization Network 1990 (JGSN-90)

The Jordanian Gravity Standardization Network 1990 (JGSN-90) consists of 34 gravity stations established by the Canadian Scintrex Limited Company using two LaCoste and Romberge gravimeters [Scintrex, 1990]. The mathematical model applied is:

$$g_i - g_j - k_{11} (r_i - r_j) - k_{21} (r_i^2 - r_j^2) - d_q \Delta T_{ij} = v_{ij} \tag{2-8}$$

where,

g_i, g_j are known gravity values for stations i and j .

r_i, r_j are the gravity readings at stations i and j , respectively, corrected for all known instrumental and environmental effects.

d_q is the unknown drift rate for the q -th drift interval.

ΔT_{ij} is the difference in time between readings at stations i and j .

k_{1l} is the unknown coefficient for first order scale factor for the l -th instrument.

k_{2l} is the unknown coefficient for second order scale factor for the l -th instrument.

v_{ij} is the unknown observational error.

The least-squares adjustment was utilized to estimate the previous mentioned unknowns in the observation equations. A simple criteria is used to reject erroneous observations and, then, the adjustment is recycled.

2.6 Gravimetric reductions of terrain geodetic measurements

It is a matter of fact that the geodetic terrestrial measurements are observed relative to the actual gravity vertical (plumb line), as a consequence of using surveying instruments which are all levelled by a spirit level, that is always adjusted and oriented to the actual local gravity field of the Earth. On the other hand, these observations are needed for the purpose of position computations of geodetic points on the reference ellipsoid, i.e., relative to the ellipsoidal normal. The deflection of the vertical is the angular deflection between the actual gravity vertical and the ellipsoidal normal at a

specific point (Fig. 2-5). This angle is divided into two components in the meridian and prime vertical directions and denoted by ξ and η respectively.

Gravity measurements are used in estimating the values of the deflection of the vertical needed to reduce terrestrial observations. Some examples of these reduction computations are [Nassar, 1984]:

(A) Reduction of astronomic azimuth

The difference between the observed astronomic azimuth from point 1 to point 2 (A_{12}) and the reduced azimuth in the local geodetic system (α_{12}) is given by:

$$\alpha_{12} - A_{12} = -\eta_1 \tan \varphi_1 - (\xi_1 \sin \alpha_{12} - \eta_1 \cos \alpha_{12}) \tan v_{12} \quad (2-9)$$

where v_{12} is the vertical angle in the local geodetic vertical plane, and

φ_1 is the geodetic latitude of station 1.

(B) Reduction of vertical angle

The difference between the observed vertical angle in the local astronomic vertical plane from point 1 to point 2 (V_{12}) and the reduced vertical angle in the local geodetic vertical plane (v_{12}) is given by:

$$v_{12} - V_{12} = -(\xi_1 \cos \alpha_{12} + \eta_1 \sin \alpha_{12}) \quad (2-10)$$

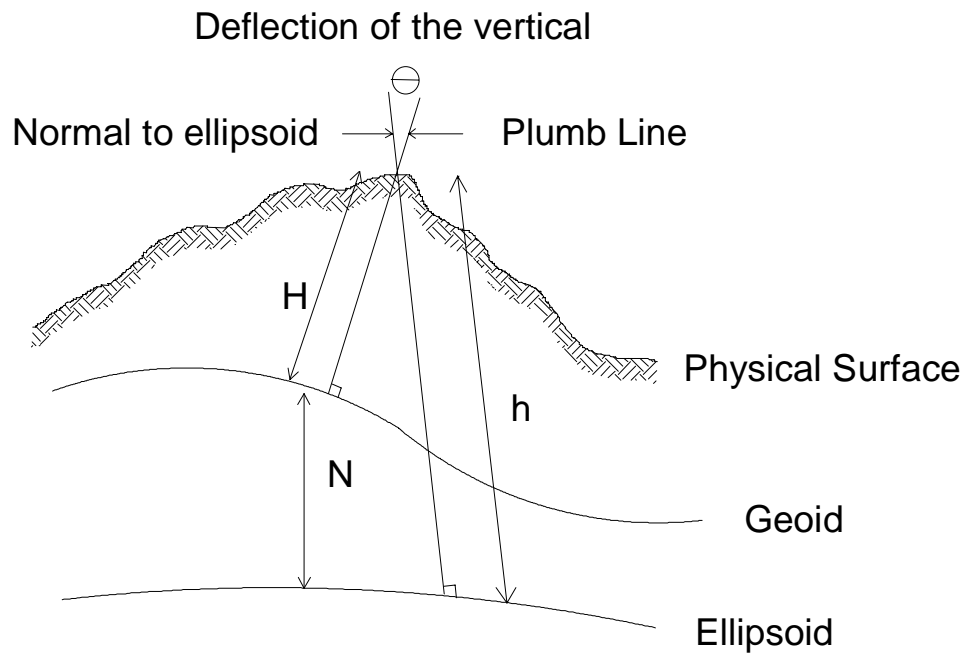

Fig. 2-5

Orthometric and Ellipsoidal Heights

(C) Reduction of horizontal directions

The difference between the observed direction between two terrain points 1 and 2 (T_{12}) and the corresponding reduced direction of the reference ellipsoid (t_{12}) is given by:

$$t_{12} = T_{12} + \Delta T_{12}$$

where,

$$\Delta T_{12} = - (\xi_1 \sin \alpha_{12} - \eta_1 \cos \alpha_{12}) \tan v_{12} + \zeta [(h_2 / 2 M_m) e^2 \sin 2\alpha_{12} \cos^2 \varphi_2] - \zeta (S_{12} / N_m)^2 (e^2 / 12) \sin 2\alpha_{12} \cos^2 \varphi_2$$

$$\zeta = 206265''$$

M_m : radius of curvature in the meridian plane,

N_m : radius of curvature in the prime vertical plane, and

S_{12} : the ellipsoidal geodesic distance between the two points.

(D) The relation between ellipsoidal and orthometric heights

The relation between the ellipsoidal height (h) and the orthometric height (H) is the geoid undulation (N) :

$$N = h - H \tag{ 2-11}$$

2.7 Gravity anomalies

In common practice, for geodetic and geophysical applications, one usually does not work with either the gravity acceleration value g , or even its corresponding potential W , as observed or determined at the terrain surface within the area of interest. Instead, more interest is oriented upon the interpolation of the irregularities in the earth gravity field within the same area under consideration, which is known in practice as the anomalous gravity field. Such anomalous field, is the difference between the actual gravity field as generated by the actual figure of the earth, on which we are living, and the normal gravity field as generated by the normal figure of the earth, which is an imaginary theoretical surface taken as a mean earth ellipsoid, representing the first approximation to the actual figure of the earth. The best equipotential surface describing the actual gravity field will be the geoid, while the corresponding normal surface is the surface of the mean earth ellipsoid itself. Consequently, the problem of investigating the anomalous gravity field, can be reduced to the comparison of actual gravity field parameters at the geoid, and the corresponding normal gravity field parameters at the mean earth ellipsoid. The basic elements of the anomalous gravity field include: gravity anomalies, height anomalies, disturbing potential, deflection of the vertical, geoid undulations, ... etc [Nassar, 1976]. However, in the present study, we are going to deal with the gravity anomalies, deflection of the vertical, and geoid undulations only, particularly for geoid computations and analysis as will be given in chapter 6, which presents one major geodetic application of the established ENGSN-97

network. The main concept of the different types of gravity anomalies, will be introduced in this section.

The gravity anomaly, Δg , is the difference between the observed gravity value (g) reduced to the geoid, and a normal, or theoretical, computed gravity value (γ_o) at the mean earth ellipsoid, where, the actual gravity potential on the geoid equals the normal gravity potential at the ellipsoid, at the projections of the same terrain point on the geoid and the ellipsoid respectively, that is:

$$\Delta g = g - \gamma_o \quad (2-12)$$

The normal gravity is computed based on an internationally-adopted reference ellipsoid. The most recent adopted system is the Geodetic Reference System 1980 (GRS80) with the following constants:

- e^2 : square of the first eccentricity = 0.00669438002290
- g_e : normal gravity at the equator = 978032.67715 m/s²
- a : semi-major axis = 6378137 m
- f : flattening = 0.00335281068118

The equation of computing the normal gravity value on the GRS80 is given by [Torge,1989]:

$$\gamma_o = g_e * ((1 + 0.001931851353 * \sin^2 (\varphi)) / \sqrt{ (1 - e^2 * \sin^2 (\varphi)) }) \quad (2-13)$$

in which φ is the geodetic latitude of the point under consideration.

In order to get the gravity anomaly on geoid, one has to suppress the effect of the masses above it. Based on the way of treating these masses between the terrain and the geoid, there are several types of gravity anomalies. The most important gravity anomalies are the free-air anomaly, the Bouguer anomaly, and the isostatic anomaly. The simple formulas of those gravity anomalies will be given, without derivations, in the remainder of this section [Vanicek, 1975].

2.7.1 The free-air gravity anomalies:

The free-air reduction is based on a simple assumption, that is, there are no masses above the ellipsoid, so the observation station is imagined to be hanging free in the air. The free-air gravity anomaly is given by:

$$\Delta g_{\text{FA}} = g + \delta g_{\text{F}} - \gamma_0 \quad (2-14)$$

where,

δg_{F} : the free-air correction in mGal = 0.3086 H,

H : the orthometric height in meter, and

g : the observed gravity value on the terrain.

γ_0 : the computed normal gravity on the surface of the mean earth ellipsoid, at the latitude of the point.

2.7.2 The Bouguer gravity anomalies:

The free-air treatment of gravity does not depict the reality well enough. Obviously, when observing the gravity on the surface of the earth, its value is influenced by the masses in between the topographic surface and the geoid as well as by the masses enclosed within the geoid. This influence of the masses above the geoid should be corrected for as well. It is usually done in two steps:

- (i) removal of the influence of the plate of uniform thickness H meter high;
- (ii) removal of the influence of the irregularities of the topography; i.e., the influence of the masses enclosed between the topographic surface and the flat surface of the plate.

The first step deals with the so-known Bouguer plate according to the French geodesist Bouguer who first used this correction in 1749. The second step, considered as a refinement of the first one, is known as terrain correction.

Assuming a plate of infinite extension and thickness H, the simple Bouguer gravity anomaly is given by:

$$\Delta g_{SB} = g + \delta g_F + \delta g_B - \gamma_o \quad (2-15)$$

where,

δg_B : the simple Bouguer correction = - 0.1119 H (assuming the density of the earth crust = 2.67 gram/cm³).

The second step in evaluating the influence of the masses between the geoid and the topographic surface consists of accounting for the masses trapped between the Bouguer plate and the surface. The terrain correction corresponds to a cut or fill of topographic masses in order to generate the model of a Bouguer plate (Fig. 2-6). At A, the mass surplus Δm_+ , which attracts upward, is removed, causing the gravity value at point P to increase. At B, the mass deficiency Δm_- is made up, causing the gravity at P to increase again. Therefore, the terrain correction is always positive. In general, a Digital Terrain Model (DTM) in a geographical or plane cartesian coordinate grid is used for extensive computations. The terrain correction is computed from the gravitation of rectangular prisms, and can be performed economically in the spectral domain by Fast Fourier Transforms (FFT). The magnitude of terrain correction is usually of the order of a few tenths of a mGal for flat and gently rolling areas. It reaches a few mGal in a hilly area and tens of mGal in the mountains [Schwarz, et al, 1990]. Hence, neglecting the terrain correction introduces a systematic bias in the computation of gravity anomalies.

Therefore, the complete Bouguer gravity anomaly is given by:

$$\Delta g_B = g + \delta g_F + \delta g_B + \delta g_T - \gamma_0 \quad (2-16)$$

where,

δg_T : the terrain correction.

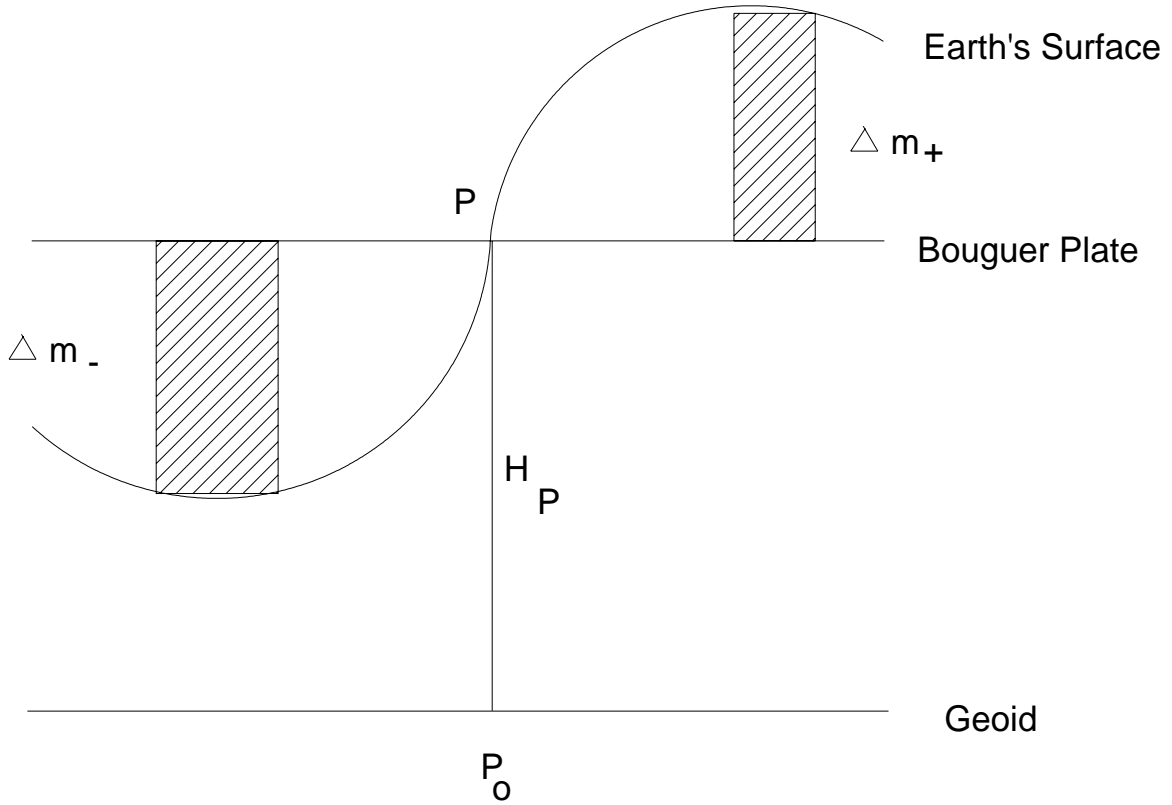

Figure 2-6

Bouguer Plate and Terrain Correction

2.7.3 Isostatic Gravity Anomaly

If the earth is of homogenous crust, the Bouguer reduction would remove the main irregularities of the gravity field, so that the Bouguer anomalies would be small and would fluctuate randomly around zero. However, just the opposite is true and the Bouguer anomalies in mountainous areas are systematically negative and may attain large values, increasing in magnitude on the average by 100 mGal per 1000 meters of elevations [Heiskanen and Moritz, 1967]. The only explanation possible is that there is some kind of mass deficiency under the mountains, and thus it means that the topographic masses are compensated in some way.

Isostasy is the theory of equilibrium of the earth crust. The principle of isostasy was probably originated by Leonardo da Vinci, but the first mathematical formulation can be found in the theories of J.M. Pratt (1854) and G.B. Airy (1855). There are several models of the isostatic reductions, but the more realistic one is that of Vening-Meinesz. Pratt's model of isostasy is based on dividing the earth into more or less independent blocks of different density, and considering those blocks as floating on the level of magma that lies in a certain depth, which is called the compensation level. This isostatic model was used by Hayford (1912) for smoothing the gravimetric deflection of the vertical for the purpose of determination a mean earth ellipsoid. Another isostatic model, called Airy's model, is based on the analogy of the earth crust blocks with icebergs, assuming a constant density for all the individual blocks which, sink differently into the plastic magma according to their heights. Vening-Meinesz isostatic model regards

the crust as an elastic homogenous layer of variable thickness. The mean thickness is assumed to be about 30 Km, and the mathematical description of the model is based on the theory of elasticity, taking into account that the earth crust has a variable density and a variable thickness. Mathematical formulation of different isostatic reduction models can be found in many literature [e.g. Hieskanen and Moritz, 1967]. The isostatic gravity anomaly is given by:

$$\Delta g_I = g + \delta g_F + \delta g_I - \gamma_0 \quad (2-17)$$

where,

δg_I : the isostatic correction.

2.7.4 A Discussion of Different Types of Gravity Anomalies

For the Bouguer and the isostatic gravity anomalies, the masses above the geoid are actually disregarded, which indicates that there exist a change of the real distribution of the masses and, consequently, the potential of the earth and even the geoid. This distortion is called the indirect effect of the mass removal and the surface thus distorted is known as co-geoid. The co-geoid is reduced to the geoid by evaluating the indirect effect all over the earth surface. The free-air gravity anomaly can be considered as the first approximation to the isostatically compensated anomaly. In addition, the free-air reduction is very simple to compute and has no indirect effect since this type of reduction do not manipulate with the masses at all. These are the two reasons why the free-air gravity anomaly is used almost exclusively for

several geodetic applications such as the gravimetric determination of the geoid. To some degree of approximation, it can be said that the co-geoid produced by the free-air gravity anomalies coincides with the actual geoid.

The Bouguer gravity anomaly is very useful for geophysical prospecting because it varies very smoothly and reflects the local gravity irregularities in the most useful manner. On the other hand, the Bouguer gravity anomaly has a huge indirect effect and, therefore, is not recommended for geoid determination. The isostatic gravity anomaly is obviously the most truthful representation of the nature and would be theoretically the best anomaly type for geoid determination. However, this type of anomaly is complicated and require a good knowledge about the variable density and thickness of the earth crust. In other words, in order to apply the isostatic anomaly, a reliable Digital Density Model (DDM) must be available, beside the Digital Terrain Model (DTM), beforehand.

Chapter 3

The establishment of the Egyptian National Gravity Standardization Network 1997 (ENGSN97)

The establishment and re-calibration of the Egyptian National Gravity Standardization Net (ENGSN97) is a project initiated in late of 1994 between:

- * Survey Research Institutes (SRI) as the executive counterpart with the cooperation of the General Petroleum Company (GPC), and
- * The Egyptian Academy of Scientific Researches and Technology as the financial and supervisory organization.

The project aims to [SRI, 1995] :

- 1- Establishment of a fundamental national gravity network for Egypt.
- 2- Updating of the gravity-anomalies maps of Egypt.
- 3- Recent and accurate definition of the figure of the earth, the geoid, in Egypt and the use of gravity values in determining geoid undulations and the components of the deflection of the vertical necessary for the reduction of geodetic observations.

According to the ENGSN97 project's goals, the field observation campaigns include the collection of three types of measurements: relative

gravity, GPS coordinates, and precise levels. This is, of course, beside the necessary absolute gravity measurements at some selected stations. Consequently, each ENGSN97 station has known precise values of:

- * gravity acceleration (g),
- * geodetic latitude (ϕ),
- * geodetic longitude (λ),
- * geodetic height (h), and
- * orthometric (H) heights.

In this chapter, the basic items connected with design, and field measurements of the ENGSN97 network will be discussed. Firstly, the design and monumentation of the network's stations will be given, Then, the gravity measurements, including both relative and absolute observations, will be introduced. Finally, the station positioning measurements, using both the Global Positioning System (GPS) technology and the precise levelling technique, will be outlined.

3.1 Design of the ENGSN97 network

The ENGSN97 network is thought as the fundamental national gravity network for Egypt that could be used in a variety of applications such as: determination of the geoid in Egypt, crustal movement studies, geodetic computations, mineral and oil exploration process, and scientific and academic researches.

The design criteria of the ENGSN97 network includes:

- Homogeneous distribution of gravity stations over the Egyptian territories.
- The inclusion of the National Gravity Standard Base Network 1977 (NGSBN-77) stations.
- Using precise LaCoste and Romberge gravimeters to measure the relative gravity observations.
- Following the standards and specifications of the International Bureau of Gravity (IGB).
- As a regional network, the station separations are less than 100 km, according to the international specifications as given in section 2-2.
- Permanent monumentation.
- Accessible locations with geological, seismic, and hydrological stability.
- 3-D coordinates determination using GPS technology.
- Orthometric height determination, using precise levelling technique, tied to the first-order national Egyptian vertical datum.

Regarding the above conditions, a design of the ENGSN97 has been optimized as depicted in Fig. (3-1).

Prior to starting the field campaigns, a reconnaissance survey has run and showed that, unfortunately, almost all of the NGSBN-77 stations (Fig. 1-2) have been lost, except about five stations only. Therefore, it was decided to re-establish the NGSBN-77 stations at the same locations as long as the station selection conditions are satisfied. In areas where new infrastructures have been built, new locations are selected as close as possible to the old locations. In addition, the reconnaissance showed also that most of the IGSN-71 stations (Fig. 1-1) have been lost except two

stations at Helwan Observatory (station number 10591-B and 10591-C). The loss of all those important previously-established gravity stations causes, of course, additional costs and time wasting, in the design and establishment of the new ENGSN97 network.

3. 2 Monumentation

To select a location that is suitable for establishing a gravity station in the ENGSN97 net, the following conditions should be fulfilled:

- * Stable in terms of structural, hydrological, and geological conditions.
- * Away from highways, railroads, electrical power supplies, ... etc.
- * Accessible 24 hours a day, 7 days a week.
- * Suitable for setting up gravimeters, GPS receivers, and precise levelling Invar rods.
- * Existence of electrical power source.

Each station is established by a rectangular prism with a 60x60 cm base, and a height of 100 cm, buried under the ground surface (Fig. 3-2A). In the center of this rectangular prism, there is a 10-cm-diameter one-meter length steel pipe covered with a brass cover in which some information (including the Survey Research Institute name and the project name) is engraved (Fig. 3-2B).

3.3 Absolute gravity measurements

Relative gravity observations suffer from the problems with calibration, range, and drift, as mentioned in section 2-3-2. Absolute determinations of gravitational acceleration can resolve these instrument issues (section 2.3.1). Five absolute gravity stations have been established and observed to serve as an absolute gravity framework for the ENGSN97 network. The measurements have been done by a team work from the U.S. Defense Mapping Agency (DMA) in April 1997. The locations of these sites are: Giza, Helwan, Marsa Matrouh, Aswan, and El-Kharga (Fig. 3-1). The following specifications and requirements have been fulfilled in choosing the sites of absolute gravity stations:

- * Indoor locations, free from vibration.
- * Good temperature stability (variation less than 3° C)
- * Solid floor conditions.
- * Continuous electrical power.

The measurements have been carried out using the FG5 (serial number 205) absolute gravity meter (Fig.2-1). The FG5 instrument has a higher level of robustness, reliability and an instrumental uncertainty estimate of 0.0011 mGal [Niebauer, et al. 1995].

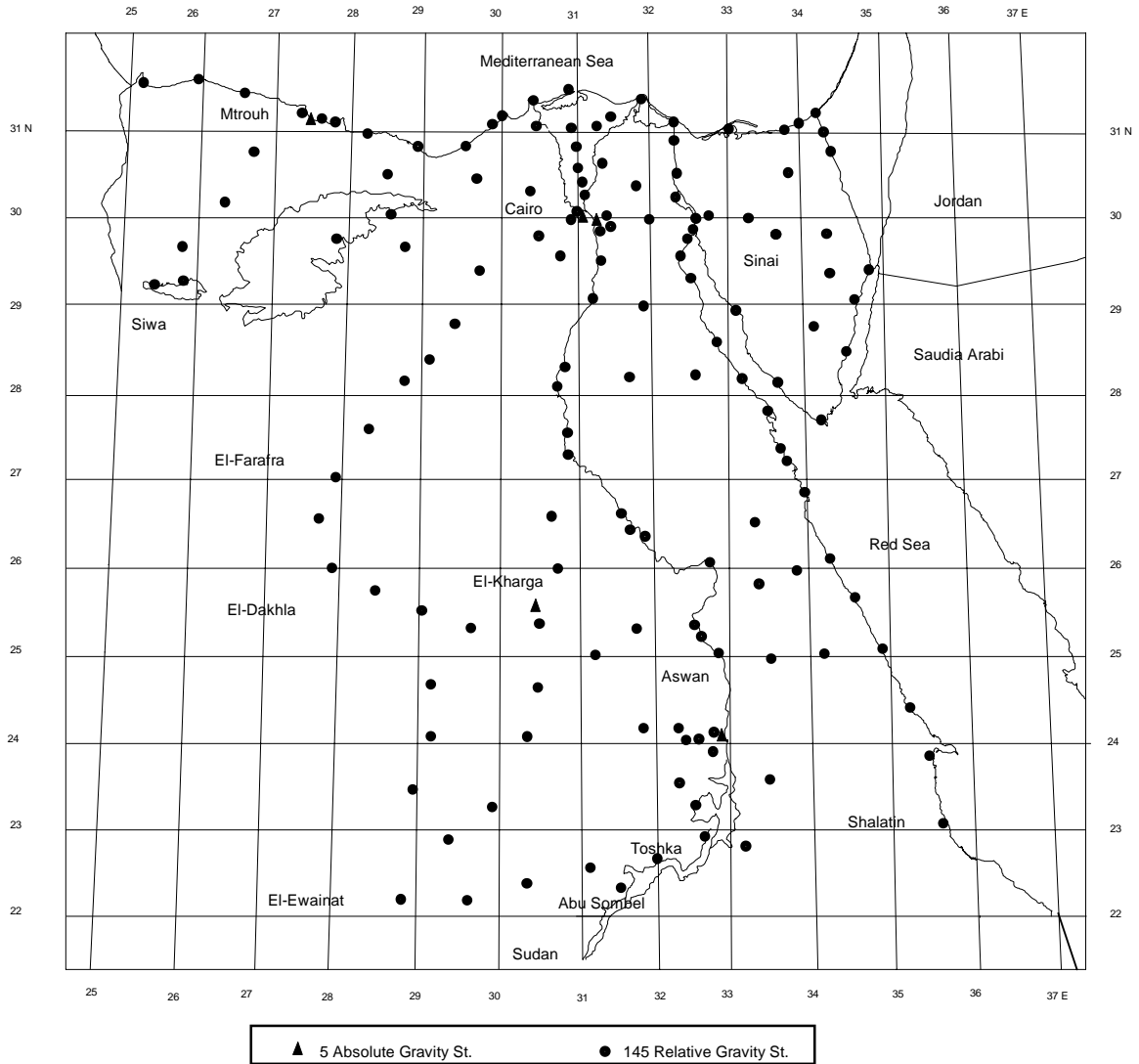
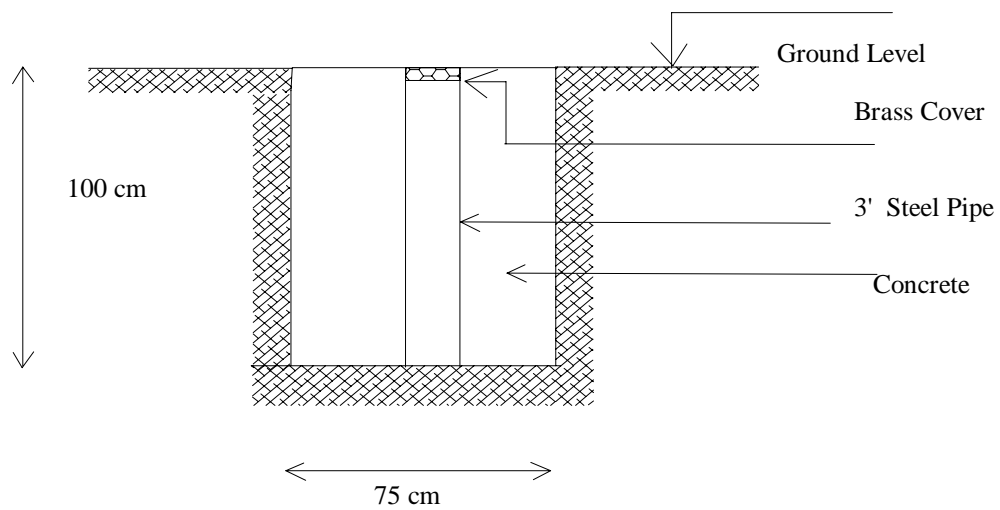

Fig. 3-1

The Egyptian National Gravity Standardization Network “ENGSN97”



(A) A cross-section



(B) The brass cover

Fig. 3-2

The monumentation of the ENGSN97 network

In each observed site, 4800 drops have been collected in a 24-hour session. The processing of the collected data has been carried out in the DMA, using special software pertaining to this particular instrument. The final results, in terms of, gravity acceleration values along with their precision estimates, have been issued to SRI in a later stage. High precise geodetic coordinates of each site have been obtained using point positioning GPS sessions of at least 24 hours of satellites tracking. The orthometric heights of all sites have been obtained through precise levelling.

From figure 3-1, one can easily notice that, the five absolute gravity stations have been located over the Nile valley and western desert. Of course, it would be better if the absolute gravity stations be increased more than five, with an even distribution over the Egyptian territory. However, it was unfortunate to satisfy such a requirement, due to the very limited time of the U.S. DMA mission in Egypt.

3.4 Relative gravity measurements

Some regular checks must be performed to the gravimeters to insure that the levels and sensitivity setting are in proper adjustment. These checks were performed prior to each field campaigns in ENGSN97 network. The first check is to insure that the cross level of the gravimeter is exactly in the horizontal position when its bubble is in its mid range. This test is quit important since if the gravimeter is tipped to one side or the other, it will not measure the full force of gravity. The second test is to check the sensitivity of the reading line. The reading line could be high sensitive or low sensitive

which cause uncertainties in adjusting the cross hair during the gravity campaign. Checking the reading line value itself is the third test which should be carried out. These tests are a must to insure that the gravimeter is adjusted and will measure the gravity acceleration precisely. They can be thought of as an indicator if the gravimeter needs permanent inspections and calibration.

Four LaCoste and Romberge (LCR) gravimeters have been used mainly in measuring the relative gravity values of the ENGSN97:

- * Two model G gravimeters (G938 and G940).
- * Two model D gravimeters (D161 and D170).

The connections of the relative gravity loops to the absolute gravity stations have been carried out using seven LCR relative gravity meters, three of them (G126, G131, and G269) belong to the U.S. DMA.

Each relative gravity loop starts from a station with known gravity values previously determined from other loops. Before April 1997, several loops have been started from the IGSN-71 station at Helwan Observatory. After the establishment of the absolute gravity stations given in the previous section (on April 1997), all loops started from the nearest absolute gravity station. In general, The loop must not exceeds 72 hours of observation time. At each site, three consecutive readings of the meter are recorded in less than 5 minutes. In the data processing stage, the average of these three readings is taken as the unique observation of this station. The field work sheet, as depicted in Fig. 3-3, includes the meter number, the observer name, the date of observations, the gravity meter readings along with their recording time.

Any break in the observation scenario should be recorded precisely in the field sheet. This is an important step, since the gravimeter drift is assumed zero while the meter is in rest.

The main observation schemes that have been applied in ENGSN97 are the step method and the profile method (Fig. 2-4C and D). Both techniques are useful in controlling the gravimeters' drift. The step method is suitable for a central-point loop such as in the Delta area. The profile technique is suitable for a loop extend in one direction such as in the upper Egypt area.

As an example of an ENGSN97 gravity loop, the loop number 1 is depicted in Figure 3-4. This loop follows the step method of observations, with triple occupations of each station, starting from the IGSN-71 gravity station at Helwan observatory. The sequence of observations is:

Helwan - October 6 - Helwan - October 6 - Fayoum - October 6 -
Fayoum - Bani-Swaif - Fayoum - Bani-Swaif - (Break) - Bani-Swaif -
Helwan.

In this loop, three relative gravity meters have been utilized.

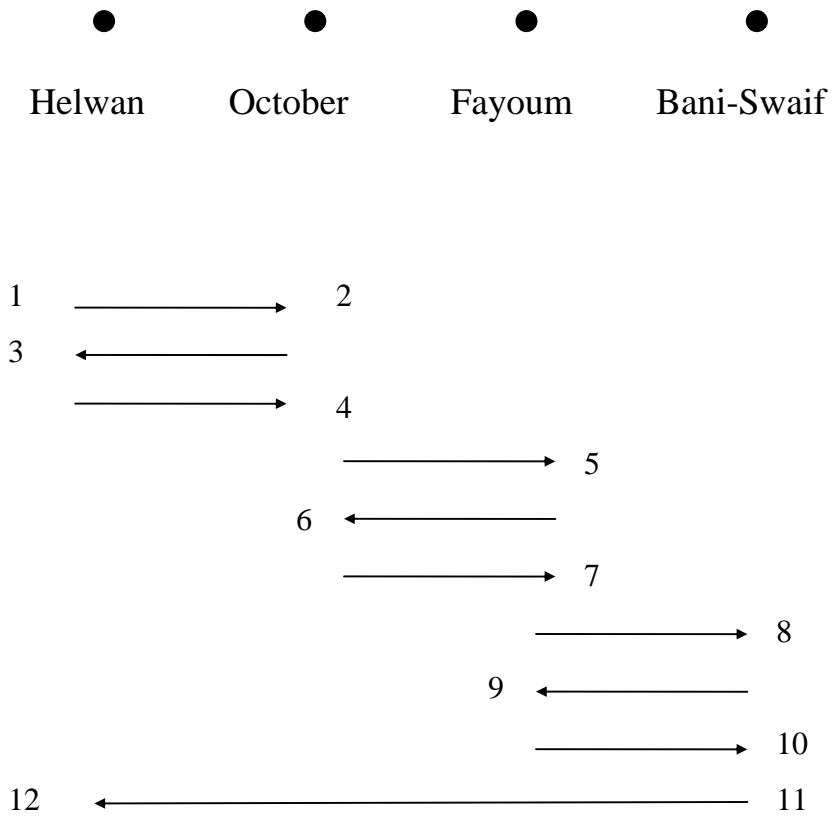

Fig. 3-4

An ENGSN97 Gravity Loop

For each gravity station in the ENGSN97 network, a description card is drawn including a sketch and a photograph of the station, as shown in Figure 3-5. The description card contains the following information: station name, location, description, 3-D coordinates, and the unadjusted gravity value.

For relative gravity observations, the GRAVPAC software from LaCoste and Romberg Inc. is used as an elementary tool for gravity data reduction. GRAVPAC is an MS-DOS program for the reduction and tabulation of gravity survey data which performs: tide computations, meter drift estimation, gravity anomalies determinations, and terrain corrections [LaCoste and Romberg, 1989]. The procedures of computing gravity values consist of several steps:

- * Convert gravimeter dial readings to milligal units by multiplying them by several factors corresponding to different portions of the instrument range.
- * Correcting the readings to the solar and lunar tide effects using the formulas of Longman but increase the tide corrections by 16% to compensate for the finite deformation or compliance of the earth.
- * Computing the net drift during the loop as the difference between the two values of the tide-corrected gravity at the base station. The drift correction is then computed at a field station reading as a linearly-prorated fraction (Fig. 3-6). If there is a break in the observation scenario, GRAVPAC assumes zero drift between these break readings.

NATIONAL WATER RESEARCH CENTER
SURVEY RESEARCH INSTITUTE

EGYPTIAN NATIONAL GRAVITY STANDARIZATION NET-1997
(ENGSN-97)

UNADJUSTED GRAVITY VALUE $G = 979320$ mGal
 STATION : SRI-24 LOCATION : Mansoura
 LOCATION : Mansoura city
 COORDINATES : Latitude : $31^{\circ} 02' 12''$ N Longitude : $31^{\circ} 23' 41''$ E Height (M.S.L.) : 7 m

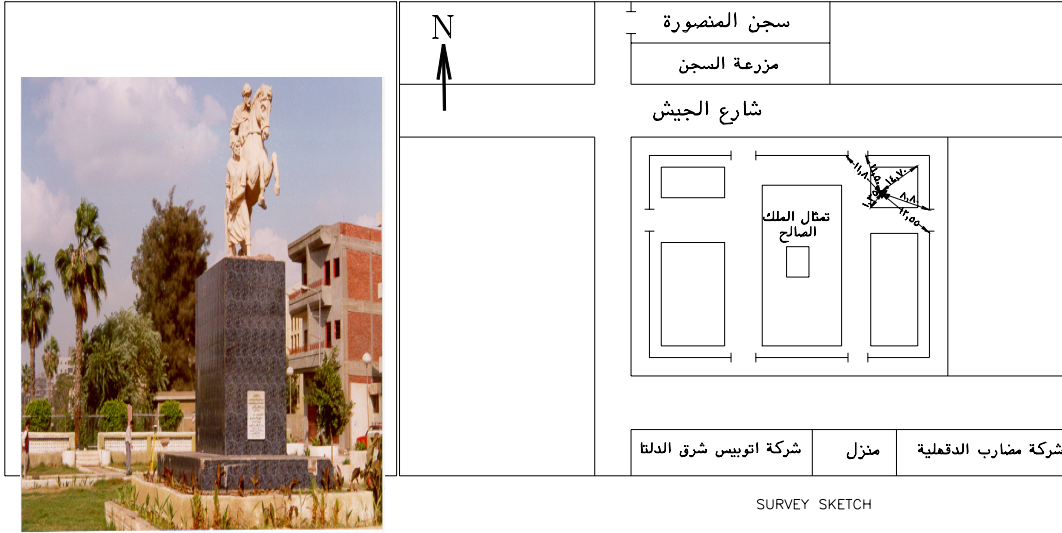

Fig. 3-5

The Description Card of the ENGSN97 stations

* The last step is adding the differences between the field station and the base station (relative gravity values) to the absolute gravity value of the base station to obtain the absolute gravity values of all stations.

Therefore, the output of the GRAVPAC software is a number of gravity values for each station equal to the number of repeated measurements at this station. There is no available commercial software for the adjustment of gravity data.

For each loop, three GRAVPAC data files are constructed for each gravity meter employed. The first file records the general information of the loop such as the meter model and number, the stations names, the time system, and comments. The second file contains the 3-D coordinates of each station, for the tide computation purposes, while the third file includes the gravimeter readings exactly as recorded in the field.

There is a set of other computer programs developed by the author for processing and adjustment of gravity measurements and will be given in the next chapter.

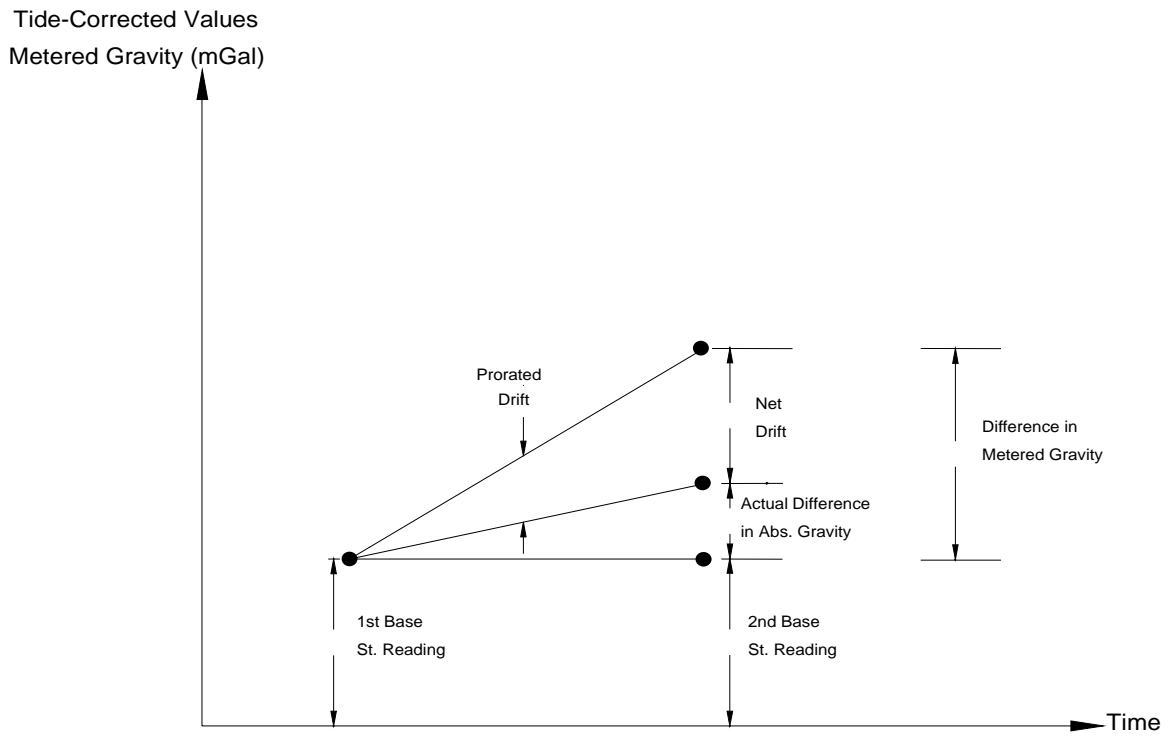

Fig. 3-6

Gravimeters Drift Computations

3.5 GPS measurements

The satellite-based Global Positioning System (GPS) is the most recent and precise positioning technology used in a variety of civilian and military applications world wide. A number of Trimble GPS receivers has been used to obtain accurate coordinates of the ENGSN97 stations. Since the station separations of the ENGSN97 network are in the average of 67 km, dual-frequency geodetic GPS receivers are used in each gravity loop. These type of receivers have a relative precision of 0.5 cm 1 part per million (ppm) [Trimble, 1996]. During each gravity loop, three or four GPS receivers are utilized in a base line or a network mode to get relative base lines components. Usually, a station from the first-order Egyptian triangulation network is observed during each loop so that the ENGSN97 stations coordinates are referenced to the national coordinates reference datum. The average session time is one hour. At least one station is fixed in the adjustment process to compute the latitude (ϕ), longitude (λ), and height (h) of all other stations. Figure 3-7 depicts an example of GPS sessions in one of the ENGSN97 loop, where three GPS receivers have been utilized. The sessions of this loop are:

Session 1: O1 - October 6 - Fayoum

Session 2: October 6 - Fayoum - Bani-Swaif

Session 3: Fayoum - Bani-Swaif - O1

Station O1, as one of the first-order horizontal datum of Egypt, was held fixed in the adjustment stage of this loop.

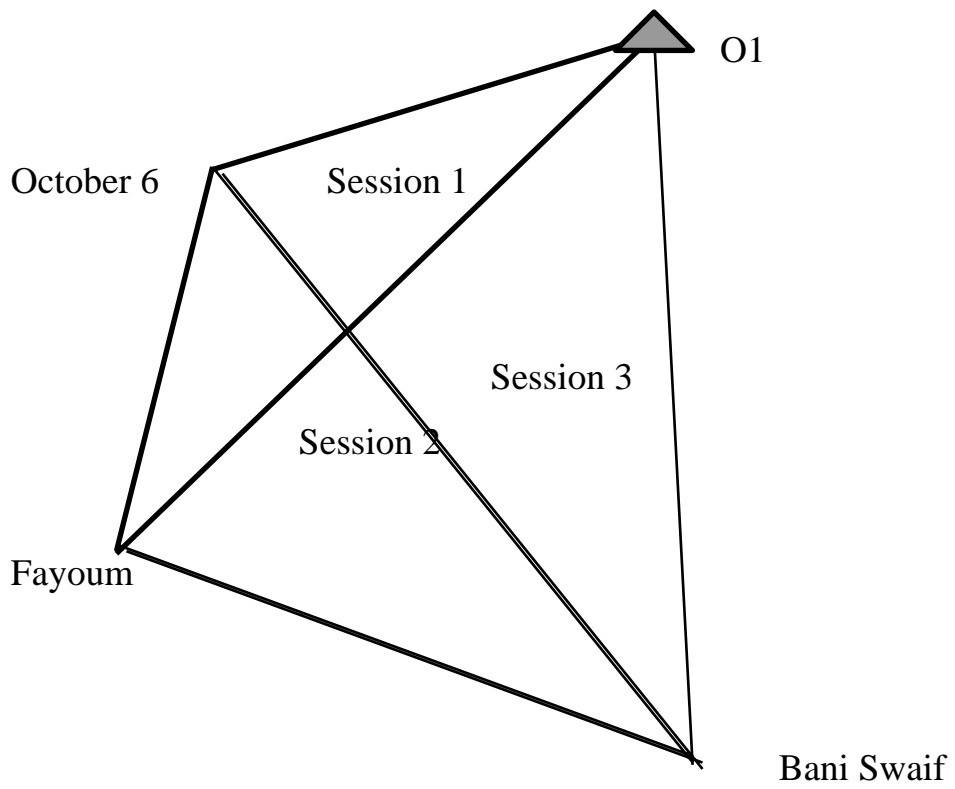

Figure 3-7

An example of GPS Sessions in an ENGSN97 Loop

For post processing GPS measurements, the Gpsurvey software is utilized. It includes a utility to generate information for planning GPS surveys, processes either single or dual frequency GPS phase data, operates in a single-vector mode or simultaneous multi-vector mode for up to ten stations, has an automatic cycle slip fixing module, and performs several statistical tests [Trimble 1997]. The same software is used for the adjustment of GPS processed base lines. It performs least-squares adjustment, coordinates transformation, map projection, and statistical tests.

Another program for GPS Network Adjustment and Detection of Outliers (NADO) developed by the author is frequently used in the adjustment of GPS networks. The input are the three components of each processed GPS vector along with its variance-covariance matrix. The advantage of NADO is that it includes a built-in automatic outlier detector which utilizes the τ (tau) statistical test, section 4-5, to identify outliers in the GPS network. It is concluded that detecting and removing outliers in high-precision GPS geodetic networks could improve the reliability of these networks [Alnagar and Dawod, 1995a]. Typically, an accuracy of 3 cm in the horizontal positions, and 5 cm in the vertical position, are achieved for the GPS coordinates of the ENGSN97 network.

3.6 Precise levelling measurements

The accuracy of height value is considered one of the most important factors in the geodetic observations for processing and reduction of gravimetric quantities. Two types of heights are used in geodetic

applications: (i) the geodetic height, h , relative to the ellipsoid surface, and (ii) the orthometric height, H , relative to the geoid surface (Fig. 2-5).

In each gravity loop in the ENGSN97 project, the orthometric height of each station is determined by the precise levelling technique. Wild N3 precise levels, with a precision of 0.1 mm, and Invar rods are used in levelling routes, each starts from a first-order bench mark. The distance between the Invar rods in two consecutive points was chosen to be 50 meters. The field data recording sheet includes the observer name, the precise level model and serial number, and the atmospheric conditions during observation time. Figure 3-8 depicts an example of the precise levelling scheme in one of the ENGSN97 loop. The specifications of precise levelling are satisfied when judging the levelling observations. That means that the difference between the two directions of an observed levelling line should not exceeds $4\text{mm} \sqrt{K}$, where K is the distance in kilometer.

For precise levelling data, a FORTRAN program (called FRSTLVL) developed by the author is used. It checks the validity of the observations, compute the closure error, and compare this value to the allowable limits of precise levelling to accept or reject the observations of a levelling route.

Having values of both the orthometric and ellipsoidal heights for ENGSN97 network, the geoidal undulations are computed and a GPS-based geoid model is achieved, as will be discussed in details in Chapter 6.

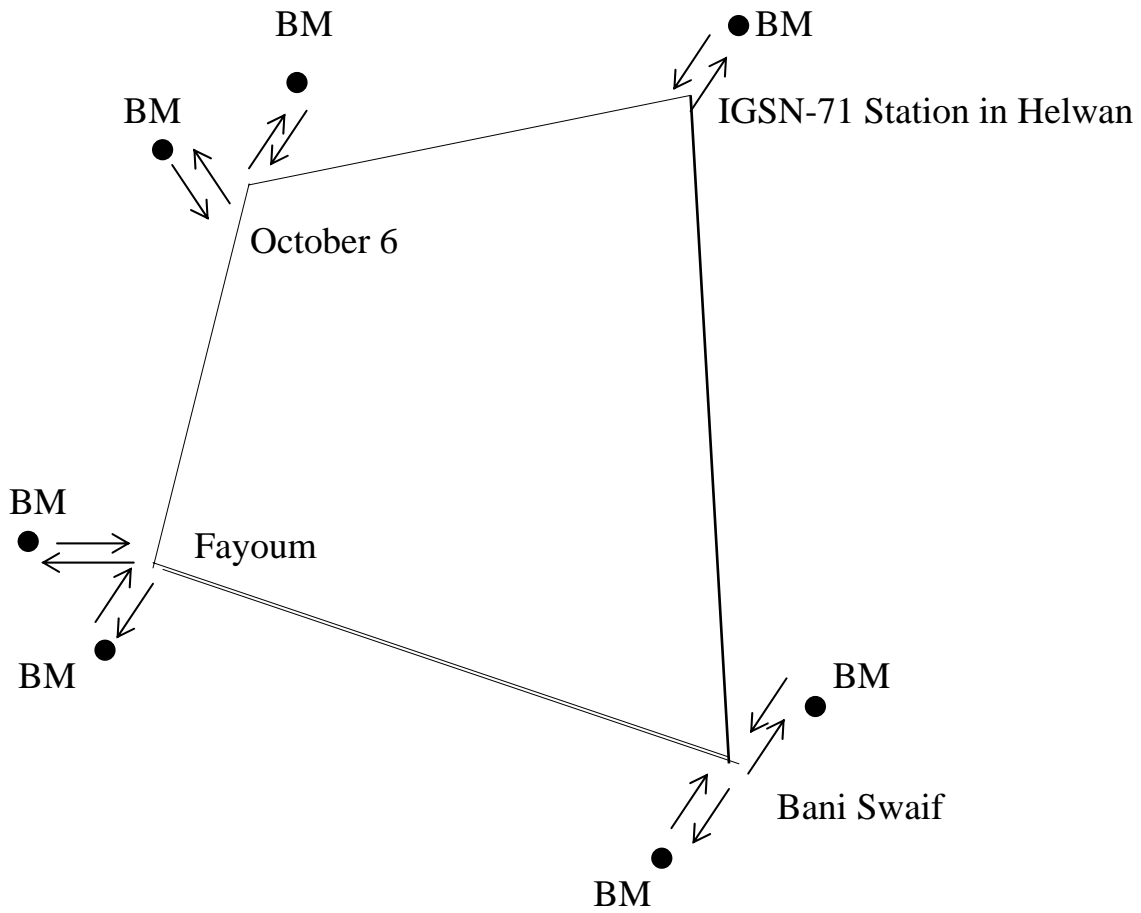

Figure 3-8

An example of the precise levelling in an ENGSN97 Loop

Chapter 4

Development of appropriate models for processing and adjustment of the ENGSN97 gravity data

One of the main objectives of this research study is to design an effective gravity processing model that does not depend on any commercial software. On the other hand, the required model should be general in nature and capable of dealing with all types of gravity measurements in the ENGSN97 network. In other words, such a developed model must accept observations taken along a single or multiple gravity loop, as observed by a single or multiple gravimeter, with or without time breaks during collecting such observations.

In order to achieve the objective of this chapter, the analysis of gravity processing models, used previously in adjusting some selected national and international gravity networks, will be given first. Then, the stipulated criteria for the new proposed model, to be developed here, comprising all different cases of observational schemes, will be presented, according to which the sought processing model will be developed. The least-squares adjustment of the overdetermined developed mathematical model, in the form of observation equations, until a final solution for the involved unknown parameters is obtained, along with their accuracy estimates, will be outlined. Finally, the adopted approach for detecting outlier gravimeter readings, will be discussed.

4.1 Analysis of some previously used gravity processing models

The first stage in the development process is to analyze the different mathematical models applied in some selected previously-established gravity networks in order to discover the merits and disadvantages of each model. The first obvious remark is the difference between models using the dial readings as the observables, for instance as has been used in the processing of the JGSN-90 and one of the IGSN-71 different solutions, and those models using the gravity difference between two stations as the observables, such as has been employed in the NGSBN-77 and two solutions of IGSN-71 networks. In case of using the gravity differences as observables, the existing correlation among them is neglected. For example, when one has observed dial readings d_i , d_j , d_k and have computed $\Delta g_{ij}=d_i-d_j$ and $\Delta g_{jk} = d_j-d_k$, the dial reading d_i has been used in both computations and hence, the correlation between Δg_{ij} and Δg_{jk} is neglected.

In case of using dial readings as the basic observables, one cannot solve for the gravity values without additional observations of other quantities which would give the reference level of the network scales for the gravimeters [Morelli et al, 1971] . This information can be provided by observing at least one absolute gravity station.

It has been proved by statistical tests that, the second and higher orders of the gravimeter scale factor are negligible [Scintrex, 1990; Morelli et al, 1971]. The three individual adjustments of the IGSN-71 (section 2.5.1)

underline the fact that the statistical procedures are crucial to detect any erroneous observations that might affect the overall reliability of the network.

The above results, as concluded from processing of previously-established national and international gravity networks, will be taken here as the basis for developing the more suitable and appropriate processing models for the ENGSN97 network.

This chapter deals with the development process carried out to obtain appropriate gravity data processing and adjustment models for the ENGSN97 network. First, the criteria selected to be applied in the development stage are outlined. Then, the full derivations of the developed models are given, along with the observation equation system and its least-squares solution formulas. Finally, the tau statistical test procedures are presented, since this test has been employed in the adjustment of the ENGSN97 network in order to flag and delete any erroneous observations and increase the reliability of the obtained results.

4.2 Criteria of the presently developed gravity processing models

Some fundamental criteria have been established, prior to start modeling, in order to come up with an efficient and realistic processing model for the gravity data in Egypt. The basic properties of the developed models are the results of analyzing previous national and international gravity networks, and include:

- * The model should serve two functions: processing gravimetric measurements, and perform least square adjustment to come up with the best linear un-biased estimates of the required quantities. This point could be a good advantage of the proposed model since it enables us to estimate simultaneously other parameters more than just the gravity values of the network's stations.

- * The basic observables of the model are just the original dial readings of the gravimeters after converting them to milligal unites and being corrected to tide effects. This criterion is chosen to avoid working with the gravity differences as the model's observables because of two reasons:
 - (1) Several observation schemes have been used in the field work of the ENGSN97 (i-e., the step method , the profile method, .. etc.) and therefore it is difficult to design a model that works with all these field procedures, at the same time.
 - (2) It is a matter of fact that the gravity differences measurements have high correlation between them while the original dial readings do not posses this property, as indicated before.

- * The model should be general enough to accept introducing some systematic errors in the estimation process, to be treated as nuisance unknown parameters. For example, the drift rates and the calibration functions of the different gravity meters could be estimated in this model and their effects on the gravity values are taken into considerations.

- * The developed model should be capable of dealing with absolute gravity measurements as long as the relative gravity measurements (it is so hard to apply this point if the observables are the gravity differences).
- * The model should be compatible with some methods of detecting outliers so that this step being applied as a built-in routine to scan the data and flag any erroneous observations in order to increase the reliability of the estimated parameters.

4.3 The developed observation equation gravity processing models

Some of the selected available, and previously used, gravity processing models, were analyzed in section (4-1). From such analysis, the author has gained some sufficient experience about the advantages and drawbacks of these models, Upon which, the essential criteria for developing new accurate models, have been carefully stipulated in section (4-2). Consequently, the purpose of this section is to introduce the observation equations, for a gravimeter reading, as a function of the involved unknown parameters, for each case of observation that can be encountered in practice, when establishing or densifying a first-order gravity network. Simple models in the developing process have been started with until a general and complex model has been reached. These models include:

- * Processing of a single loop observed by a single gravimeter,
- * Processing of a single loop observed by several gravimeters,
- * Processing of several loops observed by several gravimeters, and
- * Processing of absolute gravity measurements.

The observation equation gravity processing models, pertaining to each one of those listed cases, will be handled in a separate sub-section. The models dealing with relative gravity observations, will be treated first, taking into considerations the different properties and systematic errors associated with the used gravimeter and relative gravity measurements. Then, the corresponding processing models associated with known absolute gravity stations, will be given.

4.3.1 Processing model for a single loop observed by a single gravimeter

For a simple gravity loop, one gravimeter is used starting from a gravity station with known gravity value and proceeds in a specific observation scheme (e.g., step or profile observation method), until the loop is closed on the same known station. Therefore, in such elementary loop scenario it can be assumed that:

- * Only one gravity meter has been used,
- * Only one gravity loop has been observed, and
- * There is no break in the field procedure.

Hence, the following equations could be written:

$$\Delta r_{ij} = g_j - g_i \tag{4-1}$$

where,

Δr_{ij} is the differences in gravimeter readings between stations i and j after converting these readings to milligal units and correct them for the tidal effect.

g_j The gravity value, in milligal, of station j, and

g_i The gravity value, in milligal, of station i (the known station).

At the station i, whose absolute gravity value is known, the following equation may be written:

$$g_i = r_i + O \quad (4-2)$$

where,

O is a quantity describing the orientation of this gravity data. It could be thought of as a shift (in milligal units) between the gravimeter reading and the known gravity value of this station, and

r_i is the gravimeter reading in milligal corrected to the tidal effect.

Substituting equation (4-2) into equation (4-1), one gets:

$$\begin{aligned} \Delta r_{ij} &= g_j - g_i \\ &= g_j - (r_{ii} + O) \\ &= g_j - r_{ii} - O \end{aligned} \quad (4-3)$$

Since,

$$\Delta r_{ij} = r_j - r_i \quad (4-4)$$

where,

r_j is the gravimeter reading of the station j, and
 r_i is the gravimeter reading of the known station i.

Substituting equation (4-4) into equation (4-3), one gets:

$$\begin{aligned} r_j - r_i &= g_j - r_i - O \\ r_j &= g_j - r_i - O + r_i \\ r_j &= g_j - O \end{aligned} \tag{4-5}$$

Adding the effect of the gravity meter drift, equation (4-5) becomes:

$$r_j = g_j - O + \Delta t_{ij} \cdot d \tag{4-6}$$

where,

Δt_{ij} is the difference in time between the running station j and the initial fixed station i, and

d is the drift of the used gravity meter (assuming linear function).

Equation (4-6) is the basic equation describing the mathematical relationship between the gravimeter readings of a gravity meter, as observables, and the gravity values of the observed stations, taking the systematic drift error of the gravity meter, as well as the unknown gravity orientation parameter at the fixed station i, into considerations. Every gravimeter reading on any station in the observed gravity loop gives one equation of the form of (4-6).

Note that, in the above observation equation (4-6), the only observed quantity is the gravimeter reading, r_j , whereas the unknown parameters will be three quantities, g_j , O , and d . In other words, for " n " observed gravity stations, there will be " n " observation equations of the type (4-6), and the number of unknowns will be two plus the number of unknown gravity stations. Therefore, if " n " equals the number of unknowns, there will be one solution only for the system of observation equations. However, this is not the case in practice, where there should be as many redundant observations as possible. In such a case, one will be faced with an overdetermined mathematical model, whose solution becomes possible on the basis of least-squares principle, as will be presented later.

4.3.2 Processing model for a single loop observed by several gravimeters

In this case, we try to include more than one gravity meter in the model keeping all other simple assumptions. This means that two gravity orientation unknowns (one for each gravimeter) will be introduced. Therefore, the corresponding observation equation model is extended and read as follows:

$$r_{jk} = g_j - O_k + \Delta t_{i,j,k} \cdot d_k \quad (4-7)$$

where,

k is the gravity meter number,

r_{jk} is the reading of the k^{th} gravity meter on station j ,

$\Delta t_{i,j,k}$ is the difference in time between the running station j and the initial fixed station i , using the k^{th} gravity meter,

d_k is the drift of the k^{th} gravity meter, and the remaining symbols are the same as defined before.

In this case, there will be " n " observation equations of the type (4-7), where the number of unknown parameters will be equal to the number of unknown gravity stations " j ", and twice the number of the used gravity meters " k " .

4.3.3 Processing model for several virtual gravimeters (with occurred time break) in a single loop

If there is a break in the observation campaign with the same gravimeter, the drift of the gravity meter in this period of time break should be zero, i.e., the data set is divided into two subsets. Therefore, another drift and gravity orientation unknowns are introduced in the model and should be estimated. Hence, for each actual gravimeter there will be two sets of parameters to be estimated for two situations: before and after the break. Each set is composed of the two gravity orientation parameter and the gravimeter drift parameter. Two new term called " virtual gravimeter " and " virtual loop " are introduced to distinguish between these two situations. To handle this case, the observation equation model should be extended to be:

$$r_{jkl} = g_j - O_{k,l} + \Delta t_{i,j,k,l} \cdot d_{k,l} \quad (4-8)$$

where,

l is the data series number, which defines the input data for the observed part of the same loop, before and after the occurred break,

$r_{j,k,l}$ is the reading of the k^{th} gravity meter on station j in the l^{th} data series,

$\Delta t_{i,j,k,l}$ is the difference in time between the running station j and the initial fixed station i , using the k^{th} gravity meter in the l^{th} data series,

$d_{k,l}$ is the drift of the k^{th} gravity meter in the l^{th} data series, and the remaining symbols are the same as defined before.

For “ n “ observation equations of the form (4-8), there will be a number of unknowns equals to the number of the unknown gravity stations, in addition to double the number of the used gravimeters, and the number of the occurred breaks.

4.3.4 General processing model for several loops observed by several gravimeters

In this step, a calibration function is introduced for each used instrument so that the model estimate the functions coefficients. It is good enough to assume a linear calibration function for recent LaCoste and Romberge gravity meters. Hence, the observation equations model will be:

$$r_{j,k,l} = g_j - O_{k,l} + Z_{j,l,k} \cdot e_{k,l} + \Delta t_{i,j,k,l} \cdot d_{k,l} \quad (4-9)$$

where,

$Z_{j,k,l}$ is the original dial reading (in counter units) of this observation j in the l^{th} data series using the k^{th} gravimeter, and $e_{k,l}$ is the unknown error in the used linear calibration coefficient for the k^{th} gravimeter, that was used in transforming the dial reading in counter units into the equivalent mGal units, as estimated from the gravimeter readings on gravity stations with known absolute values.

In addition, the symbol “ l ” in equation (4-9) represents either the data set number before and after each break in the same loop, or indicates the data set number for each added new observed loop. By this way, one can expect more accurate estimation for all the unknown parameters, especially the gravity values at the unknown gravity stations.

4.3.5 Processing model for absolute gravity measurements:

An observation equation for absolute gravity observations at some station of the gravity network could be incorporated into the developed model to process and adjust the network within the absolute gravity reference system. The corresponding observation equation model takes the form of:

$$r_{j,k,l}(\text{abs}) = g_j(\text{abs}) - O_{k,l} + Z_{j,l,k} \cdot e_{k,l} + \Delta t_{i,j,k,l} \cdot d_{k,l} \quad (4-10)$$

where,

$r_{j,k,l}(\text{abs})$ is the reading of the k^{th} gravity meter on the absolute gravity station j in the l^{th} data series using the k^{th} gravimeter, and

g_j (abs) is the known absolute gravity value of station j.

Of course, there will be a number of observation equations of the type (4-10), equals to the number of known absolute gravity stations in the network. It is worthwhile to mention here that, there are other ways of treating the known absolute gravity values at some stations of the network, which will be outlined in the next section

4.4 The least-squares adjustment of the developed observation equations models

Recall from the previous section that the developed observation equations for gravity processing, expressed by equations (4-7), (4-8), (4-9), and (4-10), have been written as one observation equation for each dial reading of the used gravimeter, for both simple and complex cases of observations. In addition, it has been stated that there are many reading observation as possible, for obtaining the best estimated values of the involved unknown parameters (e.g. gravimeter drift, gravimeter calibration coefficient, gravity orientation unknown ... etc.). However, since the gravimeter readings are not perfect (true), due to several factors, like for instance, the skill of the observer, electronic components of the gravimeters, the atmospheric and transportation circumstances, ... etc., the above mentioned observation equations do not lead to the same unique solution, unless those gravimeter readings are assumed to contain certain random errors (residual errors), which must be estimated and corrected for. This can be

achieved in practice by applying the least-squares principle to those observation equations, which read:

$$V^T P V = \min \quad (4-11)$$

where,

V is the $n \times 1$ residual vector, or corrections to the observed gravimeter readings, in which n is the total number of those readings,

P is the so-called weight matrix of the observed gravimeter readings, with dimension $n \times n$, which can be expressed as [e.g. Nassar, 1981]:

$$P = \sigma_o^2 \Sigma_L^{-1} \quad (4-12)$$

where,

σ_o^2 is called the apriori variance factor, which can be considered here as a scalar quantity that makes Σ_L^{-1} matrix to be well-conditioned for inversion process, and hence, can be chosen arbitrarily, say a unity for simplicity, and

Σ_L^{-1} is the variance-covariance of the observed gravimeter readings, which can be safely taken here as a diagonal matrix, whose diagonal elements are the variances of the gravimeter readings, since all gravimeter readings dealt with here are uncorelated differences of gravimeter readings between successive stations. Moreover, if one considers all gravimeter readings taken over the gravity network under consideration to be with the same precision, that is the same variance, the apriori variance factor σ_o^2 can be taken as assigned variance of observations, leaving the variance-covariance matrix Σ_L simply as a unite matrix.

Since equation (4-9) represents the general processing observation equation as a gravity processing model, which includes all kinds of gravity and operational systematic errors treated as unknown parameters, it will be elaborated-on here. For the remaining developed observation equations, pertaining to more simpler cases of observations, they will be just special cases of the general form (4-9). In this case, the observation equation (4-9), relating both adjusted gravimeter readings and unknown parameters, will take the following form:

$$r_{j,k,l} + Vr_{j,k,l} = g_j - O_{k,l} + Z_{j,l,k} \cdot e_{k,l} + \Delta t_{i,j,k,l} \cdot d_{k,l} \quad (4-13)$$

which can be re-arranged and written as a residual equation, that is:

$$Vr_{j,k,l} = g_j - O_{k,l} + Z_{j,l,k} \cdot e_{k,l} + \Delta t_{i,j,k,l} \cdot d_{k,l} - r_{j,k,l} \quad (4-14)$$

For simple handling of the overdetermined observation equations, given by (4-14), in both mathematical treatment and computer programming, it is a usual practice to use matrix notation. In other words, equation (4-14) can be written in the following linear matrix form:

$$V_{n,l} = A_{n,n} X_{u,l} - L_{n,l} \quad (4-15)$$

where,

$V_{n,l}$ is the vector of residuals defined before,

$X_{n,1}$ is the vector of "u" unknown parameters (including the gravity values g 's at the unknown gravity stations as the main parameters; the gravity orientation unknowns O 's, gravimeter drift coefficients d 's, and gravimeter calibration coefficients e 's, as the associated nuisance parameters).

$A_{n,u}$ is the matrix of coefficients of the unknown parameters, in the linear residual equation, and

$L_{n,1}$ is the vector of observed gravimeter readings.

It should be noted in equation (4-15) that, both vectors X and V are unknowns, while both the coefficient matrix A and the vector L of absolute term of the linear residuals equations are known before adjustment. From the above discussions of the least-squares principle, equation (4-11), the weight matrix of the observed gravimeter readings must be established before the adjustment also. This means that both X and V vectors are required to be estimated through the least-squares process. Sometimes, one can refer to the vector of unknown parameters X as the solution vector, for which the corresponding normal equation must be formulated basically. Also, since both A and P matrices, as well as the vector L , must be known before entering the adjustment process, they usually referred to them as the designed matrices.

Going back to equation (4-15), as applied to our case here of adjusting gravity networks, one can illustrate the involved vectors and matrices, by taking a simple example. Assume that we have three loops required to be simultaneously adjusted, in which the first loop has one time break in the observations and contains four stations, where station number one is fixed,

while the break occurs after observing the third station, with a total of 6 readings before the break and 6 readings after the break. The second loop contains 3 new stations starting from station number three of the first loop, with a total of 16 readings, and the third loop includes 2 new stations and starts from station number 6 in loop 2. Moreover, the first loop and the third loop were measured using the same gravimeter, while the second loop was measured by two different gravimeters, one of them is the same gravimeter used for the other two loops. In this case, one gets the following:

- $i = 1$ Number of fixed station,
- $j = 8$ Total number unknown gravity values,
- $k = 2$ Total number of the used gravimeters,
- $l = 5$ Number of involved data sets,
- $n = 34$ Total number of observations, and
- $u = 20$ Total number of unknown parameters.

Based on the above assumptions, both vectors V and L will take the following forms:

$$V = [V_{1,1,1} \dots V_{6,1,1} V_{7,1,2} \dots V_{12,1,2} V_{13,1,3} \dots V_{20,1,3} V_{21,2,4} \dots V_{28,2,4} V_{29,1,5} \dots V_{34,1,5}]^T$$

$$L = [r_{1,1,1} \dots r_{6,1,1} r_{7,1,2} \dots r_{12,1,2} r_{13,1,3} \dots r_{20,1,3} r_{21,2,4} \dots r_{28,2,4} r_{29,1,5} \dots r_{34,1,5}]^T$$

Similarly, vector X of unknown parameters takes the following form:

$$X = [g_2 \dots g_9 O_{1,1} O_{1,2} O_{1,3} O_{2,4} O_{1,5} d_{1,1} d_{1,2} d_{1,3} d_{2,4} d_{1,5} e_1 e_2]^T$$

As far as the coefficients matrix A , it will take the dimension of 34×20 , in which its elements on each row will contain the following:

- 1 for every unknown gravity station,
- 1 for each gravimeter with each set of data series or virtual loops,
- $\Delta t_{j,k,l}$ time difference in hours between the initial first station and each gravimeter reading at unknown station, for every gravimeter, for the appropriate data set, and
- $Z_{j,k,l}$ gravimeter readings, in dial counter units, as read on each station.

Applying the least-squares principle (equation 4-11) to the linear mathematical model of the residual equation (equation 4-15), the following normal equations system, can be generated for the vector X of unknown parameters as [Uotila, 1986]:

$$(A^T P A)_{u,u} X_{u,1} = (A^T P L)_{u,1} \quad (4-16)$$

which can be re-written in the following abbreviated form:

$$N_{u,u} X_{u,1} = U_{u,1} \quad (4-17)$$

where $N = A^T P A$; and $U = A^T P L$.

The solution of equation (4-17) for X will be:

$$X^{\wedge} = N^{-1} \cdot U \quad (4-18)$$

Note that the solution vector will X^{\wedge} will directly give the estimated values of the involved unknown parameters, since the observation equations

models (4-19) are already linear and hence, there was no need to start with approximate values for the unknown parameters. Instead, the double precision is used for all kinds of associated computations.

The covariance matrix of the estimated unknown vector is denoted here by Σ_x^\wedge , which can be obtained through ordinary propagation of covariance matrices, and yields:

$$\Sigma_x^\wedge = \sigma_o^{\wedge 2} N^{-1} \quad (4-19)$$

where,

$\sigma_o^{\wedge 2}$ is the aposteriori variance factor, considered as unbiased estimator for the previous assumed apriori variance factor σ_o^2 , and is given by:

$$\sigma_o^{\wedge 2} = (V^T P V) / (n-m) \quad (4-20)$$

In some cases, for subsequent analysis of gravimeter readings, one can further obtain the adjusted readings as:

$$L^\wedge = L + V^\wedge \quad (4-21)$$

whose corresponding estimated covariance matrix can be found to be:

$$\Sigma_L^\wedge = \sigma_o^{\wedge 2} A N^{-1} A^T \quad (4-22)$$

From the discussions given in the previous section concerning the treatment of the fixed absolute gravity values at some stations of the gravity network under adjustment, there are usually two approaches for such a treatment. Both approaches have the same objective, which is keeping the final established gravity values at those stations to be fixed at their known absolute values, without any sort of corrections or alteration after completing the adjustment process.

The first approach is to add some constraints on the final values of gravity as estimated from the adjustment. Such an approach is sometime called conditions of some unknown parameters, which in our case here takes the following form at each absolute station:

$$g_j \text{ (estimated)} = g_j \text{ (known absolute)} \quad (4-23)$$

This last condition can be written with matrix notation as:

$$G(X) = 0$$

Such constraints, when written in the form of residual equation as equation (4-15), can be added to the model (4-15), and both models are combined into the same least-squares adjustment process.

The second approach is based on having pre-information of some of the unknown parameters, which in our case here, will be basically the known absolute gravity values at some stations in the network, which are desired not

to be considered as completely errorless quantities. In other words, those known absolute values are given from, say, previous world-wide adjustment with their appropriate estimated variances. In this case, those known absolute gravity values, can be considered in the adjustment process as pseudo-observations, instead of dealing with them as pure unknowns or as providing some constraints or conditions for their corresponding parameters. Again, those pseudo-observations can be formulated as residual equations, similar to equation (4-15), while the residual equations for both the original gravimeter readings and pseudo-observations can be combined together into the same adjustment process.

If one desires to keep the known absolute gravity values at fixed or errorless values, the second approach can be applied by assigning a very small value for the variance of each pseudo-observation absolute gravity station, which means a very large value for their assigned weights before adjustment. Theoretically, this variance should be taken as a zero value. However, for computational conditioning, it must be taken a non-zero value close to zero as the stability for inversion process is satisfied with the employed double precision. In such a case, the estimated absolute gravity values will be unchanged for their corresponding known absolute values. Here, the second approach is usually known as the least-squares adjustment with weighted parameters. Details regarding the mathematical formulation of the above two approaches can be found in the appropriate literature dealing with the subject matter [e.g. Mikhail 1976 and Uotila 1986].

However, from the practical treatment point of view, especially when using digital computers, the second approach can be applied in a more simpler fashion, without any set of pseudo-observation equations characterizing the weighted gravity values parameters at the absolute stations. This can be done by adding a relatively high weight to the diagonal elements of the normal-equation matrix N (equation 4-17) that correspond to each absolute gravity station. It should be stressed here, that all absolute gravity stations should be considered among the unknown gravity stations. In fact, this last treatment of the second approach, is the one used in the present research for adjusting the involved gravity data taken along the ENGSN97 network.

4-5 Detection of outliers

A great deal of research has been carried out in past years on the development of statistical and numerical techniques to detect outliers in precise engineering measurements.

Gross errors may be defined as the results of a malfunctioning of either the instrument, or the observer. It is naturally expected that outliers are caused by gross errors. But, what is an outlier?. Caspary [1987] defines an outlier as "a residual which, according to some test rule, is in contradiction to assumptions on the stochastic properties of the residuals". Therefore, the detection of outliers depends on the selected risk level, the assumed distribution, and the test procedure.

Generally, the methods used in identifying outliers may be grouped according to two basic concepts of modeling the outliers [Chen et al, 1987]:

- (i) outliers have a mean shift model with the normal distribution of $N(\mu+\delta, \sigma^2)$ instead of $N(\mu, \sigma^2)$ where μ is the expected mean, σ^2 is the variance, and δ is the mean shift value.
- (ii) outliers come from a variance inflation model with the normal distribution of $N(\mu, a^2 \sigma^2)$ where $a^2 > 1$.

Barada [1968] followed the first concept and developed the so-called data-snooping method under the assumption that the a priori standard error of unit weight (σ_o) is known. Pope [1971] presents another test strategy considering σ_o to be unknown in practice, but its a posterior estimate ($\hat{\sigma}_o$) is available. Pope's method has been used in the present study in detecting outliers in the ENGSN97 gravity data.

Instead of using the residual (v_i) for each observation, another quantity, T_i , which is the normalized or standardized value of v_i can be used, that is defined as:

$$T_i = \frac{|v_i|}{\sigma_v} \sim \tau(f) \tag{4-24}$$

is used as the test statistics of the i^{th} observation using the τ (tau) distribution with f degrees of freedom.

Pope [1976] provides an algorithm which computes the critical τ value with the corresponding tables of the τ distribution. Although the τ distribution is used in geodetic applications, it is not found in statistical literature. However, it should be stated that the τ distribution can be transformed from the known Student's t-distribution.

The null hypothesis, H_o , of the τ -test assumes that all observations are normally distributed with $E(L) = AX$, so that the expectation of the residuals is zero:

$$H_o : E(V_i) = 0 \quad (4-25)$$

The alternative hypothesis, H_a , is:

$$H_a : E(V_i) \neq 0 \text{ for one residual.} \quad (4-26)$$

H_o is rejected for a residual V_i , if $T_i > \tau_{\alpha, f}$ for a certain type I error percentile (α).

Traditionally, an observation is considered to be an outlier, and hence, rejected, if its own estimated residual was greater than a certain multiple of the standard deviation of the residual PDF (Probability Distribution Function). This was based on the assumption that the original observations were having equal weights, and the commonly used multiple factor was 3, which corresponds to 99.7% probability level. However, using the normalized

residual, into the so-called tau test, implies that each residual is treated with its own standard deviation, which may generally differ from one observation to another. Accordingly, it can be said that the use of normalized residuals is much more meaningful than the use of the residuals themselves. If a residual (even with small magnitude) is much larger than its standard deviation, then it is likely that the corresponding observation is an outlier.

Significant consideration has been given to the detection of outliers in the field of precise surveys. The τ -test, among other statistical tests, offers statistical tools used to identify those erroneous observations that may be contaminated by gross errors [Alnaggar and Dawod, 1995].

From the above methodology, it is clear that, for applying the tau test on the estimated residuals of the gravimeter readings in our case, one needs the estimated standard deviations of the estimated residuals, besides the residuals themselves (V). This can be obtained simply, by taking the square roots of the diagonal elements of the covariance matrix of the residuals $\hat{\Sigma}_V$. After the adjustment, the vector \hat{V} of estimated residuals can be obtained by substituting equation (4-18) into equation (4-15) to get:

$$\hat{V} = [A N^{-1} A^T P - I] L \quad (4-27)$$

Applying the law of propagation of covariance matrices [e.g. Nassar, 1984] on equation (4-23), the estimated covariance of the estimated residuals can be found to be:

$$\hat{\Sigma}_V = \hat{\sigma}_o^2 [A N^{-1} A^T - P^{-1}] \quad (4-28)$$

Usually, for the purpose of applying the tau test, one does not need to store the full covariance matrix of the estimated residuals, instead the vector of the diagonal elements expressing the residual variances is stored only in the computer memory. This will certainly save much effort and time of handling such a test, and can be easily done in practice through appropriate computer programming algorithms. It goes without saying that, if some of the gravimeter readings are required to be rejected, the least-squares solution procedure, as outlined in the previous section, taking into considerations the remaining readings after the rejection process into account only, must be repeated, and the tau test is applied again, until all the data is filtered out.

Chapter 5

Data processing and analysis of results of the ENGSN97 gravity network

The main requirements for establishing and observing the ENGSN97 gravity network, have been presented in chapter 3. In addition, the completed observation equations, including all significant error budget associated with the adopted methodologies and instrumentation, have been formulated in chapter 4, along with the adopted techniques of adjustment and post analysis of the obtained results. This chapter, however, is devoted to the data processing of the ENGSN97 network, including the highlight of the developed computer programs, needed for all involved computations, as well as performing different solutions, for investigating all effecting factors on the final results, one at a time. The collected data for the ENGSN97 gravity network, according to its adopted configurations, techniques of observations, and available types of gravimeters, will be given first. Then, the developed computer software, for processing single or multi loops, observed with one or more gravimeters, with or without time breaks during observations, until the recovery of the entire network, will be outlined. In addition, six different solutions of the entire network, which ended up with the best solution taken all influence factors into account. The final solution of the ENGSN97 network will be achieved, after removing all existing outlier gravimeter readings from the last solution number six. For this final solution, the gravity variations at some locations over the Egyptian territory, over a period of more than twenty years, will be investigated by comparing their gravity values, with the

corresponding ones from old international and national gravity networks. Finally, the essential characteristics of the final solution of the ENGSN97 network, as considered to be the best possible optimum solution that can be currently obtained, will be summarized, along with the obtained gravity anomalies maps for Egypt, based on the final results of that best solution. Each one of these items will be manipulated below in a separate section.

5.1 The ENGSN97 gravity data

The entire ENGSN97 network has been dealt with. The configurations of this network was given before in figure (3-1). It consists of 145 relative gravity stations and five new absolute gravity stations established in Egypt in 1997. The network has been observed through 51 loops as shown in Fig (5-1). The minimum, maximum, and average distance spacing between stations are 0.136, 128.144, and 65.988 Km respectively. Seven LaCoste and Romberge relative gravimeters have been utilized in the observation campaigns of ENGSN97 network. The step method and the profile method have been used as observation scenarios (section 2-4). Table 5-1 presents a summary of the ENGSN97 input statistics.

Each data series (i.e., a loop as observed by a single gravimeter) was analyzed in several steps before carrying out the overall adjustment. The first check is the validity of the field observations. A valid station observation consists of three consecutive nulls that agree to 0.01 counter dial unit observed within five minutes at the most. The average of the three nulls is then used as a unique observation in the data series.

Table 5-1

The ENGSN97 input data

Number of Stations	150
Number of Observations	1085
Number of Loops	51
Number of Gravimeters	7
Minimum Station Separation	0.136 Km
Maximum Station Separation	128.144 Km
Average Station Separation	65.988 Km

The gravimeter reading is converted to corresponding milligal values by using the calibration table of each gravimeter provided by the manufacture. It is worth mentioning that there were no trustable absolute gravity stations still existing in Egypt before 1997 to perform field calibration of the gravimeters. However, two alternatives were executed through the establishment of the ENGSN97: (1) performing the known three field checks (permanent adjustment) of each gravimeter prior to each loop to insure the performance of the gravimeters, as stated in section 3-4; and (2) sending the gravimeters to the manufacturers to perform both field and laboratory calibrations.

The solar-plus-linear tide correction, subtracted from the observations, are computed based on the formula of Longman except that the values are increased by 16% to compensate for the finite deformation or compliance of the Earth [LaCoste and Romberge, 1989b]. The GRAVPAC software was used to perform these two steps and produces the so-called metered-gravity values which become the basic observables, given on the left-hand side of the generalized gravity processing model (4-10), along with its special cases, and

hence, constitute the main observables to be input to the developed processing programs.

Two different observation scenarios are applied in the field campaigns in this network: the step method; and the profile method, as mentioned before. Both of them give precise results regarding the drift control. However, the step method is economically expensive since it requires three stops over every station while in the profile method only two stops per stations are needed. Recall from section (2-4) that, the original scenario of the profile observation scheme is observing the station sequence as 1-2-3-4-4-3-2-1. Tacking the time break after the first observation over station 4 will divide the loop into two parts: 1-2-3-4 and 4-3-2-1. Both of the new data series does not have any repeated observations, which make the drift estimation is impractical. Two alternatives are proposed:

- (1) If the loop observation time is relatively short, there is no need for the break and the observation scenario should be modified to be: 1-2-3-4-5-4-3-2-1, where station 5 is any arbitrary station not of interest. This station is observed just to separate the two consecutive observations over the network station 4 and to avoid having gravimeter dial remain fixed.
- (2) In case of a long observation time of the loop, the observation scenario should be: 1-2-3-4-4-break-4-4-3-2-1.

5.2 The developed computer programs for processing the ENGSN97 gravity data

The efficient newly-developed processing models, presented in section 4-3, have been utilized. Several LF90-language computer programs have been developed by the author to process, adjust, and analyze gravity networks in several stages as:

- * Processing each single loop using a single gravimeter at a time,
- * Processing each single loop using several gravimeters combined together,
- * Processing and adjustment the entire ENGSN97 network, and
- * Outlier detection within final adjustment of the ENGSN97.

The first two stages of the above list will be handled here in separate subsections. However, the remaining two stages, pertaining to the entire network, will be presented in another sub-section.

5.2.1 Primary analysis of each loop using one gravimeter at a time

The first program processes data of one loop conducted by one gravimeter utilizing equation (4-6). The objective of this program is to analyze each gravimeter's observation separately to investigate the quality and the performance of each gravimeter in a loop. The developed observation equation model of the least-squares adjustment technique (section 4-4) is applied.

The basic observables of this program are the original dial reading of the gravity meter after converting them from the gravimeter's dial units to

millgal unites and being corrected to tide effects. Therefore it can handle a loop that has been observed by any observation schemes (e.g. the step method or the profile method). The unknown parameters here to be estimated are the stations gravity values, g , a gravity orientation unknown , O , and a linear drift unknown, d , of that gravity meter, as defined in equation (4-6). The data input of this developed program include:

- * the gravimeter dial readings (in mGal units),
- * the corresponding time of observations (in hours),
- * the apriori variance factor to be used in the measurement weighting process,
- * the absolute gravity value of at least one station to be held fixed in the adjustment, and
- * an alphabetic stations names and gravimeters numbers to be tabulated in the output.

The program output contain:

- * the estimated gravity value for each gravity station along with its estimated standard deviation,
- * the estimated aposteriori variance factor,
- * the estimated gravimeter drift coefficient with its estimated standard deviation, and
- * the estimated gravity orientation parameter with its estimated standard deviation.

As an example, a specific loop (Fig. 5-2) will be discussed in this section. This loop is of special interest since it relates the old IGSN-71 station (Cairo-B) to the new absolute gravity datum of Egypt. The original field data

of this loop consists of 9 observations for each of the seven gravimeters over 3 stations forming this loop: The absolute gravity station SRI5, the first-order triangulation station O1, and the Cairo-B station. Station O1 was observed as an excenter of the absolute gravity station SRI5. In order to investigate the internal reliability of each loop, a fixed gravity value of zero mGal is assigned to station SRI5. Therefore the unknowns are the gravity values of O1 and Cairo-B stations along with the orientation and the drift of each gravimeter. Table 5-2 presents a part of the results for the seven gravimeters, as processed individually.

Although the results of each data set (the loop as observed by a single gravimeter) seems to be consistent, the performance of the two gravimeters 3 and 6 should be suspected. The gravimeter No. 3 has a relatively high drift coefficient and the gravity value of station Cairo-B as obtained from the gravimeter No. 6 is far away from the mean value of the other six instruments. This finding leads to the need for further investigation of the data from all gravimeters together in one package.

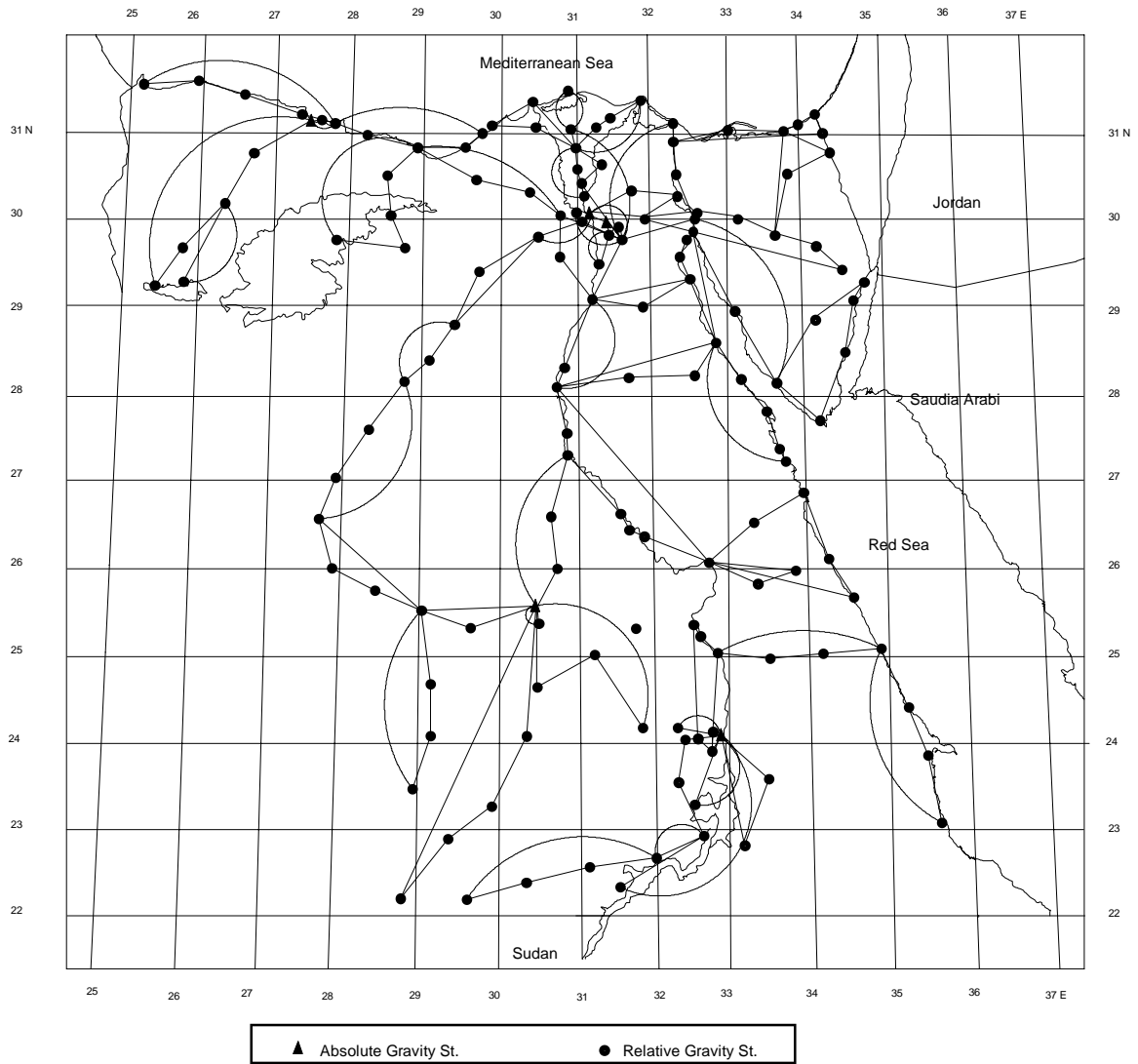

Fig. 5-1

ENGSN97 Gravity Loops Used

Table 5-2

The Processing Results of Loop 1

Gravimeter	Adjusted Gravity of Cairo-B (mGal)	Adjusted Drift Value (mGal/hour)	Maximum Residual (mGal)
1	2.336 ± 0.003	0.001 ± 0.001	-0.005
2	2.341 ± 0.002	0.003 ± 0.001	0.004
3	2.291 ± 0.029	0.050 ± 0.011	-0.025
4	2.367 ± 0.020	0.009 ± 0.008	0.027
5	2.327 ± 0.025	0.017 ± 0.009	0.037
6	2.045 ± 0.021	0.007 ± 0.008	-0.034
7	2.340 ± 0.015	0.014 ± 0.006	0.021

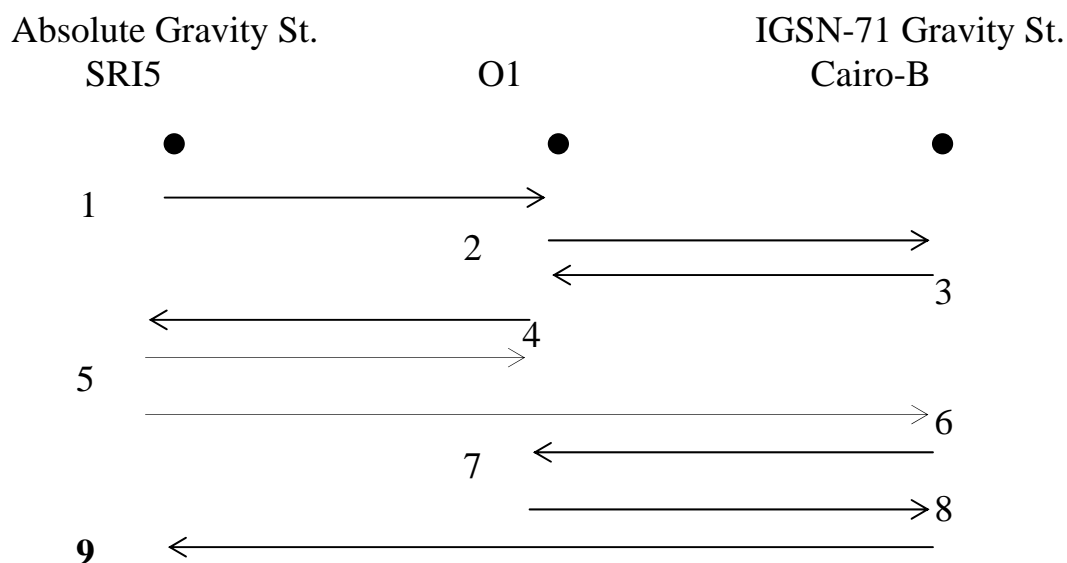

Figure 5-2

The ENGSN97 Gravity Loop No. 1

5.2.2 Analysis of each loop using different gravimeters combined together

The second developed program handles the gravity data of all gravimeters used in observing a loop. Therefore, the unknowns to be estimated are the gravity values of all stations beside a gravity orientation and a drift unknowns for each virtual gravimeter. This program has a built-in outlier detection subroutine used to flag the erroneous observations based on the results of the τ statistical test (section 4-5). The data input of this developed program include:

- * the virtual gravimeter dial readings (in mGal units), i.e., a change in the gravimeter number means either an occurred drift or a new gravimeter data will be followed,
- * the corresponding time of observations (in hours),
- * the apriori variance factor to be used in the measurement weighting process,
- * the absolute gravity value of at least one station to be held fixed in the adjustment, and
- * an alphabetic stations names and virtual gravimeters numbers to be tabulated in the output.

The program output contain:

- * the estimated gravity value for each gravity station along with its estimated standard deviation,
- * the estimated aposteriori variance factor,
- * the estimated drift coefficient for each virtual gravimeter with its estimated standard deviation,

- * the estimated gravity orientation parameter for each virtual data series with its estimated standard deviation,
- * the estimated residuals with their estimated standard deviation.
- * the critical tau value corresponding to the computed degrees of freedom,
- * the normalized residuals, and
- * A list of the flagged outliers.

When dealing with gross-error detection, it was decided to delete only the observation that had the largest normalized residual. Most of the literature dealing with outlier detection stressed that any algorithm should not be used as a black box which automatically cleans the observations. This warning may be explained when we remember the original two assumptions behind the τ -test for outlier detection [Chen et al, 1987]: (1) all observations are normally distributed; and more important (2) only one outlier is assumed to be present in the data set, at a time. Consequently, the whole theory breaks down if the observations include two or more gross errors.

The following rational approach is followed in order to obtain as much correct results as possible [Alnaggar and Dawod, 1995a]:

- * Initial adjustment is carried out using all observations.
- * If more than one normalized residual exceed the critical τ value, only the observation with the largest normalized residual is deleted.
- * The adjustment is repeated again with $n-1$ observations leading to new residuals and new σ_o^2
- * This process is repeated until all outliers are flagged.

Applying this methodology using the data of loop 1, several adjustments were carried out. From the first run, the data of the gravimeter No. 6 show inconsistency with the other gravimeters' observations. Residuals of this gravimeter's observations were as much as 0.172 mGal with higher standard deviation values. Removing the observations of this gravimeter has enhanced the overall adjustment process. As an example, the standard deviation of the adjusted gravity value of station Cairo-B has dropped from 0.016 to 0.007 mGal.

5.2.3 The processing of the entire ENGSN97 gravity network

The third developed computer program, GNPA: Gravity Network Processing and Adjustment, is the main computational tool used in this research study. It processes and adjusts a gravity network that consists of several field loops observed by several gravimeters using the newly-developed model of equation (4-9).

The unknowns contain the gravity values of observed stations and two unknowns (orientation and drift) for each “ virtual instrument ”. If a loop contains a break, its data set is further divided into two virtual data series and two unknowns have to be estimated to each data series. This situation resembles the case as if two different “ virtual instruments “ have been used in this loop. Regarding the gravimeter drift estimation, this implies the fact that during the break time a zero static drift is assigned and two different dynamic drift coefficients are to be estimated for the two data series.

In order to enhance the performance and speed of this program, several programming optimization methodologies are applied [Shaker, 1982]:

- (1) The program detects the number of observations, and gravimeters in the same time of reading the input file.
- (2) A procedure is used to develop the non-zero elements of the corresponding row of the coefficients matrix (A) and write them to a scratch file.
- (3) There is no need to store the coefficients matrix ($A_{n,u}$) or the absolute-term vector (L_n) .
- (4) The normal-equation matrix ($N=A^T P A$) is computed through the accumulation of the contribution of each observation.

These modifications decrease the required computer memory by more than 50% which can enable the use of this program to handle large gravity network on a personal computer (PC) platform. A flow chart of this program is depicted in Fig. 5-3. The data input of this developed program include:

- * the virtual gravimeter dial readings (in mGal units), i.e., a change in the gravimeter number means either an occurred drift or a new gravimeter data will be followed,
- * the corresponding time of observations (in hours),
- * the apriori variance factor to be used in the measurement weighting process,
- * the absolute gravity value of at least one station to be held fixed in the adjustment, and
- * an alphabetic stations names and virtual gravimeters numbers to be tabulated in the output.

The program output contain:

- * the estimated gravity value for each gravity station along with its estimated standard deviation,
- * the estimated aposteriori variance factor,
- * the estimated drift coefficient for each virtual gravimeter with its estimated standard deviation,
- * the estimated gravity orientation parameter for each virtual data series with its estimated standard deviation,
- * the estimated residuals with their estimated standard deviation.
- * the critical tau value corresponding to the computed degrees of freedom,
- * the normalized residuals, and
- * A list of the flagged outliers.

5.2-4 Assessment of the developed program GNPA

A comparison has been carried out between the results of the developed GNPA program and the GRCOMP program, for the purpose of checking and assessment of the performance of the former one. The GRCOMP is a program developed by the U.S. Defense Mapping Agency (DMA) for processing field gravity data. Although GRCOMP can use gravity observations from different gravimeters in a loop, it processes the data from each instrument separately [Stizza, 1997]. GRCOMP starts with the dial readings of the gravimeters, applies the Earth tide correction, and estimate the instrument drift correction. GRCOMP is an easy-to-use program in an interactive way with the user. On the other hand, An disadvantage of GRCOMP is that it is designed to process the data from the global-range model G gravimeters only. One of the

advantages of GRCOMP is the utilization of the least-squares adjustment technique to provide standard deviations of the station gravity values as a tool for judgment the executed gravity loops in the field.

Both programs have been used to process the same loop (Fig. 5-2), that includes the new absolute gravity station in Helwan (named SRI5), the triangulation station O1, and the IGSN-71 gravity station in Helwan (Cairo-B). Seven LaCoste and Romberge relative gravimeters have been used to conduct this loop. The loop consists of 63 total observations, 9 observations per gravimeters. The results show agreement, in the point gravity value, between GRCOMP and GNPA programs within 0.005 mGal, after performing the least-squares adjustment [Dawod and Alnaggar, 1997].

5.3 Performed different solutions to arrive at the best optimum results for the ENGSN97 network

In this section, the developed program GNPA, given in the previous section, has been run to adjust the entire ENGSN97 gravity network. Of course, there are several items or criteria, associated with the adjustment of such entire network. These items depend upon the way of treating the gravimeter drift function, i.e., linear or non-linear; the way of treating the five absolute gravity stations included in the network, i.e., only one fixed or all absolute stations are taken as weighted parameters; the way of treating the gravimeter reading observations for the two different LCR used G and D

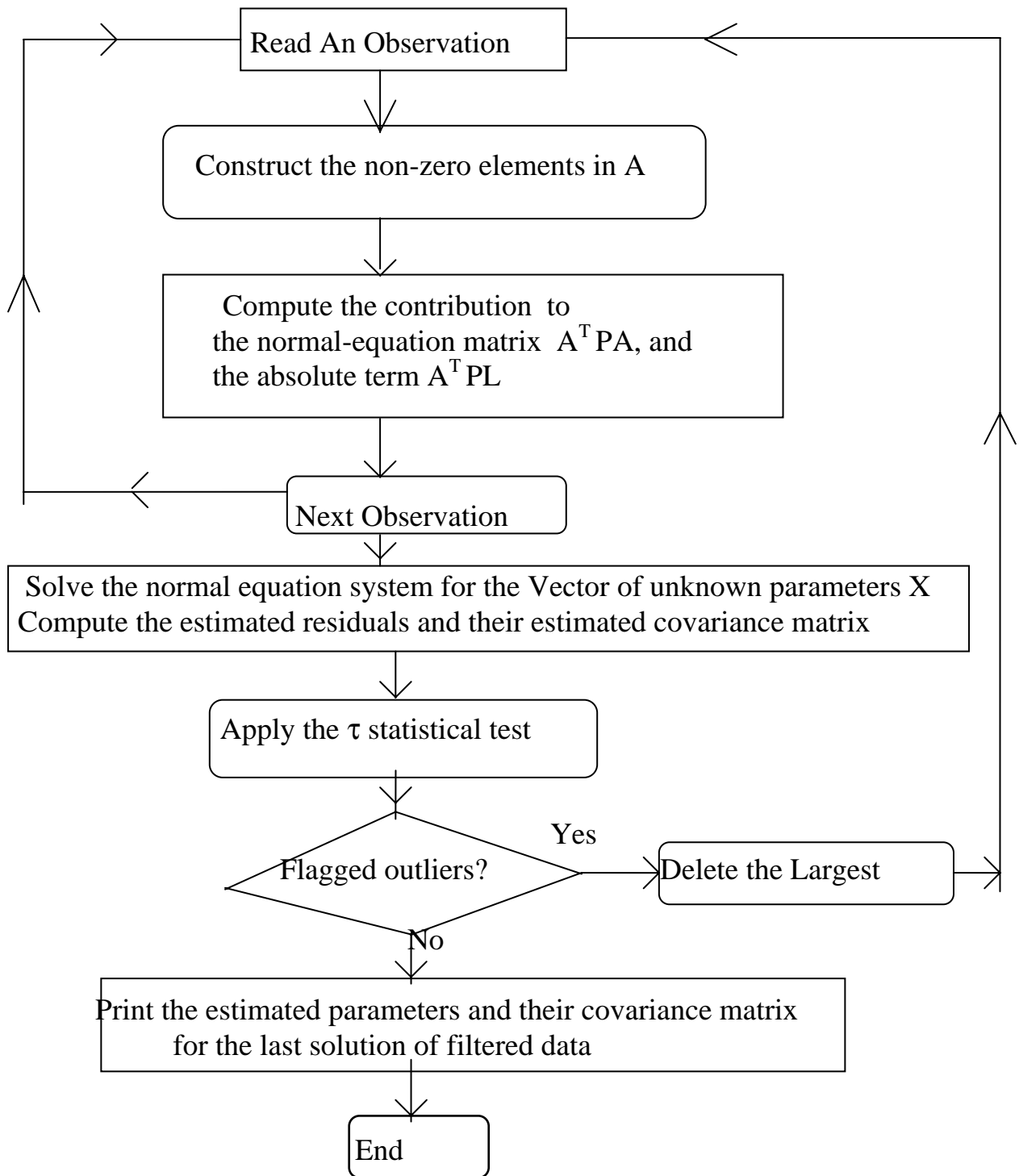

Fig 5-3

The Flow Chart of The GNPA developed Program

models, i.e., introducing different weights for both of them; the way of treating the different involved observation loops in the network according to the length and the time span of observations for each loop, i.e., introducing different weights for different loops. All these items must be investigated first, one at a time, in order to end up with the best optimized solution for the ENGSN97 network, in which all significant influence factors have been taken into account . Finally, for the best solution, any existing outliers in the observations, should be removed one at a time, until the best solution is completely filtered out, which gives the final best estimates for the point gravity values of the network, along with their accuracy estimates. Such process, of course, necessitates that the above mentioned developed software, to be run several times, leading to several solutions of the network, for final assessment of the obtained results. In this context, one can stipulate the required solution into the following six ones:

- (1) Holding only one absolute station fixed for the assessment of the accuracy of the relative against the absolute gravity values, considering the gravimeter drift to be linear.
- (2) Treating all absolute stations as weighted parameters to investigate the consistency between the relative and absolute gravity measurements, considering the gravimeter drift to be linear.
- (3) Repeating the same second solution, but with treating the gravimeter drift to be non-linear in nature, to check the effect of higher order drift validity.
- (4) Repeating the same second solution, however, with introducing different weights for the gravimeter readings, for both models G and D LCR type used gravimeters.

- (5) Fixing the second solution, again, as a standard base for comparison, and introducing different weights for different observation loops of the network.
- (6) Applying an outlier detection procedure for the assurance of the ENGSN97 quality of the final results.

Each one of the above listed solutions, will be presented and analyzed below in separate sub-sections.

5.3.1 First solution: Introducing one absolute gravity station as completely fixed in the adjustment of the network

The purpose of this solution is to investigate the consistency between the relative gravity measurements, taken by both G and D models of LCR gravimeters, and those absolute gravity measurements, taken at five stations only by the FG5 absolute free-fall device. In this case, one absolute gravity station only is held fixed, which is taken in our case here as the SRI5 station at Helwan (Fig. 3-1), as the nearest absolute station to the center of gravity of the entire ENGSN97 network. In other words, the remaining four absolute stations will be retained aside, as if they were not absolutely measured at all. Following the same computational approach, of assigning very large weights for absolute station to be held fixed, the corresponding diagonal element of the normal-equation matrix pertaining to SRI5, will be assigned a very large value. In this case, an estimate of the gravity value at each of the four absolute stations will be obtained after the least-squares adjustment process, which gives one a chance to be compared against the already-known absolute value

at the same station. The analysis of the difference between the two sets of gravity values, for those four absolute stations, will indicate a good idea about the consistency between the relative and absolute gravity measurements performed in our network here. Of course, such an adjustment follows the ordinary known minimal-constrained approach of the least-squares adjustment.

Table 5-3 summarizes the statistics of the differences between the known absolute gravity values, and the corresponding estimated values from the above adjustment, for the four absolute stations mentioned above. From this table, it can be seen that such differences range between -0.032 and 0.049 mGal, with a mean value of 0.007 mGal, and RMS of 0.029 mGal. Recall that, the assigned precision, in terms of standard deviations, for all relative gravity measurements were taken as 0.030 mGal. This means that the above mentioned differences are almost in the same order of the precision of the relative gravity measurements, which indicates the existing consistency between both types of gravity measurements, namely the absolute and relative measurements. From table 5-3, it can be noticed also that the only difference between the absolute and relative gravity values, which takes a negative sign, occurred at station SRI1, located at the basement of SRI building at Giza, for whose absolute standard deviation was estimated to be relatively large (0.005 mGal), as compared to the other remaining four absolute stations (standard deviations of 0.002 mGal). This result could be attributed to the fact that, there were some sort of vibrations found during the absolute measurements of SRI1 station, that certainly affect its final precision.

Table 5-3

Statistics of the differences between the estimated and known gravity values for the four absolute stations when treated as completely unknowns

Differences (Absolute-Estimated)	-0.032, 0.004, 0.006, 0.049 mGal
Minimum Difference	-0.032 mGal
Maximum Difference	0.049 mGal
Mean Difference	0.007 mGal
RMS	0.029

5.3.2 Second solution: Introducing appropriate weights for the absolute gravity stations

In the previous sub-section, while only one absolute gravity station is held fixed, the remaining four absolute stations were considered as completely unknowns. However, this is not the case in reality, since there are reliable values for absolute gravity known at these stations. Therefore, the appropriate way is to make benefit of such important information at all the five absolute stations, by considering them as quasi-observables with their estimated weights from the absolute measurement technique. Following the same approach of treating the absolute gravity stations, as quasi-observables or weighted parameters, with their appropriate estimated standard deviations, as obtained from the absolute measurement technique, as introduced at the end of section 4-4, the residual equation for each one of the five absolute stations will be:

$$V_i(\text{abs}) = g_i(\text{to be estimated}) - g_i(\text{ absolute}), \quad i = 1,2,3,4, \text{ and } 5$$

This means that each value of the absolute gravity station, will receive a certain correction or residual $V_i(\text{abs})$, after the adjustment. Of course, all those five pseudo-observations or residual equations, will be added to the ordinary system of observation equations for relative gravity measurements, while the whole system is combined together and will be solved simultaneously. One requirement here is to assign some appropriate weights for those five pseudo-observations, which is taken as the reciprocal of their variances, as estimated from the absolute measurement technique used, for which the actual standard deviations range between 0.002 mGal and 0.005 mGal (section 3-3). Accordingly, the second solution is carried out on the basis of the above concept.

Again, there will be an estimated gravity value, for each one of the five absolute gravity stations, after the least-squares adjustment of the combined original relative measurements of the network, and the absolute measurements at the five stations treated as quasi-observables. In such a case, it will be interesting to investigate the differences between those estimated values, from the combined adjustment, and the corresponding known absolute values, as obtained from direct absolute measurements. Table 5-4 summarizes the statistics of those five differences. From this table, it can be seen that, such differences range between -0.018 mGal and 0.001 mGal, with a mean of -0.004 mGal and RMS of 0.009 mGal. Again here, it is clear that station SRI1 receives the largest negative difference, due to the same problems associated with this station, as stated in the previous sub-section. Consequently, if one disregards this station, the differences between the estimated gravity values

and the known absolute values, for the remaining four stations, will be almost zero value. This means that, the treatment of the absolute gravity stations as quasi-observables, gives almost the same results as if they were treated as fixed quantities, however, the former approach is the best one from the theoretical point of view. In other words, treating the absolute gravity stations as quasi-observables, with relatively high weights, improves the overall quality of the ENGSN97 gravity network, when compared with treating one or all absolute values at their fixed quantities. Such improvement, in the overall processing of the network, was found to be 11%. It should be noted here that, this particular second solution, will be considered as the standard solution for all subsequent comparisons, for investigating the influence of the other remaining factors, affecting the final results of adjusting the entire network, as stated above.

Table 5-4

Statistics of the differences between the estimated and known gravity values at the five absolute stations when treated as quasi-observables or weighted parameters

Differences (Absolute-Estimated)	-0.018, 0.0, 0.0, 0.001, 0.001 mGal
Minimum Difference	-0.018 mGal
Maximum Difference	0.001 mGal
Mean Difference	-0.003 mGal
RMS	0.008

5.3.3 Third solution: Investigating non-linear drift against linear drift functions

In this solution, the validity of taking the drift function of the used relative gravimeters as non-linear instead of the usual linear function, will be investigated, whether it could improve the quality of the network or not. A non-linear drift model has been tried for all loops. Therefore, the term on the right-hand side of the gravimeter reading observation equation, say in the general model given by equation (4-9), becomes $d_1 \Delta t + d_2 \Delta t^2$, in which two unknown coefficients d_1 and d_2 are needed to be estimated, instead of only one coefficient in case of linear drift function.

The entire ENGSN97 network was adjusted, again, using the second solution above, after introducing the non-linear drift function. After the least-squares adjustment, an estimated value for the second drift coefficient d_2 was obtained, along with its estimated standard deviation, as one new unknown parameter. In addition, the estimated value for gravity station and their covariance matrix, are obtained as the main output results. The obtained results show the following three remarks:

- * The value of the second term $d_2 \Delta t^2$, of the non-linear drift function contribution, is relatively very small compared to the first part $d_1 \Delta t$, which in most of the cases does not exceed the 5% level.
- * The estimated standard deviation for the drift coefficient d_2 exceeded, in most of the cases, the value of the coefficient itself, which means that the drift coefficient d_2 is statistically insignificant, that is it can not be distinguished from the zero value, from the statistical point of view.

* The adjusted point gravity values of the network attain relatively large values for their standard deviations, at a number of stations, when compared to the corresponding good estimate obtained from the second solution above.

Based on the above obtained results and remarks, it can be concluded that the second part of the non-linear drift function is statistically insignificant, and should be neglected, particularly since it deteriorates the overall quality of the entire gravity network by about 18% in our network here. In other words, the linear drift function for LCR gravimeters will be the best to used instead of any suggested non-linear functions.

5.3.4 Forth solution: Introducing different weights for different gravimeters used

Several gravity surveys shows that the precision of the D model of LCR gravimeters is better than that of the G model gravimeters [Torge, 1989a]. In the previous solutions, all relative observations were assigned a standard deviation of 0.03 mGal, that is equal weights for both G and D LCR gravimeter models. In the present solution, the entire ENGSN97 network was adjusted, again, using a better precision (standard deviation of 0.02 mGal) for the observations carried out by the D model of the relative gravimeters. This data series contains 248 observations in 37 virtual loops. The rest of the observations were assigned a standard deviation of 0.03 mGal, for the G model gravimeters.

The obtained results, in terms of the estimated standard deviations of the point gravity values of the entire ENGSN97 network stations, indicated that there is a slight improvement in the precision (in the order of approximately 13%), as compared to those obtained from the second solution above, where equal weights were used. This may be due the fact that the number of the observations of the D-model gravimeters is slightly small compared with the total observations (23 % approximately). Such slight improvement, has occurred especially for the stations observed by the d model gravimeters in addition to the original G gravimeters.

5.3.5 Fifth solution: Introducing different weights for loops according to their observation times

Although a gravity loop must not exceed seventy two hours as observation time, it is the author's experience from the field campaigns that the longer the time span of a loop, the more problems encountered in the field regarding the observation circumstances. Tare (unexpected jump) is an example of these sudden problems that are quite difficult to be modeled. In order to avoid these uncertainties, a worse precision (standard deviation of 0.050 mGal) was assigned to all observations taking along the loops, which their observation have been continued for more than one-day. These observations are found to be 228 in 12 virtual loops. The remaining observations of the rest of the loops, observed over a time span less than one day, were assigned the pre-specified standard deviation of 0.030 mGal, which amounted to 857 observations over 39 virtual loops.

The obtained results of the estimated gravity values, indicated that there is slight improvements in their precision compared to the corresponding values from the standard adjustment of the second solution, in the order of approximately 18%.

5.3.6 Sixth solution: After satisfying all significant affecting criteria

Based on the obtained results from the above discussed five solutions, whose used criteria are summarized in Table 5-5, it can be concluded that the best appropriate way of adjusting the entire ENGSN97 gravity network, will be performed with the following items taken into consideration:

- * The five absolute gravity stations should not treated as purely fixed, but taken as quasi-observables with appropriate large weights.
- * Each used gravimeter should be assigned different weight for all observations taken by it, depending upon the reported precision of the manufacturer and by previous investigators, where a linear drift function should be used for all LCR gravimeter models.
- * For all loops observed over span times exceeding the one-day limit, should be assigned less weights for their encountered observations, as opposed to those loops completed in a period less than one day.

Table 5-5

Criteria Employed In The Performed Six Solutions

Sol. No.	Minimal-Constrained Approach	Weighted-Parameters Approach	Linear Drift	Non-Linear Drift	Different Weights For G and D Gravimeters	Different Weights For Loops With Different Observing Time
1	X		X			
2		X	X			
3		X		X		
4		X	X		X	
5		X	X			X
6		X	X		X	X

After satisfying all the significantly influence factors, one the adjustment of the entire ENGSN97 gravity network, another adjustment of the network has been performed, which is named as solution number six (Fig. 5-5). However, such adjustment included all the 1085 gravimeter readings taken over the 51 virtual loops, as collected by using five actual G-model gravimeters and two D-model gravimeters of the LCR type. Of course, one should assume a hypothesis of possible outlier observations, existing for some of those collected gravimeter readings. In order to have meaningful final results, based on good-quality observations, all such erroneous readings must be filtered out from the system, and a best solution is obtained using all the remaining cleaned observations, as will be given in the next sub-section.

5.3.7 Final solution: After filtering out all outlier observations

Filtering out the observations from existing outliers can be simply performed, using the appropriate tau test for detecting outliers, as explained in section 4-5, which is based on testing the normalized residuals against a critical tau value, instead of testing the pure residuals themselves.

In other words, each estimated residual V_i of a gravimeter reading r_i , should be normalized first by dividing its value by its corresponding standard deviation. The critical value of the tau statistic is then computed, based on the degree of freedom and the probability level using the student t-distribution function. If the normalized residual T_i exceeds the computed critical limit, the corresponding observation is suspected to contain some sort of gross errors, and hence, should be rejected from the system. The least-squares adjustment

is repeated again using the remaining observations, after rejecting the outliers, and a new set of estimated residuals can be obtained, and the tau test is performed again, and repeating the process until all measurements are cleaned out. The usual way, from the theoretical point of view, as stated in section 4-5, is to reject only one observation at a time, whose normalized residual is the largest in each solution. However, the practical experience of the designer plays an important role in this respect, where he can automatically reject more than one observation, from the results of the same solution.

For the ENGSN97 gravity network, in our hands here, eight consecutive solutions were repeated, for the purpose of detecting and rejecting outliers, until no more outliers are flagged. A total of 44 observations out of the original 1085 observations have been flagged and removed. These observations constitute only about 4 % of the total number of the measurements, which is another indication of the goodness of the ENGSN97 network. The solution of adjusting the network, as performed free from all the rejected 44 outliers, represents the final best optimized solution for our ENGSN97 network.

Comparing the estimated standard deviations of the final solution, with the corresponding values as obtained from the sixth solution, one can notice significant improvement in the overall precision of the finally adjusted network. In other words, the removal of all existing outliers from the set of gravimeter readings, will certainly improve the overall quality of the final solution of the network. Such improvement amounts to approximately 37%.

5.4 Gravity changes at some locations in Egypt

Recall from section 3-3 that, few older gravity stations have survived in the last two decades so that they are re-observed again in the ENGSN97. Two stations of the IGSN71 network are still exist and, hence, they were included in the ENGSN97 gravity network. Similarly, five stations of the older national gravity net, NGSBN77, are also included. The rest of the stations were completely lost, according to the reconnaissance made before the design of the ENGSN97 network (section 3-3). A comparison has carried out between the old and new gravity values at six of these stations, as illustrated in Table 5-6. From this table, one can find that, for Cairo-B station of the IGSN71 net, a change of 0.069 mGal is found. For the five NGSBN77 stations, the changes range from - 0.031 to + 0.040 mGal. In other words, one can say that there is a change of the gravity value in the eastern part of the Egyptian territory, of about 0.011 mGal on the average, over the period of about twenty years.

Table 5-6

Changes of Gravity Values At Some Locations In Egypt

No.	Location	Old Network	Gravity Changes (ENGSN97- Old) (mGal)
1	Helwan	IGSN71	0.069
2	Helwan	NGSBN77	-0.026
3	Zagazig	NGSBN77	0.005
4	Aswan	NGSBN77	0.040
5	Ras Gharib	NGSBN77	0.009
6	El- Zafarana	NGSBN77	-0.031

There are several factors that stand behind these changes such as the instrumentation, observational techniques, and the different processing and adjustment criteria employed in different networks. For example, the NGSBN-77 final adjustment is based on the Pogov's method of successive iteration that yields standard deviations of the gravity values range between 0.02 - 0.13 mGal (section 4-1), compared to the corresponding range from 0.002 to 0.048 mGal for ENGSN97 network. Also, the environmental changes and the density change could attribute some changes in the gravity values [Dawod and Alnaggar, 1997]. More investigations are needed to justify these gravity changes, especially from the point of view of local and regional crustal deformations.

5.5 Essential characteristics of the final solution of the ENGSN97 network

The final solution of the ENGSN97 has been obtained, in, the previous sub-section, based on the following processing properties:

- Using weighted parameter approach of least-squares adjustment for the five absolute gravity stations,
- Using 0.02 mGal standard deviation for the D-gravimeter relative gravity observations,
- Using 0.03 mGal standard deviation for the G-gravimeter relative gravity observations,
- Using standard deviation of 0.05 mGal for long gravity loops completed over one-day period, and

- Using standard deviation of 0.03 mGal for loops completed within a period of less than one day, and
- Using linear-drift model for LCR relative gravimeters,
- Applying outlier detection routine for cleaning the data from gross errors.

The final solution of the ENGSN97 contains 1045 observations for the 150 gravity stations, after removing 44 outlier observations. A number of 133 virtual gravimeters was used in terms of estimating the orientation and the drift unknowns for each virtual gravimeter. Hence, there were 408 unknowns to be estimated, and 632 degrees of freedom. It may be worthwhile to mention here that, for the best statistical estimate of a set of unknown parameters, from another set of observed quantities, the number of unknown parameters should not exceed the double of the number of degrees of freedom in the system. This condition is comfortably satisfied, in our case here of the final solution of the ENGSN97 network, as the number of degrees of freedom is 50% more the included number of unknown parameters. The most essential information of the final adopted solution of the ENGSN97 network are summarized in Table 5-7.

It may be interesting to investigate the distribution of the residuals, of the 1045 cleaned gravimeter readings, as estimated from the final solution of the network, which are depicted in Figure 5-4. From this figure, it can be seen that, those residuals range between ± 0.07 mGal, with a distribution peak over the interval between zero and 0.005 mGal. The general trend of such a distribution, approximately follows the ordinary Gaussian normal distribution

curve. This indicates that the remaining residuals of the cleaned gravimeter readings, are representing random errors only, with their mean value approaching the statistical mean value of zero. In other words, such cleaned used gravimeter readings are not affected by any sort of systematic errors or biases, associated with the used instruments, and used observational techniques and computations.

Concerning the estimated gravity values at the network 150 stations, the obtained results indicate that the minimum adjusted gravity value was 978679.776 mGal at Abu-Sombol station while the maximum adjusted gravity value was 979504.981 mGal at Balteem station. Therefore, the gravity range over Egypt is 825.205 mGal with an average gravity value of 979126.005 mGal. As an indication of the precision of the ENGSN97, the standard deviations of the adjusted gravity values range from 0.002 mGal to 0.048 mGal. Fig. 5-5 depicts the distribution of the standard deviations of the adjusted gravity values.

It is worth to mention here that, after finishing the data processing and the final adjustment solution of the ENGSN97 network (section 5-3-6), the author had the chance to check the obtained results at the Technical University in Graz (TU-Graz), Austria. The data of ENGSN97 have been re-processed and re-adjusted again on the university mainframe computer using the classified computer programs available in the physical geodesy department of TU-Graz.

Table 5-7

**Essential Information For The Final Adjustment
Of The ENGSN97 Network**

Number of stations	150	
Number of observations	1045	
Number of loops	51	
Minimum station separation	0.136	Km
Maximum station separation	128.144	Km
Average station separation	65.988	Km
Number of actual gravimeters	7	
Number of virtual gravimeters	133	
Number of unknowns	408	
Number of degrees of freedom	637	
Minimum standard deviation of gravity values	0.002	mGal
Maximum standard deviation of gravity values	0.048	mGal
Minimum adjusted gravity value	978679.776	mGal
Maximum adjusted gravity value	979405.981	mGal
Gravity range over Egypt	825.205	mGal

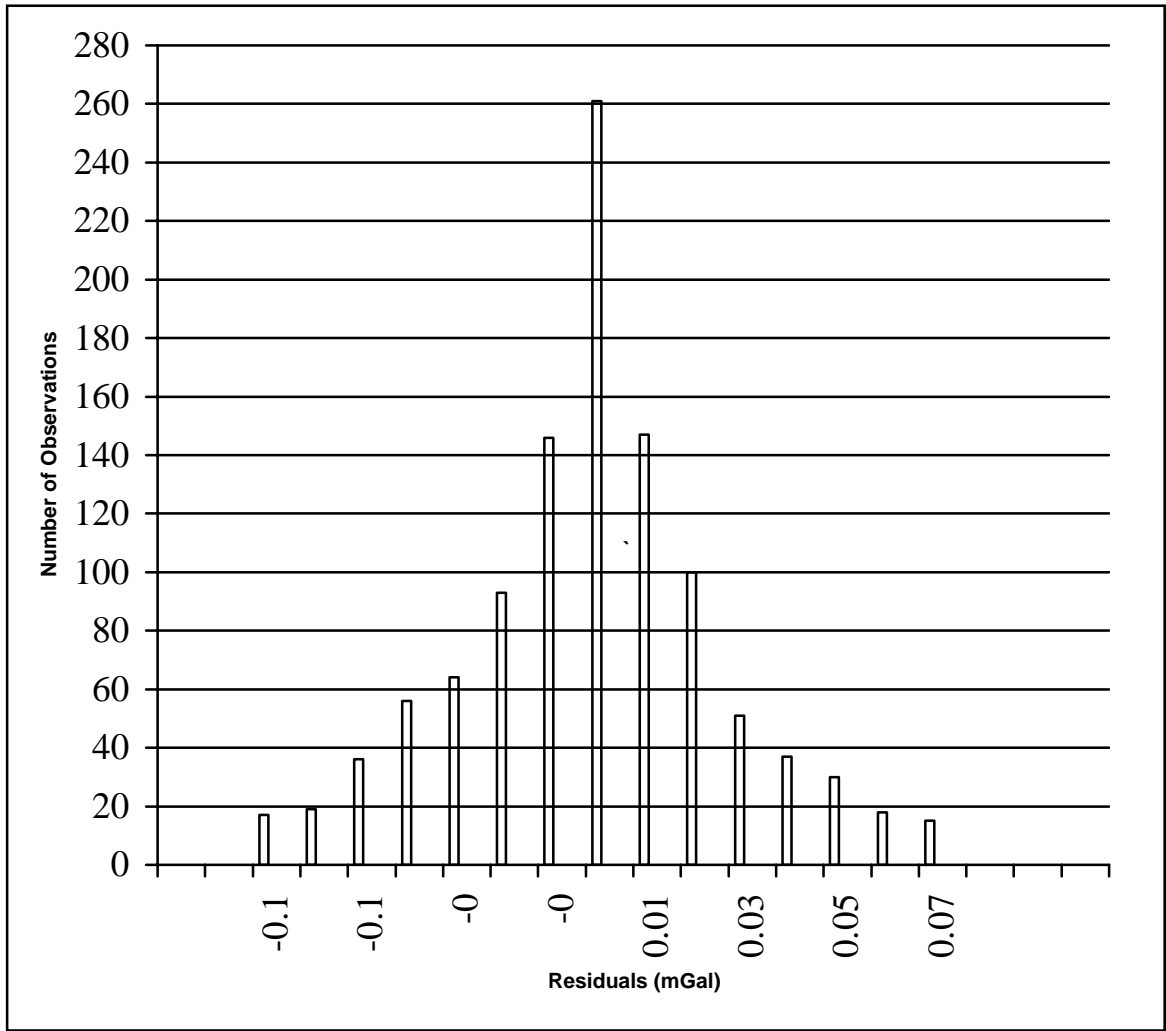

Fig. 5-4

Frequency Distribution of the Residuals of the Gravimeter Readings Over the ENGSN97 Network

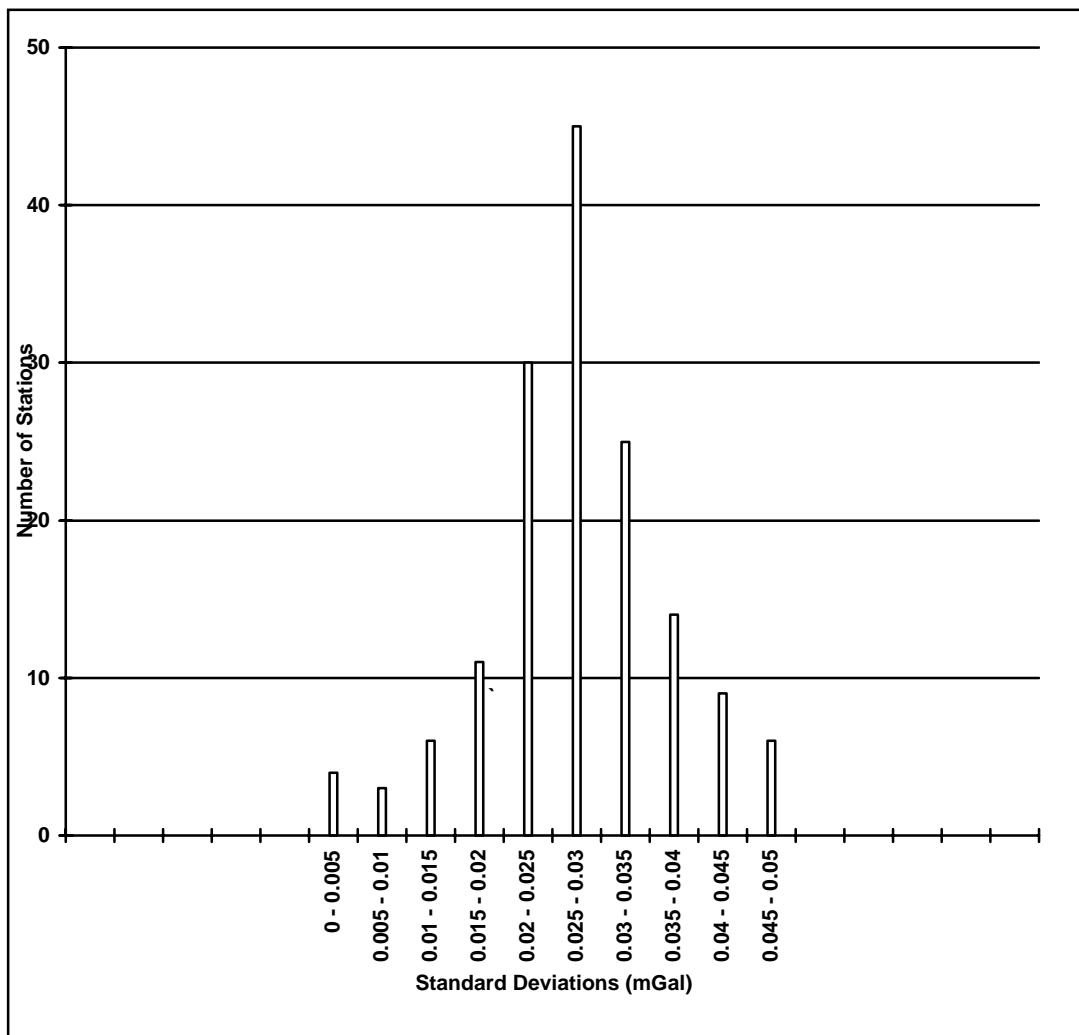

Fig. 5-5

Distribution of the Standard Deviations of the Adjusted Gravity Values For The 150 Gravity Stations Of The ENGSN97 Network

The results show an agreement in the order of few microGals between the final solution presented in section 5-3-6 and that solution of TU-Graz [SünKel, 1998]. This means that, this check proves that all processing and adjustment stages carried out, by the author at the SRI, for ENGSN97 are of high quality and reliability and emphasis that ENGSN97 has a high-level of precision as a gravity datum for Egypt. This has been supported by the performed re-adjustment of the network at TU-Graz, using different independent computer packages.

The final adjusted gravity values, at all the 150 stations of the ENGSN97 network, as presented above, are used to generate a set of up-to-date gravity anomalies maps for Egypt, according to the theoretical background given in section 2-7, as one of the important applications of gravity networks, in geodesy, geophysics, and other related disciplines, as mentioned in chapter 1. Figures 5-6 and 5-7 illustrate the resulted contour maps of both free-air and Bouguer gravity anomalies, for the Egyptian territory, as produced from a 5'x5' grid of each anomaly, as interpolated from the 150 gravity stations of the ENGSN97 network. From figure 5-6, it can be seen that, the free-air gravity anomalies range between -73.33 mGal and 60.29 mGal, with an average of -3.19 mGal, and RMS equals 22.20 mGal. From figure 5-7, it can be noticed that, the Bouguer gravity anomalies range between -99.16 mGal and 82.85 mGal, with an average of -23.48 mGal, and RMS equals 25.91 mGal.

It may be interesting to compare the free-air gravity anomaly map (Fig. 5-6), as produced by the final adjusted values of the up-to-date ENGSN97

network, with the first reliable free-air anomaly map for Egypt, as produced by Nassar and Alnaggar [1988], which was based mainly on the old NGSBN77 network of first order, as well as some filtered-out gravity stations of the second order established by the General Petroleum Company (GPC). The later map was also based upon some other known heterogeneous geodetic data, which were processed by using the least-squares collocation estimation technique. The examination of the old map, reveals that the free-air gravity anomalies over the Egyptian territory range between -40 mGal and 140 mGal. By comparing the recent and the old anomaly maps, it can be seen that, there are some differences in both results, due to the different gravity data and processing technique employed in each case. It should be mentioned here also that, there are other free-air maps for Egypt, produced by other investigators [e.g. El-Tokhy, 1993; El-Sagheer, 1995].

Furthermore particularly the free-air gravity anomalies, as produced by the final adjusted gravity values of the ENGSN97 network, will be utilized in the gravimetric geoid determination for Egypt, including its comparison and integrating with other geoids previously derived for the Egyptian territory by other different techniques, especially the GPS satellite technique. All such geoid applications, as representing one of the main objectives of the present research study, will be handled in the next chapter.

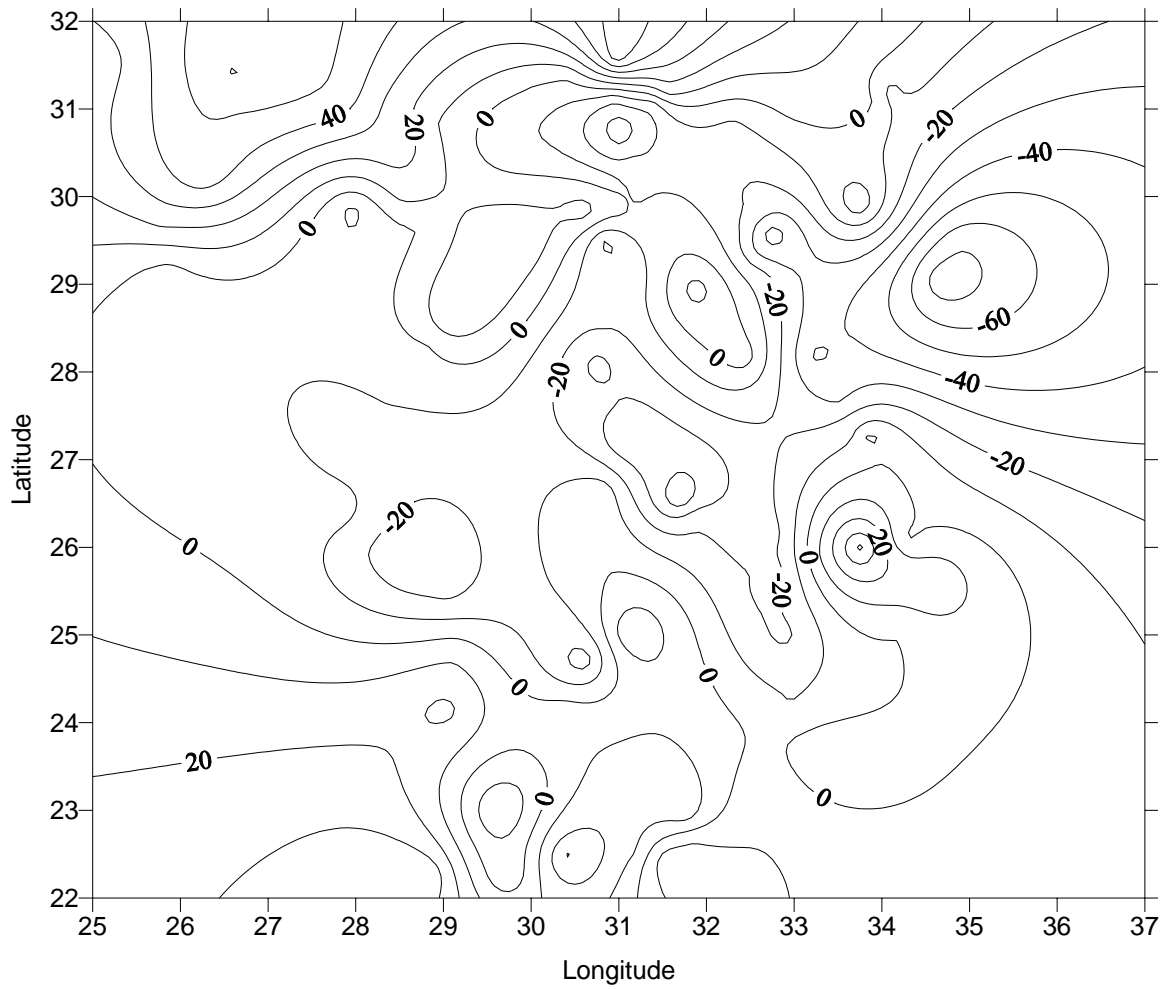

Fig. 5-6

Free-Air Gravity Anomalies Obtained From ENGSN97 Data

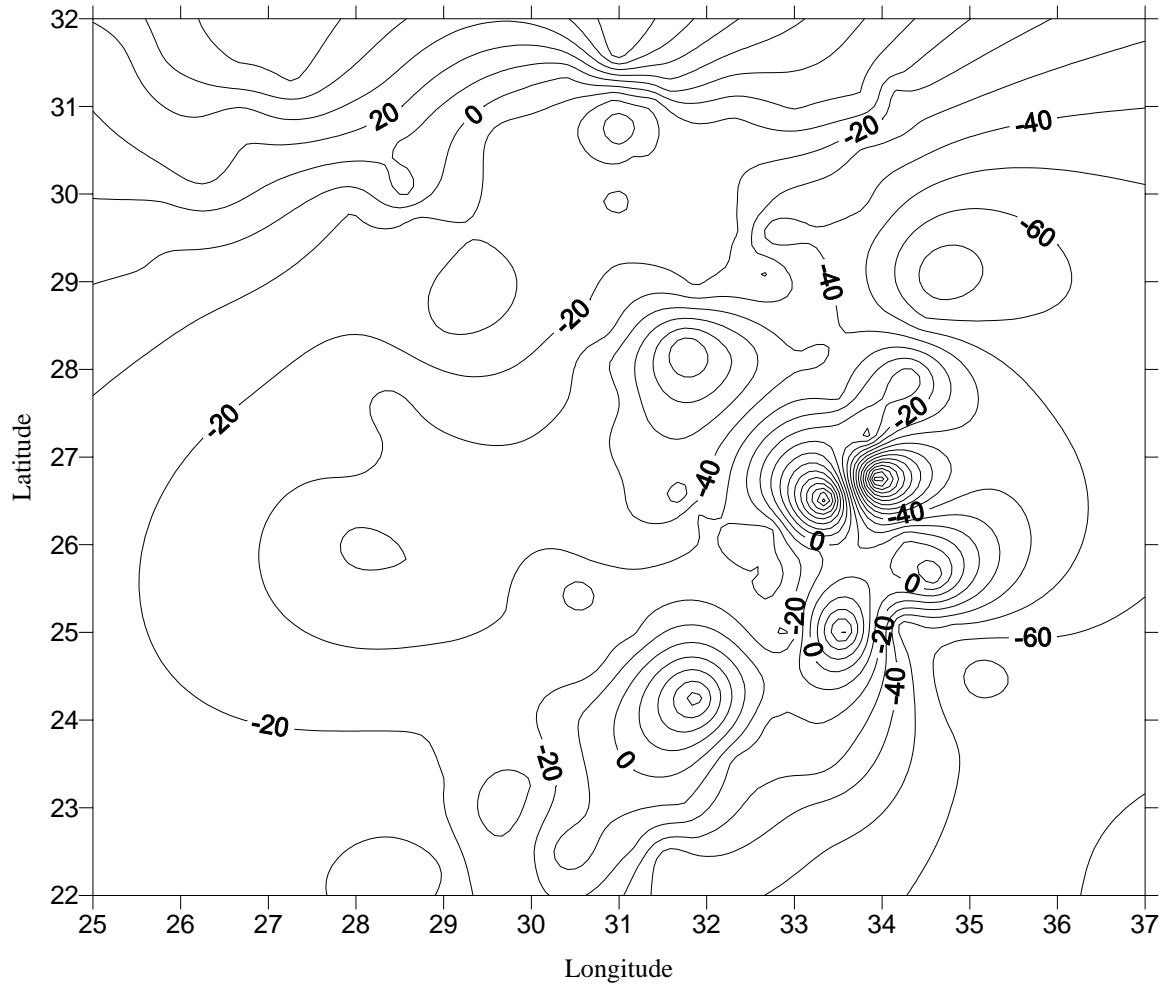

Fig. 5-7

Bouguer Gravity Anomalies Obtained From ENGSN97 Data

Chapter 6

Developing geoid models for Egypt based upon the available gravity and GPS-based positioning data

The geoid is the equipotential surface of the Earth's gravity field approximating mean sea level in an optimum way, and extended under the continents. This definition is traced back to Carl Friedrich Gauss (1828) but the name "geoid" is introduced in 1880 by Listing [Torge, 1994].

The determination of the geoid is an old problem of physical geodesy and a numerous number of geoid evaluations have been carried out world wide, and in Egypt [e.g., Alnaggar, 1986; Nassar et al, 1993; and Shaker et al, 1997a]. A precise geoid is a crucial demand in many scientific and practical fields of applications as:

- * Determination of the size and shape of the Earth,
- * The geoid is the datum for height systems,
- * The geoid undulations are used in geodynamics monitoring applications, and
- * In the last two decades with the rapid growth of GPS applications, a precise geoid is needed to relate the satellite-determined positions to ground surveys.

The main objective of this chapter is to investigate the influence factors affecting the quality and reliability of developing a final precise geoid solution for Egypt that, is based upon the combination of the available gravity and GPS-derived geoid undulations. This is comfortable with the last objective of

the current investigation, as one important geodetic application of the established ENGSN97 gravity network. In order to achieve such an objective, a brief outline of the adopted techniques for geoid determinations, namely the gravimetric geoid computations using the Fast Fourier Technique, and the geometric satellite geoid determination, will be documented first. Then, the remove-compute-restore strategy, as the adopted geoid determination processing techniques in the present research study, will be demonstrated. In addition, the results of developing four gravimetric geoid solutions, a GPS-based geoid solution, and a combined gravity/GPS final geoid solution, will be given in details. The characteristics and statistics of the final recent and accurate combined gravity/GPS geoid solution for Egypt, named here as SRI-GEOID98 geoid, will be given, along with the results of comparing the obtained geoid undulations over some GPS stations with known pure GPS-determined undulations. Finally, a comparison between the final developed geoid model with other local geoid solutions for Egypt, as previously developed by other investigators, will be presented.

6.1 Adopted geoid determination techniques

The geoid is not a simple mathematical surface since its potential is a rather irregular function. Therefore, the geoid is usually described by its deviations from a regular surface, the ellipsoid. Such relationship between the two surfaces, can be simply described either by a linear separation, which is known as the geoid undulation N , or by the angular separation between the plumb line (normal to the geoid) and the theoretical vertical (perpendicular to the ellipsoid) from the same terrain point, which is known as the deflection of

the vertical θ (Fig. 2-5). As mentioned before, the deflection angle θ is usually expressed by its two principle components, ξ in the meridian direction, and η in the prime-vertical direction.

The geoid is determined using several techniques based on a wide variety of using one or more of the different data sources such as:

- * Gravimetric method using surface gravity data,
- * Satellite positioning based on measuring both ellipsoidal heights for stations with known orthometric heights,
- * Geopotential models using spherical harmonics coefficients determined from the analysis of satellite orbits.
- * Satellite altimetry using satellite-borne altimetric measurements over the oceans,
- * Astrogeodetic method using stations with measured astronomical and geodetic coordinates,
- * Oceanographic levelling methods used mainly by the oceanographers to map the geopotential elevation of the mean surface of the ocean relative to a standard level surface.

Only the first two methods are used in this research study and, hence, their basic formulas are outlined in the following sections. The other methods are found in several literature [e.g. Nassar, 1986, and Saad, 1993].

6.1.1 Gravimetric geoid computations

Stokes' boundary value problem (BVP) is the gravimetric determination of the geoid. BVP deals with the determination of a potential field, harmonic outside the masses, from gravity anomalies given everywhere on the geoidal surface. A lot of reference materials are available for this subjects [e.g. Hiskanien and Moritz, 1967]. A brief outline of the gravimetric geoid computation formulas are given here, following the notation of Sideris [1994].

Under the condition of neglecting relative errors of the order of the flattening of the reference ellipsoid, the disturbing potential, T , can be written as a function of the gravity anomalies, Δg , using the Stokes' integral as follows:

$$T = \frac{R}{4\pi} \iint_{\sigma} \Delta g S(\Psi) d\sigma \quad (6-1)$$

where,

R is the mean radius of the Earth,

σ denotes the Earth's surface, and

$d\sigma$ is the infinitesimal surface element, and

$S(\Psi)$ is the Stokes' function (Fig. 6-1) given by the following expression:

$$S(\Psi) = \frac{1}{\sin(\Psi/2)} - 6 \sin(\Psi/2) + 1 - 5 \cos(\Psi) - 3 \cos(\Psi) \ln [\sin(\Psi/2) + \sin^2(\Psi/2)] \quad \dots\dots(6-2)$$

and,

$$\sin^2 (\Psi/2) = \sin^2 ((\varphi_p - \varphi)/2) + \sin^2 ((\lambda_p - \lambda)/2) \cos \varphi_p \cos \varphi \quad (6-3)$$

where Ψ is the spherical distance between the data point (φ, λ) and the computation point (φ_p, λ_p) (Fig. 6-2).

The disturbing potential is related to the geoid undulation, N , through the normal gravity, γ , on a reference ellipsoid (whose normal potential is assumed to equal the gravity potential of the geoid) as:

$$T = \gamma N \quad (6-4)$$

Combining eq. (6-1) and (6-4) gives the geoid undulations as:

$$N = \frac{T}{\gamma} = \frac{R}{4 \Pi \gamma} \iint_{\sigma} \Delta g S(\Psi) d\sigma \quad (6-5)$$

The last equation produces geoid undulations, which are not precisely referred to the geoid, since it neglects the effect of the masses above the geoid, and the obtained undulations will refer to the so-called co-geoid instead. Hence, in order to overcome this problem, a certain technique, known in practice as remove-compute-restore technique, can be used, as explained below.

Equation (6-5) assumes that there are no masses outside the geoidal surface. One of the ways to take care of the topographic masses of density ρ , is Helmert's condensation reduction applied as follows (Fig. 6-3):

- (a) Remove all masses above the geoid,
- (b) Lowering the terrain station P to its projection P_o on the geoid, using the free-air reduction, F (section 2-7-1), and

(c) Restore masses condensed on a layer on the geoid with density $= \rho H$,
 where H is the orthometric height.

This approach gives Δg on the geoid :

$$\begin{aligned} \Delta g &= \Delta g_p - A_p + F + A_{p_o}^c \\ &= \Delta g_p + F + \delta A \end{aligned} \quad (6-6)$$

where,

Δg is the gravity anomaly of point p_o on the geoid,

F is the free-air gravity reduction, equals $0.3086 H$ (mGal/meter),

Δg_p is the free-air anomaly at point P,

A_p is the attraction of the topography above the geoid at station P,

$A_{p_o}^c$ is the attraction of the condensed topography at station P_o , and

δA is the attraction change.

Due to the shifting of masses, the potential changes by an amount called the indirect effect on the potential, is given by:

$$\delta T = T_{p_o} - T_{p_o}^c \quad (6-7)$$

where,

δT is the indirect effect on the potential

T_{p_o} is the potential of the topographic masses at P_o , and

$T_{p_o}^c$ is the potential of the condensed masses at P_o .

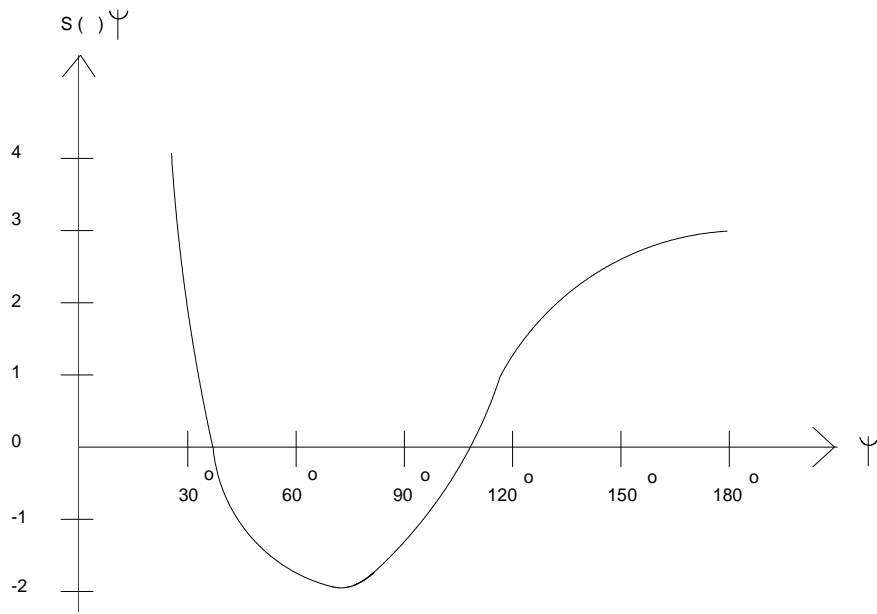

Figure 6-1
Stokes' Function

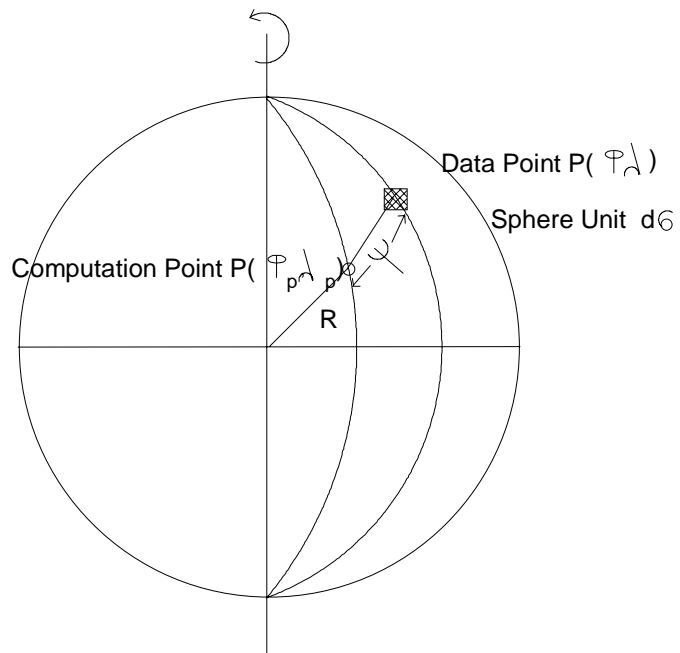

Figure 6-2
Stokes' Sphere

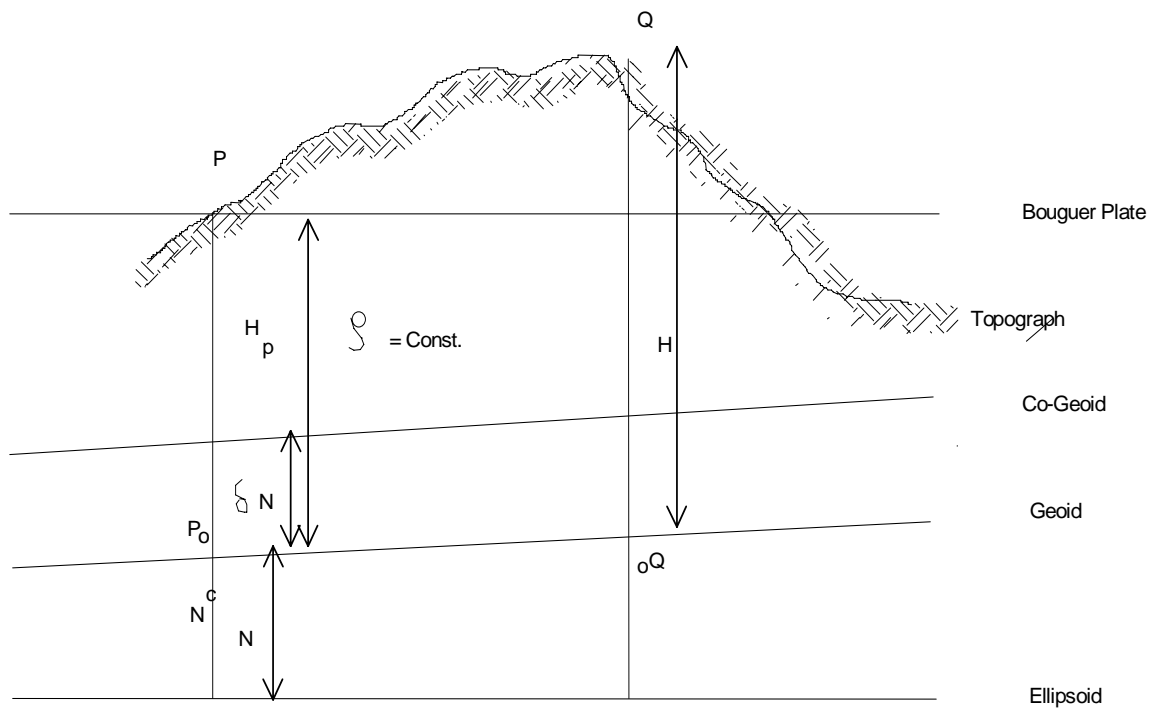

Fig. 6-3

Actual and Condensed Topography in Planner Approximation

Therefore, equation (6-5) produces a surface, which is not the geoid, but a surface is called the co-geoid. Thus, before applying the Stokes' equation, the gravity anomalies must be transformed from the geoid to the co-geoid by applying a small correction, $\delta\Delta g$, called the indirect effect on gravity:

$$\delta\Delta g = - \frac{1}{\gamma} \frac{\partial \gamma}{\partial H} \delta T \tag{6-8}$$

The final formula of the geoid undulations, N , can now be re-written as:

$$N = \frac{R}{4 \Pi \gamma} \iint_{\sigma} [\Delta g + \delta\Delta g + \delta A] S(\Psi) d\sigma + \frac{1}{\gamma} \delta T$$

$$N = N^c + \delta N \quad (6-9)$$

where,

δN is the indirect effect on the geoid, and

N^c is the co-geoidal height computed from the general Stokes' formula (6-5)

However, the evaluation of the Stokes' integral necessitates that, the gravity anomaly field must be continuous. Of course, this is not the case, since the gravity anomaly Δg can be computed at discrete points only, where gravity observations or predictions were made. Consequently, the Stokes' double integral must be transformed to double summation (numerical integration), through a practical procedure for each evaluation, as will be given below.

The use of equation (6-9) requires gravity anomalies all over the Earth for the computation of a single geoid undulation, which is impractical. Some modifications are necessary.

Firstly, eq. (6-5) can be applied in a limited region and the long wavelength contributions of the gravity field can be computed from a geopotential model (a set of spherical harmonic coefficients). Secondly, the integral is computed as a summation using discrete data. Since the density of the gravity data is not generally high, the short wavelength could be computed by using dense Digital Terrain Model (DTM). These frequency contributions are depicted in Fig. 6-4.

The computation of geoid undulations can be given as:

$$N = N^{GM} + N^{\Delta g} + N^H \quad (6-10)$$

$$\Delta g = \Delta g^{FA} - \Delta g^{GM} - \Delta g^H \quad (6-11)$$

where,

GM denotes a geopotential model,

Δg^{FA} denotes free-air gravity anomalies, and

H denotes heights in a DTM.

It should be noticed that, the gravity anomalies used with Stokes' equation have the contributions of the topography and the geopotential model. Therefore, the remove step involves the computation and the removal of the geopotential model and terrain contributions from the free-air gravity anomalies. The restore step involves the restoration of the geopotential model contribution, N^{GM} , and the terrain contribution, N^H (which is called the indirect effect on N) to the geoid undulations.

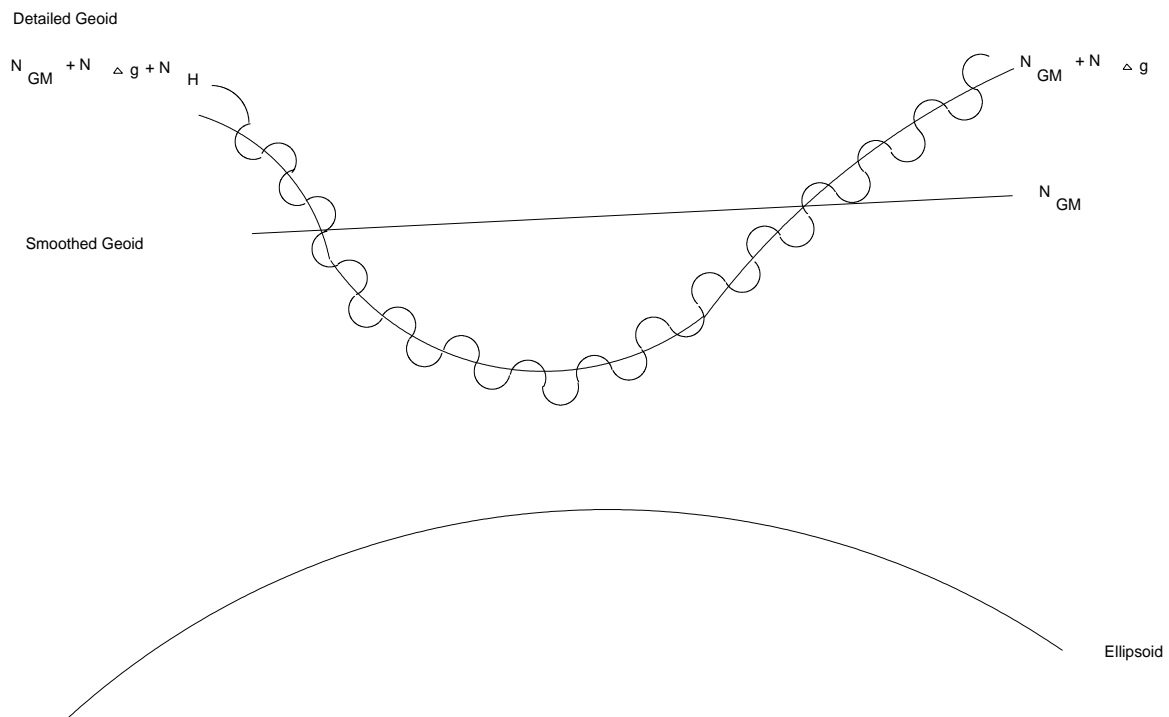

Fig. 6-4
Contributions of Different Data to Geoid Determination

6.1.2 Geometric satellite geoid computations

It is well known that, receiving appropriate signals from artificial geodetic satellites, in which the GPS is the up-to-date satellite positioning system, enables one, after processing, to obtain the three-dimensional Cartesian coordinates (X,Y,Z) of the point on which the receiving antenna is located, as referred to the geocentric datum of the GPS, which is known as the World Geodetic System 1984 (WGS84). Such Cartesian coordinates, can be transformed to their corresponding triplet geodetic curvilinear coordinates (geodetic latitude ϕ , geodetic longitude λ , ellipsoidal height h), related to WGS84 datum. This can be done through an iterative procedure [e.g. Nassar,

1984]. Similarly, if one requires those coordinates relative to a different regional or local datum, the cartesian coordinates relative to WGS84 must be transformed first to their corresponding values relative to the regional datum, by using a set of appropriate reliable existing transformation parameters. Then, the new cartesian coordinates can be transformed to their corresponding curvilinear coordinates relative to the regional datum. In other words, the outcome of any satellite positioning campaign will provide ellipsoidal height h for each point of interest.

The idea of geoid computations, from geometric satellite geodetic results, is to make benefit from the derived satellite ellipsoidal height h , to compute the geoid undulation N at the same point (Fig. 6-5). This necessitates that, the orthometric height H of the same point of interest to be known, since the relationship among those three quantities, is given as $N = h - H$. Of course, for precise determination of N , using this technique, in the order of the same precision of the satellite vertical component positioning, which can nowadays reach few tenth of a centimeter, the orthometric height H must be determined with at least the same precision. The best accurate method for determining H , will be the use of the precise levelling technique supported by correcting the significant systematic errors, particularly the gravity effect [Nassar, 1977].

The above same technique, can be used the other way around. In other words, by obtaining the ellipsoidal height h from the geometric satellite positioning, and with an available precise and reliable geoid, i.e., with known precise geoid undulation N , one can easily obtained the corresponding orthometric height H . Such technique is known in practice as levelling or

orthometric heights from GPS. This is actually the basic reason, for practicing geodisists all over the world, to try all ways to update and refine their knowledge about precise geoid determination. This is actually, what we are trying to achieve for the Egyptian territory, which is the main subject treated in this chapter.

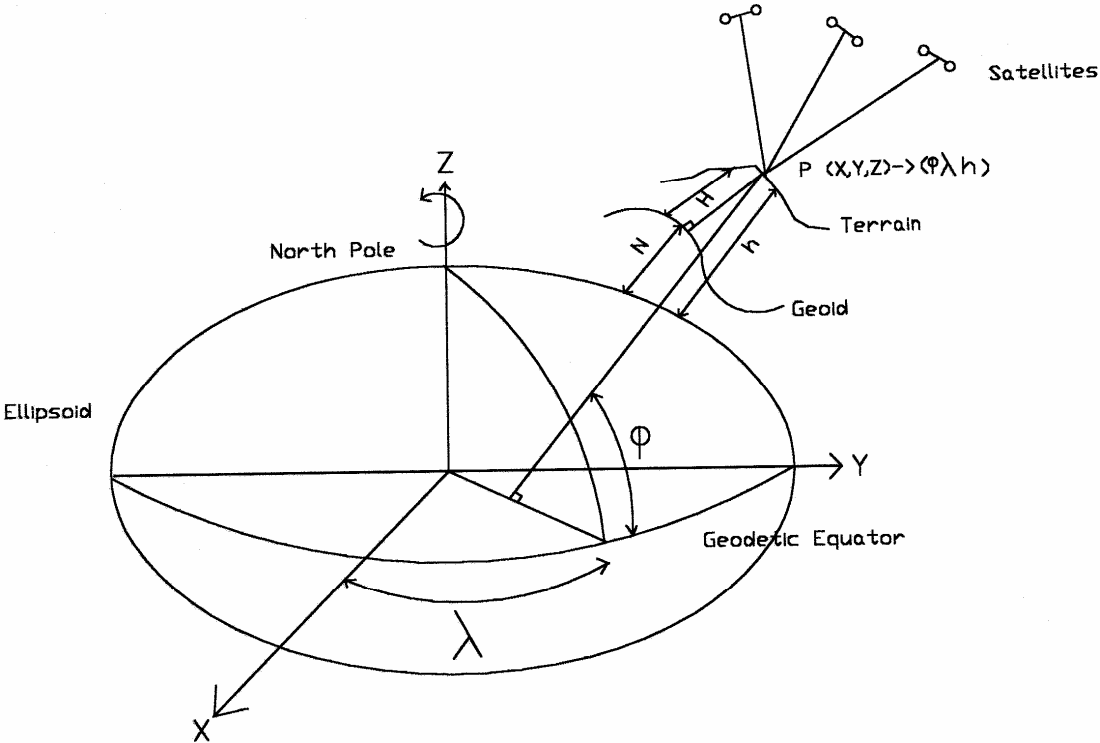

Figure 6-5

Geometric Satellite Geoid Determination

6.2 Adopted geoid determination processing technique

There are several processing techniques for geoid determination, some of which are based on using a single type of geodetic data (astronomical, gravimetric, satellites), while other processing methods depend upon two or more types of such data. The former processing techniques, could mathematically deal with geoid profiling, i.e., determination of geoid undulations at discrete points along a certain profile, having a certain direction (azimuth); or surface fitting two-dimensional least-squares techniques. In this context, there is a mathematical technique known as the Fast Fourier Transformation (FFT), that can be used to facilitate the evaluation of the Stokes' integral, when dealing with gravimetric geoid determination. The later processing techniques, which depend upon using several types of heterogeneous geodetic data, depend mainly on the known mathematical technique of Least-Squares Collocation (LSC). The adopted mathematical processing technique, in the current research study, will be taken as the FFT technique.

Least-Squares Collocation is a mathematical technique for determining the Earth's figure (the geoid) and gravitational field by a combination of heterogeneous data of different kinds in a mathematical procedure that combines both least-squares adjustment and least-squares prediction [Moritz, 1978]. Alnaggar [1986] utilizes the LSC technique to develop the geoid in Egypt using different kinds of geodetic measurements. The main advantage of LSC is its capability to combine different data sources in the computation stage. However, the principal drawback of this technique is the large amount of

computer storage memory and the huge amount of Central Processing Unit (CPU) time required. A recent modified approach is proposed, named the Fast Collocation (FC), based on collocation applied to grided homogenous data in order to overcome the computer huge requirements [Bottoni and Barzaghi, 1993].

The FFT is an efficient computation technique to evaluate convolution integrals provided that the data are given on regular grids. FFT has several advantages as:

- * There is no need for time-consuming numerical summations which are replaced by very efficient multiplications.
- * FFT gives results on the same grid as the initial grid on which the data were provided, i.e., a single run of the FFT program produces geoid undulations on all points of the gravity-anomalies grid.
- * FFT grided output is very suitable for interpolation and plotting purposes.

On the other hand, FFT has some disadvantages. For example, this technique depends on grided data rather than the scatter observed locations which inherently introduces some interpolation errors in creating the required grid. The FFT has been used extensively in geoid determinations world-wide in the last years [e.g. Milbert and Smith, 1996]. The effect of a global geopotential model, as assumed to represent coarse-scale smoother geoid, is removed from the observed gravity measurements. The contributions of the topography are also removed since they are implicitly included in the Stokes' equation to be evaluated. The residual gravity anomalies are used as input to the FFT routine to obtain fine-scale geoid. The final geoid height model is the

sum of the coarse-scale and fine-scale models along with the indirect effect or the terrain contribution. This is called “ the remove-compute-restore” processing strategy as proposed by Schwarz et al. [1990]. Figure 6-6 summarizes the remove-compute-restore processing strategy. FFT can also be used to compute the two components of the deflection of the vertical ζ and η .

6.3 Developing High-Precision Geoids for Egypt

There are many circumstances that affect the computation process of geoid determination. A lot of geoids all over the world have been produced in the last few years, discussing the effects of many items such as the terrain effect, the density and distribution of the data, and the integration of different data sources [e.g. Denker et al, 1996; Kuhtreiber and Rautz, 1996; Veronneau, 1996].

Some of the factors that affect the quality and accuracy of the needed precise geoid model for Egypt have been studied here. Hence, several geoid solutions have been obtained and being compared, until the most precise solution is defined and tested. The effects of the following components have been considered:

- * The amount and quality of the available terrestrial gravity data,
- * The effect of digital elevation models,
- * The terrain corrections in Egypt, and
- * The integration of gravity and GPS-derived geoid models.

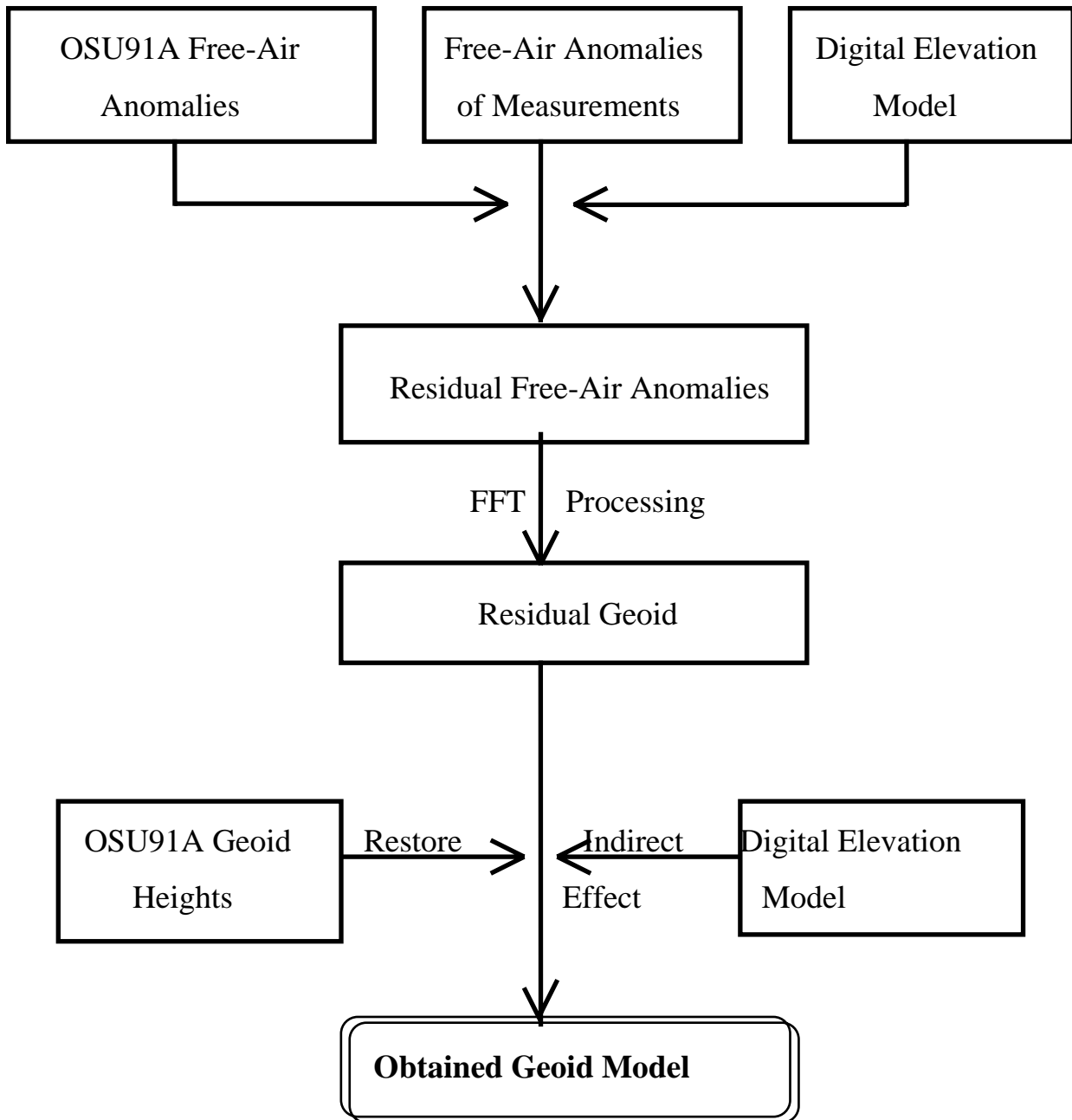

Figure 6-6

The remove-compute-restore FFT processing strategy

Six geoid solutions have been developed relative to the World Geodetic System 1984 (WGS84) datum. These developed geoid solutions could be divided into three sets:

(A) Gravimetric geoids:

Geoid solution 1 utilizes only the 150 gravity stations of the new ENGSN97 network and a global Digital Elevation Model (DEM),

Geoid solution 2 uses all available gravity data (250 stations) and a global DEM,

Geoid solution 3 uses all available gravity data (250 stations) and a local DEM,

Geoid solution 4 uses all available gravity data (250 stations) and a local DEM and investigates the effect of the terrain corrections on the data,

(B) GPS-based geoids:

Using three different data sets of GPS stations with known orthometric heights, Geoid solution 5 developed.

(C) Combined gravity/GPS geoid:

Geoid solution 6 is obtained based on the combination between the pure GPS-based geoid solution 5 and the pure gravimetric geoid solution 4.

The data used and results are presented in the following sections along with a comparison of each solution with some check points, and the statistical results obtained.

6.3.1 Developing Gravimetric Geoids

The FFT technique is utilized in developing four gravimetric geoids for Egypt, i.e., from 22° to 32°N in latitude, and from 25° to 37° E in longitude. A number of FORTRAN computer programs, from the U.S. National Geodetic Survey, are used to perform FFT processing following the remove-compute-restore strategy [Milbert, 1997]. These programs have been modified slightly by the author using the FORTRAN 90 programming language compiler, in order to be run on a PC platform. Three geoid solutions have been obtained to investigate the effect of the number of data used and the contribution of a Digital Elevation Model while the fourth geoid solution investigates the effect of the terrain corrections in Egypt. Each one of those four solutions will be presented below.

6.3.1.1 Geoid Solution 1 (EGY-G1): A gravimetric geoid using ENGSN97 data and a global DEM

The adjusted gravity values of the Egyptian National Gravity Standardization Network (ENGSN97) 150 stations have been used to generate a 5'x5' free-air gravity anomalies grid containing 145 rows and 121 columns, from which the free-air gravity anomaly map in Fig. 5-6 is generated. The utilized global 5'x5' Digital Elevation Model (DEM) is called TOPO5 which is provided by Milbert [1997], and is presented in Fig. 6-7. The OSU91A reference geopotential model was used to provide the long wavelength contributions of the geoid. Two 5'x5' grids of OSU91A geoid heights and free-air gravity anomalies were used in the processing stage. Figure 6-8

illustrates the corresponding free-air anomalies contour map, as generated from the OSU91A geopotential model.

A comparison between the obtained free-air anomalies from the ENGSN97 data (Fig. 5-5), with those of OSU91A geopotential model (Fig. 6-8), shows that 14 out of the 150 stations of the ENGSN97 network, have differences greater than 50 mGal over the OSU91A values. If the tolerance of comparison decreased to 20 mGal, the number of stations increased to 39 stations, as representing about 30% of the network stations. Such great differences give a first remark that the OSU91A geopotential model does not accurately represent the short wavelength of the gravity field in Egypt. Some statistics concerning the above compared anomalies are presented in Table 6-1.

Applying the remove-compute-restore FFT processing strategy, as depicted in Figure 6-6, produces EGY-G1 geoid solution, which is a gravimetric geoid of Egypt. Figure 6-9 presents the obtained geoid model. The geoid undulations have a minimum of -2.02 m and a maximum of 25.39 m with an average value of 14.68 and Root Mean Square (RMS) of 5.80 m. The corresponding geoid undulation of OSU91A geopotential model has a minimum and maximum of 6.77 and 23.12 m respectively, with an average value of 14.81 m and RMS equals 3.29 m. Fig. 6-10 gives a contour map representing the differences in geoid undulations, between the EGY-G1 solution and those deduced from the OSU91A global model. The corresponding statistics of the differences are also summarized in Table 6-2. From this figure and table, one can notice that the differences range from -

10.66 to 12.446 m with an average value of -0.12 and RMS of 4.26 m. It can be also seen that, the differences in undulations over the area with observed gravity are within 2 meters, and the maximum values of the differences exist in void areas, especially over the south western and Red sea regions.

Table 6-1

**Statistics of used anomaly data from both the
ENGSN97 network and OSU91A geopotential model**

Item	Minimum	Maximum	Average	RMS
Latitude	22°N	32°N	-	-
Longitude	25°E	37°E	-	-
Free-Air Anomalies from Observed Data (mGal)	-75.33	60.29	-3.19	22.20
Bouguer Anomalies from Observed Data (mGal)	-99.16	82.85	-23.48	25.91
Free-Air Anomalies of OSU91A (mGal)	-97.65	104.060	7.04	22.81
Differences in Free-Air Anomalies (Local – OSU91A)	-162.02	117.95	-9.37	0.78

Table 6-2

Statistics of EGY-G1 & OSU91A geoids

Item	Minimum	Maximum	Average	RMS
EGY-G1 Geoid	-2.02	25.39	14.68	5.80
OSU91A Geoid	6.77	23.12	14.81	3.29
EGY-G1 - OSU91A	-10.66	12.45	-0.12	4.26

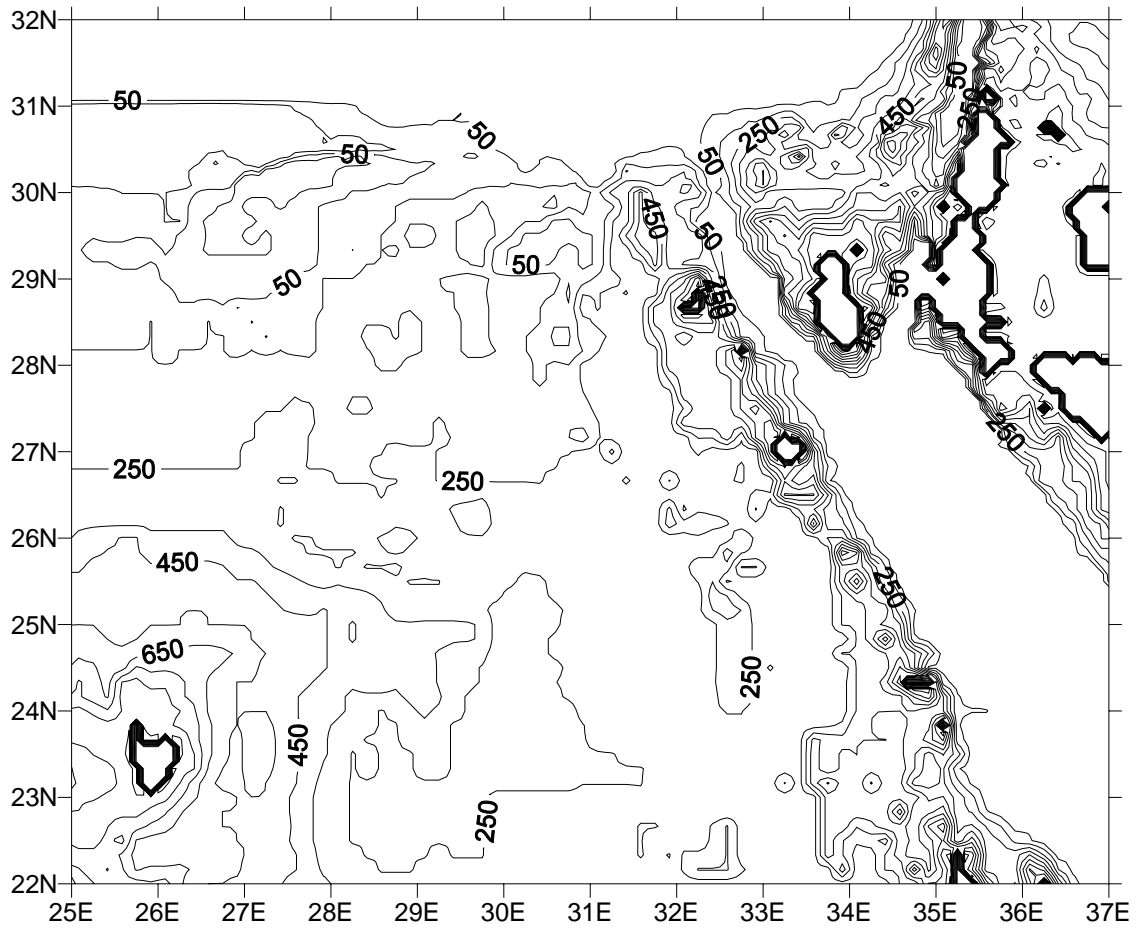

Figure 6-7

The TOPO5 Global DEM Model

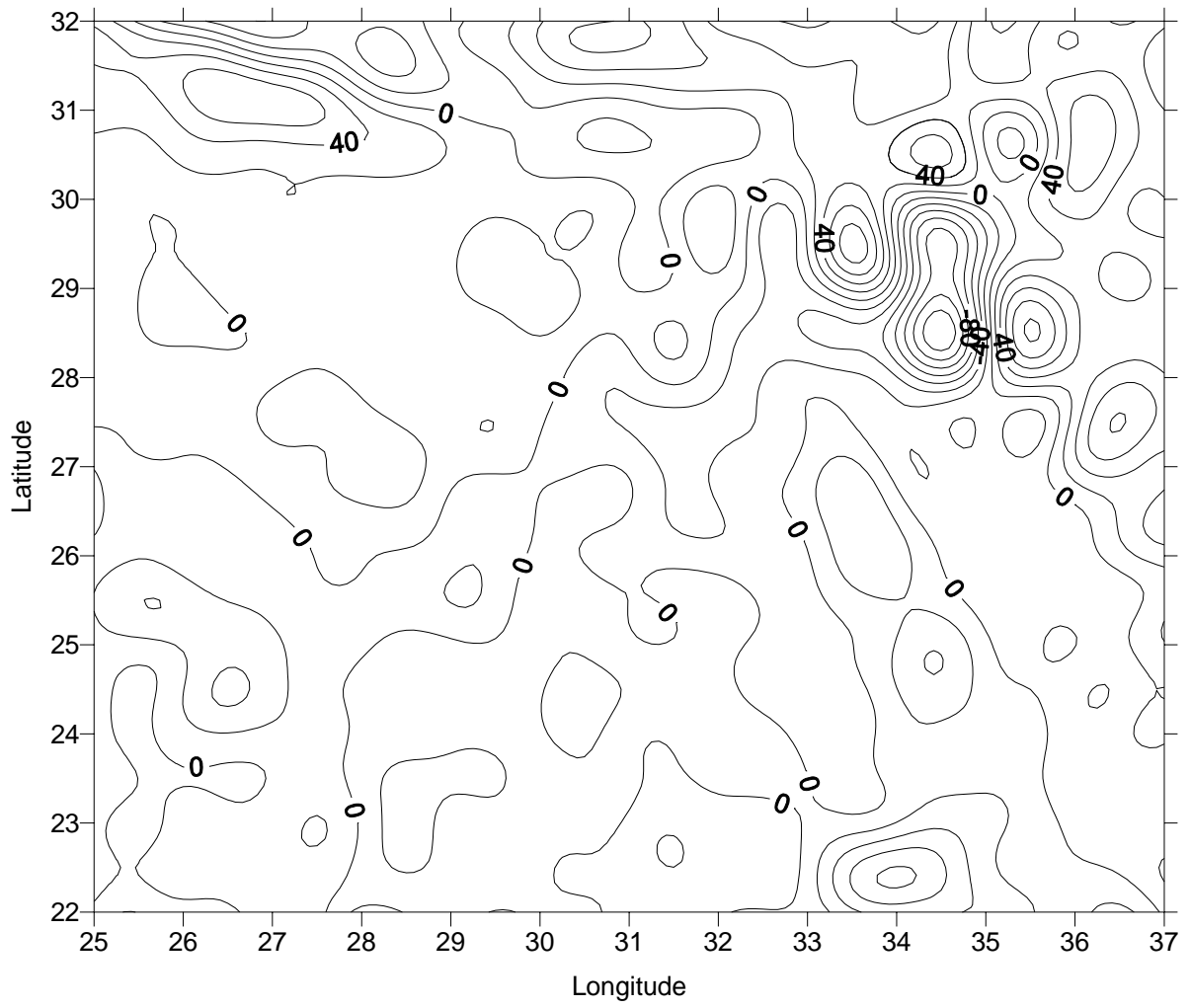

Fig. 6-8

Free-Air Gravity Anomalies of OSU91A model

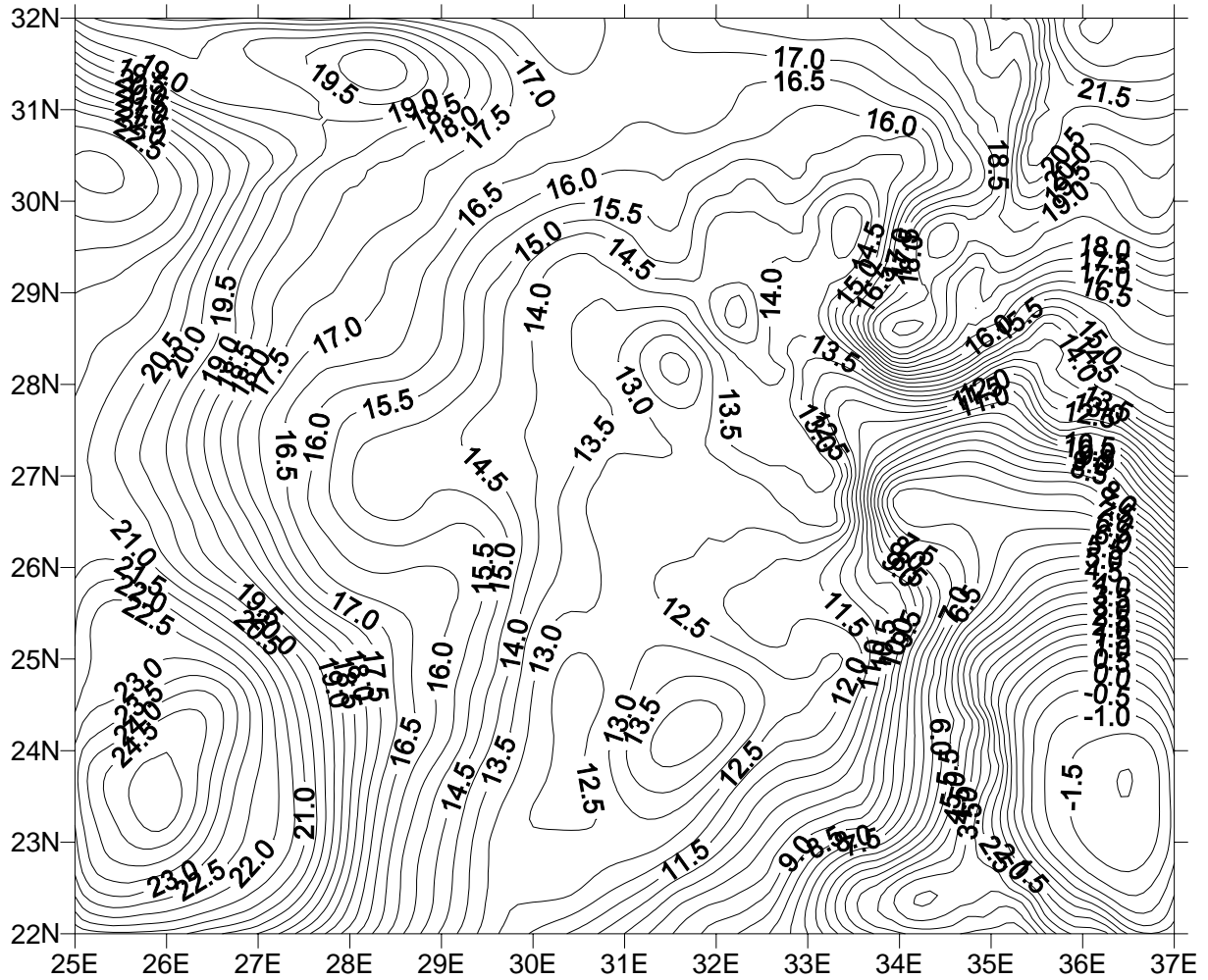

Figure 6-9

**EGY-G1: A Developed Gravimetric Geoid Model 1
(using ENGSN97 data and a global DEM)**

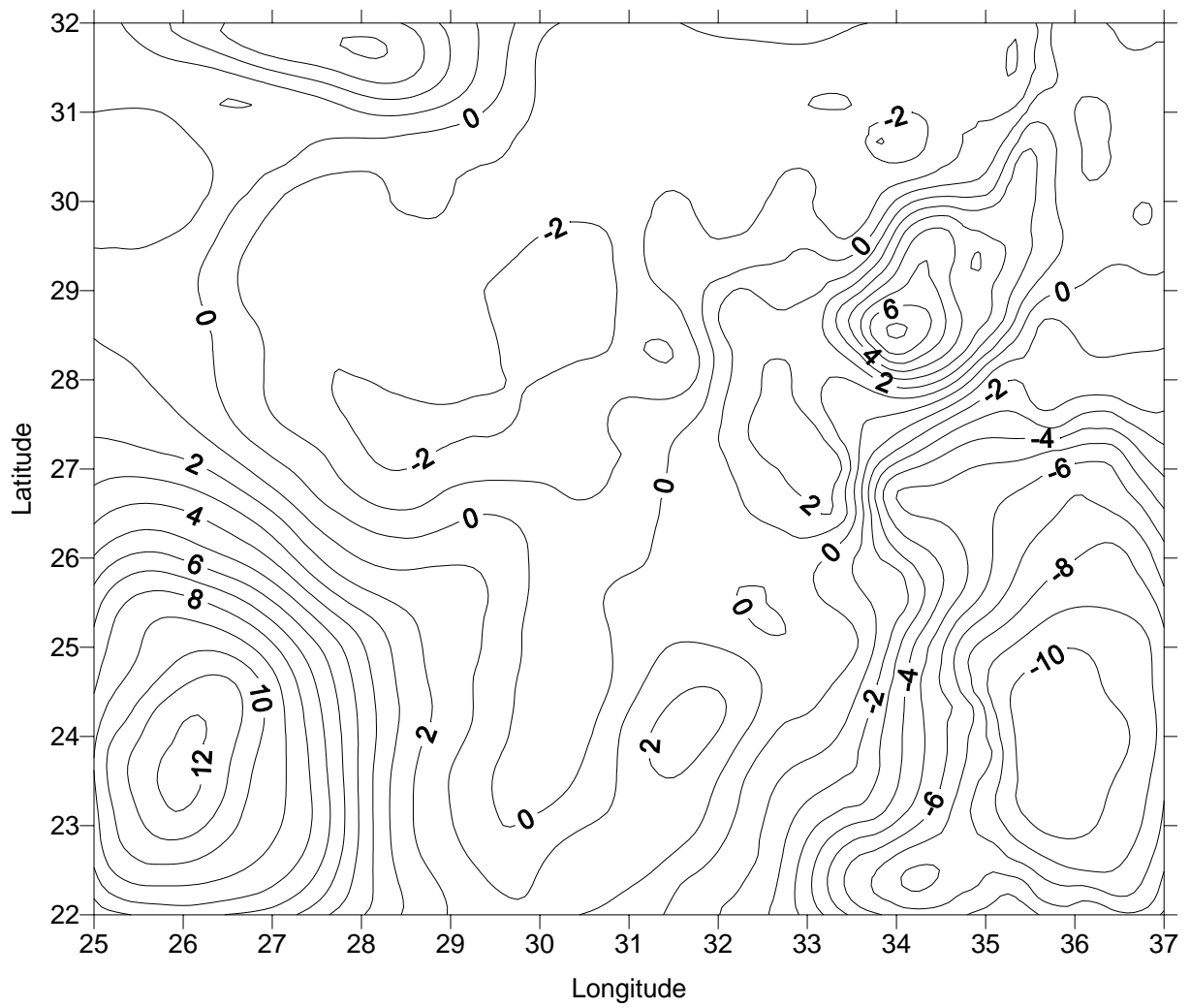

Figure 6-10

Differences Between EGY-G1 and OSU91A Geoid Models

6.3.1.2 Geoid Solution 2 (EGY-G2): A gravimetric geoid using all available gravity data and a global DEM

The second trial in geoid determination is to increase the number of the available terrestrial gravity data. A total of 240 gravity stations (presented in Figure 6-11) have been used in generating this geoid solution. The data used consists of the 150 ENGSN97 stations, 67 NGSBN77 stations, and some gravity stations observed by the Survey Research Institute (section 1-1). The gravity values used are considered as first-order stations. Less-accurate gravity measurements were not considered in this solution in order to develop a precise geoid. The OSU91A geopotential model is utilized again as the reference geoid model and the global DEM (TOPO5) is also used. Therefore, the item which is changed between Geoid 1 and Geoid 2 is the amount of the terrestrial gravity measurements. The remove-compute-restore technique is applied in the same manner as in the previous solution.

The obtained geoid EGY-G2, is illustrated in Fig. 6-12, where it has geoidal heights range from 4.31 m to 23.73 m with an average value of 14.70 m and RMS of 3.48 m. A comparison has been made between the two geoid solutions, EGY-G2 and EGY-G1, in order to investigate the effect of having more gravity data on the final results. The differences between the two solutions are directed in Fig. 6-13, whose statistics are also summarized in Table 6-3. From this figure and table, one can find that, the differences in undulation range from -12.86 m to 9.23 m with an average value of -0.02 m. From Fig. 6-13 , it can be noticed that, the greater differences between the two geoid solutions are existing in areas where no common gravity stations are

existing. Another comparison between the EGY-G2 and OSU91A geoid models shows that the minimum and maximum differences are -5.46 and 8.93 m respectively with an average value of -0.10 m and RMS of 2.02 m, as also shown in Table 6-3. Such results indicate also that, there is more consistency between the regional geoid solution EGY-G2 and the global geoid model of OSU91A, as compared to the case of the first solution EGY-G1. Consequently, based on the above results, it can be recommended that, the present ENGSN97 gravity network should be densified, by adding new enter station points, to be included in developing a high-precision geoid for Egypt.

Table 6-3
Statistics of the differences between EGY-G1
and EGY-G2 geoid solutions

Item	Minimum	Maximum	Average	RMS
EGY-G1 Geoid	-2.02	25.39	14.68	5.80
EGY-G2 Geoid	4.31	23.73	14.70	3.48
EGY-G1 - EGY-G2	-12.86	9.23	-0.02	4.13
EGY-G2 - OSU91A	-3.67	4.32	-0.14	2.02

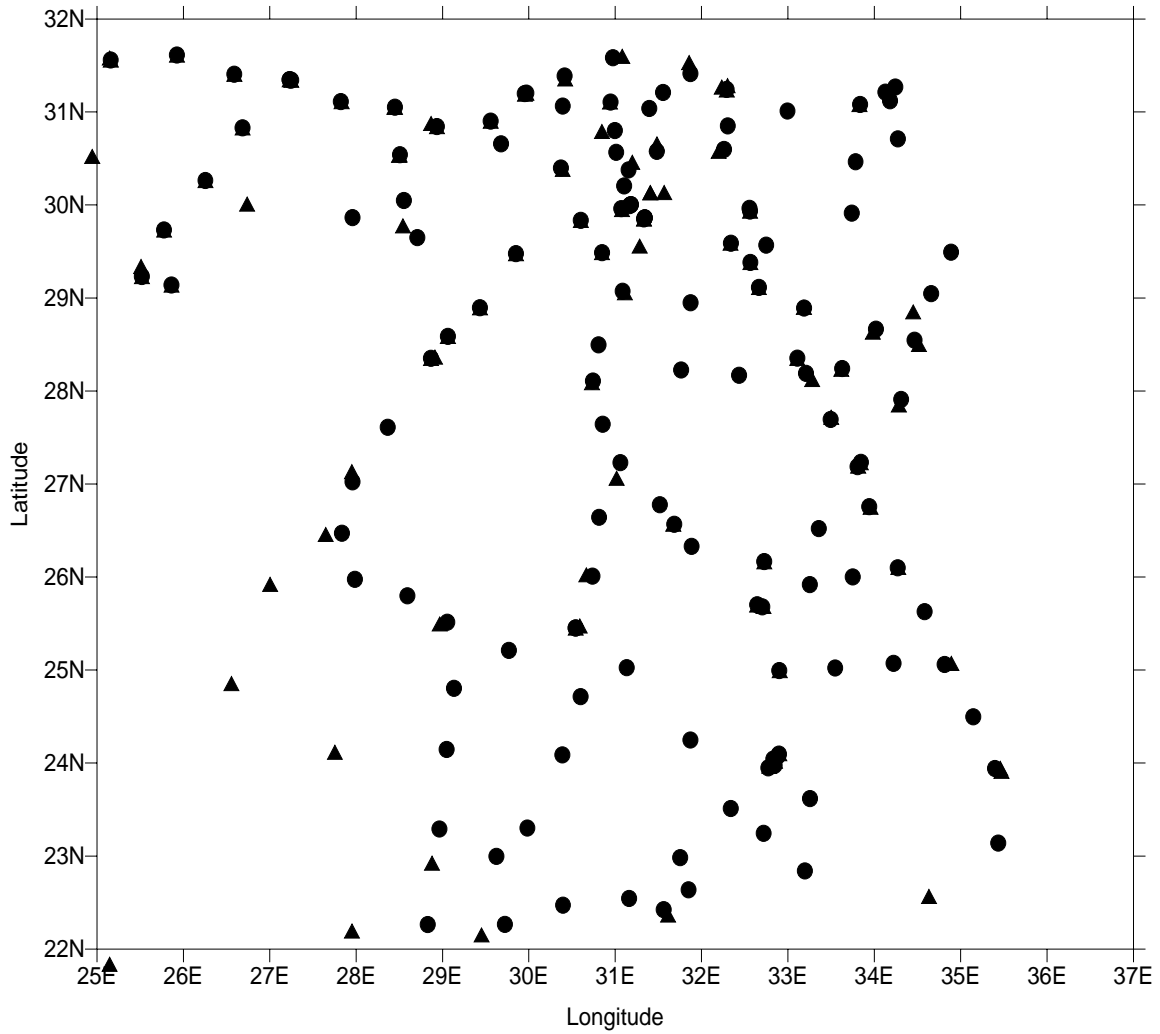

λ ENGSN97 Gravity Stations

σ Other Gravity Stations

Figure 6-11
The Distribution of Point Gravity Data Used
in Developing EGY-G2 Geoid Solution

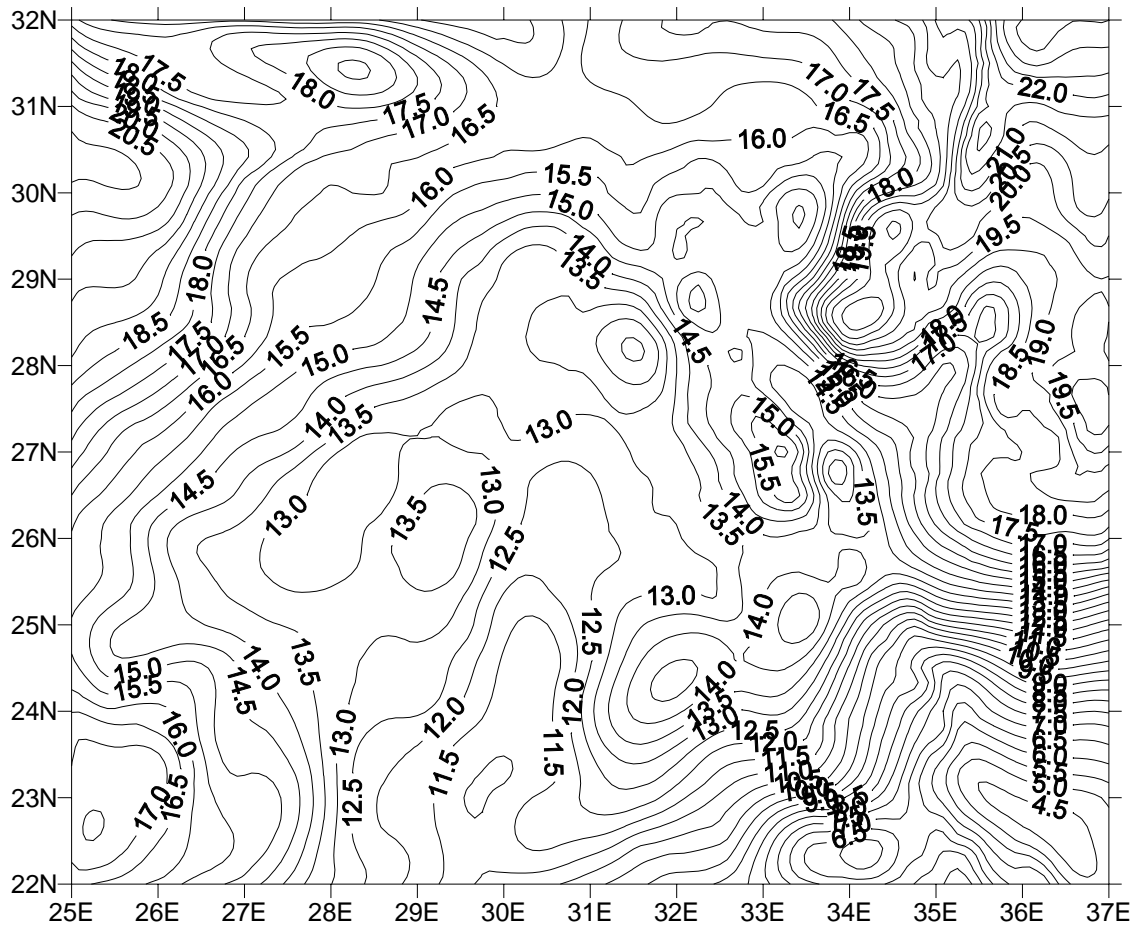

Figure 6-12

The EGY-G2 Geoid Solution

(using all available gravity data and a global DEM)

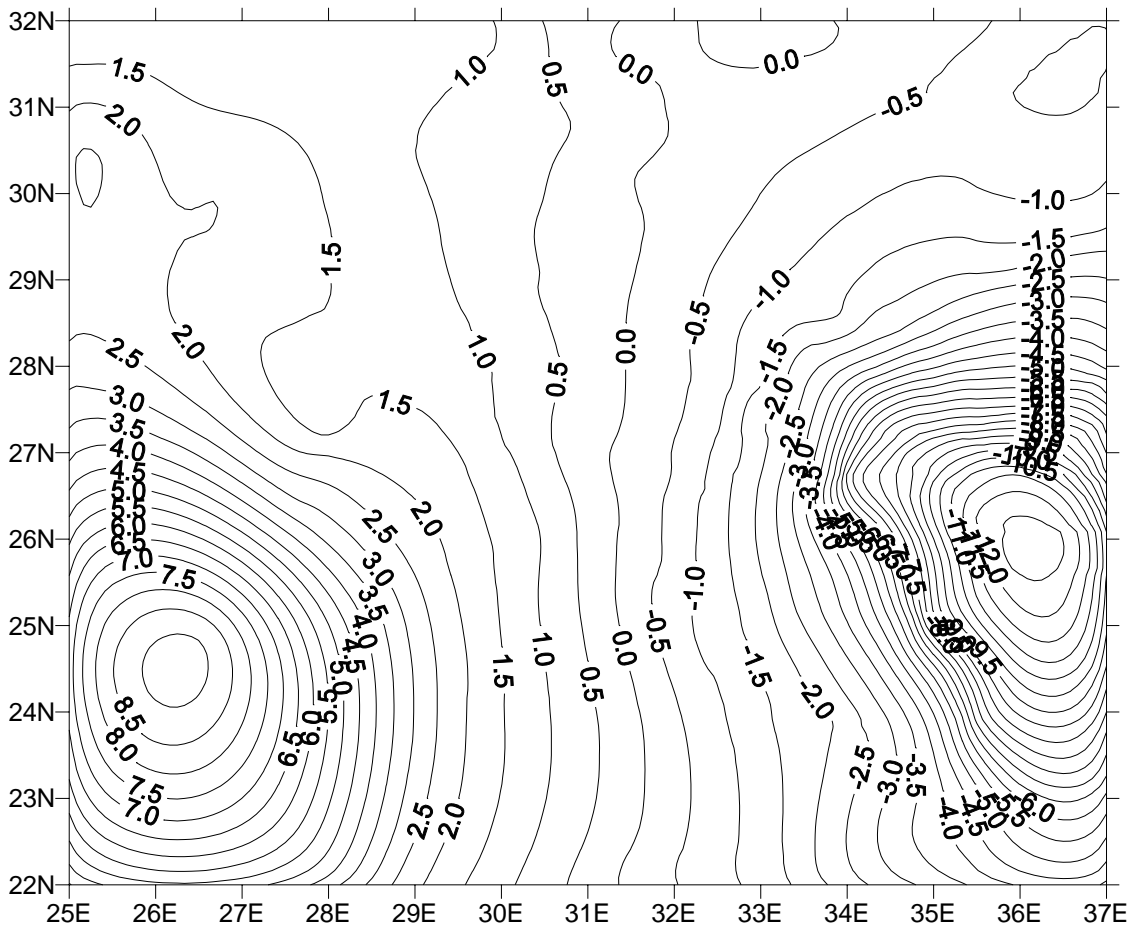

Figure 6-13

The differences between EGY-G1 and EGY-G2 geoid solutions

6.3.1.3 Geoid Solution 3 (EGY-G3): A gravimetric geoid using all available gravity data and a local DEM

The third developed gravimetric geoid solution for Egypt depends basically on using a local instead of a global DEM model. The local DEM utilized is a 5'x5' grid extending from 22° to 32° N and from 25° to 37° E based on 11231 data points, as generated from the developed 15'x15' DEM made by Al-Sagheer [1995]. This local DEM is considered of low resolution due to the nature and distribution of the elevation data, and the relatively large grid size, that have been used in its development. However, such a local DEM, was the most recent DEM for Egypt, available to the author at the time of carrying out the present research.

From Fig. 6-14, it can be found that, the local DEM in a 5'x5' grid has values range from -122 m to 2723 m with an average value of 240 m and RMS of 205 m. Recall from Fig. 6-7 that, the global DEM has values range from -132 m to 1829 m with an average value of 308 m and RMS of 249 m. Comparing both figures 6-7 and 6-14, one finds that, the differences between the two DEM models have a minimum value of -997 m and a maximum value of 989 m with an average value of -60 m and RMS equals 220 m. The great differences between the two DEM models, exist in mountainous areas over the Egyptian territory, namely in south Sinai, the Red Sea coast, and the south western borders of Egypt..

The same 240 gravity stations, employed in the second developed geoid solution EGY-G2, were utilized again, along with the OSU91A

geopotential model as the reference geoid, to perform the third geoid solution. The obtained geoid EGY-G3, in this case, is depicted in Fig. 6-15, from which it can be seen that, the geoidal heights range from 6.39 m to 22.94 m with an average value of 15.20 m and RMS of 2.99 m.

A comparison has been made between the last two geoid solutions in order to investigate the effect of using different DEM models, namely a local DEM instead of a global one. The differences, between those two geoid solutions, are shown as a contour map in Fig. 6-16, while their corresponding statistics are listed in Table 6-4. From this figure and table, it is found that, the differences range from -4.86 m to 10.47 m with an average value of -0.50 m and RMS of 2.71 m. From Figure 6-16, it can be concluded that the differences are greatly increased over mountainous areas over Egypt. From Table 6-4, it can be noticed that, there is a slight improvement in the reliability of the third developed geoid solution EGY-G3, as compared to the second solution EGY-G2. In other words, it can be concluded that using a reliable local DEM, instead of a long-wave global one, will certainly improve the quality of the computed gravimetric geoid for Egypt.

In addition, Another comparison between the EGY-G3 and OSU91A geoid models, as summarized also in Table 6-4, shows that the differences between those two models range from -9.74 to 10.56 m with an average value of 0.39 m and RMS of 2.94 m. Table 6-4 summarizes the obtained results. Such results, can indicate that the global geopotential model, as well as the global DEM, are not representing the actual situation of the gravity field and topography over the Egyptian territory.

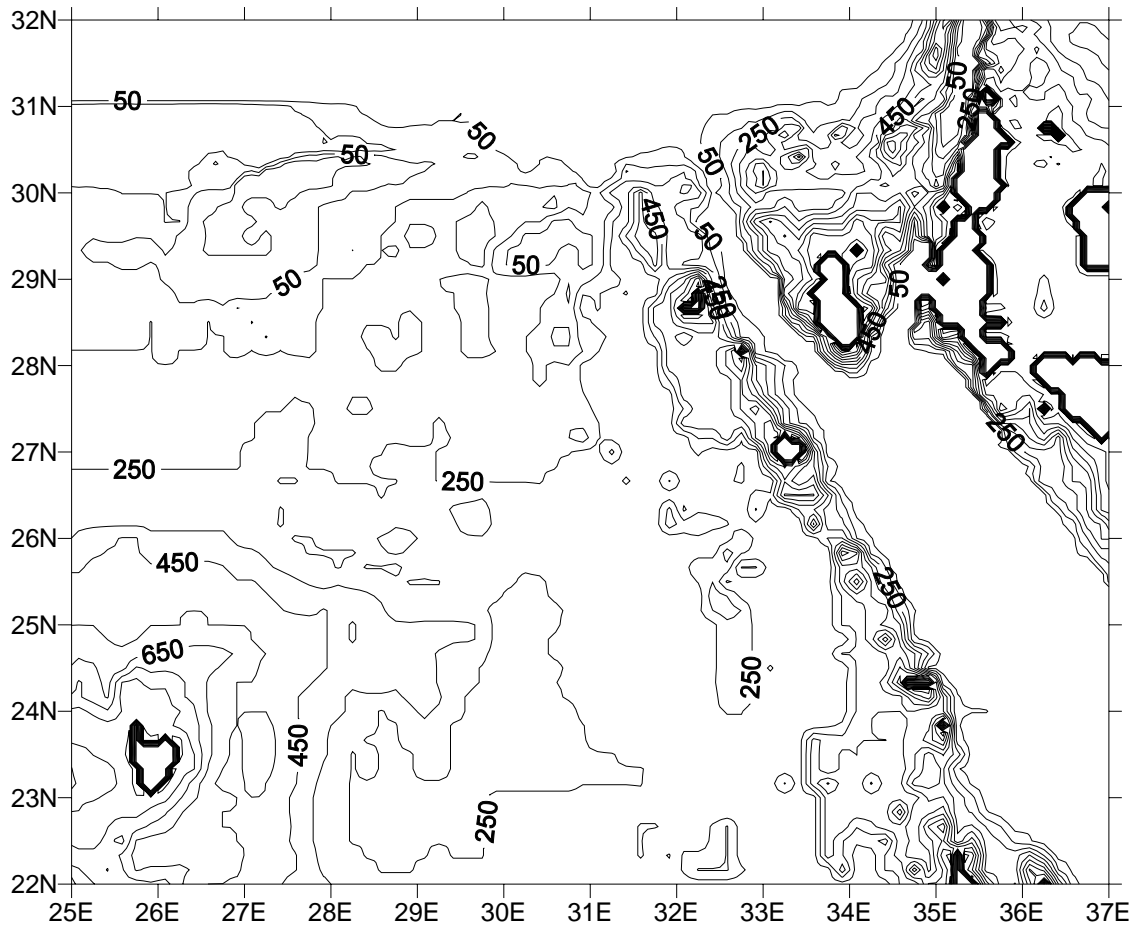

Figure 6-14

**Local DEM model based on the collected
elevation data until 1995**

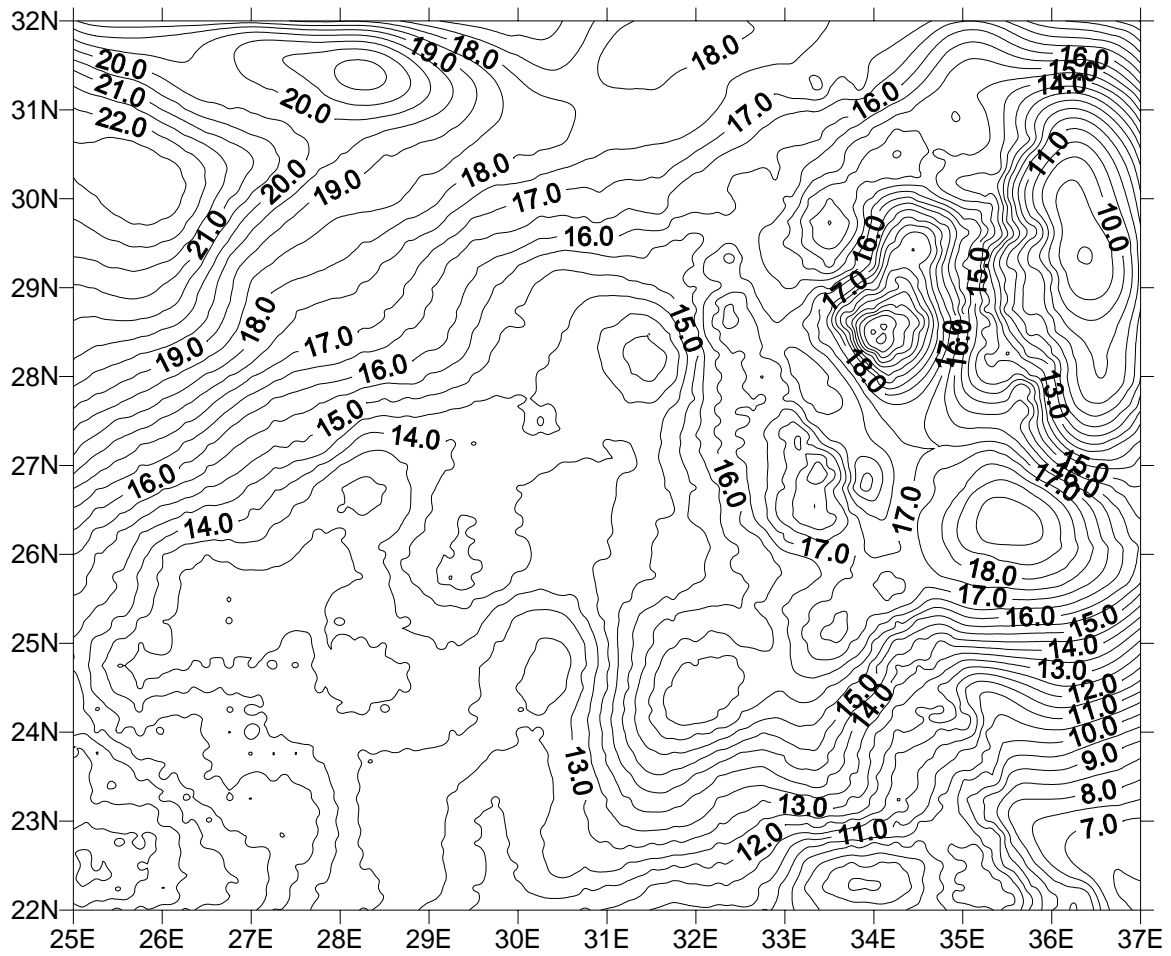

Figure 6-15

The EGY-G3 geoid solution

(using all available gravity data and a local DEM of 1995)

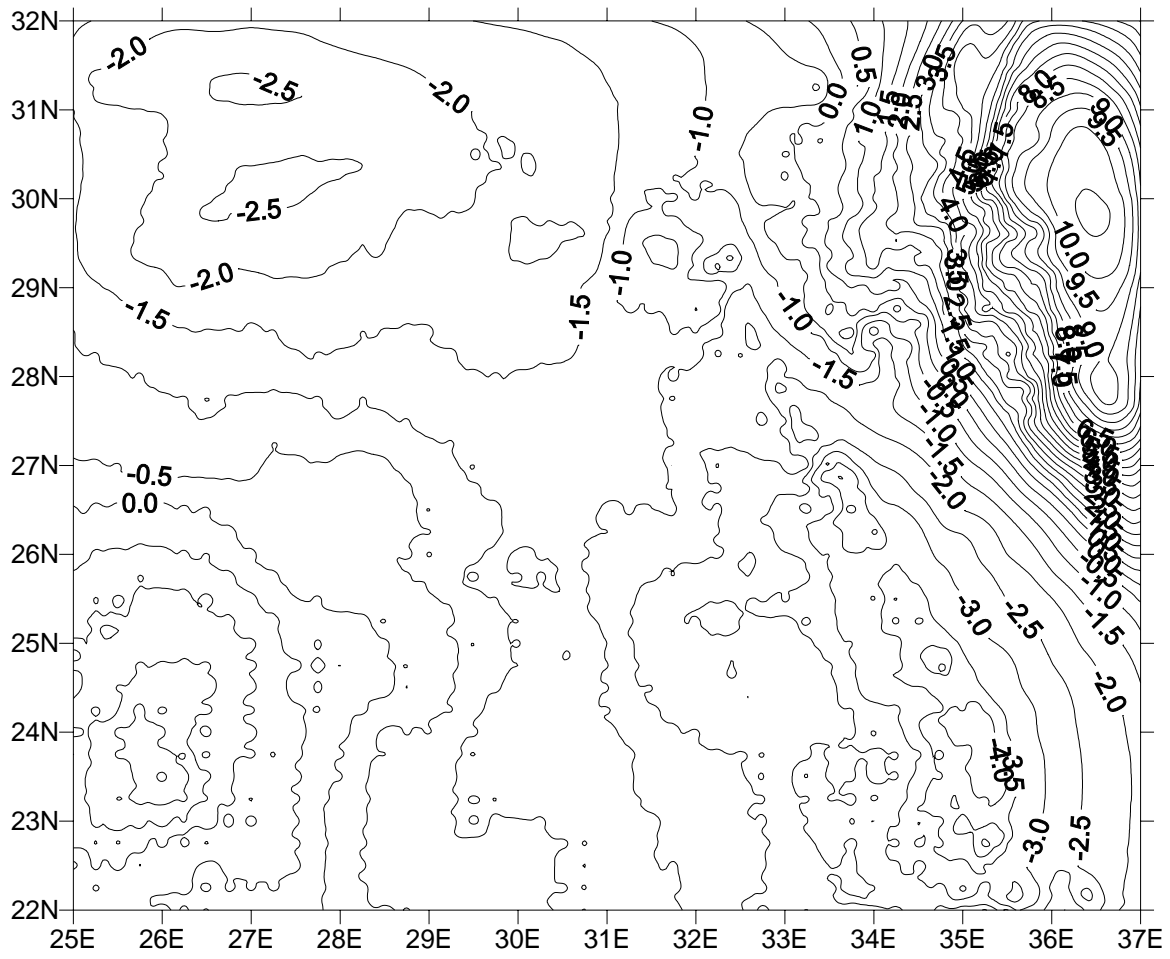

Figure 6-16

Differences between EGY-G2 and EGY-G3 geoid solutions

Table 6-4

Statistics of the differences between EGY-G3 and EGY-G2 geoid solutions, as expressing the effect of both global and local DEM models

Item	Minimum	Maximum	Average	RMS
Global DEM	-132	1829	308	249
Local DEM	-122	2723	240	205
Local - Global DEM	-997	989	-60	220
EGY-G3 Geoid	6.39	22.94	15.20	2.99
(EGY-G 3) - (EGY-G2)	-4.86	10.47	-0.50	2.71
EGY-G3 – OSU91A	-9.74	10.56	0.39	2.94

6.3.1.4 Geoid Solution 4 (EGY-G4): A gravimetric geoid using all available gravity data being corrected for the terrain effect, and a local DEM

The previous three gravimetric geoid solutions utilize gravity data that are not corrected for the topography effects. However, the fourth geoid solution, presented here, applies the terrain correction to the observed point gravity anomaly used data. By this process, one can investigate the effect of terrain corrected gravity data on the final results of the produced geoid solution.

A program for computing the terrain correction on gravimetric quantities, called TC, was used to calculate these corrections at the 240 gravity stations. The local DEM was used in the computation. The TC program, provided by Prof. Hans Sunkel [1998], was originally developed by Rene

Forsberg, in 1983 and modified later by Hans Sunkel. Slight modifications have been carried out by the author, in order to run the program under the DOS operating system on a PC platform.

The computed terrain corrections to free-air gravity anomalies, are summarized in Table 6-5. From this table, it is evident that, the terrain corrections range from 0.05 to 7.69 mGal with an average value of 2.40 mGal and RMS of 1.28 mGal. From the obtained results, it can be concluded also that, the terrain corrections to the gravity (or gravity anomaly) value is correlated with elevations around the computation point.

Table 6-5

Statistics of terrain corrections

From	To	Percentage of terrain corrections
< 1 mGal		15 %
1.0	2.0	21 %
2.0	3.0	35 %
3.0	4.0	15 %
4.0	5.0	12 %
5.0	6.0	1 %
6.0	7.0	1 %
> 7.0 mGal		0.5 %
Minimum Terrain Correction		0.05 mGal
Maximum Terrain Correction		7.69 mGal
Average Terrain Correction		2.40 mGal
RMS of Terrain Correction		1.28 mGal

Using the same set of terrestrial gravity measurements after being corrected for the terrain effects, a new geoid solution EGY-G4, was produced. The local DEM model and OSU91A geopotential model were applied, again. The obtained geoid EGY-G4, is depicted in Fig. 6-17, and whose statistics are given in Table 6-6. From this figure and table, it is clear that the geoidal undulation of this geoid solution has geoidal heights range from 6.37 m to 22.94 m with an average value of 15.21 m and RMS of 2.99 m.

A comparison has been made between the last two geoid solutions, namely EGY-G4 and EGY-G3 solutions, in order to investigate the effect of applying the terrain corrections to the utilized 240 gravity stations, on the final resulted geoid solution. The differences between the two geoid solutions are illustrated in Fig. 6-18 and summarized in Table 6-6. From this figure and table, it can be noticed that, the differences between the two solutions in undulation, range from -0.12 m to 0.52 m with an average of 0.008 m and RMS of 0.005 m.

From the above obtained results, it can be concluded that there are insignificant differences between the geoid solutions with or without gravity data corrected for the terrain effects. In fact, the range of such differences is very small, about half a meter, particularly in mountainous areas, and their mean value is almost zero. In other words, for gravimetric geoid computations in Egypt, with a local DEM, it is not necessary to correct the used point gravity values for the terrain effects. This could be the case since most of the topography of the Egyptian territory, is more or less modest, except over small mountainous areas.

Table 6-6

Statistics of the differences between EGY-G3 and EGY-G4 geoid solutions, as expressing the effect of applying the terrain correction to the observed gravity values on the resulted geoid

Item	Minimum	Maximum	Average	RMS
EGY-G4 Geoid	6.37	22.94	15.21	2.99
EGY-G3 Geoid	6.39	22.94	15.20	2.99
(EGY-G 4) - (EGY-G3)	-0.12	0.52	0.008	0.005
EGY-G4 – OSU91A	-9.76	10.30	0.39	2.93

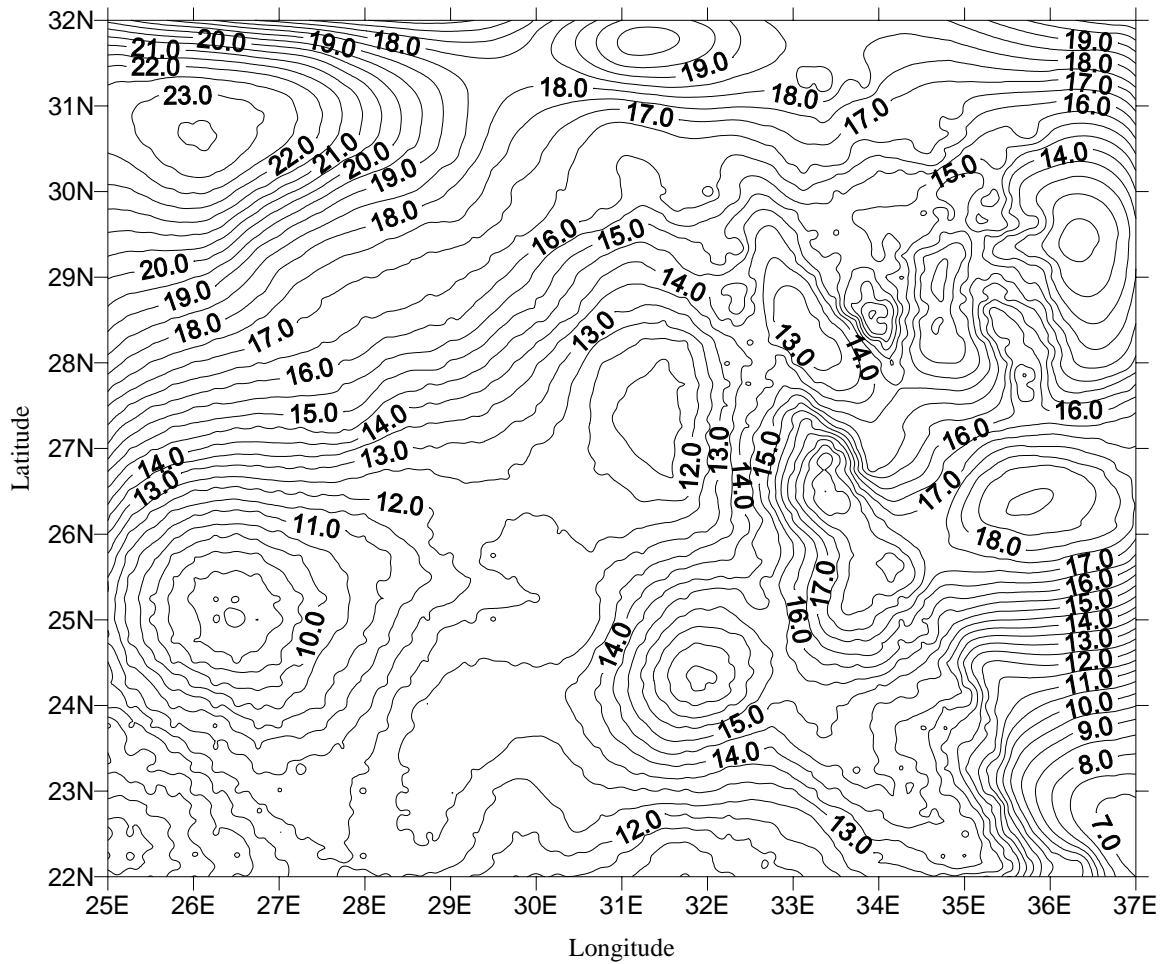

Figure 6-17
The EGY-G4 geoid solution
(using all available terrain-corrected gravity data, and a local DEM)

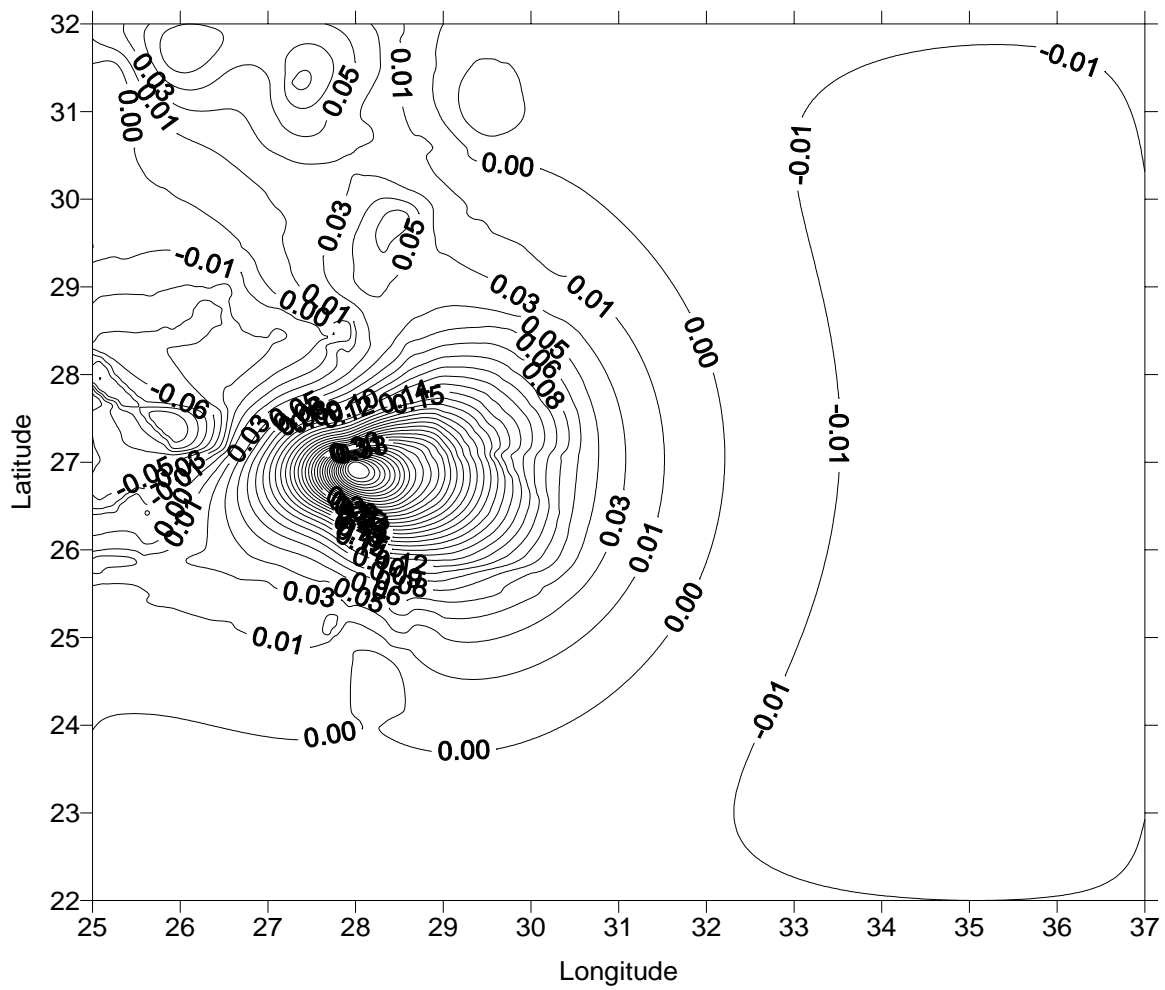

Figure 6-18

Differences between EGY-G4 and EGY-G3 geoid solutions

6.3.2 Developing A GPS-Based Geoid for Egypt “ EGY-G5”

The second category of the developed geoid models for Egypt is a geoid solution obtained from the observed orthometric and ellipsoidal heights of known stations. The following sub-sections describe the data used and the obtained geoid model.

6.3.2.1 The Available GPS-Based Geoid Undulation Data Sets

A total of 95 precise GPS stations have been collected. They are divided into three sets (Fig. 6-19). The first set contains 17 stations of the Egyptian National High Accuracy Reference Network (HARN) observed by the Egyptian Survey Authority to form the New Egyptian Datum 1995 (NED-95). In this network, the GPS observations were tied to some of the International Geodetic Stations (IGS) reference system. It should be mentioned that, the HARN network consists of 30 stations, but 13 stations (located in remote areas) have no observed orthometric heights and consequently, no undulations could be obtained for these stations. The second set of the available data contains 52 stations observed by the Survey Research Institute, which are also included in the ENGSN97 gravity network. Such stations were tied to the nearest available HARN station, in an approximate manner, while observing each gravity loop. The third set consists of 26 stations of the first-order GPS network in the Eastern desert observed by Finnmap [Finnmap, 1989], which are based on referencing to some of the Egyptian first-order triangulation network, based on precise point positioning of some common stations.

6.3.2.2 Integration of different GPS undulation data sets into the same reference system

Before using the different three sets of GPS stations observed by the above mentioned three different organizations, the common stations were analyzed. For example, 4 common stations (E7, A6, A5, and T2) are existing between the ESA and FINNMAP data sets. The differences in the geoidal undulations, over those common stations, reach about 10 meters. The same situation exist between ESA and SRI data sets, but with much smaller differences. These differences, between the resulted undulations from the three different GPS data sets, could be expected due to the different instrumentation, observing and processing techniques, as well as the different coordinates frames. It is believed that the HARN GPS network is the most precise GPS framework in Egypt because of the precise instruments used, the use of precise satellite ephemerides, the connection to the IGS Stations, and the utilization of accurate processing and adjustment software . Therefore, it was decided to transform both the SRI and FINNMAP data sets to the HARN reference frame, in order to combine all the available GPS stations in a unique datum.

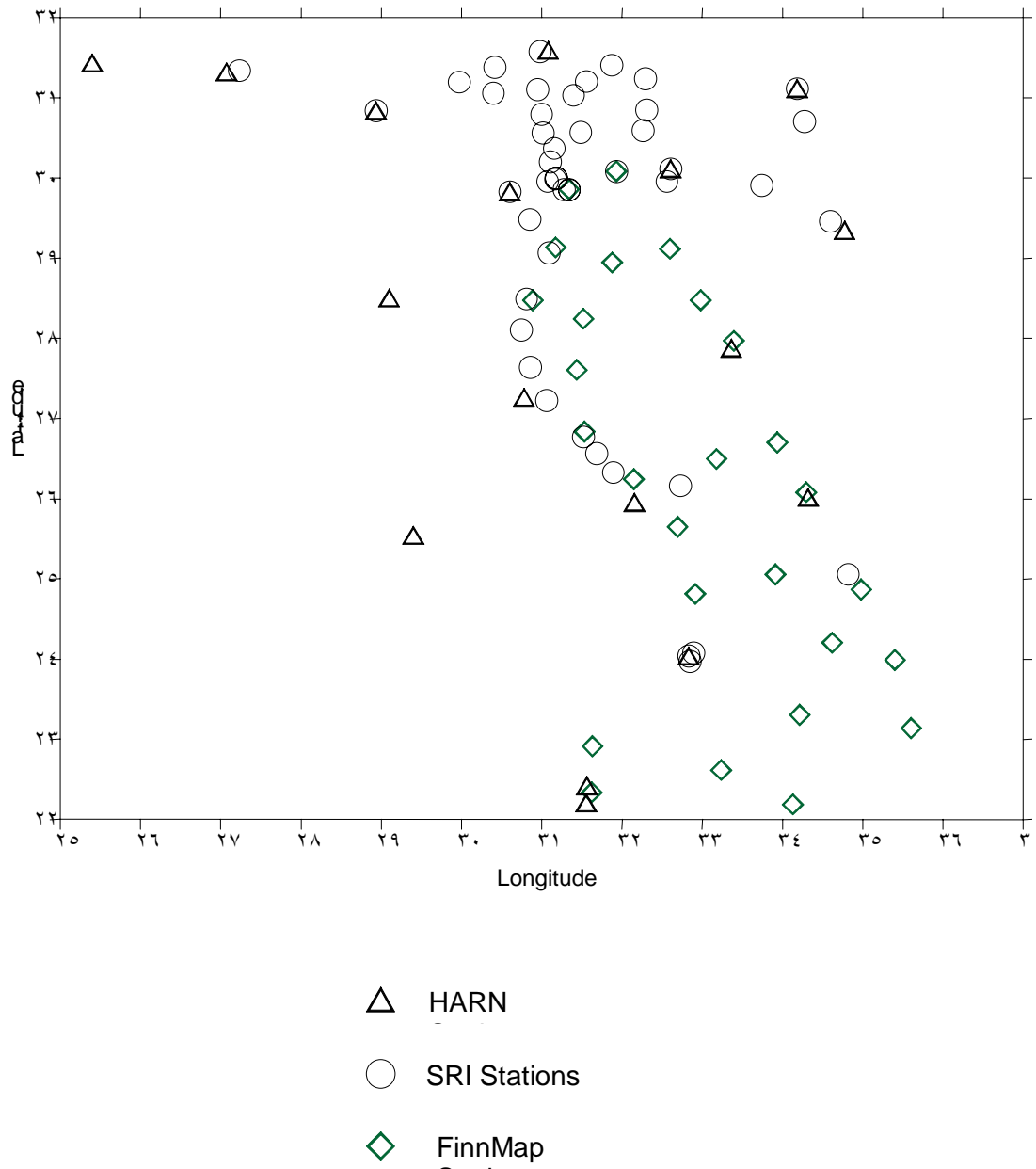

Figure 6-19
The available GPS stations in Egypt

Several fitting models have been applied to transform the FINNMAP data set to the HARN reference system. Some of those methods depend mainly on the distance (S) between the computation point and the central position among the existing common stations between the two system. The other fitting methods depend on the geodetic position (ϕ, λ) of the computation point. Five of these methods are investigated here, which are:

- * A linear model, which is a first-order polynomial as a function of the distance from the network origin,
- * A second-order polynomial as a function of the distance from the network origin,
- * A third-order polynomial as a as a function of the distance from the network origin, and
- * A linear model, which is a first-order polynomial as a function of the latitude and longitude,
- * A non-linear model, which is a second-order polynomial as a function of the latitude and longitude.

(1) The first method: A linear model, which is a first-order polynomial as a function of the distance from the network origin,

$$\Delta N = f(S) = A_1 + A_2 * S \quad (6-12)$$

where,

ΔN is the difference between the two values of geoid undulations from two different data sets

A_1 and A_2 are two unknown coefficients to be determined

(2) The Second method: A second-order polynomial as a function of the distance from the network origin:

$$\Delta N = f(S) = A_1 + A_2 * S + A_3 * S^2 \quad (6-13)$$

where,

A_1 , A_2 , and A_3 are three unknown coefficients to be determined

(3) The third method: A third-order polynomial as a function of the distance from the network origin:

$$\Delta N = f(S) = A_1 + A_2 * S + A_3 * S^2 + A_4 * S^3 \quad (6-14)$$

where,

A_1 , A_2 , A_3 and A_4 are unknown coefficients to be determined

(4) The fourth method: A linear model, which is a first-order polynomial as a function of the latitude and longitude:

$$\Delta N = f(\phi, \lambda) = A_1 + A_2 * \phi + A_3 * \lambda \quad (6-15)$$

where,

A_1 , A_2 , and A_3 are three unknown coefficients to be determined

ϕ and λ are the geodetic latitude and longitude of the station.

(5) The fifth method: A non-linear model, which is a second-order polynomial as a function of the latitude and longitude:

$$\Delta N = f(\phi, \lambda) = A_1 + A_2 * \cos \phi \cos \lambda + A_3 * \cos \phi \sin \lambda + A_4 * \sin \phi \quad (6-16)$$

where,

A_1, A_2, A_3 and A_4 are unknown coefficients to be determined

This model is suggested by Heiskanen and Moritz [1967, pp. 213] and applied by Shaker et al [1997a] recently in a similar application.

Firstly, the common undulation differences between the two systems, at the four common stations, are utilized to obtain the best estimates for the unknown coefficients in each individual model for the sought transformation. The statistics of the obtained results, for the undulation differences, as produced by the five transformation models, at the remaining 26 FINNMAP GPS stations, to be transformed to the HARN reference, are summarized in Table 6-7.

Table 6-7
Statistics of the undulation differences between the FINNMAP
results and the corresponding HARN reference values
for the five investigated transformation models

Item	Method	Method	Method	Method	Method
	1	2	3	4	5
common stations	4	4	4	4	4
Unknown coefficients	2	3	4	3	4
Minimum ΔN at 26 st.	-3.84	-3.28	-3.90	-4.04	-4.23
Maximum ΔN at 26 st.	5.99	5.67	6.12	5.88	5.92
Average ΔN at 26 st.	3.12	2.94	3.26	3.17	3.33
RMS of ΔN at 26 st.	2.45	2.37	2.61	2.76	2.88

From table 6-7, it can be noticed that, the second model (eq. 6-13), provides the best fitting model for transforming the FINNMAP undulation to the corresponding HARN values, as it gives the least RMS of such resulted undulation differences. Consequently, the resulted undulation differences from this model, in the HARN system, will be adopted for GPS geoid determination, by adding those differences to the FINNMAP known undulations at the 26 FINNMAP stations, which make all the obtained undulations are relative to the same HARN reference frame.

Concerning the SRI resulted undulations, they are referenced already to the HARN system, in an approximate fashion as mentioned before.

6.3.2.3 The obtained results of the integrated GPS geoid (EGY-G5)

The above three data sets, as related to the same HARN system, are used to generate a geoid contour map, generated from a 5'x5' interpolated grided undulations, as represented by Fig. 6-20, which is called here the fifth geoid solution EGY-G5. From this figure, it can be found that the minimum and maximum values are 7.65 and 21.36 m respectively with an average value of 14.00 m and RMS of 3.53 m. Following the same procedure of comparing different geoid solutions, the obtained GPS geoid solution EGY-G5, will be compared here with the last previous gravimetric geoid solution EGY-G4. Table 6-8 summarizes the statistics of the resulted undulation differences, between the two solutions, which are graphically represented by Fig. 6-21. From this figure and table, it can be seen that, those differences range between -9.31 m and 7.38 m, with an average value of -2.16 m and RMS equals 2.23 m. Of course, such differences should be expected, due to the different types of geodetic data, as well as the techniques used for collecting these data. Although, the resulted differences are relatively acceptable, the gravimetric geoid EGY-G4 seems to be more precise than the GPS geoid EGY-G5. However, the later GPS data and results, should not be neglected as an important piece of information, which suggests the combination of both gravimetric and GPS geoid solution in the same combined solution, as will be performed in the next section.

Table 6-8
Statistics of the differences between the GPS geoid EGY-G5
and the gravimetric geoid EGY-G4

Item	Minimum	Maximum	Average	RMS
EGY-G4 Geoid	6.37	22.94	15.21	2.99
EGY-G5 Geoid	7.65	21.36	14.00	3.53
(EGY-G 5) - (EGY-G4)	-9.31	7.38	-2.16	2.23

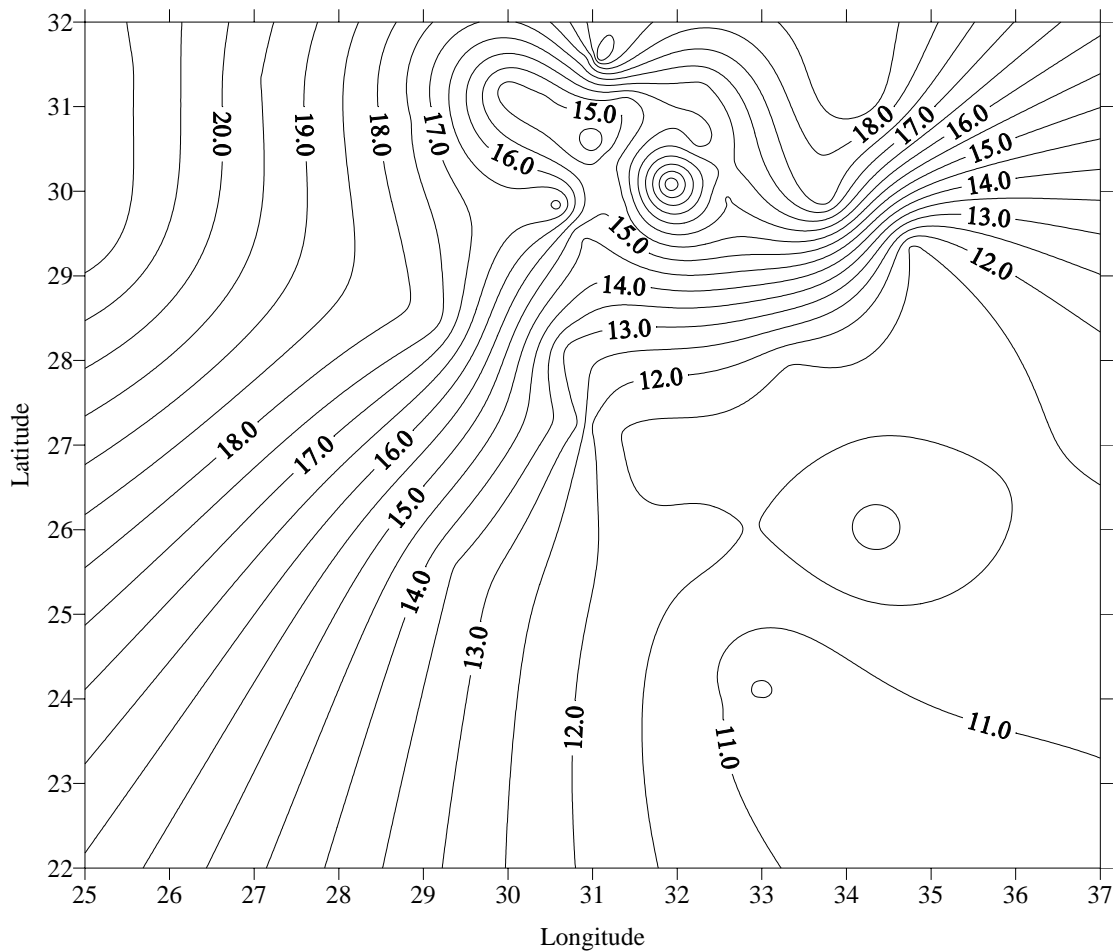

Figure 6-20
GPS-Based EGY-G5 Geoid Solution

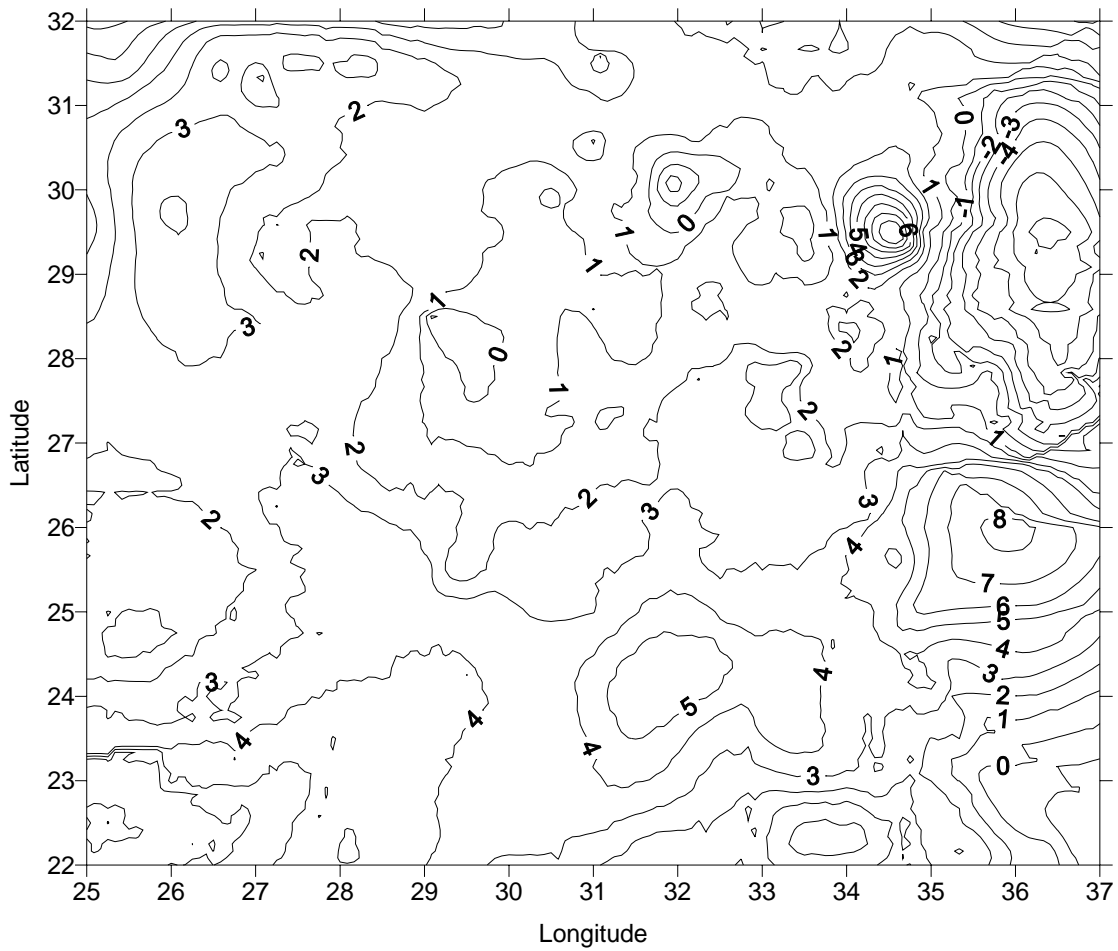

Figure 6-21

**Differences Between the GPS Geoid EGY-G5
and the Gravimetric Geoid EGY-G4**

6.3.3 Developing Combined Gravimetric/GPS Geoids for Egypt

The issue of combining gravity and GPS data in developing high-precision geoid models gains a lot of attention in the last few years. Several research studies have handled this point (e.g. Shaker et al, 1997b, Veronneau, 1996, and Denker,et al, 1996) So, the third category of the geoids developed for Egypt is a set of combined solutions based on the integration of gravimetric undulations and GPS-based undulations.

Recall from section 6-3-1 that, a total of 240 gravity stations were used in generating the obtained gravimetric geoid solutions, particularly as produced by the fourth solution EGY-G4. Similarly, from section 6-3-2, a total of 95 GPS stations, were employed to generate the GPS geoid, as a result of the solution EGY-G5. The examination of figures 6-11 and 6-19, illustrating the distribution of the gravity and GPS stations, respectively, indicates that, there are 45 common stations between both types of data. The idea here, is to consider, the GPS-derived undulations to be the best accurate reference, for the sought combined gravity/GPS geoid. In other words, it will be required here to transform the gravimetrically-determined undulations, from solution EGY-G4, to the corresponding values expressed into the GPS reference geoid solution EGY-G5. The different fitting models presented in section (6.3.2.2) are employed, again, to test which transformation method gives best results.

The forty five common stations, between gravity and GPS systems, have been used, to determine the unknown coefficients of theses five tested models. The statistics of the obtained geoid undulation differences, computed

at the remaining 195 stations of the gravity network, are summarized in Table 6-9. From this table, it can be concluded that the second transformation model (equation 6-13), again, produces the best fitting results to the original gravimetric undulations, and hence, is adopted here.

Table 6-9
Statistics of the undulation differences between the Gravimetric
Undulations and the corresponding GPS reference values
for the five investigated transformation models

Item	Method 1	Method 2	Method 3	Method 4	Method 5
Minimum ΔN	1.21	1.05	1.25	1.39	1.52
Maximum ΔN	4.07	3.93	4.19	4.27	4.38
Average ΔN	2.01	1.81	2.18	2.30	2.54
RMS of ΔN	2.12	1.99	2.10	2.12	2.16

The computed geoid undulation differences, from the second transformation model, are added to the known gravimetric undulations at the 195 gravity stations, to make them, along with the 95 known GPS undulations, to be in the same GPS datum. Note that, the adopted gravimetric geoid for the combination with GPS, is that one produced by solution EGY-G4. The resulting undulations, in the GPS system, were used to establish a 5'x5' interpolated grided undulations, from which the obtained combined geoid for Egypt, as depicted in Fig. 6-22, is generated, and will be named here as the

sixth geoid solution EGY-G6. The statistics of these undulations of the combined gravity/GPS geoid, are summarized in Table 6-10. From this figure and table, one can find that the combined geoid undulations range between 7.22 m and 22.55 m, with an average value of 15.31 m and RMS equals 3.1 m.

Table 6-10

Statistics of the Resulted Undulations From the Combined Gravity/GPS Geoid EGY-G6

Minimum Undulation (m)	7.22
Maximum Undulation (m)	22.55
Average Undulation (m)	15.31
RMS of Undulation (m)	3.10

Again, the comparison between the last two solutions, namely the pure GPS geoid EGY-G5 and the gravity/GPS combined geoid EGY-G6, can be made, similar to the previously performed comparisons. The differences between the two solutions are presented in Fig. 6-23, and their statistics are summarized in Table 6-11. From this figure and table, it can be found that the undulation differences between the two geoid solutions range between -6.36 m and 8.24 m, with an average value of -0.91 m and RMS equals 2.80 m.

Table 6-11
Statistics of the differences between the pure GPS geoid EGY-G5
and the combined gravity/GPS geoid EGY-G6

Item	Minimum	Maximum	Average	RMS
EGY-G6 Geoid	7.22	22.55	15.31	3.10
EGY-G5 Geoid	7.65	21.36	14.00	3.53
(EGY-G 6) - (EGY-G5)	-6.36	8.24	-0.91	2.80

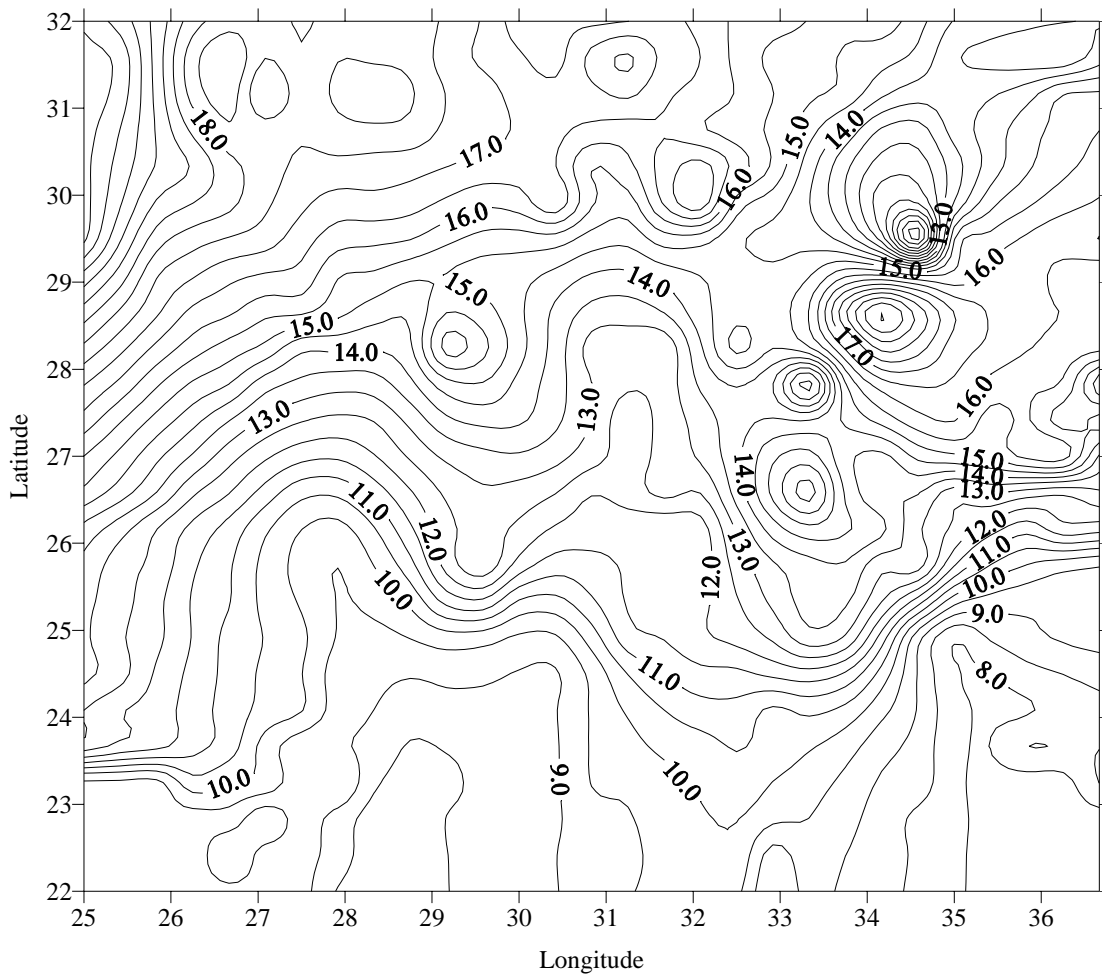

Figure 6-22
The Combined Gravity/GPS Geoid Solution EGY-G6

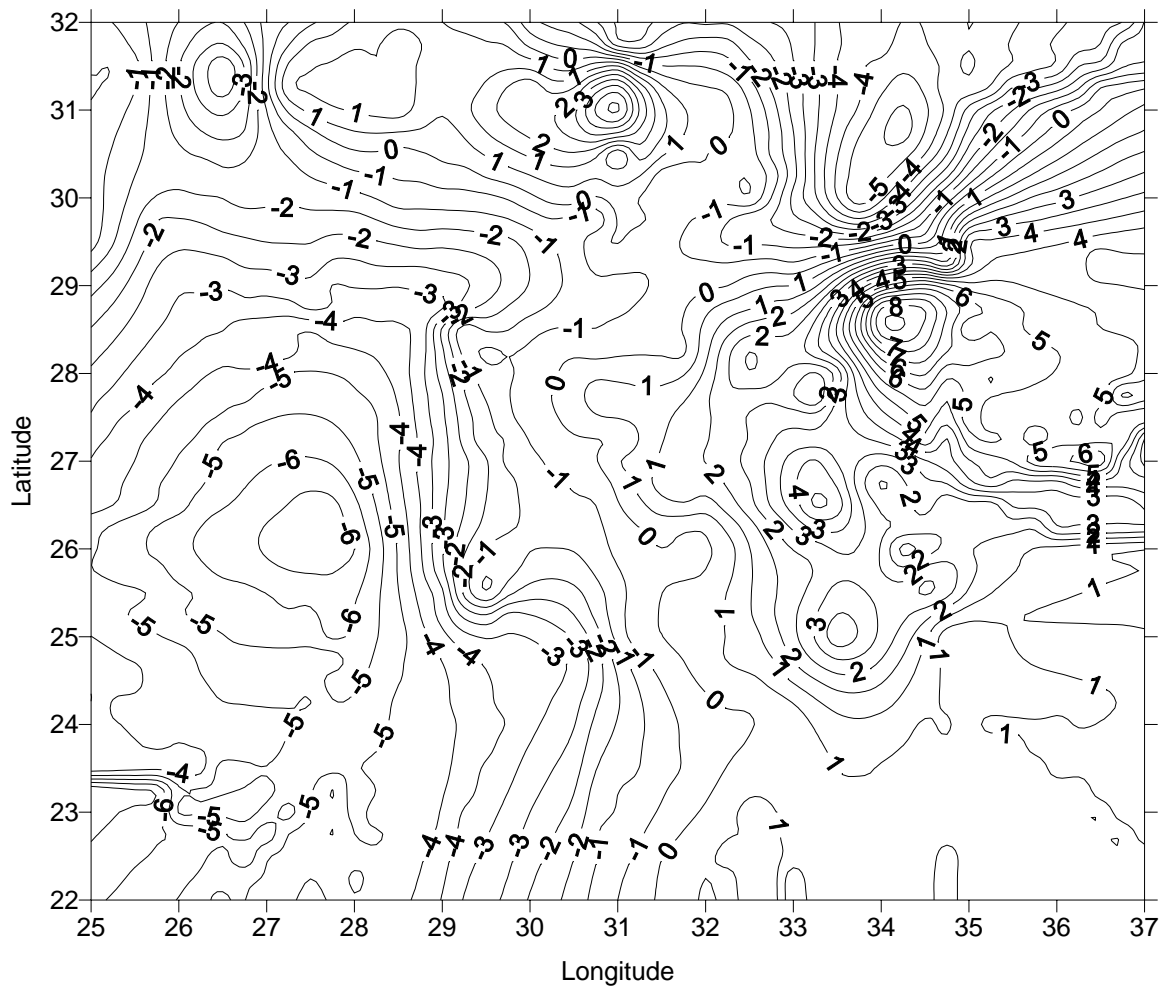

Figure 6-23

Differences Between EGY-G6 and EGY-G5 Geoid Solutions

The above results indicate that, the combined gravity/GPS geoid is more reliable than the pure GPS geoid. In addition, the combined geoid has approximately equivalent precision similar to the pure gravimetric geoid. However, since the GPS geoid is depending upon undulations, determined at discrete points using GPS technique, and does have minimum error propagation scheme, as compared to the gravimetric geoid, which depends upon surface integration of correlated gravity anomalies, it will be expected that the it will be more accurate. Again, as mentioned before, the combination between different sources of geodetic data, which are gravity and satellite positions in our case here, will lead to more accurate and representative results. Accordingly, the developed combined gravity/GPS geoid, can be considered here as the final recent geoid solution for Egypt, and will be named here as SRI-GEOID98.

6.4 Essential characteristics of the final geoid model for EGYPT

SRI-GEOID98

Recall from the previous section that, six geoid solutions For Egypt have been produced in this research study, as summarized in Table 6-12. The different used data types, different digital elevation models, and different criteria lead to these various geoid solutions.

Table 6-12
Summary of the used data information for the different
developed six geoid solutions for Egypt

No	Only New ENGSN97 Gravity Data	New & Old Gravity Data	Global DEM	Local DEM	TC	GPS Only	GPS + Gravity Data
1	X		X				
2		X	X				
3		X		X			
4		X		X	X		
5						X	
6		X		X	X		X

It has been concluded above that, the sixth geoid solution EGY-G6 will be the most precise geoid model for Egypt based on the combination between the available gravity and GPS positioning information. This geoid model, called here as the SRI-GEOID98, contains GPS-based geoid undulations in a wide distance-separation and incorporates high-precision gravity-based geoid undulations, at more densified stations. The data used in developing this geoid model are the most-precise geodetic data available in the time being in Egypt especially the HARN-95 GPS net and the ENGSN97 gravity net. Another merit of the SRI-GEOID98 geoid model is that it takes advantages of utilizing a local digital elevation model even though its density is not enough, for precise geoid determination. The SRI-GEOID98 geoid model has geoid

undulations values ranging from 7.22 m to 22.55 m with the mean of 15.31 m and RMS equals 3.10.

Recall from section 5-5 that, both free-air and Bouguer gravity anomaly contour maps, were produced using the gravity information known at the 150 stations of the ENGSN97 gravity network (Fig. 5-6 and 5-7). Such maps are re-produced here again, however, using the known gravity information at the available 240 gravity stations, as employed for gravimetric geoid solutions (from the second to the fourth solutions). The obtained results are depicted in Fig. 6-24 and 6-25, for the free-air and Bouguer gravity anomalies, respectively. In addition, the gravimetric geoid computations of the fourth geoid solution EGY-G4, have been extended to the computations of gravimetric principle components of the deflection of the vertical, namely the meridional component ξ , and the prime-vertical component η , at the 240 used gravity stations, using the same software developed by Milbert [1997]. From such results, 5'x5' interpolated grided deflection components are produced for the purpose of generating the corresponding contour maps, illustrated in Fig. 6-26 and 6-27.

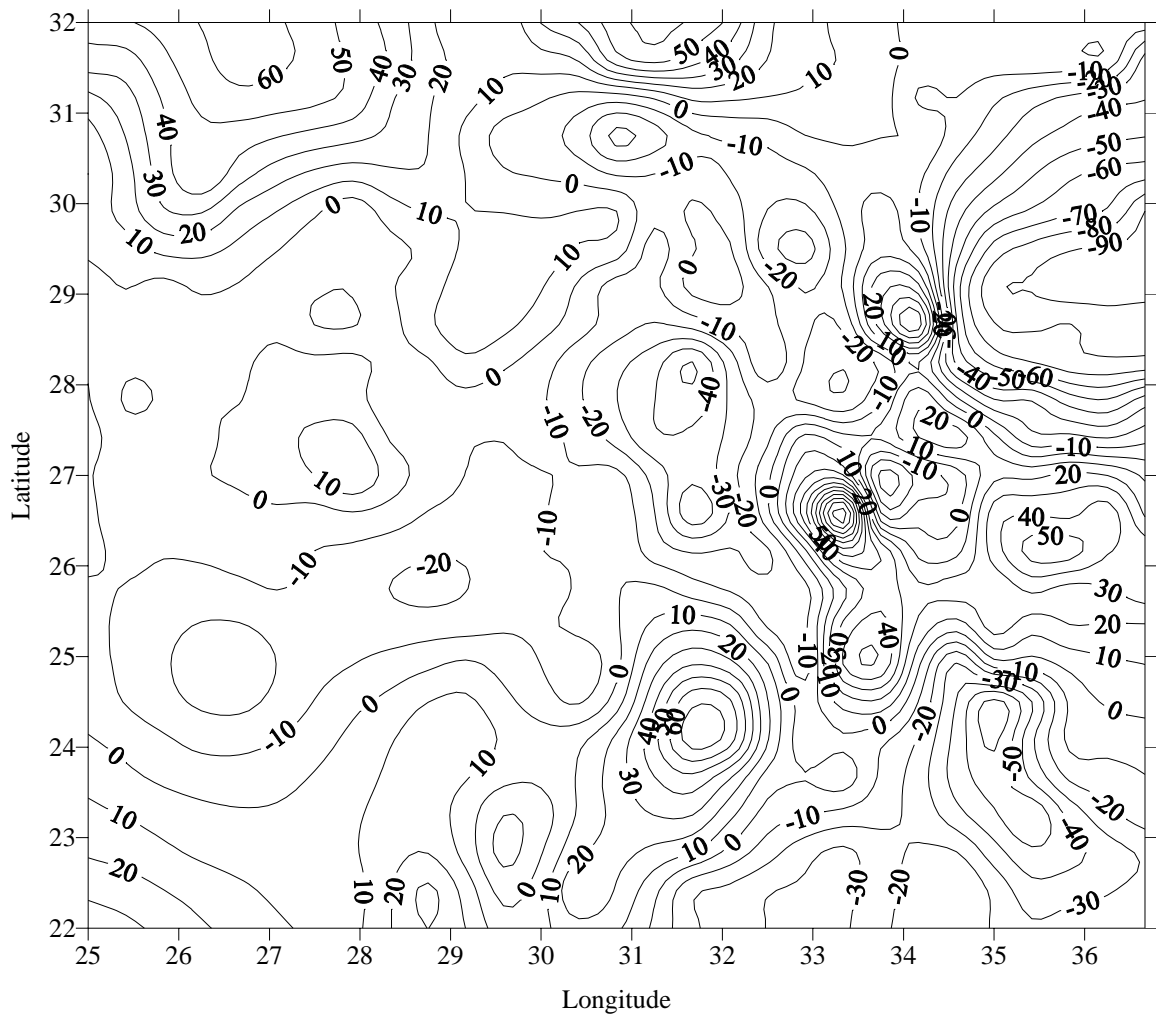

Figure 6-24

Obtained Updated Free-Air Gravity Anomaly Map For Egypt

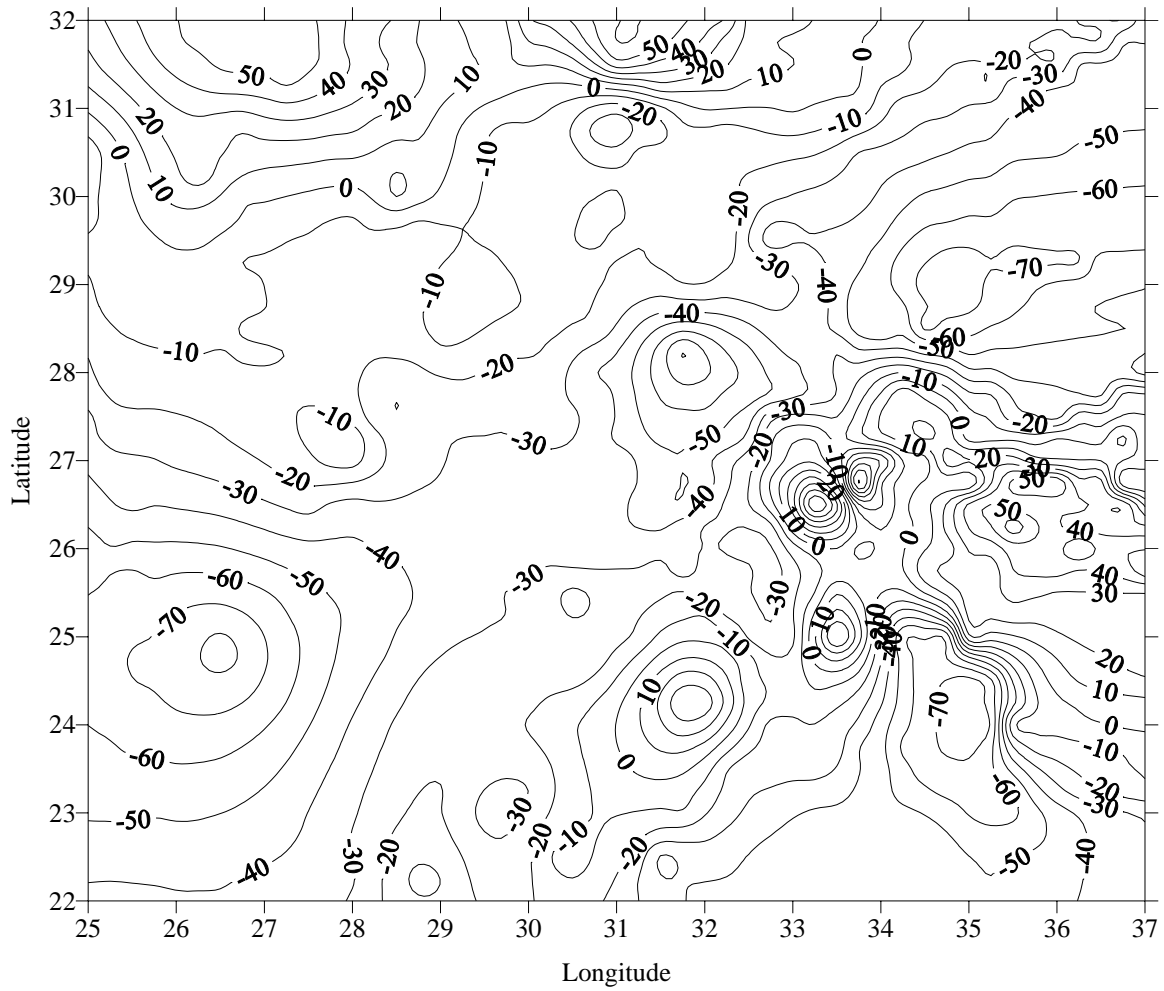

Figure 6-25

Obtained Updated Bouguer Gravity Anomaly Map For Egypt

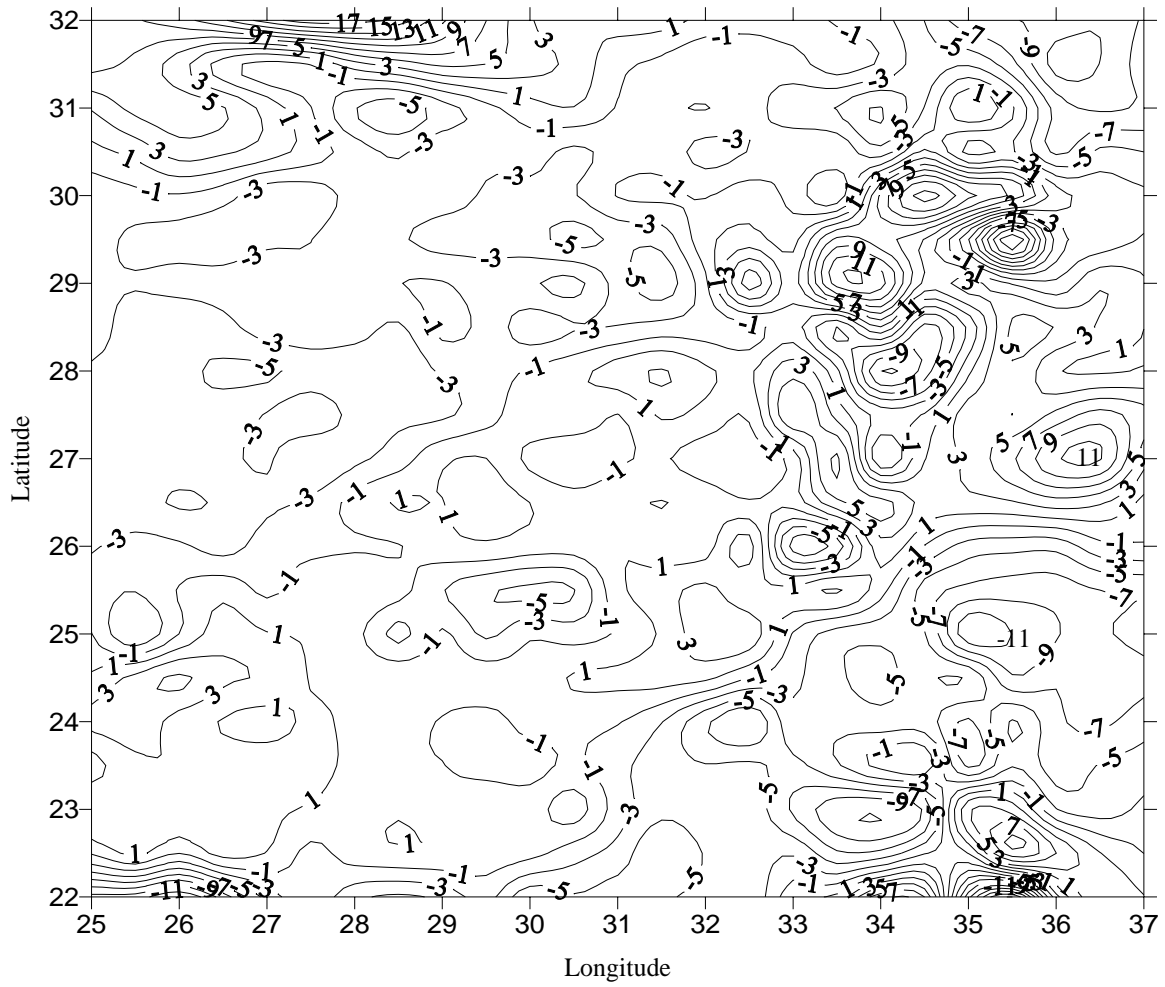

Figure 6-26

Resulted Meridian Deflection of the Vertical Map For Egypt

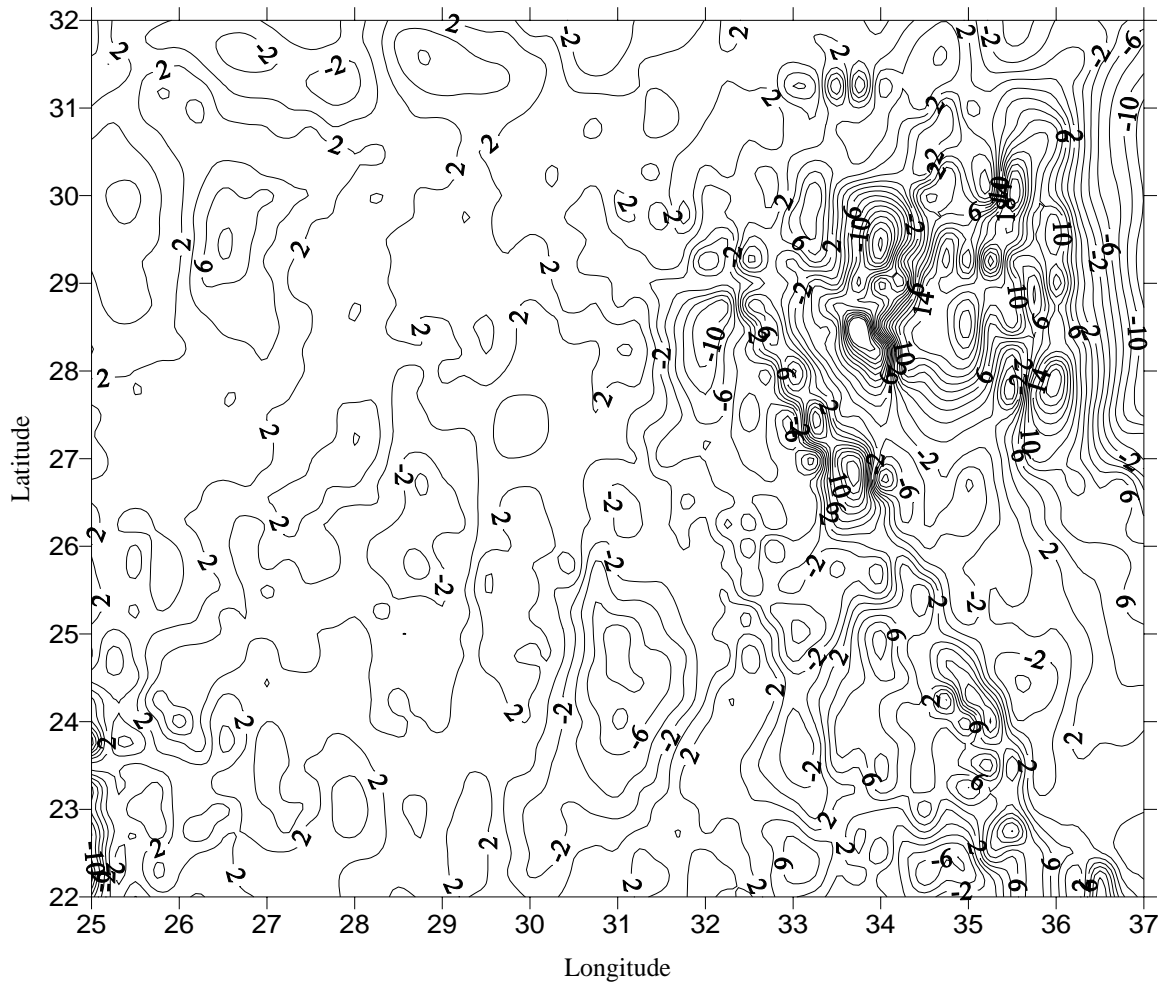

Figure 6-27

Resulted Prime Vertical Deflection of the Vertical Map For Egypt

The statistics of the all generated anomalous gravity field parameters, which are expressed in terms of gravity anomalies, geoid undulations, and the principle components of the deflection of the vertical, which are the main findings of the SRI-GEOID98 developed final geoid model, are summarized in Table 6-13. From Fig. 6-22, 6-23, 6-24, 6-25, 6-26, and 6-27, and Table 6-13, one can visualize the following essential information for the final developed geoid model for Egypt, SRI-GEOID98:

- (1) The SRI-GEOID98 geoid model has geoid undulations values ranging from 7.22 m to 22.55 m with the mean of 15.31 m and RMS equals 3.10.
- (2) For the meridian component, the minimum and maximum values have found to be $-23.55''$ and $24.73''$ with the average value of $-1.11''$ and RMS equals $4.35''$.
- (3) The prime vertical component ranges from $-36.16''$ to $26.26''$ with an average value of $1.02''$ and RMS equals $4.57''$.
- (4) The free-air gravity anomaly ranges from -122.42 mGal to 128.65 mGal with an average value of -3.21 mGal and RMS equals 28.55 mGal.
- (5) The Bouguer gravity anomaly ranges from -130.97 mGal to 81.76 mGal with an average value of -21.77 mGal and RMS equals 28.38 mGal.

Table 6-13

Statistics of the SRI-GEOID98 anomalous gravity field parameters

Items	Minimum	Maximum	Mean	RMS
Free-Air Gravity Anomalies (mGal)	-122.42	128.65	-3.21	28.55
Bouguer Gravity Anomalies (mGal)	-130.97	81.76	-21.77	28.38
Geoid Undulations (m)	7.22	22.55	15.31	3.10
Meridional Deflections (")	-23.55	24.73	-1.11	4.35
Prim-Vertical Deflections (")	-36.16	26.26	1.02	4.57

**6.5 Performance of SRI-GEOID98 geoid model over the purely
GPS-determined undulations**

In order to validate the performance of the final combined gravity/GPS geoid solution SRI-GEOID98, with pure GPS-determined undulations, the geoid undulations obtained from both geoid solutions can be compared over some GPS stations. In our case here, there are fifteen GPS stations, whose locations are depicted in Figure 6-28, established by the SRI for some other purposes. For those fifteen stations, the orthometric heights are also observed, beside the known geodetic heights as obtained from satellite positioning. Taking the pure GPS undulations as the reference system of comparison, the differences between those undulations and the corresponding values from the SRI-GEOID98, can be evaluated. Those differences were found to be range

from a minimum of -1.69 m to a maximum of -0.48 m with an average of -0.41 and RMS equals 0.79.

Of course, the discrepancies between the two geoids, can be attributed to different factors:

- * Systematic errors in the levelling network,
- * Long wavelength errors in the geopotential models, and
- * Data quality, distribution and density.

When considering the GPS-based undulations to be the most accurate, and hence, are taken as the reference of comparison. From the obtained results, it could be said that, the mean and the RMS values of the differences between the developed SRI-GEOID98 and the pure GPS-based undulations are promising. Accordingly, it can be expected that the differences could be greatly decreased, when having more additional precise GPS undulations (especially in the west desert), to be incorporated in a similar integrated geoid solution following the same development procedures, as already performed here.

Similar results have been reported in different international studies. Denker et al. [1996], use similar procedures for the integration of gravimetric and GPS-based undulations and found that the RMS of undulation differences equals 0.16 m over the long European GPS traverse. In Canada, the RMS of the undulation differences, between a combined gravity/GPS geoid model, after using a four-parameter transformation model, and GPS-based geoid, is found to be 0.15 m [Veronneau, 1996]. It can be seen that, the above discussed two examples of the integrated gravity/GPS geoids, in Europe and Canada, seem to be more precise than the corresponding developed SRI-GEOID98. Of

course, as mentioned above, this could be due to the good quality, number, and distribution of the used data points for both gravity and GPS networks, in the former case.

6.6 A comparison between SRI-GEOID98 and some previously-determined local geoid solutions in Egypt

Several geoid solutions have been developed for Egypt in the last decades. A comparison of these geoids, and the one developed in the present research study, will be given. Alnaggar [1986] used gravity, Doppler, and astronomic data to produce a geoid relative to the WGS-72 Doppler datum. El-Tokhey [1993] developed a geoid relative to GRS80 using gravity, astronomic, Doppler, and GPS data. El-Sagheer [1995] applied the FFT techniques using a global geopotential model combined with terrestrial gravity data and heights from a local DEM, which was used to predict free-air gravity anomalies in void areas. Shaker et al. [1997b] developed a combined geoid where two types of geoid undulations (gravimetric and GPS-derived) are integrated in a unique solution. Finally, the SRI-GEOID98, developed in the present study, is similar to the one presented by Shaker et al, however, with different gravity and GPS data number and distribution. The same holds true, for the other previously-determined geoid solutions. Table 6-14 presents a summary of the statistics between the obtained geoid undulations for the above listed five local geoids in Egypt

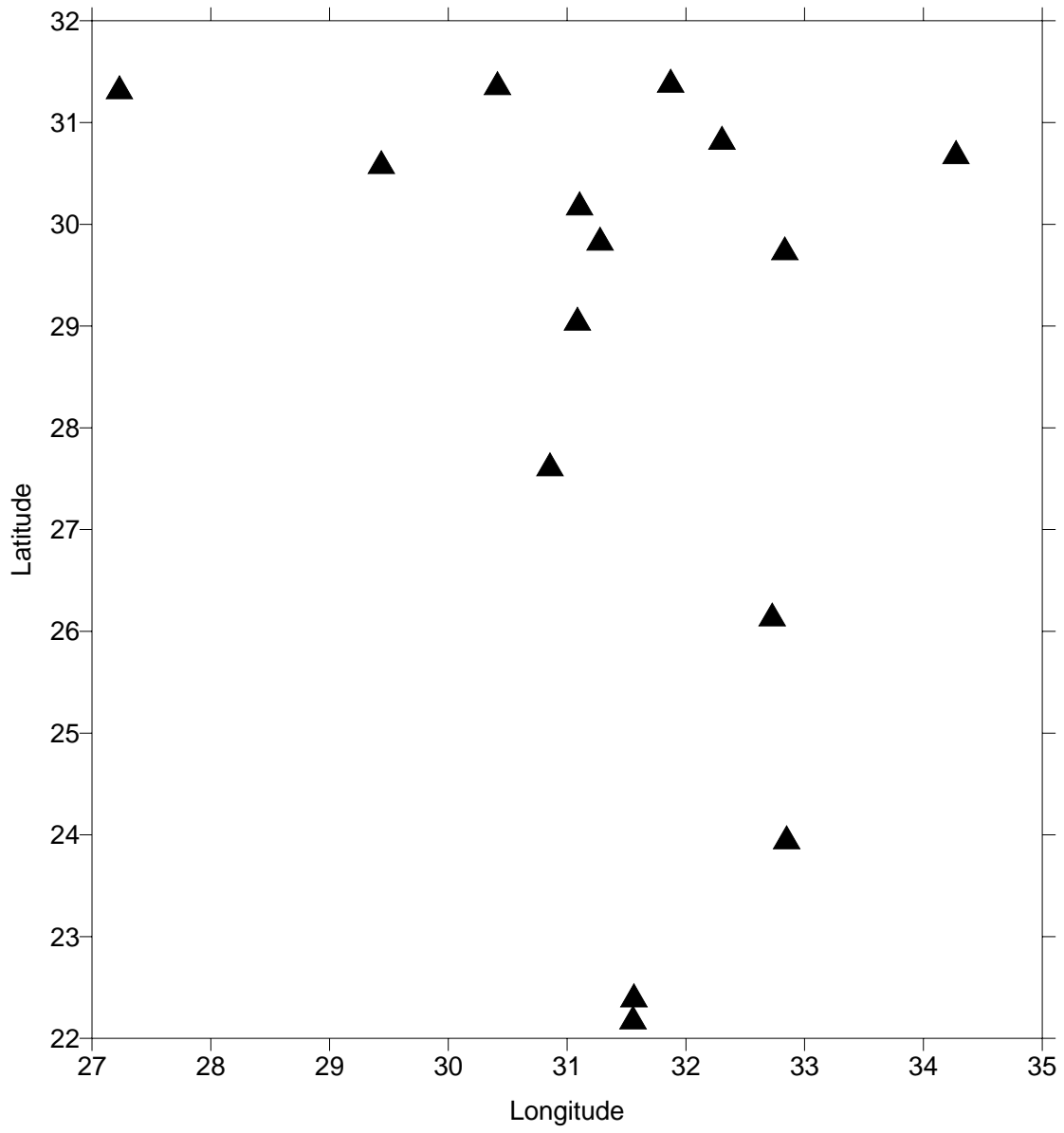

Figure 6-28

Locations of the GPS check points used

It is evident from table 6-14 that, the developed SRI-GEOID98 geoid solution gives least RMS, among the last four geoid solutions, which are determined relative to the WGS84 GPS datum. Note here that, the first geoid is relative to the WGS72 Doppler datum. Hence, SRI-GEOID98 may be considered as the best geoid model in hand that can be obtained from the available data in Egypt. Of course, as stated above, and as concluded from section 6-3 that, increasing the number and quality of the well-distributed precise gravity stations, as well as GPS positions, and integrating them into a unique combined geoid solution, will certainly lead to more reliable and enhanced geoid determination in Egypt. Such promising geoid, surly will cope with the recent and increasingly demanded geoid applications in Egypt, like for instance, the determination of orthometric heights from GPS-determined positions at remote areas in our country, provided that a precise geoid is available.

Table 6-14
Statistics of the previously and recently computed
local geoids in Egypt

Geoid Solution	Type of Geodetic Data	Minimum	maximum	Mean	RMS
Alnaggar 1986	Heterogeneous	7.47	22.32	16.47	3.3
El Tokhy 1993	Heterogeneous	13.03	35.00	23.14	5.21
El Sagheer 1995	Gravimetric + DEM	16.87	31.32	23.19	3.71
Shaker et al., 1997	Gravimetric + GPS	12.35	34.22	23.47	4.47
SRI-GEOID98	Gravimetric + GPS	7.22	22.55	15.31	3.10

Chapter 7

Summary, Conclusions, and Recommendations

Gravity control networks are needed to support several applications on a national and international scale. Gravity data find multiple use in several fields of geosciences. Local gravity field representations are required for establishing geodetic control networks in geodetic and engineering surveys. Accordingly, a recent and accurate gravity framework for Egypt has been established through the Egyptian National Gravity Standardization Network (ENGSN97). With a national homogeneous distribution and the utilization of precise instrumentation, the ENGSN97 serves as the national first-order gravity network for Egypt.

This research study focuses on all the procedures of data acquisition, processing, adjustment, and analyses of the ENGSN97 network. The main objectives of this dissertation are:

- (1) The study and analysis of some similar gravity networks on both national and international scales.
- (2) The study of relative gravimeters' performance especially the recent models of LaCoste and Romberge instruments used in the ENGSN97 network.
- (3) The development of processing and adjustment models that are capable of treating all types of observations schemes applied in the ENGSN97 network.
- (4) The development of computer programs that utilize the developed processing models in an effective manner on a PC configuration.
- (5) The utilization of statistical tests to increase the reliability of the observations in order to come up with precise and unique adjusted values of gravity for the ENGSN97 stations.

- (6) The development of recent combined geoid models for Egypt including the values of geoid undulations and the two components of the deflection of the vertical through the integration of gravimetric and GPS data, to be considered as one important and direct geodetic application for the established precise ENGSN97 gravity network, just as an example.

The basic items connected with design, and field measurements of the ENGSN97 network are discussed. Gravity processing models, used previously in adjusting some selected national and international gravity networks, are analyzed. Then, stipulated criteria for new proposed gravity processing models, comprising all different cases of observational schemes are chosen as follows:

- * The model serves two functions: processing gravimetric measurements, and perform least square adjustment to come up with the best linear un-biased estimates of the required quantities. This point could be a good advantage of the proposed model since it enables us to estimate simultaneously other parameters more than just the gravity values of the network's stations.
- * The basic observables of the model are just the original dial readings of the gravimeters after converting them to miligal unites and being corrected to tide effects. This criterion is chosen to avoid working with the gravity differences as the model's observables because of two reasons:
 - (1) Several observation schemes have been used in the field work of the ENGSN97 (i-e., the step method , the profile method, .. etc.), and therefore, it is difficult to design a model that works with all these field procedures, at the same time.
 - (2) It is a matter of fact that the gravity differences measurements have high correlations between them while the original dial readings do not posses this property, as indicated before.

- * The model is general enough to accept introducing some systematic errors in the estimation process, to be treated as nuisance unknown parameters. For example, the drift rates and the calibration functions of the different gravimeters could be estimated in this model and their effects on the gravity values are taken into considerations.
- * The developed model is capable of dealing with absolute gravity measurements as well as the relative gravity measurements.
- * The model is compatible with some methods of detecting outliers so that this step being applied as a built-in routine to scan the data and flag any erroneous observations in order to increase the reliability of the estimated parameters.

Consequently, several gravity processing models have been developed in the form of observation equations, for a gravimeter reading, as a function of the involved unknown parameters, for each case of observation that can be encountered in practice, when establishing or densifying a first-order gravity network. Those developed processing models have been utilized and several efficient computer programs have been developed to process, adjust, and analyze gravity networks in several stages as:

- * Processing each single loop using a single gravimeter at a time,
- * Processing each single loop using several gravimeters combined together
- * Processing and adjustment the entire ENGSN97 network, and
- * Outlier detection within final adjustment of the ENGSN97.

The Gravity Network Processing and Adjustment (GNPA) developed software, is the main computational tool used in this research study. It processes and adjusts a gravity network that consists of several field loops observed by several gravimeters, with or without time breaks in the observation scheme, using the newly-developed model. The unknowns contain the gravity values of

observed stations and two unknowns (orientation and drift) for each virtual instrument. If a loop contains a break, its data set is further divided into two virtual data series and two unknowns have to be estimated to each data series.

The developed program GNPA, has been run to adjust the entire ENGSN97 gravity network. Of course, there are several items or criteria, associated with the adjustment of such entire network. These items depend upon the way of treating the gravimeter drift function, i.e., linear or non-linear; the way of treating the five absolute gravity stations included in the network, i.e., only one fixed or all absolute stations are taken as weighted parameters; the way of treating the gravimeter reading observations for the two different LCR used G and D models, i.e., introducing different weights for both of them; the way of treating the different involved observation loops in the network according to the length and the time span of observations for each loop, i.e., introducing different weights for different loops. All these items are investigated, one at a time, in order to end up with the best optimized solution for the ENGSN97 network, in which all significant influence factors have been taken into account . Finally, for the best solution, any existing outliers in the observations, are removed one at a time, until the best solution is completely filtered out, which gives the final best estimates for the point gravity values of the network, along with their accuracy estimates. Such process, of course, necessitates that the above mentioned developed software, to be run several times, leading to several solutions of the network, for final assessment of the obtained results. In this context, one can stipulate the required solution into the following obtained six ones:

- (1) Holding only one absolute station fixed for the assessment of the accuracy of the relative against the absolute gravity values, considering the gravimeter drift to be linear.

- (2) Treating all absolute stations as weighted parameters to investigate the consistency between the relative and absolute gravity measurements, considering the gravimeter drift to be linear.
- (3) Repeating the same second solution, but with treating the gravimeter drift to be non-linear in nature, to check the effect of higher order drift function validity.
- (4) Repeating the same second solution, however, with introducing different weights for the gravimeter readings, for both models G and D LCR type used gravimeters.
- (5) Fixing the second solution as a standard base for comparison, and introducing different weights for different observation loops of the network
- (6) Applying an outlier detection procedure for the assurance of the ENGSN97 quality of the final results.

The present research study investigates also, the influence factors affecting the quality and reliability of developing a final precise geoid solution for Egypt that, is based upon the combination of the available gravity and GPS-derived geoid undulations. The adopted techniques for geoid determinations, namely the gravimetric geoid computations using the Fast Fourier Technique (FFT), and the geometric satellite geoid determination, are utilized. Consequently, four gravimetric geoid solutions for Egypt have been produced, investigating the effect of the amount and quality of available gravity data, the global against a local Digital Elevation Models, the influence of the terrain effects to the observed gravimetric quantities. After integrating three different GPS data sets, as observed by the Survey Research Institute, the Egyptian Survey Authority, and the FINNMAP project, a geometric satellite geoid solution is obtained. Several fitting polynomials are investigated to obtain a final combined Gravity/GPS geoid solution for Egypt.

Results and conclusions

The main results and conclusions of the present research study may be given as:

(1) From studying all the developed least-squares adjustment solutions of the ENGSN97 gravity network, the following results and conclusions are obtained:

- * Holding only one of the known five absolute gravity stations as completely fixed gives differences between the known absolute gravity values, and the corresponding estimated values from the above adjustment, for the four absolute stations, almost in the same order of the precision of the relative gravity measurements, which indicates the existing consistency between both types of gravity measurements, namely the absolute and relative measurements.
- * Treating the absolute gravity stations as quasi-observables, with relatively high weights, improves the overall quality of the ENGSN97 gravity network. Such improvement, in the overall processing of the network, was found to be 11%.
 - * The second part of the non-linear drift function is statistically insignificant, and should be neglected, particularly since it deteriorates the overall quality of the entire gravity network by about 18% in our network here.
 - * Using 0.02 mGal standard deviation for the D-gravimeter relative gravity observations, gives a slight improvement in the precision, in the order of approximately 13%.
 - * Using standard deviation of 0.05 mGal for long gravity loops completed over more than one-day period, produces slight improvements in their precision, in the order of approximately 18%.

* For the outlier detection in the ENGSN97 gravity network, only 44 observations out of the original 1085 observations have been flagged and removed. These observations constitute only about 4 % of the total number of the measurements, which is another indication of the goodness of the ENGSN97 network.

Taking the above mentioned items into consideration and removing erroneous observations, produces improvements in the overall precision of the ENGSN97 network in the order of approximately 37%. Consequently, it can be concluded here that, the best appropriate adjustment of the ENGSN97 network should be done, using a linear drift function for the gravimeters, taking all absolute gravity measurements as weighted parameters, assigning different weights for both G and D models of LCR gravimeters, assigning different weights for the observed gravity loops according to their observing times, and rejecting outlier observations on the basis of appropriate statistical testing.

(2) Concerning the estimated gravity values at the network 150 stations, the obtained results indicate that the minimum adjusted gravity value was 978679.776 mGal while the maximum adjusted gravity value was 979504.981 mGal. Therefore, the gravity range over Egypt is 825.205 mGal with an average gravity value of 979126.005 mGal, with an average value of 979126.005 mGal. As an indication of the precision of the ENGSN97 network, the standard deviations of the adjusted gravity values range from 0.002 mGal to 0.048 mGal, with an average value of 0.021 mGal.. Therefore, it can be concluded that, the established ENGSN97 gravity network serves as the first-order gravity framework for Egypt, since it posses homogenous distribution (except in far west desert), precise gravity values, three-dimensional GPS coordinates, and orthometric heights.

(3) Regarding geoid determinations for Egypt, six geoid solutions have been developed. From these different geoid solutions, the following results are obtained:

- Having more accurate gravity data increases the precision of the geoid solution.
- Using the currently existing local DEM gives slightly better results than utilizing a global DEM. However, when a dense local DEM would be available, the improvements in geoid determination would increase significantly.
- For gravimetric geoid computations in Egypt, with a local DEM, it is not necessary to correct the used point gravity values for the terrain effects. This could be the case since most of the topography of the Egyptian territory, is more or less modest, except over small mountainous areas.
- The optimum strategy in developing local geoid in Egypt is the integration of gravimetric and GPS precise data.

Integrating gravimetric and GPS-based types of geoid undulation in a unified model, the model of second-order polynomial is the best model.

Consequently, as an overall conclusion, it can be stated here that, the well-distributed GPS-based undulations are expected to be the most accurate, and any other available gravimetric undulations or undulations determined from heterogeneous geodetic data, should be integrated to them, through the best reliable transformation models.

(4) A comparison between the developed final combined gravity/GPS geoid solution for Egypt, SRI-GEOID98, with some other previously-determined local geoids in Egypt, reveals that SRI-GEOID98 geoid solution gives least RMS, and hence, it may be considered as the best geoid model in hand that can be obtained from the available gravity and GPS data in Egypt. The data used in

developing this geoid model are the most-precise geodetic data available in the time being in Egypt especially the HARN-95 GPS net and the ENGSN97 gravity net. The final results include:

- * The SRI-GEOID98 geoid model has geoid undulations values ranging from 7.22 m to 22.55 m with the mean of 15.31 m and RMS equals 3.10.
- * For the meridian component, the minimum and maximum values have found to be $-23.55''$ and $24.73''$ with the average value of $-1.11''$ and RMS equals $4.35''$.
- * The prime vertical component ranges from $-36.16''$ to $26.26''$ with an average value of $1.02''$ and RMS equals $4.57''$.
- * The free-air gravity anomaly ranges from -122.42 mGal to 128.65 mGal with an average value of -3.21 mGal and RMS equals 28.55 mGal.
- * The Bouguer gravity anomaly ranges from -130.97 mGal to 81.76 mGal with an average value of -21.77 mGal and RMS equals 28.38 mGal.

Hence, as an overall conclusion, it can be stated here that, as long as additional precise gravity, GPS, or any other heterogeneous geodetic data, become available, a new updated geoid solution for Egypt must be re-computed and analyzed, for increasing its reliability and spectrum of applications.

Recommendations

Based on the previous conclusions, some recommendations may be suggested:

- (1) The established ENGSN97 gravity network should be used in the process of redefinition of the Egyptian geodetic datum and the associated reduction and computations of geodetic quantities needed for surveying and mapping activities.
- (2) It is highly recommended that the ENGSN97 gravity network being incorporated into any new global geopotential models in order to increase the accuracy of those models in representing at least the medium wavelength of the gravity field over Egypt.
- (3) Dense and precise local Digital Elevation Model (DEM) is needed for Egypt in order to be implemented in accurate terrain correction computation and high-precision local geoid determination.
- (4) Despite the fact that the ENGSN97 provides a precise gravity datum for Egypt, some gravity networks of less accuracy (second and third orders) are crucially needed to get dense representation of the gravity field and enable getting more accurate geoid model for the country.
- (5) Different models of integrating gravimetric and GPS-derived geoid undulations need more investigations for determining the optimum unifying strategy to take advantages of both types in developing high-precision geoid for Egypt. This could be done through introducing different weights for both

gravimetric and GPS-based undulations, when determining the optimum transformation models between them.

- (6) Whenever the opportunity exists, an additional number of absolute gravity measurements are recommended to be carried out, over the western and southern parts of the country, to complete a good distribution beside the already established five absolute gravity stations, which are expected to increase the reliability of the overall ENGSN97 network.
- (7) Cooperation between Egyptian and foreign organizations, interested in establishing first-order gravity networks and their applications, is highly recommended, for the updating and refinement of the observing and processing technologies, to cope with the rapidly increasing advances in this direction, and related disciplines.

List of references

Alnaggar, D., 1986, **Determination of the geoid in Egypt using heterogeneous geodetic data**, Ph.D. Dissertation, Cairo University, Cairo, Egypt.

Alnaggar, D., and Dawod, G., 1995a, **Increasing the reliability of GPS geodetic networks**, Proceedings of the First International Conference on Satellite Positioning Systems, December 12-13, Alexandria, Egypt.

Alnaggar, D., and Dawod, G., 1995b, **Potential of GPS observations in the ENGSN-97 network for geoid determination and associated comparisons**, Proceedings of Al-Azhar Fourth International Engineering Conference, December 16-19, Volume 3, pp. 341-353, Cairo, Egypt.

Alnaggar, D., and El-Sagheer, A., 1995, **Representation of gravity field in Egypt based on digital terrain model**, IUGG Meeting, Bolder, Colorado, USA, July 2-14.

Barada, W., 1968, **A Testing procedure for use in geodetic networks**, **Publications on Geodesy**, New Series, Netherlands Geodetic Commission, V. 2, N. 5, Delft, The Netherlands.

Bottoni, G. and Barzaghi, R., 1993, **Fast collocation**, Bulletin Geodesique, Vol. 67, No. 2, pp. 119-126.

Caspary, W., 1987, **Concepts of networks and deformation analysis**, Monograph No. 11, School of Surveying, University of New South Wales, Australia.

Chen, Y., Kavouras, M., Chrzanowski, A., 1987, **A strategy for detection of outlying observations in measurements of high precision**, The Canadian Surveyor, V. 41, N. 4, pp. 529-540.

Cole, J., 1944, **Geodesy in Egypt**, Government Press, Cairo, Egypt.

Dawod, G., 1991, **Some considerations in the adjustment of GPS-derived base lines in the network mode**, MSC thesis, Department of Geodetic Science and Surveying, The Ohio State University, Ohio, USA.

Dawod, G. and Alnaggar, D., 1997, **Performance of relative gravimeters and processing software over the new absolute gravity stations in Egypt**, Proceedings of Al-Azhar Fifth International Engineering Conference, December 19-22, Volume 5, pp. 113-125, Cairo, Egypt.

Denker, H., Behrend, D., and Torge, W., 1996, **The European gravimetric quasigeoid EGG96**, Proceedings of the IAG International Symposium No. 117, Tokyo, Japan, Sept. 30 - Oct. 5, 1996, pp. 532-539.

El Sagheer, A., 1995, **Development of a digital terrain model for Egypt and its application for a gravimetric geoid determination**, Ph.D. Thesis, Shoubra Faculty of Engineering, Zagazig University, Egypt.

El Tokhy, M., 1993, **Towards the redefinition of the Egyptian geodetic control networks: Geoid and best fitting reference ellipsoid by combination of heterogeneous data**, Ph.D. Thesis, Faculty of Engineering, Ain Shams University, Egypt.

Finnmap, 1989, **The Sinai and Eastern desert 1:50 000 topographic map project: Report on GPS surveys**, The Egyptian Survey Authority, Giza, Egypt.

Groten, E., and Tealeb, A., 1995, **The first part of repeated relative gravimetry in the active zone of Aswan lake, Egypt**, Bulletin of National Research Institute of Astronomy and Geophysics, Volume XI, pp. 255-264.

Heiskanen, W., and Moritz, H., 1976, **Physical geodesy**, Freeman And Company, San Francisco.

Kamel, H., and Nakhla, A., 1985, **Gravity map of Egypt**, The Egyptian Academy of Scientific Research and Technology, Cairo, Egypt.

Kühtreiber, N. and Rautz, K., 1996, **Gravimetric geoid of Austria**, Proceedings of the 7th International Meeting on Alpine Gravimetry, Vienna, Austria, pp. 103-112.

LaCoste and Romberge, 1989a, **GRAVAC, GMODEL, TERRAIN: MS-DOS programs for the reduction and interpolation of gravity survey data**, LaCoste and Romberge Gravity Meters, Inc., Texas, USA.

LaCoste and Romberge, 1989b, **Instruction manual for model G & D gravity meter**, LaCoste and Romberge Gravity Meters, Inc., Texas, USA.

Milbert, D. (U.S. National Geodetic Survey), 1997, Personal communications.

Milbert, D. and Smith, D., 1996, **Converting GPS heights into NAVD88 elevation with the GEOID96 geoid height model**, Proceedings of the GIS/LIS'96 annual conference, Denver, Colorado, USA, Nov. 19-21, pp. 681-692.

Mikhail, E, 1976, **Observations and least-squares**, University Press of America Inc., USA.

Morelli, C. et al., 1974, **The International Gravity Standardization Net 1971 (IGSN-71)**, IUGG - IAG, Publication Special No. 4, Paris, France.

Moritz, H., 1978, **Least-squares collocation**, Review of geophysics and space physics, Vol. 16, No. 3, pp. 421-430.

Nassar, M., Hanafy, M., and El-Tokhey, M., 1993, **The 1993 Ain Shams university (ASU93) geoid solutions for Egypt**, Proceedings of Al-Azhar Third International Engineering Conference, Cairo, Egypt, Sept. 18-21, Volume 4, pp. 395-407.

Nassar, M. and Alnaggar, D., 1988, **Prediction of free-air gravity anomaly map of Egypt using least-squares collocation**, Civil Engineering Scientific Bulletin, Faculty of Engineering, Al-Azhar University, Cairo.

Nassar, M., 1986, **Comparative study of different mathematical models for geoid determination – with special emphasis on the Egyptian situation**, The Scientific Bulletin of the Faculty of Engineering, Ain Shams University, No. 19, Cairo.

Nassar, M., 1984, **Geodetic position computations in two and three dimension**, Lecture Notes No. 8, Department of Public Works, Faculty of Engineering, Ain Shams University, Cairo, Egypt.

Nassar, M. M., 1981, **Matrix treatment of adjustment computations in surveying**, Lecture Notes No. 4, Department of Public Works, Faculty of Engineering, Ain Shams University, Cairo, Egypt.

Nassar, M. M., 1977, **Gravity field and leveled heights in Canada**, Department of Surveying Engineering, University of New Brunswick, U.N.B. Report No. 41, N.B., Canada.

Nassar, M. M., 1976, **The Earth gravity field**, Lecture notes, In the course of Physical Geodesy laboratory assignments, given at the Department of Surveying Engineering, University of New Brunswick, N.B., Canada.

Nassar, M. M., 1969, **Applications of interferometry for precise short distance measurements**, Seminar paper given at the Department of Surveying Engineering, University of New Brunswick, N.B., Canada.

Niebauer, T., Sasagawa, G., Faller, J., Hilt, R., Klopping, F., 1995, **A new generation of absolute gravimeters**, Metrologia, No. 32, pp. 159-180.

Pope, A, 1976, **The statistics of residuals and the detection of outliers**, NOAA Technical Report NOS 65 NGS 1, U.S. Department of Commerce, Washington, D.C., USA.

Rapp, R., Wang, Y., Pavlis, N., 1991, **The Ohio State 1991 geopotential and sea surface topography harmonics coefficient models**, Report No. 410, Department of Geodetic Science and Surveying, The Ohio State University, Columbus, Ohio, USA.

Saad, A., 1993, **Towards the redefinition of the Egyptian vertical control network**, Ph.D. Dissertation, Shoubra Faculty of Engineering, Zagazig University, Egypt.

Schwarz, K., Sideris, M., and Forsberg, R., 1990, **The use of FFT techniques in physical geodesy**, Geophysical Journal International, Vol. 100, pp. 485-514.

Scintrex Limited, 1990, **Gravity standardization network for the Hashemite kingdom of Jordan**, Final Report.

Shaker, A., 1982, **Three dimensional adjustment and simulation of the Egyptian geodetic network**, Ph.D. Thesis, Technique university in Graz, Austria.

Shaker, A., Saad, A., and El Sagheer, A., 1997a, **Enhancement of the Egyptian gravimetric geoid 1995 using GPS observations**, Proceedings of the International Symposium on GIS/GPS, Istanbul, Turkey, Sept. 15-19.

Shaker, A., El Sagheer, A., and., Saad, A., 1997b, **Which geoid fits Egypt better?**, Proceedings of the International Symposium on GIS/GPS, Istanbul, Turkey, Sept. 15-19.

Sideris, G., 1994, **Geoid determination by FFT techniques**, Lecture Notes, The International school for the determination and use of the geoid, Milan, Oct. 10-15.

Smith, D. and Milbert, D., 1996a, **Evaluation of preliminary models of the geopotential in the United States**, A special report to the Special Working Group of the International Geoid Service.

Smith, D. and Milbert, D., 1996b, **Evaluation of the EGM96 model of the geopotential in the United States**, A final report of the Special Working Group of the International Geoid Service.

Sünkel, H. (**Technical University Graz, Austria**), 1998, Personal Communications.

Survey Research Institute (**SRI**), 1995, **The Egyptian National Gravity Standardization Net (ENGSN-97)**, Progressive Technical Report No. 1, Cairo, Egypt.

Stizza, D., (**U.S. Defense Mapping Agency**), 1997, Personal communications.

Torge, W., 1989, **Gravimetry**, Walter de Gruyter, New York.

Torge, W., 1990, **Geodesy**, Walter de Gruyter, New York.

Torge, W., 1992, **Gravimetry and tectonics**, in Geodesy and Geophysics, Lecture Notes, Nordiska Kommissionen för Geodesi, Korpilampi, Finland.

Torge, W., 1994, **Development, state of the art, and problems at large scale geoid determinations**, International Geoid Service Bulletin No. 3.

Trimble, 1996, **Model 4000SSI GPS surveyor operation manual**, Trimble Navigation, Inc., California, USA.

Trimble, 1997, **GPSURVEY: GPS survey software's user manual**, Trimble Navigation, Inc., California, USA.

Tsuboi, C., 1979, **Gravity**, George Allen & Unwin, London.

Uotila, U., 1986, **Notes on adjustment computations, Part I**, Lecture Notes, Department of Geodetic Science and Surveying, The Ohio State University, Ohio, USA.

Vanicek, P., 1975, **Physical geodesy II**, Lectures Notes, Department of Surveying Engineering, University of New Brunswick, N.B., Canada.

Veronneau, M., 1996, **The GSD95 geoid model for Canada**, Proceedings of the IAG International Symposium No. 117, Tokyo, Japan, Sept. 30 - Oct. 5, 1996, pp. 573-580.

الشبكة القومية المصرية للجاذبية الأرضية

رسالة مقدمة
للحصول على درجة دكتوراه الفلسفة في الهندسة المساحية
كلية الهندسة بشبرا - جامعة الزقازيق

من

مهندس / **جمعة محمد داود**
باحث مساعد
معهد بحوث المساحة
المركز القومي لبحوث المياه
وزارة الأشغال العامة والموارد المائية

تحت إشراف

د. دلال صبحي النجار
مدير معهد بحوث المساحة
المركز القومي لبحوث المياه
وزارة الأشغال العامة والموارد المائية

د. د. أحمد عبد الستار شاكر
أستاذ المساحة والجيوديسيا
وكيل كلية الهندسة بشبرا
جامعة الزقازيق

د. عبد الله أحمد سعد
مدرس المساحة والجيوديسيا
كلية الهندسة بشبرا
جامعة الزقازيق

تعتبر قيم الجاذبية الأرضية من البيانات التي لها العديد من الاستخدامات في العلوم المرتبطة بدراسة الأرض مثل علوم المساحة و الجيوديسيا وكذلك في علوم الفيزيكا الأرضية حيث تعاطمت الحاجة في الآونة الأخيرة إلى دراسة واكتشاف الموارد الطبيعية مثل المياه الجوفية والبتترول • وبالتالي فإن شبكات الجاذبية الأرضية أصبحت مطلب حيوي على الصعيدين العالمي والوطني وخاصة مع نهاية القرن العشرين • ولخدمة أغراض التنمية الشاملة لجمهورية مصر العربية ، فقد تم إنشاء الشبكة القومية المصرية للجاذبية الأرضية ENGSN97 باستخدام أحدث وأدق أجهزة قياس الجاذبية الأرضية والتي تتكون من خمسة محطات جاذبية مطلقة و ١٤٥ محطة جاذبية نسبية •

أهداف البحث :

- ١- دراسة وتحليل شبكات الجاذبية الأرضية على المستويين القومي والعالمي •
- ٢- دراسة وتقويم أداء أجهزة قياس الجاذبية الأرضية النسبية وخاصة تلك الأجهزة التي تم استخدامها في إنشاء الشبكة القومية المصرية للجاذبية الأرضية •
- ٣- تطوير نماذج رياضية لحساب وضبط أرصاد الجاذبية الأرضية مع الأخذ في الاعتبار جميع طرق الرصد المستخدمة في إنشاء الشبكة القومية المصرية للجاذبية الأرضية •
- ٤- تطوير برامج حاسب آلي لاستخدام النماذج الرياضية التي تم تطويرها بأسلوب متقن •
- ٥- تطبيق الاختبارات الإحصائية على أرصاد الشبكة القومية المصرية للجاذبية الأرضية لتتقنتها وزيادة جودتها حتى يمكن الحصول على أدق قيم الجاذبية الأرضية لنقاط الشبكة القومية المصرية للجاذبية الأرضية •
- ٦- تطوير نموذج حديث لسطح الأرض (الجيويد) لجمهورية مصر العربية بناء على النتائج الدقيقة لقيم الشبكة القومية المصرية للجاذبية الأرضية مع دمجها بأرصاد الأقمار الصناعية • GPS

مكونات البحث :

يتكون البحث من سبعة أبواب :

- ١- مقدمة وعرض لجميع قياسات الجاذبية الأرضية التي تمت في مصر منذ عام ١٩٠٨ مع دراسة وتحليل النماذج الرياضية المستخدمة في بعض شبكات الجاذبية العالمية والمحلية مثل الشبكة المصرية للجاذبية الأرضية التي تم رصدها عام ١٩٧٧ (NGSBN-77) والشبكة العالمية للجاذبية الأرضية (IGSN-71) وكذلك الشبكة الأردنية للجاذبية الأرضية التي تم إنشائها في عام ١٩٩٠ •
- ٢- يشتمل هذا الباب على موجز لأجهزة قياس الجاذبية الأرضية سواء المطلقة أو النسبية بالإضافة إلى الطرق المختلفة المستخدمة في الرصد الحقلية والمقارنة بينها • وكذلك يعرض هذا الباب الأنواع المختلفة لشذوذ الجاذبية بالإضافة إلى استخدامات قيم الجاذبية الأرضية في تصحيحات القياسات المساحية •
- ٣- تقييم الشبكة القومية المصرية للجاذبية الأرضية (ENGSN97) بجميع مراحلها مثل التصميم ، الأجهزة المستخدمة وخصائصها ، طرق الرصد ، برامج الحاسب المتاحة •

٤- تطوير نماذج رياضية جديدة لمعالجة أرصاد الجاذبية الأرضية • ويستعرض هذا الباب الخطوات الرياضية التفصيلية التي تم تطويرها لاستنباط نماذج رياضية جديدة تأخذ في الاعتبار مميزات وعيوب النماذج السابقة وكذلك تطوير بعض برامج الحاسب الآلي لاستخدام النماذج الرياضية التي تم الحصول عليها •

٥- يقدم هذا الباب عرض للنتائج التي تم الحصول عليها لأدق وأحدث قيم الجاذبية الأرضية على المستوى القومي لجمهورية مصر العربية وذلك باستخدام البرامج التي تم تطويرها •

٦- عرض لنتائج استخدام القيم النهائية للجاذبية الأرضية على الصعيد القومي لتطوير العديد من نماذج سطح الأرض (الجيويد) والتي يمكن تقسيمها إلى ثلاثة مجموعات تشمل :

(أ) نماذج للجيود باستخدام بيانات الجاذبية الأرضية فقط وتضم هذه المجموعة أربعة حلول كالاتي :

نموذج الجيويد رقم ١ باستخدام بيانات الشبكة القومية للجاذبية الأرضية مع نموذج عالمي للارتفاعات •

نموذج الجيويد رقم ٢ باستخدام كافة بيانات الجاذبية الأرضية المتاحة في مصر مع استخدام نموذج عالمي للارتفاعات •

نموذج الجيويد رقم ٣ باستخدام كافة بيانات الجاذبية الأرضية المتاحة في مصر مع استخدام نموذج محلي للارتفاعات •

نموذج الجيويد رقم ٤ باستخدام كافة بيانات الجاذبية الأرضية المتاحة في مصر بعد إجراء تصحيحات تأثير الطبوغرافيا على قيم الجاذبية مع استخدام نموذج محلي للارتفاعات •

(ب) نموذج للجيود رقم ٥ باستخدام بيانات نظام الأقمار الصناعية GPS فقط وذلك بعد دمج ثلاثة مجموعات من أرصاد GPS تم رصدها في مصر بواسطة الهيئة المصرية العامة للمساحة - معهد بحوث المساحة - المشروع الفنلندي للخرائط •

(ج) نموذج للجيود رقم ٦ بدمج بيانات الجاذبية الأرضية مع بيانات نظام الأقمار الصناعية GPS وقد أطلق عليه اسم SRI-GEOID98 •

وكذلك يشمل هذا الباب عرض نتائج كافة نتائج النموذج النهائي SRI-GEOID98 و مقارنته ببعض قيم أرصاد GPS وأيضا بعض النماذج المحلية السابقة للجيود في مصر

٧- ملخص البحث و الخلاصة والتوصيات التي أمكن الحصول عليها •

نتائج البحث :

* تعتبر الشبكة القومية المصرية للجاذبية الأرضية ENGSN97 هي المرجع القومي لقيم الجاذبية الأرضية لما تتميز به من خصائص أهمها التوزيع المتجانس للمحطات والدقة العالية لقيم الجاذبية الأرضية وإحداثيات محطات الشبكة •

* أثبتت الدراسة أن استخدام قيم قراءات أجهزة قياس الجاذبية (وليس فرق قيم الجاذبية النسبية) هو الأسلوب الأمثل والأدق كمدخلات لبرامج الحساب التي يجب أن تؤدي هدفين هما معالجة البيانات وضبط الأرصاد في آن واحد •

* لحساب وضبط شبكات الجاذبية الأرضية الدقيقة ، فإن إتباع العوامل التالية يعطى أدق النتائج حيث يكون التحسن الإجمالي في حدود ٣٧ % :

- استخدام نموذج خطي لمعالجة الخطأ المنتظم (Drift) لأجهزة الرصد •

- استخدام قيمة انحراف معياري = ٠.٣ ر ملليجال لأرصاد حلقات الجاذبية الأرضية التي تم رصدها في فترة أقل من يوم .
- استخدام قيمة انحراف معياري = ٠.٥ ر ملليجال لأرصاد حلقات الجاذبية الأرضية التي تم رصدها في فترة أكبر من يوم حيث ينتج تحسن ١٨% .
- استخدام قيمة انحراف معياري = ٠.٢ ر ملليجال لأرصاد حلقات الجاذبية الأرضية التي تم رصدها بأجهزة الرصد الدقيقة (موديل D) حيث ينتج تحسن ١٣% .
- استخدام طريقة العناصر معلومة الوزن (Weighted Parameters) للتعبير عن دقة محطات الجاذبية المطلقة العالية الدقة أثناء إجراء عملية الضبط بطريقة مجموع أقل المربعات .
- استخدام الطرق الإحصائية لتنقية الأرصاد من أية أرصاد منخفضة الدقة .
- * بناء على نتائج الحلول المختلفة لحساب نموذج دقيق للجيويد في مصر ، فإن من أهم العناصر المؤثرة على دقة الجيويد ما يلي :
 - كلما زاد عدد ودقة بيانات الجاذبية الأرضية المستخدمة زادت دقة النموذج المحسوب .
 - استخدام نموذج محلي للارتفاعات وليس نموذج عالمي يعطى نتائج أدق بشرط كثافة ودقة النموذج المحلي .
 - أدق طرق حساب الجيويد هي المبنية على دمج كافة البيانات الجيوديسية (الجاذبية الأرضية- أرصاد الأقمار الصناعية GPS - الميزانيات الدقيقة ٠.٠٠ الخ) .
 - * نموذج الجيويد رقم ٦ الذي تم تطويره بدمج بيانات الجاذبية الأرضية مع بيانات نظام الأقمار الصناعية GPS وأطلق عليه اسم SRI-GEOID98 نتائجه كالتالي:
 - تراوحت قيم شذوذ البوجير للجاذبية الأرضية في جمهورية مصر العربية بين -١٣٠ر٩٧ و ٨١ر٧٦ مللي جال بمتوسط -٢١ر٧٧ مللي جال بينما تراوحت قيم شذوذ الجاذبية الأرضية (Free-Air) في جمهورية مصر العربية بين -١٢٢ر٤٢ و ١٢٨ر٦٥ مللي جال بمتوسط -٣ر٢١ مللي جال .
 - تراوحت قيم الشذوذ لسطح الجيويد النهائي الذي تم تطويره لجمهورية مصر العربية بين ٧ر٢٢ متر و ٢٢ر٥٥ متر بمتوسط ١٥ر٣١ متر كما تراوحت قيم انحراف المستوى الرأسي بين -٢٣ر٥٥" و ٢٤ر٧٣" في اتجاه شمال-جنوب بمتوسط -١ر١١" و بين -٣٦ر١٦" و ٢٦ر٢٦" في اتجاه شرق-غرب بمتوسط -١ر٠٢" .
 - * بمقارنة قيم الشذوذ لسطح الجيويد الذي تم تطويره بالقيم المناظرة المستنتجة من أرصاد GPS لبعض المحطات تراوحت الفروق بين -١ر٦٩ متر و -٤ر٨ متر بمتوسط -٤ر١ متر .
 - * بمقارنة نتائج سطح الجيويد الذي تم تطويره مع نتائج نماذج سابقة للجيويد في مصر تبين أن نموذج الجيويد المطور يعطى أقل انحراف معياري مما يدل على أن هذا النموذج هو الأدق في الوقت الراهن لتمثيل سطح الأرض لجمهورية مصر العربية .

توصيات البحث :

- (١) يجب الأخذ في الاعتبار استخدام الشبكة القومية المصرية للجاذبية الأرضية في أية محاولة لإعادة تحديد وتحديث المرجع الجيوديسي لجمهورية مصر العربية وكذلك في جميع الحسابات المتعلقة بتصحيحات القياسات المساحية و الجيوديسية .

- (٢) يجب إدخال القيم النهائية للشبكة القومية المصرية للجاذبية الأرضية وكذلك الشبكات الحديثة الدقيقة لأرصاد GPS في أية نماذج عالمية لمجال الجاذبية الأرضية يتم تطويرها مستقبلا حتى يمكن تحسين أداء ودقة هذه النماذج العالمية في مصر .
- (٣) يجب تطوير نماذج رقمية للارتفاعات (DEM) أكثر دقة من النموذج المتاح حاليا لجمهورية مصر العربية لما لهذه النماذج من تأثير على دقة حسابات مجال الجاذبية الأرضية وحسابات الجيويد .
- (٤) ضرورة تكثيف الشبكة القومية المصرية للجاذبية الأرضية بإنشاء شبكات داخلية على مسافات أقل حتى يمكن الحصول على تمثيل دقيق لمجال الجاذبية الأرضية في مصر مما يسمح بتطوير نماذج لشكل الأرض (الجيويد) ذات دقة أعلى لما لها من تطبيقات حيوية في علوم المساحة والخرائط .
- (٥) يجب إجراء دراسة مستفيضة لأفضل نماذج دمج بيانات الجاذبية الأرضية مع بيانات GPS في الحصول على نموذج دقيق للجيويد في مصر وخاصة كيفية إعطاء أوزان مختلفة لكل نوع من هذه الأرصاد .
- (٦) عندما تتوفر الفرصة ، يجب إنشاء عدد إضافي من محطات الجاذبية الأرضية المطلقة في مصر بالإضافة إلى المحطات الخمسة اللائي تم إنشاؤها في الشبكة القومية للجاذبية الأرضية وذلك لاستكمال التوزيع الجيد الموجود حاليا بغرض زيادة دقة وجودة الشبكة .
- (٧) ضرورة استمرار وجود تعاون علمي بين الجهات التطبيقية والبحثية في مصر والجهات العالمية المتخصصة في مجال شبكات الجاذبية الأرضية لمواكبة التطور السريع في تقنيات أرصاد وحسابات شبكات الجاذبية الأرضية.