

THE HISTORY OF THE

REIGN OF

CHARLES

THE

SECOND

BY JOHN HANCOCK

NATURAL LIGHT AND LIBRARIES

WAGIH FAWZI YOUSSEF

A DISSERTATION

IN

ARCHITECTURE

Presented to the Graduate Faculties of the University of Pennsylvania in Partial Fulfillment of the Requirements for the Degree of Doctor of Philosophy.

1979

Supervisor of Dissertation

Graduate Group Chairman

ABSTRACT

NATURAL LIGHT AND LIBRARIES

WAGIH FAWZI YOUSSEF, Ph.D.

UNIVERSITY OF PENNSYLVANIA 1979

Supervisor: Professor G. Holmes Perkins
Chairman of Graduate Group in Architecture and
University Professor of Architecture and Urbanism

To investigate the problem of light penetration and distribution in moderate sized public library reading rooms, five tests, theoretical and practical, were conducted.

The first test, using the sky projection concept, computed the percentage of the sky component received in the interior for the various seasons and times of day in the North temperate zone. This was an attempt to satisfy the need for a useful tool capable of giving a quick and reasonably accurate result while the design is still in its early stages. At this stage in the design process, the intricate technicality of the illuminating engineers' tables and formulas have proven to be of little use. This study attempts to solve this problem by simplifying the methodology.

Utilizing the data of the C. I. E. simplified table for standard overcast sky, the second test measured the relative influence of the window proportion, position, and area upon the light received at the work plane.

In the third test, a model of a room was constructed to detect the surfaces influencing the amount of the internally reflected com-

ponent from windows located at one side wall. Under these conditions, the contribution of the ceiling and the rear wall were the decisive factors in the internally reflected component. This knowledge provided the basis for a graphical method for determining, for lighting purposes, the optimum shape of ceiling and back wall in all types of rooms. This method proved to give more accurate, as well as more useful, data for the designer than the theory of integrated sphere or the split-flux concept.

One of the reasons for eye strain and visual distraction is to read in an environment of unbalanced brightness grading beyond the adaptive tolerance of the eye. For this reason, a fourth test was undertaken to find a formula to be used in testing the efficiency of windows in providing balanced brightness in relation to the room size and the depth of the work plane. Data for this formula were obtained from recording the brightness distribution of both the natural landscape and the sky luminance distribution.

The fifth test dealt with the influence of the window reveal shape upon the quantity and quality of light in the interior. The objective was to find a means of improving the window performance in cases where the freedom of enlarging the window is restricted. Windows with three different reveal shapes were chosen: reveals beveled to the exterior, square reveals, and reveals beveled to the interior.

Based on the five above tests, the following conclusions are:

- 1) that tall windows are more efficient in terms of light penetration and quality than either the square window or the horizontal window of the same glazing area,

- 2) that the ceiling and the back wall combined have the decisive impact upon the amount of the internally reflected component,
- 3) that it was possible to obtain a formula for brightness grading by observation and measurement of the distribution of light in the natural landscape. For the three zones the relationship is 1:0.3:0.10. This confirms a previous datum presented by Hopkinson for brightness grading, and
- 4) that the window with reveals beveled to the exterior introduces a great deal more light than when the reveals are square or beveled toward the interior.

ACKNOWLEDGEMENTS

I am deeply indebted to Professor A. Helmut Beckius, Chairman of Students Group in Architecture and University Professor of Architecture and Urbanism, who supervised all the development of this research and who gave me a generous amount of his knowledge and insight through his constructive criticism and comprehensive remarks.

I also extend my gratitude to Professor Peter Soderberg, Professor and Chairman of the Department of Architecture, for his scientific and moral support which I received as with the care of this study and from which I have benefited.

COPYRIGHT
Wagih Fawzi Youssef
1979

Also, my gratitude is expressed toward Professor David Van Vleet for his excellent advice and guidance.

My thanks to my family whose efforts cannot be forgotten, and to Iqbal Jemalovic who revised the manuscript, and to Mary Jarvis Kincaid, who typed and edited the text.

Finally, I am very thankful to the Egyptian Government who sponsored me during my stay in the U. S. A., and to the University of Pennsylvania who made this opportunity possible.

ACKNOWLEDGEMENTS

I am deeply indebted to Professor G. Holmes Perkins, Chairman of Graduate Group in Architecture and University Professor of Architecture and Urbanism, who supervised all the development of this research and who gave me a generous amount of his knowledge and insight through his constructive criticism and comprehensive overview.

I also extend my gratitude to Professor Peter McCleary, Professor and Chairman of the Department of Architecture, for his scientific and moral support which inspired me with the core of this study and from which many aspects evolved.

Also, my gratitude is expressed toward Professor David Van Zanten for his esteemed advices and guidance.

Many thanks to my family whose efforts cannot be forgotten, and to Lois Semanision who revised the manuscript, and to Mary Jarvis Kinzler, who typed and edited the text.

Finally, I am very thankful to the Egyptian Government who sponsored me during my stay in the U. S. A., and to the University of Pennsylvania who made this opportunity possible.

Daylight factor, 25, 27
Distribution of daylight, 2, 15, 20
diffuse lighting, 28, 144
Direct lighting, 2, 15, 20
Glare, 21, 104, 106
Distribution of daylight, 2, 5, 15, 21, 27, 101, 145, 191, 207,
208, 209, 210, 211, 214

INDEX

- Accommodation, 229
Acuity, 11, 12, 13, 30, 31, 32, 114
Albedo, 30
Altitude, solar, 11, 80, 85, 109, 130, 207
Angle of gain, 80, 136
Angle of separation, 33
Artificial lighting, 1, 3, 7, 9, 14, 15, 39, 40, 202, 223
Azimuth, solar, 11, 80, 85, 98, 100, 130
- Bay window, 246
Biological influences, 234
Brightness, 5, 8, 28, 32, 34, 37, 38, 40, 41, 47, 48, 49, 50, 71, 144, 210, 217, 218
Brightness grading, 28, 36, 42, 48, 49, 50, 104, 144, 147
Brise Soleil, 252
- C. I. E. Standard overcast sky, 85, 144
Cloud cover, 10, 11
Coefficient of utilization, 50
Color blindness, 215
Color contrast, 19, 42, 227
Color discrimination, 43, 47, 214
Colors, effects of, 3, 6, 8, 18, 31, 38, 43, 45, 222, 224, 225, 226, 230
Colors, sensitivity to, 18, 217, 227
Contrast, 7, 8, 34, 38, 209, 217, 250
Contrast sensitivity, 13, 18, 218
- Daylight distribution, 31, 36, 87, 148, 199, 207, 208, 209, 224, 235, 236
Daylight Factor, 25, 27
Deprivation of daylight, 8, 15, 235
Diffuse lighting, 38, 144
Direct lighting, 9, 12, 200
Disability glare, 71, 104, 106
Distribution of daylight, 5, 6, 18, 31, 87, 107, 148, 199, 207, 208, 209, 224, 235, 236

Egg-crate System, 133

Externally Reflected Component, 25, 29, 83, 84, 95

Fluorescent lighting, 15, 40

Furniture, effect on lighting, 42, 106, 185

Glare, 6, 7, 11, 21, 33, 36, 37, 38, 41, 54, 140, 144

disability, 71, 104, 106

discomfort, 8, 24, 27, 34, 139, 140, 142, 144, 226

effect of room reflectances, 27, 33, 37, 38, 40, 228

effect of surroundings, 33, 147, 223

effect of window size and position, 36

reduction of, 38, 252

sensation, 34

Glare formula, Hopkinson, 35, 139

Glass transmittance, effect of, 21, 141, 153, 163

Ground-reflected light, 12, 25, 56, 69, 71, 83, 90, 103, 200

Illumination, 6, 8, 12, 13, 14, 15, 36, 40, 59, 72, 150, 153, 181, 228

heat gain, 136, 141, 249, 253

internal, 12, 26, 31, 32, 207, 208, 210

recommendation, 32, 148, 151

Illumination from non-uniform overcast sky, 91, 147

Integrating Sphere, theory of, 21

Internally Reflected Component, 27, 56, 57, 59, 69, 83, 84, 100, 104, 138, 142

effect of internal furniture, 42, 106, 185

effect of internal reflections, 8, 11, 42, 55, 57, 139, 200

Interreflected light, 8, 34, 38, 55

Inverse square law, 95, 197

Kleffner, theory of, 95, 197

Latitude, 11, 109, 119, 207
 Library reading rooms, 6, 8, 9, 13, 19, 23, 50, 72, 104,
 105, 151, 185
 Light, sensitivity to, 13, 16, 17, 18, 214
 Louvers, design of, 133, 247
 Luminance, 12, 25, 28, 48, 90, 147, 217
 effects of, 216, 220, 240
 of illuminated facade and ground, 11, 16
 Luminance distribution of sky, 11, 239
 Luminosity, 7, 8, 207, 217

 Modeling, 104
 Mood, 7, 24, 142
 Munsell Color System, 43, 44

 Obstruction function "C", 57
 Obstructions, effects of, 41
 skylight penetration, 21
 Obstructions, external, 71, 83, 100, 106
 Orientation for sunlight, 132
 Overcast sky, C. I. E. Standard, 85
 Overcast sky luminance distribution, 7, 12, 25, 106, 107, 132,
 186, 200, 201
 C. I. E., 85, 91
 Philadelphia local, 91

 Perspective projection, 87, 105
 Phillips, Shadow angle protractor, 130
 Photometer, color and cosine corrected, 39, 59, 90, 200, 202
 Pleijel, daylight calculation, 87, 88
 Position, sky effect of, 34
 Projection of sky vault, 108
 Protractors, 52, 85, 86, 87, 88, 90, 95, 105, 106, 108, 150,
 185
 B. R. S. Daylight, 85, 153
 Sun Control, 132, 133
 Psychophysical influences, 14, 219, 221, 222, 231, 234, 235

Quality of daylight, 7, 9, 27, 38, 50, 51, 104, 186, 207
 Quantity of daylight, 8, 9, 27, 37, 38, 42, 50

Reflectance, 12, 69, 70, 81, 83, 84, 201, 208, 250
 of building materials, 6, 33, 37, 39, 42, 69, 238, 239, 242
 of obstructions, 41, 71, 81, 84, 106, 201
 Reflected sunlight, 12, 71
 Reveal, effect of, 37, 51, 72, 80, 83, 103, 199
 Reveal Reflection Component, R. R. C., 81, 83
 Room size, effect on daylight design, 8, 119, 183, 197, 210

Screen Card, Pleijel, 88
 Screen Figure, Pleijel, 88
 Shadow Angle Protractor, Phillips, 130
 Sky Component, 71, 83, 85, 86, 88, 95, 98, 100, 104, 105,
 137, 147, 153
 Sky Factor Calculation, 81, 83, 88
 Skylights and clerestories, 37, 85, 86, 100, 106, 107, 209,
 249, 252
 Sky luminance, 25, 34
 C. I. E. Standard, 97
 overcast sky, 197
 Philadelphia local, 91
 Solar altitude angle, 11, 80, 85, 109, 130, 207
 Solar azimuthal angle, 11, 80, 85, 98, 100, 130
 Solid angle measurement, 86, 103, 138
 Spectral energy distribution of daylight, 7, 22, 250
 effect of, 233
 Spectral sensitivity, 213
 Specularity, 39, 200
 Split-flux theory, 56, 69
 Stained glass, 240
 Standard of Comfort, 144
 Sun breakers, 107, 133, 137, 252
 Sun diagram, 119, 130
 Sunlight, direct, 10, 11, 20, 22, 25, 32, 37, 39, 71, 100, 119,
 137, 139, 143, 201, 253
 exclusion of, 107, 132, 136
 sunpath diagram, 11, 95, 107, 108, 130, 201
 sunshine, 108, 109, 119, 136
 Sun protractor, 107, 130, 132, 133, 136

15. Plei-jel Diagram for C. I. E. showing the percentage of overcast sky
 duration for each hour, from 8:00 AM to 4:00 PM throughout the
 months of the year for latitudes 31 degrees, 35 degrees, 40 de-
 grees, and 45 deg.

LIST OF FIGURES

16. Mean monthly total hours of sunshine for selected stations in
 the United States (after W. S. Department of Commerce) 101

1. Interior view of the room (model). 59

1. External view of the model showing the position and size of
 the window. 59

2. Graphical method of designing room shape for reading rooms
 with side windows and no externally reflected component. 73

3. Graphical method of determining the reading angles for rec-
 tangular rooms with side windows and external obstruction. 74

4. Graphical method of designing ceiling shape for optimum
 flashing in rectangular reading rooms with side windows and
 external obstruction. 75

5. Relative illuminances for reading rooms with side windows
 and different reveal shapes. 76

6. Relative illuminances for reading rooms with side windows
 and different reveal shapes. 77

7. Relative illuminances for reading rooms with side windows
 and different reveal shapes. 78

8. Relative illuminances for reading rooms with side windows
 and different reveal shapes. 79

9. The screen card used to prepare figures for use with the Plei-jel
 Diagrams (after Hopkinson). 89

10. Comparison between relative luminance distribution of C. I. E.
 overcast sky and Philadelphia's natural fully overcast sky. 92

11. Sky component due to an element of C. I. E. overcast sky at a
 reference point "P". 96

12. Protractor for C. I. E. overcast sky (unglazed window). 99

13. Plan and section of a room showing azimuthal sight lines and
 corresponding altitude angles. 101

14. Method of calculating the sky component from example in fig. 13
 by the aid of the proposed protractor for C. I. E. overcast sky.
 102

15.	Sun diagram for U. S. A. showing the percentage of overcast sky duration for each hour, from 9:00 AM to 4:00 PM throughout the months of the year for latitudes 32 degrees, 36 degrees, 40 degrees, and 44 degrees, North.	120
16.	Mean monthly total hours of sunshine for selected stations in the United States (after U. S. Department of Commerce).	121
17.	Mean monthly total hours of sunshine for January and February.	122
18.	Mean monthly total hours of sunshine for March and April.	123
19.	Mean monthly total hours of sunshine for May and June.	124
20.	Mean monthly total hours of sunshine for July and August.	125
21.	Mean monthly total hours of sunshine for September and October.	126
22.	Mean monthly total hours of sunshine for November and December.	127
23.	Mean monthly percentage of possible sunshine for selected stations in the U. S. A. (after U. S. Department of Commerce).	128
24.	Mean number of hours of sunshine in selected stations in U.S.	129
25.	Sun control protractor.	131
26.	Section of a room showing graphical determination of three different solutions of shades.	134
27.	Section and plan showing a graphical determination of an egg-crate shade.	135
28.	Sketch showing method of determining the average angle of gain for windows.	137
29.	Sketch showing the equivalent area of equal illumination with respect to a reference point.	152
30.	Comparison between the S.C.% obtained from different window shapes of the same surface area.	182
31.	Sky Component percentage due to a rectangular window placed vertically and then horizontally.	184
32.	Comparison between tall, horizontal, and square windows at reference points 5 and 15 feet from the window.	193
33.	Relation between the area of a square window and its S.C.% at distances 5, 10, 15 feet,	195

34.	Relative S.C.% increase with double increase of window areas (for square windows).	196
35.	Model of the room showing the window with reveals beveled to the exterior and positioned at one side of the wall.	203
36.	Model of the room showing the window with reveals beveled to the exterior and positioned in the center of the elevation (window can be enlarged in width by sliding the two sides).	203
37.	Model of the room having a window with square reveals and located at one side of the side wall (window reveals are extended 0.12 meters beyond the wall thickness).	204
38.	View of the room showing the window with square reveals positioned at the center of the elevation and the simulated lawn.	204
39.	Model showing the room with window having reveals beveled to the interior.	205
40.	Model of the room showing how the window with reveals beveled to the interior is centered and extended in width.	205
41.	View of the environment as seen by the window of the model on an overcast sky day.	206
42.	View of the environment facing the window of the model showing the pitched roofs of the opposite buildings at about 100 feet from the model.	206
43.	Performance of window 1.20 x 1.30 meters with reveals beveled to the interior.	256
44.	Performance of window 1.20 x 1.30 meters with square reveals.	257
45.	Performance of window 1.20 x 1.30 meters with reveals beveled to the exterior.	258
46.	Performance of window 1.80 x 1.30 meters with reveals beveled to the interior.	260
47.	Performance of window 1.80 x 1.30 meters with square reveals.	261
48.	Performance of window 1.80 x 1.30 meters with reveals beveled to the interior.	262
49.	Performance of window 2.40 x 1.30 meters with reveals beveled to the interior.	264
50.	Performance of window 2.40 x 1.30 meters with square reveals.	265

51.	Performance of window 2.40 x 1.30 meters with reveals beveled to the exterior.	266
52.	Performance of window 3.00 x 1.30 meters with reveals beveled to the interior.	268
53.	Performance of window 3.00 x 1.30 meters with square reveals.	269
54.	Performance of window 3.00 x 1.30 meters with reveals beveled to the exterior.	270
55.	Performance of window with reveals beveled to the interior (window size 3.60 x 1.30 meters).	272
56.	Performance of window 3.60 x 1.30 meters with square reveals.	273
57.	Performance of window 3.60 x 1.30 meters with reveals beveled to the exterior.	274
58.	Performance of window 4.00 x 1.30 meters with reveals beveled to the interior.	277
59.	Performance of window 4.00 x 1.30 meters with square reveals.	278
60.	Performance of window 4.00 x 1.30 meters with reveals beveled to the exterior.	279
61.	Performance of window 1.20 x 1.30 meters with reveals beveled to the interior.	282
62.	Performance of window 1.20 x 1.30 meters with square reveals.	283
63.	Performance of window 1.20 x 1.30 meters with reveals beveled to the exterior.	284
64.	Performance of window 1.80 x 1.30 meters with reveals beveled to the interior.	285
65.	Performance of window 1.80 x 1.30 meters with square reveals.	286
66.	Performance of window 1.80 x 1.30 meters with reveals beveled to the exterior.	287
67.	Performance of window 2.40 x 1.30 meters with reveals beveled to the interior.	288
68.	Performance of window 2.40 x 1.30 meters with square reveals.	289
69.	Performance of window 2.40 x 1.30 meters with reveals beveled to the exterior.	290

70.	Performance of window 3.00 x 1.30 meters with reveals beveled to the interior.	291
71.	Performance of window 3.00 x 1.30 meters with square reveals.	292
72.	Performance of window 3.00 x 1.30 meters with reveals beveled to the exterior.	293
73.	Performance of window 3.60 x 1.30 meters with reveals beveled to the interior.	294
74.	Performance of window 3.60 x 1.30 meters with square reveals.	295
75.	Performance of window 3.60 x 1.30 meters with square reveals.	296
76.	Performance of window 4.00 x 1.30 meters with reveals beveled to the interior.	297
77.	Performance of window 4.00 x 1.30 meters with square reveals.	298
78.	Performance of window 4.00 x 1.30 meters with reveals beveled to the exterior.	299
79.	Performance of window 1.20 x 1.30 meters with reveals beveled to the interior.	303
80.	Performance of window 1.20 x 1.30 meters with square reveals.	304
81.	Performance of window 1.20 x 1.30 meters with reveals beveled to the exterior.	305
82.	Performance of window 1.80 x 1.30 meters with reveals beveled to the interior.	308
83.	Performance of window 1.80 x 1.30 meters with square reveals.	309
84.	Performance of window 1.80 x 1.30 meters with reveals beveled to the exterior.	310
85.	Performance of window 2.40 x 1.30 meters with reveals beveled to the interior.	313
86.	Performance of window 2.40 x 1.30 meters with square reveals.	314
87.	Performance of window 2.40 x 1.30 meters with reveals beveled to the exterior.	315
88.	Performance of window 3.00 x 1.30 meters with reveals beveled to the interior.	318
89.	Performance of window 3.00 x 1.30 meters with square reveals.	319

90.	Performance of window 3.00 x 1.30 meters with reveals beveled to the exterior.	320
91.	Performance of window 3.60 x 1.30 meters with reveals beveled to the interior.	322
92.	Performance of window 3.60 x 1.30 meters with square reveals.	323
93.	Performance of window 3.60 x 1.30 meters with reveals beveled to the exterior.	324
94.	Performance of window 4.00 x 1.30 meters with reveals beveled to the interior.	326
95.	Performance of window 4.00 x 1.30 meters with square reveals.	327
96.	Performance of window 4.00 x 1.30 meters with reveals beveled to the exterior.	328
97.	Performance of window 1.20 x 1.30 meters with reveals beveled to the interior.	330
98.	Performance of window 1.20 x 1.30 meters with square reveals.	331
99.	Performance of window 1.20 x 1.30 meters with reveals beveled to the exterior.	332
100.	Performance of window 1.80 x 1.30 meters with reveals beveled to the interior.	333
101.	Performance of window 1.80 x 1.30 meters with square reveals.	334
102.	Performance of window 1.80 x 1.30 meters with reveals beveled to the exterior.	335
103.	Performance of window 2.40 x 1.30 meters with reveals beveled to the interior.	336
104.	Performance of window 2.40 x 1.30 meters with square reveals.	337
105.	Performance of window 2.40 x 1.30 meters with reveals beveled to the exterior.	338
106.	Performance of window 3.00 x 1.30 meters with reveals beveled to the interior.	339
107.	Performance of window 3.00 x 1.30 meters with square reveals.	340
108.	Performance of window 3.00 x 1.30 meters with reveals beveled to the exterior.	341

109.	Performance of window 3.60 x 1.30 meters with reveals beveled to the interior.	342
110.	Performance of window 3.60 x 1.30 meters with square reveals.	343
111.	Performance of window 3.60 x 1.30 meters with reveals beveled to the exterior.	344
112.	Performance of window 4.00 x 1.30 meters with reveals beveled to the interior.	345
113.	Performance of window 4.00 x 1.30 meters with square reveals.	346
114.	Performance of window 4.00 x 1.30 meters with reveals beveled to the exterior.	347
115.	Performance of window 1.20 x 1.30 meters with reveals beveled to the interior.	351
116.	Performance of window 1.20 x 1.30 meters with square reveals.	352
117.	Performance of window 1.20 x 1.30 meters with reveals beveled to the exterior.	353
118.	Performance of window 1.80 x 1.30 meters with reveals beveled to the interior.	354
120.	Performance of window 1.80 x 1.30 meters with square reveals.	355
121.	Performance of window 1.80 x 1.30 meters with reveals beveled to the exterior.	356
122.	Performance of window 2.40 x 1.30 meters with reveals beveled to the interior.	357
123.	Performance of window 2.40 x 1.30 meters with square reveals.	358
124.	Performance of window 2.40 x 1.30 meters with reveals beveled to the exterior.	359
125.	Performance of window 3.00 x 1.30 meters with reveals beveled to the interior.	360
126.	Performance of window 3.00 x 1.30 meters with square reveals.	361
127.	Performance of window 3.00 x 1.30 meters with reveals beveled to the exterior.	362
128.	Performance of window 3.60 x 1.30 meters with reveals beveled to the interior.	363

129.	Performance of window 3.60 x 1.30 meters with square reveals.	364
130.	Performance of window 3.60 x 1.30 meters with reveals beveled to the exterior.	365
131.	Performance of window 1.20 x 1.30 meters with reveals beveled to the interior.	366
132.	Performance of window 1.20 x 1.30 meters with square reveals.	367
133.	Performance of window 1.20 x 1.30 meters with reveals beveled to the exterior.	368
134.	Performance of window 1.80 x 1.30 meters with reveals beveled to the interior.	369
135.	Performance of window 1.80 x 1.30 meters with square reveals.	370
136.	Performance of window 1.80 x 1.30 meters with reveals beveled to the exterior.	371
137.	Performance of window 2.40 x 1.30 meters with reveals beveled to the interior.	372
138.	Performance of window 2.40 x 1.30 meters with square reveals.	373
139.	Performance of window 2.40 x 1.30 meters with reveals beveled to the exterior.	374
140.	Performance of window 3.00 x 1.30 meters with reveals beveled to the interior.	375
141.	Performance of window 3.00 x 1.30 meters with square reveals.	376
142.	Performance of window 3.00 x 1.30 meters with reveals beveled to the exterior.	377
143.	Performance of window 3.60 x 1.30 meters with reveals beveled to the interior.	378
144.	Performance of window 3.60 x 1.30 meters with square reveals.	379
145.	Performance of window 3.60 x 1.30 meters with reveals beveled to the exterior.	380
146.	Performance of window 1.20 x 1.30 meters with reveals beveled to the interior.	381
147.	Performance of window 1.20 x 1.30 meters with square reveals.	382

148.	Performance of window 1.20 x 1.30 meters with reveals beveled to the exterior.	383
149.	Performance of window 1.80 x 1.30 meters with reveals beveled to the interior.	384
150.	Performance of window 1.80 x 1.30 meters with square reveals.	385
151.	Performance of window 1.80 x 1.30 meters with reveals beveled to the exterior.	386
152.	Performance of window 2.40 x 1.30 meters with reveals beveled to the interior.	387
153.	Performance of window 2.40 x 1.30 meters with square reveals.	388
154.	Performance of window 2.40 x 1.30 meters with reveals beveled to the exterior.	389
155.	Performance of window 3.00 x 1.30 meters with reveals beveled to the interior.	390
156.	Performance of window 3.00 x 1.30 meters with square reveals.	391
157.	Performance of window 3.00 x 1.30 meters with reveals beveled to the exterior.	392
158.	Performance of window 3.60 x 1.30 meters with reveals beveled to the interior.	393
159.	Performance of window 3.60 x 1.30 meters with square reveals.	394
160.	Performance of window 3.60 x 1.30 meters with reveals beveled to the exterior.	395
161.	Performance of window 1.20 x 1.30 meters with reveals beveled to the interior.	396
162.	Performance of window 1.20 x 1.30 meters with square reveals.	397
163.	Performance of window 1.20 x 1.30 meters with reveals beveled to the exterior.	398
164.	Performance of window 1.80 x 1.30 meters with reveals beveled to the interior.	399
165.	Performance of window 1.80 x 1.30 meters with square reveals.	400
166.	Performance of window 1.80 x 1.30 meters with reveals beveled to the exterior.	401

167.	Performance of window 2.40 x 1.30 meters with reveals beveled to the interior.	402
168.	Performance of window 2.40 x 1.30 meters with square reveals.	403
169.	Performance of window 2.40 x 1.30 meters with reveals beveled to the exterior.	404
170.	Performance of window 3.00 x 1.30 meters with reveals beveled to the interior.	405
171.	Performance of window 3.00 x 1.30 meters with square reveals.	406
172.	Performance of window 3.00 x 1.30 meters with reveals beveled to the exterior.	407
173.	Performance of window 3.60 x 1.30 meters with reveals beveled to the interior.	408
174.	Performance of window 3.60 x 1.30 meters with square reveals.	409
175.	Performance of window 3.60 x 1.30 meters with reveals beveled to the exterior.	410
176.	Comparison between performances of windows with different reveal shapes for selected reference points.	420
177.	Comparison between performances of windows with different reveal shapes for reference points located axial to the windows.	421
178.	Comparison between performances of windows with different reveal shapes for reference points off-center of the windows.	422
179.	Comparison between performances of windows with different reveal shapes for selected reference points.	423
180.	Comparison between performances of windows with different reveal shapes for reference points axial to the windows.	424
181.	Comparison between performances of windows with different reveal shapes for reference points off-center of the windows.	425
182.	Comparison between performances of windows with different reveal shapes for selected reference points.	426
183.	Comparison between performances of windows with different reveal shapes for reference points located axial to the windows.	427
184.	Comparison between performances of windows with different reveal shapes for reference points axial to the windows.	428

185.	Comparison between performances of windows with different reveal shapes for selected reference points.	429
186.	Comparison between performances of windows with different reveal shapes for reference points axial to the windows.	430
187.	Comparison between performances of windows with different reveal shapes for reference points off-center of the windows.	431
188.	Comparison between performances of windows with different reveal shapes located at one side of the wall.	432
189.	Comparison between performances of windows with different reveal shapes located at one side of the wall for reference points along the center of the room.	433
190.	Comparison between performances of windows with different reveal shapes located at one side of the wall for reference points at the same side as the window.	434
191.	Comparison between performances of windows with different reveal shapes located at one side of the wall for selected reference points.	435
192.	Comparison between performances of windows with different reveal shapes located at one side of the wall for reference points along the center of the room.	436
193.	Comparison between performances of windows with different reveal shapes located at one side of the wall for reference points on the same side.	437
194.	Comparison between performances of windows with different reveals shapes located at one side of the wall for selected reference points.	438
195.	Comparison between performances of windows with different reveal shapes located at one side of the wall for reference points along the center of the room.	439
196.	Comparison between performances of windows with different reveal shapes located at one side of the wall for reference points on the same side.	440
197.	Comparison between performances of windows with different reveal shapes located at one side of the wall for selected reference points.	441
198.	Comparison between performances of windows with different reveal shapes located at one side of the wall for reference points along the center of the room.	442

199. Comparison between performances of windows with different reveal shapes located at one side of the wall for reference points on the same side. 443

LIST OF TABLES

1. Influence of the reflectivity of the room boundaries upon its illumination.	80
2. Influence of the reflectivity of the room boundaries upon its illumination.	82
3. Influence of the disposition of a black side wall of a room in different locations upon the illumination of the room.	88
4. Influence of the disposition of a black back wall of a room in different locations upon its illumination.	88
5. Influence of the disposition of a black front wall including the window on different locations upon the illumination of the room.	87
6. Influence of the disposition of the wall color upon the illumination of the room.	89
7. Relative luminance distribution of the natural overcast sky of Philadelphia, Pennsylvania, May 5, 1936, 12:30 - 12:30 local time.	93
8. Probability of overcast sky duration for latitude 37 degrees North.	110
9. Probability of overcast sky duration for latitude 38 degrees North.	111
10. Probability of overcast sky duration for latitude 40 degrees North.	112
11. Probability of overcast sky duration for latitude 44 degrees North.	113
12. Relationship between the brightness of sunny and shaded wall areas at the Campus of the University of Pennsylvania.	141
13. A. S. C. Simplified table for a C. I. N. fully overcast sky.	154
14. Comparison between the performances of rectangular windows having different properties.	155

15. Performance of square windows having areas equivalent to the rectangular windows listed previously in Table 14. 181

16. Influence of square windows' areas increase upon the distribution of light at various distances from the window centers. 187

LIST OF TABLES

17. Effect of the window size and proportion upon the distribution of light at various distances from the window centers. 193

1. Influence of the reflectivity of the room boundaries upon its illumination. 60

2. Influence of the reflectivity of the room boundaries upon its illumination. 62

3. Influence of the disposition of a black side of a room in different locations upon the illumination of the room. 65

4. Influence of the disposition of a black back wall of a room in different locations upon its illumination. 66

5. Influence of the disposition of a black front wall (excluding the window) on different locations upon the illumination of the room. 67

6. Influence of the division of the wall color upon the illumination of the room. 68

7. Relative Luminance distribution of the natural overcast sky of Philadelphia, Pennsylvania, May 6, 1978, 14:30 - 15:30 Local Time. 93

8. Probability of overcast sky duration for Latitude 32 degrees North. 110

9. Probability of overcast sky duration for Latitude 36 degrees North. 112

10. Probability of overcast sky duration for Latitude 40 degrees North. 115

11. Probability of overcast sky duration for Latitude 44 degrees North. 117

12. Relationship between the brightness of sunny and shaded soil areas at the Campus of the University of Pennsylvania. 145

13. B. R. S. Simplified table for a C. I. E. fully overcast sky. 154

14. Comparison between the performances of rectangular windows having different proportions. 155

15.	Performances of square windows having areas equivalent to the rectangular windows tested previously in Table 14.	161
16.	Influence of square windows' areas increase upon the distribution of light at reference points, 5, 10, and 15 feet from the window corner.	167
17.	Effect of the window size and proportion upon the distribution of light at reference points 5, 10, and 15 feet from the window corner.	170
18.	Losses in Sky Component due to variation in window proportion.	176
19.	Comparison between the light distribution from windows having equal areas but different proportions.	179
20.	Sky Component distribution at 5, 10, and 15 feet, due to variations in window proportions.	187
21.	Comparison between the proportions of Sky Component distribution for horizontal and square windows relative to the vertical window.	191
22.	Relative increase of Sky Component with double increase in the areas of square windows for reference points 5, 10, and 15 feet away from the window corner.	192
23.	Comparison between different windows' performances (exterior ground cover is concrete).	412
24.	Comparison between different windows' performances.	413
25.	Comparison between different windows' performances.	414
26.	Comparison between different windows' performances.	415
27.	Comparison between different windows' performances.	416
28.	Comparison between different windows' performances.	417
29.	Comparison between different windows' performances.	418
30.	Comparison between different windows' performances.	419

Albright, Donald: Studies on Contrasting Problems in Vision, Psychology 1938.

Alla, Nandaram: Some Quantitative Aspects of Allochthonous Color Contrast, Psychologica 1967.

Arnheim, Rudolf: Perception and Psychological Aspects of a Particular of Color and Contrast, The Ocular Effect in Man and Animal, Psychological Bulletin 1972.

Arnheim, Rudolf: Art and Visual Perception, A Psychology of the Creative Eye, The New Version, Berkeley and Los Angeles, University of California Press, 1974.

Arnheim, Rudolf: Visual Thinking, Berkeley and Los Angeles, University of California Press.

Atkey, J. and Dennis, C. A.: Can Reduced Intraocular Visibility Through Fog, Illuminating Engineering Society, April 1966.

Atkey, J. and Dennis, C. A.: Learned in Relationship Between Vision and Attention, **BIBLIOGRAPHY** Journal of Scientific Study, Berkeley 1968.

Blackwell, G. Richard: A General Quantitative Method for Evaluating the Visual Discrimination of Reflected Colors Utilizing Visual Field Response Data, Illuminating Engineering Society, April 1963.

Blackwell, G. Richard: Further Validation Studies of Visual Task Evaluation, Illuminating Engineering Society, September 1964.

Blackwell, G. Richard and Blackwell, G. Richardson: The Effect of Illuminance Quantity on the Performance of Different Visual Tasks, Illuminating Engineering Society, April 1964.

Blackwell, G. Richard and Blackwell, G. Richardson: Visual Response and Data for Normal Observers of Various Ages, Illuminating Engineering Society, Vol. 12, October 1971.

Cleer, Nancy: Afterimage, How you see for Days, Teaching and Training, New York, Charles C. Thomas Books, Springfield, Van Nostrand Reinhold Company, 1977.

Cooper, David Robert: Minimum Perceptual Distance and Installation, NBSA publication 1974.

Goodfellow, James: Subjective Perception of Natural Light and Artificial Light, Architectural Record, April 1940.

- Akishige, Yoshiharu: Studies on Constancy Problem in Japan, Psychologia 1958.
- Akita, Munehera: Some Quantitative Aspects of Simultaneous Color Contrast. Psychologia 1967.
- Appelle, Stuart: Perception and Discrimination as a Function of Stimulus Orientation, The Oblique Effect in Man and Animal, Psychological Bulletin 1972.
- Arnheim, Rudolf: Art and Visual Perception, A Psychology of the Creative Eye, The New Version, Berkley and Los Angeles, University of California Press, 1974.
- Arnheim, Rudolf: Visual Thinking, Berkley and Los Angeles, University of California Press.
- Ashley, A. and Douglas, C. A.: Can Infrared Improve Visibility Through Fog?, Illuminating Engineering Society, April 1966.
- Azuma, Hiroshi and Ericksen, C. W.: Learning in Brightness Discrimination as Affected by the Introduction of Electric Shock, Psychologia 1964.
- Blackwell, H. Richard: A General Quantitative Method for Evaluating the Visual Significance of Reflected Glare Utilizing Visual Performance Data, Illuminating Engineering Society, April 1963.
- Blackwell, H. Richard: Further Validation Studies of Visual Task Evaluation, Illuminating Engineering Society, September 1964.
- Blackwell, H. Richard and Blackwell, O. Mortenson: The Effect of Illumination Quantity upon the Performance of Different Visual Tasks, Illuminating Engineering Society, April 1968.
- Blackwell, H. Richard and Blackwell, O. Mortenson: Visual Performance Data for Normal Observers of Various Ages, Illuminating Engineering Society, Vol. 1 N1, October 1971.
- Blaser, Werner: After Mies, Mies van der Rohe, Teaching and Principles, New York Cincinnati Toronto London Melbourne, Van Nostrand Reinhold Company, 1977.
- Beckett, Harold Edward: Windows: Performance Design and Installation, RIBA Publication 1974.
- Blumenfeld, Hans: An Integration of Natural Light and Artificial Light, Architectural Record, April 1940.

- Boud, John: Lighting Design in Buildings, Guildford and London, Peter Peregrinus Ltd, publishers, Billing and Sons Limited, 1973.
- Bourne, Lyle B., and Ekstrand, Bruce R.: Psychology, Its Principles and Meanings, Hinsdale, Illinois, The Dryden Press, 1973.
- Bradly, R. D. and Logan, H. C.: A Uniform Method for Computing the Probability of Comfort Response in a Visual Field, Illuminating Engineering Society, March 1964.
- Bronstein, Marc H.: Color Vision and Color Naming, A Psycho-physiological Hypothesis of Cultural Differences, Psychological Bulletin Vol. 80 No.4, October 1973.
- Brownfield, A.: Sensory Deprivation, A Comprehensive Survey, Psychologia 1964.
- Brownfield, Charles A.: Sensory Deprivation, A Comprehensive Survey, Psychologia 1964.
- Building Research Institute: Building Illumination, The Effect of New Lighting Levels, Publication No. 744, National Academy of Sciences, National Research Council, Washington DC 1959.
- Building Research Institute: Solar Effects on Building Design, Publication No. 1007. BRI, Inc., 1963.
- Canter, David and Lee, Terence (ed.): Psychology and the Built Environment, Published in the U.S.A. by Halsted Press, a division of John Wiley and Sons, New York, Printed in England by Whitefriars Press Ltd, Tonbridge Kent, 1974.
- Charles, George Herbertson: Stained and Painted Glass, American Churches, Vol. I, The American Architect, New York 1915.
- Collins, Peter: Changing Ideals in Modern Architecture (1750-1950), London, Faber and Faber, 1971.
- Cook, John W. and Klotz, Heinrich: Conversations With Architects, New York, Praeger Publishers, 1973.
- Culjat, Boris: Climate and the Built Environment in the North, Avhandling for Technisk Doktorsexamen vid Institutionen for Arkitektur, KTH, Stockholm 1975.
- Danz, Ernest: Sun Protection, An International Architectural Survey, New York, Fredrick A. Praeger Publishers, 1967.
- DeLaney, W. B.: A Simplified Field Indicator of Veiling Reflections, Illuminating Engineering Society, March 1968.

- Department of the Environment, Welsh Office: Sunlight and Daylight, Planning Criteria and Design of Buildings, London, Her Majesty's Stationery Office 1971.
- Dondis, Donis A.: A Primer of Visual Literacy, Cambridge, Massachusetts, and London, England, The MIT Press, 1974.
- Eastman, A. A.: Color Contrast vs. Luminance Contrast, Illuminating Engineering Society, Vol. 63, 1968.
- Edwards, Austin S.: Effect of Color on Visual Depth Perception, The Journal of General Psychology, 1955.
- Ellsworth, Ralph E.: Academic Library Buildings, A Guide to Architectural Issues and Solutions, Boulder, Colorado, The Colorado Associated University Press, 1973.
- Ferree, J. B.: Primitive Architecture, (S. N.), New York, 1890.
- Fitch, James Marston: American Building, The Environmental Forces That Shape It, Shoken Books, publishers, 1975.
- Flynn, John E. and Mills, Samuel M.: Architectural Lighting Graphics New York, Reinhold Publishing Corporation, 1962.
- Frankl, Paul: Principles of Architectural History, The Four Phases of Architectural Style 1420 - 1900, Cambridge, Massachusetts and London, England, The MIT Press, Massachusetts Institute of Technology, 1973.
- Gadol, Joan: Leon Battista Alberti, Universal Man of the Early Renaissance, Chicago and Lond, The University of Chicago Press, 1973.
- Gauldi, Sinclair: Architecture, The Appreciation of Arts/I, London, New York, Toronto, Oxford University Press, 1969.
- Goldwater, Bran C.: Psychological Significance of Pupillary Movements, Psychological Bulletin, Vol. 77 No. 5, May 1972.
- Gregory, R. L.: Eye and Brain, The Psychology of Seeing, New York Toronto, World University Library, Second ed. 1973, McGraw-Hill Book Company, reprinted 1974.
- Griffith, J. W.: Analysis of Reflected Glare and Visual Effect From Windows, Illuminating Engineering Society, March 1964.
- Gropius, Walter: Scope of Total Architecture, Collier Book 1974.
- Guth, Sylvester K. and McNelis, John F.: Visual Performance, Subjective Difference, Illuminating Engineering Society, December 1969.

- Haber, Ralph Norman and Fried, Aharon H.: An Introduction to Psychology, Holt, Rinehart and Winston, Inc., 1975.
- Halse, Albert O.: The Use of Color in Interiors, Second edition
Mc-Graw Hill Book Company, 1978.
- Henderson, S. T. and Marsden, A. M. (general editors): Lamps and Lighting, A Manual of Lamps and Lighting Prepared by Members of Staff of Thorn Lighting Ltd., New York, Crane, Russak and Company, Inc., Second edition 1972.
- Henderson, S. T.: Daylight and its Spectrum, New York, American Elsevier Publishing Company, Inc., 1970.
- Hewitt, H. and Vause, A. S. (general editors): Lamps and Lighting, A Manual of Lamps and Electric Lighting prepared by Members of the Research and Engineering Staff of British Lighting Industries Ltd., and the technical Staff of the Associated companies: Atlas Lighting Limited, A. E. I. Lamp and Lighting Company, Ltd., and Ekco Ensign Electric Limited, London, Edward Arnold, publisher, Ltd., 1966.
- Hochberg, Julian E.: Perception, Englewood Cliffs, New Jersey, Prentice-Hall, Inc., 1964.
- Hopkinson, R. G.: Architectural Physics, Lighting, London, Her Majesty's Stationery Office, 1963.
- Hopkinson, R. G. and Petherbridge, P. and Longmore, J.: Daylighting, London, Melbourne, Toronto, Cape Town, Auckland, William Heinemann Ltd., 1966.
- Hopkinson, R. G. and Kay, J. D.: The Lighting of Buildings, London, Faber and Faber, 1972.
- Huntington, Ellsworth and Cushing, S. W.: Principles of Human Geography, New York, Third edition, Willey, 1920-1924.
- Illuminating Engineering Society (sponsor): American Standard Practice for Office Lighting, New York, Illuminating Engineering Society, RP-1, 1960.
- I. E. S.: Lighting of Libraries, Technical Report No. 8, London, Illuminating Engineering Society, 1966.
- I. E. S. Committee: Lighting Interior Living Spaces, Light and Color, Illuminating Engineering Society, August 1969.
- I. E. S.: I. E. S. Lighting Handbook, New York, First edition, 1947.

- Indow, Tarow and Kuno, Ulora and Yoshida, Toshiro: Studies on the Induction in Visual Process Taking Electrical Phosphene as an Index, Psychologia 1958.
- Kaufman, John E. (ed.): I. E. S. Lighting Handbook, Fourth Edition, New York, Illuminating Engineering Society, 1966.
- Kaufman, Lloyd: Sight and Mind, An Introduction to Perception, New York, London, Toronto, Oxford University Press, 1974.
- Kaula, Prithvi N.: Library Buildings, Planning and Design, New York Oceana Publications, Inc., 1971.
- Koenigsberg, O. H., Ingersoll, T. G., Mayhew, A., and Szokolay, S. V.: Manual of Tropical Housing and Building, Part One: Climatic Design, Longman Group Limited, 1974.
- Kohler, Walter Dr.: Lighting in Architecture, Light and Color as Stereoplastic Elements, New York, Reinhold Publishing Company, 1959.
- Kohler, Wolfgang: Unsolved Problems in the Field of Figural After-Effects, Psychological Record 1965.
- Lam, William M. C.: Perception and Lighting as Formgivers for Architecture, McGraw-Hill Book Company, 1977.
- Landis, Daniel and Harrison, Sylvia: Effect of Amount of Scanning From Memory on Phenomenal Size of Objects, The Psychological Record 1967.
- Larson, Leslie: Lighting and Its Design, New York, Whitney Library of Design, 1964.
- Logan, Henry L.: The Relationship of Light to Health, Illuminating Engineering Society, March 1967.
- Longmore, James: Lighting of Work Places, Ergonomics for Industry, No. 9, Ministry of Technology, Millbank Tower, Millbank, London, SW1, January 1966.
- Lowenthal, David (ed.): Environmental Perception and Behavior, The University of Chicago, Department of Geography Research Paper No. 109, 1967.
- Lynes, J. A.: Principles of Natural Lighting, London, Applied Science Publishers Ltd., 1968.
- Luckiesh, M.: Visual Illusions, Their Causes, Characteristics, and Applications, New York, Dover Publications, Inc., 1965.
- McConnel, James V.: Understanding Human Behavior, An Introduction to Psychology, Holt Reinhart and Winston, Inc., 1974.

- McGrath, Raymond and Frost, A. C.: Glass in Architecture and Decoration, London, The Architectural Press, 1961.
- Motokawa, Koiti and Akita, Munehira: Electrophysiological Studies of the Field of Retinal Induction, Psychologia 1957.
- Nakacawa, Dairin: Muller-Lyer Illusion and Retinal Induction, Psychologia 1958.
- Nakano, Akiko: Eye Movements in Relation to Mental Activity of Problem Solving, Psychologia 1971.
- National Bureau of Standards: Improved Building Design Through the Psychology of Perception, NBSIR 76-1046, Reproduced by National Technical Information Service, U. S. Department of Commerce, Springfield, VA.
- Neufert, Ernst: Architects' Data, Edited and revised by Rudolf Herz, Friiba, Dr, Ing, (Berlin), London, Crosby Lockwood and Son Ltd, 1970.
- Nuckolls, James L.: Interior Lighting for Environmental Designers, A Willey-Inter-Science publication, New York, London, Sydney, Toronto, John Wiley and Sons, 1976.
- Obonai, Toao: The Concept of Psycho-physiological Induction, A Review of Experimental Work, Psychologia 1957.
- Olgay, Victor: Design With Climate, Bioclimatic Approach to Architectural Regionalism, Princeton, New Jersey, Princeton University Press, Fourth printing, 1973.
- Oyama, Tadasu: Japanese Studies on the So-Called Geometrical-Optical Illusion, Psychologia 1960.
- Ott, John N.: Effect of Wavelengths of Light on Physiological Function of Plants and Animals, Illuminating Engineering Society April 1965.
- Pevsner, Nikolaus: An Outline of European Architecture, Prome and London, Butler and Tanner Ltd., 1975.
- Phillips, Derek: Lighting in Architectural Design, McGraw-Hill Book Company, New York, London, Toronto, 1964.
- Poffenberger, A. T.: Principles of Applied Psychology, New York, London, D. Appleton-Century Company, Inc., 1942.
- Porter, Tom and Mikellides, Byron: Color for Architecture, New York, Cincinnati, Toronto, London, Melbourne, Van Nostrand Reinhold Co., 1976.

- Pritchard, D. C.: Environmental Physics: Lighting, New York, American Elsevier Publishing Company, Inc., 1969.
- Rapoport, Amos: House Form and Culture, Foundations of Cultural Geography Series, Englewood Cliffs, New Jersey, Prentice-Hall, Inc., 1969.
- Raskin, Eugene: Architecturally Speaking, New York, Bloch Publishing Company, 1966.
- Rosmussen, Steen Eiler: Experiencing Architecture, Cambridge, The MIT Press, Massachusetts Institute of Technology, 13th printing, 1975.
- Ruskin, John: The Seven Lamps of Architecture, New York, The Noonday Press, a subsidiary of Farrar, Straus and Giroux, 1974.
- Sampson, F. K. and Jones, Bill P.: Illuminating Engineering Society, March 1964.
- Sakano, Noboru, Ueda, Saroski, and Seki, Masiyi: Pathological Disorders of the Eye Movements in Hemiplegics, Psychologia 1964.
- Sakano, Noboru: The Role of Eye Movements in Various Forms of Perception, Psychologia Vol. 6 1963.
- Sato, Kaji: Japanese Studies on the Transposition Problem, Psychologia 1957.
- Scientific American: Perception: Mechanisms and Models, San Francisco W. H. Freeman and Company, 20th edition, 1972.
- Sharp, Dennis (Ed.) with Benton, Charlotte, and Benton, Tim: Architecture and Design 1890-1939, New York, The Whitney Library of Design, An Imprint of Watson-Guptill Publications, 1975.
- Sharpe, Deborah T.: The Psychology of Color and Design, Totowa, New Jersey, Littlefield, Adams and Co., 1975.
- Simson, Otto von: The Gothic Cathedral, Origin of Gothic Architecture and the Medieval Concept of Order, Bollinger Series XLVIII, Princeton University Press 1974.
- Slivka, Robert M., Landis, Daniel, Jones, M. James, and Silver, Carl A.: Visual Search Time in a Structured Field, The Psychological Record 1968.
- Smith, Lester Kay: A Study of the Architectural Design of Six University Library Buildings, University of Southern California, Ph.D., 1973.

- Thompson, Godfrey: Planning and Design of Library Buildings, London, The Architectural Press.
- Thorninton, Luke, Parascandola, Louis, and Cuninghame, Lynn: Visual and Biological Aspect of an Artificial Sunlight Illuminant, Illuminating Engineering Society, October 1971.
- Uchiyama, Michiaki: Experimental Study on the Declining Process of the Form Field - The Field After Figure Disappearance, Psychologia 1960.
- United States Department of Commerce, Environmental Science Service: Weather Atlas of the United States, June 1968, reprinted 1975, by Glac Research Company, Michigan.
- Vitruvius: The Ten Books on Architecture, translated by Morris Hickey Morgan, New York, Dover Publications Inc., 1960.
- Ward, Herbert FIA (ed.): New Library Buildings 1974 Issue, London, The Library Association, 1974.
- Wickens, Delos D. W., Meyer, Donald R.: Psychology, New York, The Dryden Press, Publishers, July 1955.
- Wild, Friedemann: Libraries for Schools and Universities, New York, Van Nostrand Reinhold Company, 1972.
- Williams, Rollo Gillespie: Lighting for Color and Form, Principles, Equipment, and Applications, New York, London, Toronto, Pitman Publishing Corporation, 1954.
- Wittkower, Rudolf: Palladio and Palladianism, George Braziller, New York, 1974.
- Woodworth, Robert S., and Schlosberg: Experimental Psychology, Holt, Rinehart and Winston Inc., December 1965.
- Wurtman, Richard J.: Biological Implication of Artificial Illumination, Illuminating Engineering Society, October 1968.
- Yokose, Zensko: Theoretical Formula of Vector Field and Its Experimental Proof, Psychologia 1957.

TABLE OF CONTENTS

INFLUENCE OF THE WINDOW AREA UPON THE ILLUMINATION

ACKNOWLEDGEMENTS. iii

INDEX iv

LIST OF FIGURES ix

LIST OF TABLES xxi

BIBLIOGRAPHY xxiii

INTRODUCTION 1

PART I

. CHARACTERISTICS OF NATURAL LIGHT AND ITS INFLUENCE ON THE
DESIGN OF READING ROOMS 5

. INFLUENCE OF NATURAL LIGHT IN THE NORTH TEMPERATE ZONE
UPON DESIGN 10

. INFLUENCE OF NATURAL LIGHT UPON HUMAN PHYSICAL ACTIVITY
AND VISION * 13

. REVIEW AND CLASSIFICATION OF PREVIOUS STUDIES RELATED
TO THE SUBJECT 20

PART II

. MODIFICATION OF LIGHT. 25

. NECESSITY OF LIGHT MODIFICATION 27

. TECHNICAL MEANS FOR LIGHT MODIFICATION 50

. INFLUENCE OF THE WINDOW PROPORTION UPON THE QUALITY AND
QUANTITY OF LIGHT 138

. METHODS OF MEASURING THE QUALITY AND QUANTITY OF LIGHT
BY OBJECTIVE STANDARDS 142

* For a fuller discussion of these points see Appendices #I and II

CONTENTS

. DESIGN METHOD FOR MAXIMUM WINDOW PERFORMANCE. 150

. INFLUENCE OF THE WINDOW AREA UPON THE ILLUMINATION. 186

PART III

. CASE STUDY: INFLUENCE OF THE WINDOW SIZE, POSITION, AND REVEAL SHAPE UPON THE LIGHT IN THE INTERIOR 199

. APPENDIX I: PSYCHOPHYSICAL INFLUENCES OF NATURAL LIGHT 212

. APPENDIX II: BIOLOGICAL EFFECTS OF NATURAL LIGHT 233

. APPENDIX III: REFLECTIONS UPON THE INFLUENCE OF NATURAL LIGHT ON SPATIAL PATTERNS 237

. APPENDIX IV: ANALYSES OF THE CASE STUDY 255

The primary object of well controlled natural light. A sufficient quantity of light for reading is not of itself adequate. It is the distribution and character of the light which gives the quality of illumination which is instinctively perceived by man, as noted by Squire¹ who says:

"There is a strong demand for good natural light in spite of the considerable improvement in artificial lighting during the last few years. . . . The human vision is adapted to daylight and (that) consequently artificial light necessarily involves a certain degree of unfavorable adaptation."

This preference is confirmed in a recent study of six libraries in the United States of America² which shows that readers preferred the

¹E. G. Squire, P. Pennington, & J. Longmore: Daylighting, London, 1934, (Introduction).

²Center for Urban & Community Design, Architectural Design of Six University Library Buildings, University of Southern California, S.F., 1971, pp. 116, 124, 141, 142, 224, and 225.

INTRODUCTION

This study deals with the effect of the size and shape of windows and their reveals upon the quantity, quality, and distribution of natural light indoors, especially as these factors influence the design of reading rooms in moderately sized public libraries.

The desirability of natural light in reading rooms is supported by countless scientific studies and the stated preferences of readers. Though no library can do without artificial illumination, yet this light alone, no matter how well contrived, cannot provide the reading comfort of well controlled natural light. A sufficient quantity of light for reading is not of itself adequate. It is the distribution and character of the light which gives the quality of illumination which is instinctively preferred by man, as noted by Hopkinson who says:¹

"There is a strong demand for good natural light in spite of the considerable improvement in artificial lighting during the last ten years....The human vision is adapted to daylight and (that) consequently artificial light necessarily involves a certain degree of unfavorable adaptation."

This preference is confirmed in a recent study of six libraries in the United States of America² which showed that readers preferred the

¹R. G. Hopkinson, P. Petherbridge, J. Longmore: Daylighting, Heinemann, London, 1966, (Introduction).

²Lester Kay Smith: A Study of the Architectural Design of Six University Library Buildings, University of Southern California, Ph.D., 1973, pp. 316, 324, 342, 343, 254, and 355.

libraries which depend for their lighting upon natural light. Though there is as yet, no fully satisfactory scientific explanation for these preferences, it is the author's feeling that they stem from the animation that natural light brings into the interior.

This instinctive preference, however, does seem to have sound scientific support. For both physiological and psychological reasons, Watman³ and Brownfield⁴ urge the architect and lighting engineer to use natural light with its stimulating variety as contrasted to the enervating uniformity of artificial illumination.

The eye has evolved by adaptation to natural light. The varieties of its intensities, the moving of the clouds, the apparent shift of the orbit of the sun, and the dynamic quality of light and shade, these results cannot be imitated successfully by artificial means.

In order to define a "standard of adequacy" with which to measure the quality of interior light received from windows, experiments were conducted outdoors on the Campus to study the nature and proportion of the distribution of the natural light.

It became clear that pleasantness in an illuminated environment is governed far more by the relationship between the luminances in the surroundings rather than by their mere brightness.

It should be noted however, that there is a tremendous difference between the stimulus response to a room illuminated by artificial

³ Wurtman: Synchronization of Daily Endocrine Rhythms by Day-Night Cycles, Illumination Engineering Society, October 1968, p. 528.

⁴ Charles A. Brownfield: Sensory Deprivation, A Comprehensive Survey, Psychologia, 1964, pp. 63-93

light and to one which has access to natural light. The difference in the visual appearance is great. The appearance of the objects in both cases is not the same. Since every object reflects wavelengths in different proportions, and the artificial light is richer in some wavelengths than others⁵, the appearance of the objects will never be the same under both the natural and artificial light, unless both lights have the same wavelengths. This, however, is unlikely. Also, the differences in the spectral energy of the different sources of light do not appear as differences in the color of light itself, but as differences in the color of the objects themselves⁶. While the quantity of light necessary for adequate vision for reading and writing can be provided by artificial light as well as by natural light, nevertheless, the shadowless light from the luminaries will make it difficult for the reader to determine when the nib of his pencil will meet the surface of his writing page.

Our ability to obtain high levels of illumination by artificial means should not curtail our efforts to solve the problem of the penetration of natural light. As pointed out above, it can do so much to contribute to the comfort, well being, and health of persons using library reading rooms.

Architects, who have responded effectively to the other functional requirements of the library, would still benefit from a better

⁵ Derek Phillips; Lighting in Architectural Design, McGraw-Hill Book Co., New York, 1964, pp. 70, 72.

⁶ I. E. S. : Light and Color, Illumination Engineering Society, August 1969, p. 516.

understanding of the behavior of natural light in reading rooms.

This study attempts to further the understanding of the way light penetrates a reading room and to provide an effective tool to test alternative solutions during the design process. In order to do so, a series of experiments were performed on the Campus of the University of Pennsylvania.

These experiments, studies, and analyses enabled the author to extract the following criteria*:

1 - to determine the appropriate shape and position of windows for optimum performance, and to measure the influence of both the reveal shape and window proportion upon the quantity and quality of light in the interior.

2 - to invent a one-step methodology to measure the quantity of direct light reaching the reference point from any number of windows.

3 - to devise an easy method for anticipating the percentage of overcast sky on an hourly basis in the north temperate zone, from 32 degrees to 44 degrees North, during working hours, for windows of different shapes and orientations.

4 - to develop a tool to offer a solution for the problem of sun control and a technique to be used to achieve this.

* For psychophysical and biological influences, see Appendices 1 and 2.

PART I

CHARACTERISTICS OF NATURAL LIGHT

AND ITS INFLUENCE ON THE DESIGN OF READING ROOMS

Although natural light comes from all directions, it has a dominant direction. Even with a fully overcast sky, the zenith is 60 percent brighter than the horizon with respect to any reference point on a horizontal surface. Without this dominant directionality, it would be difficult for the eye to perceive real bodies, their texture, and dimensional solidity. In order for an object to be revealed it must stand clearly against its background and have a shadow of its own.

When the task has two dimensions (for example, when writing a page), light coming equally from all directions will render it difficult for the writer to estimate when the point of the pen meets the page. Without shadow, one loses his main guide to perception as Blumenfeld points out:

"A perfectly uniform brightness (and color) of the entire visual field would make all objects invisible"¹.

Architects can, by controlling light and shadow, clarify the different aspects of their buildings. By positioning the openings in relation to the task, they control the appearance of objects as perceived by the observer, whose movement or position conforms to the intention of the designer.

¹Hans Blumenfeld: An Integration of Natural Light and Artificial Light, Arch. Record April 1940, p. 51.

In special cases, such as in reading rooms, the proper control of the direction of light frees the reader's vision from glare. In the work of Sampson and Jones² with pencil tasks, their findings revealed that light coming from behind the observer does not remove glare, but is harder on the observer's eye than when some of the light comes from the front.

Another important feature of natural light is that its waves travel in straight lines. Without this feature, there would be a distortion of the whole environment visible to the human eye. For an image to be projected on the retina, every point of the source must be arranged on the mosaic of the retina in the same way as it is on the surface emitting the light. Any slight deflection of the rays would render difficult the locating of an object. The resulting illusion produced would cause disorientation.

As light travels in straight lines, architects are aided in determining where to anticipate receiving light from windows located in different positions.

Although light itself is not visible, the reaction of the opaque surfaces to light is perceived. This reaction depends upon the color lightness of the reflective surface. It is quite possible to increase the illumination of a room by an appropriate choice of surfaces.

²F. K. Sampson, Bill F. Jones: Illumination Engineering Society, March 1964, p. 187.

Because natural light is composed of different wavelengths, and surfaces absorb some waves with different proportions while reflecting others, the light reaching the eye differs in composition. The resulting light produces the sensation of color. If light were composed only of a single wavelength, the world would appear monochromatic with different shades, according to the direction and the angle from which it is seen.

Thus with the properties of reflection and color of light, it is possible to control the brightness and the mood of a room. Using interreflections, the contrast between the light coming from the windows and that in the far ends of the room can be reduced. This reduction in contrast helps reduce the glare. The quality of light in a room is judged by the relationships between the brightness of the different surfaces in the surroundings. Furthermore, discrimination of details under soft shadows is easier than under harsh shadows.

The mood in a room can be varied according to the reflected color of light. While a white finished room under artificial light would appear to produce homogeneous moods, under natural light it produces different moods. For instance, the light in a room on clear days is not the same as on overcast days. Furthermore, the appearance of the room changes as the sun moves, due to the shift in the peak of the spectral energy distribution³. When this shift reduces the amount of energy in any part of the spectrum, the light appears to have different colors with different luminosities. Though this feature

³R. G. Hopkinson, P. Petherbridge, J. Longmore: Daylighting, William Heinemann Ltd., 1966, p. 50.

cannot be employed in the design of lighting, nevertheless, the variability in the luminosity and color of light in a room is essential for the stimulation of the visual system. This also gives the interior the characteristics of external natural light. Hence, the occupants will not feel deprived of the external world.

It should be noted however, that architectural responses to natural light usually conform to the way light is distributed in the natural environment. The size of the window, its orientation, and its proportion contribute to the producing of these responses. For instance, in library reading rooms, if a window is situated in a western wall, the window should be supplied with appropriate sun breakers to avoid the penetration of the low rays of the setting sun. Also, the room shape and its internal dimensions are governed by the quantity of light that can be obtained from its windows. If the room's size is not subjected to the limitations of its windows, the light reaching the task will be inadequate. Furthermore, the quantity of the inter-reflected light that is essential for the improvement of light in areas remote from the windows would be affected. The room boundaries should receive direct light from windows in order to be able to bounce it back to the task efficiently.

Although the additive characteristics of light help to increase the illumination in a room, yet the uncontrolled freedom of creating many light sources is limited by the subsequent discomforts produced: glare discomfort, the appearance of many silhouettes, and the cumulative variable brightness on the objects.

Our goal must then be to take advantage of the abundant and in-

expensive natural light, to minimize its negative side effects, and to solve any problems that are associated with it.

Attention must be paid to the performance requirements of the reading spaces in the library, while at the same time, a pleasant atmosphere must be created to facilitate visual and psychological comfort and to contribute to optimum reader performance.

We should not regard the fluctuation of natural light as a drawback and a justifiable cause for the restriction of its use. Instead, it is an aid to improved vision and satisfies a biological and psychological need. The quantity of light available externally even under a totally overcast sky, is ten times greater than one actually needs in the interior for most purposes, while on clear days the light is doubled. Though it must be controlled to meet specific requirements, we would be at fault were we to design buildings without considering the implications of natural light by substituting artificial light. Artificial light is justified only when daylight ceases or where its employment is inevitable.

... of the sun. The design of the openings and their proportions will be related with the direction and intensity of the sun and the position of the sky cover. Other than with the appearance of these openings in the finished building. Even the layout of the buildings themselves and their relative height and spacing represent a decisive factor in dealing with the condition of light in any location.

... in the north hemisphere how included in this study were those a cloud cover ranging from 25 percent to 75 percent of the working hours of the day. These proportions are dependent upon the

INFLUENCE OF NATURAL LIGHT

IN THE NORTH TEMPERATE ZONE UPON DESIGN

Areas in the north temperate zone between latitude 32 degrees North and 44 degrees North in the United States of America are those which will be dealt with in this study.

Because the earth's axis is tilted 62.5 degrees to the plane of its orbit, buildings receive changing intensities of light throughout the year. This tilt of the axis causes the sun rays to fall upon the ground with different angles. The smaller the angle, the less light is received upon that plane.

Unlike buildings in the tropics, buildings in the north temperate zone receive sunlight only from the southern sky. Furthermore, horizontal surfaces do not receive normal rays of sunlight.

With this approach, different elements of architectural expression evolve to reflect the response of the buildings to both the intensity of light and the movement of the sun. The design of the openings and their proportions will be correlated with the displacement of the source and the condition of the sky cover, rather than with the appearance of these openings on the finished building. Even the layouts of the buildings themselves and their relative height and spacing represent a decisive factor in dealing with the condition of light in any location.

Areas in the north temperate zone included in this study experience a cloud cover ranging from 23 percent to 66 percent of the working hours of the day. These proportions are dependent upon the

month of the year and the degree of declination of the latitude.

The determination of the daylight levels in these regions is more dependent upon conditions of overcast sky luminances rather than upon direct sunlight. While the sun in tropical areas is nearly directly overhead during the working day, in the north temperate regions, the sun is less directly overhead, ranging between altitude angles 25 degrees and 80 degrees. This means that care should be taken to guard against the excessive brightness of the low sun.

The frequent cloud cover that these regions experience and the low illumination that results, make it necessary to employ the reflective properties of the interior surfaces to enhance the light in areas remote from the window.

On some winter days, the snow covering the ground causes a high level of reflected light to reach the eyes of individuals if not screened. Thus the technique of daylighting in this region will be a compromise between the admission of sufficient light and the elimination of unwanted glare and direct sunlight. However, improving the efficiency of windows would lead to a reduction in their sizes without affecting the general illumination of the interior. In such cases, devices for protecting the interior from direct sunlight would be simpler and more effective.

The important factor that determines the degree of success for a daylight design is to have a clear understanding of the lighting conditions of the region. This would be in terms of frequency of overcast sky, the relative luminance distribution of the overcast sky, and the sun's path with its azimuthal and altitude angles during

the working hours of the day.

In the north temperate zone, interior lighting requires both the direct and the reflected light from the sky since the sun is not the dominant factor in the design of interiors used for reading. Thus, the size of the windows will be affected by the area of the sky available in front of the windows, which in turn will be restricted by the height of surrounding buildings and their distance away.

The ground and the facades opposite the windows may have a reflectance of ten to fifteen percent of the light incident to them from the sky. This means that in overcast days, the light reaching the windows from such surfaces will be one-tenth to one-fifteenth that from the sky. Under such conditions, the ratio between the illumination in the interior to that received from an unobstructed sky could be taken as a useful factor in determining the relative luminances of the interiors in different locations, provided that the effect of the sun is excluded. On the other hand, on sunny days, the reflected light from the ground would be greater than that coming from a clear sky. Adding to these, the effects of the sun mechanism on the condition of light in different seasons and the need for light modification and control are crucial considerations for the design in the temperate regions.

INFLUENCE OF NATURAL LIGHT UPON
HUMAN PHYSICAL ACTIVITY AND VISION

Sight is the primary means for understanding man's relationship to his physical environment. His ability to grasp this relationship is directly proportional to the amount and quality of lighting - natural or artificial. To some degree, man's knowledge of a place may compensate for some reduction of the level of illumination. For example, a person in his own home can move around or descend poorly illuminated stairs with greater speed and confidence than a guest who is unfamiliar with the house. The less the individual is familiar with his surroundings, the greater is the need for an increase in brightness and clarity.

Clarification provided by light enables one to proceed in a task with certainty. The requirement for a high level of illumination is more pronounced when the task involves man-made materials, or is mechanical in nature. When discussing the activities of man, we have to distinguish between natural and mechanical tasks in order to understand the difference between the illumination needed for each. Viewing a natural landscape, walking, swimming, eating, or even interacting with other people does not require the same level of illumination needed for tasks of mechanical nature. In library reading rooms, for instance, the major task is reading and taking notes, which do not fall into the category of natural tasks. The books that are in use have different kinds of print, texture and color. In the manufacturing of these books, consideration was given to the availability of natural or artificial lighting. The sensitivity of the eye, its acuity, and

speed of assimilation were also factors that played a role in the determination of the final appearance of these books. Thus, these books came with the assumption of use under a particular range of illumination. Illumination engineers provided library reading rooms with stable levels of illumination by employing artificial light. This standardization of light and the mechanical nature of the tasks has, in the judgment of users, made visiting such libraries unpleasant. In a recent study of six libraries in the United States¹, readers showed preference for libraries which were naturally illuminated. Furthermore neurophysiologists have found that when an individual is subjected to a prolonged uniformly monotonous visual stimulus, he experiences a decline in energy, health and the feeling of well being². Moreover, it has been discovered that natural light is not only akin to the nature of man, but also its abundance increases his energy output. In explaining this phenomenon, Huntington studied the work output of three hundred men working in two naturally illuminated factories. He found that their work output increased with the increase of natural light available at the end of May³. Will an increase of artificial

¹Lester Kay Smith: A Study of the Architectural Design of Six University Library Buildings, University of Southern California, Ph.D. 1973, pp. 316, 324, 342, 343, 254, and 355.

²Charles A. Brownfield: Sensory Deprivation, A Comprehensive Survey, Psychologia, 1964, pp. 63-93.

³Building Research Institute: Solar Effects on Building Design, Publication number 1007, Washington DC, 1963, p. 4.

lighting increase human activity? The answer to this question is negative in that artificial light cannot be increased to the frequently available levels of daylight. For example, the average level of 3000 foot-candles of light was available in the campus of the University of Pennsylvania on a clear day under direct sunlight on June 20, 1979, at 1:30 P.M. Also, when electric light increases to just 125 foot-candles on the work plane, a definite feeling of discomfort from the infrared radiation of the incandescent lamps results. The same discomfort is felt when employing fluorescent lamps to produce 500 foot-candles of light on a horizontal plane⁴.

As man is oriented toward systematizing his universe, he has found in the rhythmic cycle of the day a means of regulating his biological functions as well as his physical activities. The cycle of day and night has encouraged man to be active and to rest at certain accepted intervals of time. This generally induced unity of behavior under natural lighting facilitates accomplishing of the necessary daily routines of man. Furthermore, the changing seasons of the year with their various lighting conditions add interest and color to life by producing an infinite variety of natural animation and visual stimulation. The level of human activity is influenced by these changing lighting conditions. Also a person's familiarity with the seasonal and atmospheric conditions in his immediate environment are part of his identity and subsequent feelings of security. In this respect, Gaudie wrote:

⁴Ibid., p. 5.

"One of the most foreign things about a foreign country, and one of the most homely about one's own, is the quality of its light. The intensity and angle of the sun, its constancy or fickleness, the expected hours of sunshine in the day or year, all enter in the sense of place..."⁵

The advantage of natural light lies in its capacity to illuminate the whole environment from a single source. If the lighting were insufficient to illuminate the area perceived by the eye, or if it originated from more than one source, the resulting light would irritate the eye and distort man's perception of the space. Furthermore, some portions of the visual field, which give cues to the viewer, would be obscured, and the viewer's expectations from past cognitive experiences would not be met. When the individual becomes aware of this ambiguity, he would first try to reconstruct and reinterpret his ideas according to experiences, culture, and knowledge familiar to him. If he failed to understand the reality of the situation, he would become disoriented and insecure, with concentration becoming impossible. Raynold (1960) and Sarbin (1964), in their cognitive theories of anxiety⁶, postulated that when the individual is unable to understand events or objects, he becomes anxious and changes his behavior to reduce this anxiety. Furthermore, the inability of light to reach distant parts of a scene distorts man's ability to estimate the real size of the surroundings from visual cues. Gogel (1974) concluded

⁵Sinclair Gauldie; Architecture, Oxford University Press, 1969, p. 133.

⁶Tom Porter and Byron Mikellides; Color for Architecture, Van Nostrand Reinhold Company, New York, 1976, p. 32.

that underestimation of the real distance causes underestimation of the size of objects viewed in the distance when compared to nearer objects⁷.

On the other hand, if the light comes from different sources, this will kill shadows, and it will be difficult for the eye to accurately perceive objects. The retina of the eye only perceives two dimensions of any object and needs other visual cues to formulate the third dimension. Experience has taught individuals an expected relationship between light and shadow. Changing this relationship can produce distortion and renders the environment unpredictable and even hostile.

Natural light has a combination of wavelengths, and the eye responds more to some wavelengths than to others. This means that visibility is dependent upon the composition of the light reaching the eye.

Since ambient light is the product of the light reflected from the surroundings, it is possible that visual fatigue can result earlier in some places than in others. This hypothesis has been examined only under limited conditions. For example, Ferre and Rand (1919)⁸ examined subjects reading under different colored lights and found that discomfort and loss of efficiency were dependent upon the char-

⁷Walter C. Gogel; Cognitive Factors in Spatial Responses, *Psychologia*, 1974, pp. 213-225.

⁸A. T. Pefferberger; Principles of Applied Psychology, D. Appleton-Century Company Inc., New York, London, 1942, p. 156.

acteristics of the dominant wavelength. They found that colors toward the red end of the spectrum are more favorable to acuity than the green end. When employing red light, the increase in acuity is from twenty to fifty percent more than under green light⁹.

It is commonly known that color contrast improves visibility, but Eastman (1968) demonstrated that a color contrast of more than sixty-five percent is of little importance to visibility regardless of the combination of colors. Furthermore, he concluded that in some instances, values of contrasts above certain limits may reduce visibility. He linked this to the condition of the color of the background. When a color is lighter than its background, the visibility level becomes less than when the color is darker than the background¹⁰.

One may be surprised to learn that designing a library reading room with different surface colors or with colored objects does not improve visibility. This is because the chromatic aberration of the eye's lens would focus the different colors. Some colors will be in focus, while others will appear blurred as the eye minimizes the effect of the blurred colors by constricting the iris to reduce their sizes (Kaufman 1974). This in turn, reduces the amount of light received by the eye. This phenomenon will slightly reduce the hours and days on which we can rely solely upon natural light.

⁹Ibid., p. 156.

¹⁰Arthur A. Eastman: Color Contrast vs. Luminance Contrast, Illumination Engineering Society, December 1968, pp. 617-618.

Another advantage of using natural lighting is that the interior becomes an extension of the exterior which, in turn, creates a feeling of openness. The activity in the interior is linked visually with that of the exterior, creating a harmonious relationship between the two spaces and giving the occupant a feeling of belonging and well being.

Furthermore, the direction towards which a window is oriented can induce various moods and emotions. For example, windows oriented due north tend to create a feeling of quiet coolness, while windows oriented due west tend to create a feeling of warmth and serenity.

In conclusion, when the goal is toward maximizing physical and psychological well being, natural lighting should not be replaced by artificial lighting. The presence of natural light in the interior and the resulting effect of openness is a crucial element in the design of artificial interior spaces. This is especially true in reading rooms where mental and physical activity are aided or impeded by the existing conditions of or by the manipulation of the lighting.

their work is usually based on qualitative requirements and programmatic objectives.

However, the solutions that have been proposed are mostly concerned of methods to be used in adapting the building to the existing conditions of light and direct sunlight. The approach is based on sensitive criteria, and the solutions are usually obtained by the aid of sophisticated tools. These solutions are summarized as follows:

1) They describe the conditions that characterize the light we require in terms of solar radiation, spectral distribution, color

REVIEW AND CLASSIFICATION OF

PREVIOUS STUDIES RELATED TO THE SUBJECT

Natural light, the coxombry of all the natural environment, has normally been of secondary importance in the design of library reading rooms. This was due to the following reasons:

a) the variability of natural light is uncontrollable,
b) windows are sometimes sacrificed in favor of a compact plan to reduce the rate of the heat exchange between the controlled environment in the interior and that of the uncontrolled outside.

c) there was no certainty that by the elimination of natural light from the interiors, the efficiency, health, and longevity of the deprived occupants would be affected.

Accordingly, very little work has been done specifically on the influence of natural light upon library design. Most of the solutions dealing with light were suggested by engineers who regarded natural light as an engineering tool, and the building as a regular box. Architects on the other hand, have produced ingenious solutions, but their work is usually based on artistic intuition and pragmatic solutions.

However, the solutions that have been proposed are mostly composed of methods to be used in adapting the building to the existing conditions of light and direct sunlight. The approach is based on normative criteria, and the solutions are mostly obtained by the aid of complicated tools. These solutions are summarized as follows:

1) They describe the condition that characterizes the light we receive in terms of solar radiation, spectral distribution, color

temperature, diffused sky light, reflection, refraction, absorption, and etc.

2) They recommend certain levels of illumination required for each task to achieve accuracy, acuity, and speed, without producing hazards, eye strain, or fatigue.

3) They also describe empirical methods to bring in soft light with some artistic criteria developed to assist the architect in controlling and introducing daylight by the employment of building elements and vegetation.

4) Extensive work has been done to solve the problems of glare, without the reduction of the level of illumination on the task, but this turned out to be very difficult because all materials exhibit some specularly.

5) They describe methods to solve the problem of penetration of light into deep zones by the use of tracking, by concentrating reflectors, and by light conduits.

6) They explained the tools used for light prediction and control. The basic one is a space angle-projection of the sky from which different protractors, tables and diagrams have been developed. Also, methods for calculating the interreflected component of light based upon the assumption that a room is a sphere. Therefore, the theory was called the theory of integrating sphere. There are also other tools which are complicated in their applications. Most are dependent upon perspective projection and what is known as component cards. This will be elaborated upon later in this study.

7) They describe the employment of certain kinds of glass treated chemically to have specific properties with regard to the ad-

mission of the amount of soft light and direct sunlight.

B) They describe the influence of the spectral energy upon the human health and his feelings of well being. This included the chemical and electrical reactions in both the eye and the brain to light. Stimulus orientation, fixation, color vision, adaptation, retinal induction, geometrical, optical, and kinetic illusion, space perception, constancy, after-image, the effect of aging, covariance, temporal gradients of responses to subliminal stimuli, and so on, are described.

Although the technical solutions cover most of the problem regarding the illumination with natural light, they are only effective when the design is completed. Architects usually modify their plans continuously until they achieve their goals in the design, besides, as the tools need complicated preparations before utilization, architects have disregarded those tools which fail to give an overall picture of the situation, since the results given are in terms of each window separately.

On the other hand, psychological research discusses hypotheses which only cast light upon certain observations about the human reaction to specific situations and conditions. Man, under laboratory situations, may respond differently than he would in the outside world. Factors such as pleasantness, contemplation, stress, and depression can modify all the results of laboratory tests. For example, pupil size of the human eye is specifically sensitive to the state of the mental condition, since all psychological and sensory stimuli, with the exception of light, dilate the pupil (Goldwater

1972)¹, This only indicates that it is not the light alone that controls the function of the iris when tested for such purpose. However, most of the literature in this group does not propose solutions, but discusses causes and effects of natural light upon the development of human culture. Architects disregarded this, too. 23

When employing technology, with only the problem of maintaining a stable level of illumination to be dealt with and considered to be the aim, neglected are the most tangible aspects of natural light, such as its influence upon health and vision, and the less tangible aspects such as the importance of natural light in contributing to a feeling of belonging and the variability of stimuli received from the outside.

Since we are dealing with natural light and its influence on the reading spaces, attention must be paid to the performance requirements of the reading spaces in the library, while at the same time, creating a pleasant atmosphere which facilitates visual and psychological comfort and contributes to optimum reader performance.

¹Bran C. Goldwater: Psychological Significance of Pupillary Movements, Psychological Bulletin, May 1972, vol. 77, no. 5, pp. 340-355.

INDICATIONS OF LIGHT

The aim of this chapter is to use the information described in Part I to solve the problems encountered in the employment of natural light in the smaller rooms of the library.

Because we are dealing with the north temperate zone, it is essential to indicate that methods that will be described here will essentially be different from those which are in use in different zones. The reason for this is that the intensity of light and the condition of the prevailing light in our zone is quite different from what would be found in other zones. For example, locations near the equator are characterized by clear **PART II** and sunny days. While the illumination of the sky as received on a window may be 500 foot candles, the reflected light from the ground outside this window because the ground receives direct sunlight of about 15,000 lm/ft^2 . When the average reflection of the ground is about twenty percent, the same window will receive a luminance from the ground four times that from the sky. The design for daylighting in this case must take into consideration that the main source of illumination is not from the sky, but rather from the externally reflected component.

In the north temperate zone the prevailing light is from the overcast sky and when the sky is clear, the direct sunlight is excluded, therefore in the design for daylighting in such a location, the basis of the design is the concept of the Daylight Vector, which is the

R. G. Holliman, F. Fothergill, J. Longwell, Daylighting, William Heinemann Ltd., London; Melbourne, Victoria, Calif. Edw. Bell, East, 1966, p. 119.

MODIFICATION OF LIGHT

The aim of this chapter is to use the information described in Part I to solve the problems encountered in the employment of natural light in the reading rooms of the library.

Because we are dealing with the north temperate zone, it is essential to indicate that methods that will be described here will eventually be different from those which are in use in different zones. The reason for this is that the intensity of light and the condition of the prevailing light in one zone is quite different from that found in other zones. For example, locations near the equator are characterized by clear blue skies and sunny days. While the luminance of the sky as received on a window may be 500 foot lambert, the reflected light from the ground exceeds this amount because the ground receives direct sunlight of about 10,000 lm/ft^2 . When the average reflection of the ground is about twenty percent, the same window will receive a luminance from the ground four times that from the sky¹. The design for daylighting in this case must take into consideration that the main source of illumination is not from the sky, but rather from the externally reflected component.

In the north arctic zone the prevailing light is from the overcast sky and when the sky is clear, the direct sunlight is welcomed. Therefore in the design for daylighting in such a location, the basis of the design is the concept of the Daylight Factor, which is the

¹R. G. Hopkinson, P. Petherbridge, J. Longmore: *Daylighting*, William Heinemann Ltd., London, Melbourne, Toronto, Cape Town, Auckland, 1966, p. 519.

ratio of the internal illumination, at any position, to the illumination as received on a horizontal plane from unobstructed sky. The effect of direct sunlight is excluded.

In this study, we are faced with both conditions. All factors that influence the light in those different zones, and a method applicable to the temperate zone with respect to the reading rooms in a library, must be included.

The amount of light required for good seeing and reading, and suitable comfortable amounts when not needed. In all cases, the structure itself should increase the quantity of light after its introduction to the interior. The reason for this is that the surfaces of the interior, though contributing to the internal reflected component, nevertheless absorb some of the introduced light. It is, then, very important to know the quantity and the quality of light needed for a certain task before proceeding in the design. For instance, a color film which is used for a space like a church pews to work in a library, though in both places, reading is involved. At the same time, excessive light may cause visual irritation and glare discomfort when not carefully controlled.

This means that we have to analyze the requirements for visual comfort in the reading rooms before any attempt is made to find the best means of light modification.

The primary function of light in a reading room is to provide the space with enough light to enable the reader to proceed in his task without eye fatigue or discomforting glare. This should be given special consideration, especially as the room is also used by groups such as the aged, visually handicapped, and so on.

NECESSITY OF LIGHT MODIFICATION

Daylight is fluctuating and its condition changes from season to season and from day to day, throughout the year. While on some days the light is intense, on other days it is not. We cannot change the condition of light as received from the sky, but we can modify it in the interior of our structures. We can introduce into the room the amount of light required for good seeing and reading, and exclude undesirable amounts when not needed. In all cases, the structure itself cannot increase the quantity of light after its introduction to the interior. The reason for this is that the surfaces of the interior, though contributing to the internal reflected component, nevertheless, absorb some of the introduced light. It is, then, very important to know the quantity and the quality of light needed for a certain task before proceeding in the design. For instance, a solution which is ideal for a space like a church ceases to work in a library, though in both places, reading is involved. At the same time, excessive light may cause visual irritation and glare discomfort when not carefully monitored.

This means that we have to analyze the requirements for visual comfort in the reading rooms before any attempt is made to find the best means of light modification.

The primary function of light in a reading room is to provide the space with enough light to enable the reader to proceed in his task without eye fatigue or discomforting glare. This should be given special consideration, especially as the room is also used by groups such as the aged, visually handicapped, and so on.

The secondary function of light is to enable the users of the space to perceive the whole reading room without unnecessary distractions, and to provide gradation of light, rather than patterns of different intensities, which may inhibit interpersonal communication and give rise to glare.

In considering the first function, investigation by Lythgoe (1932)² has shown that increasing the level of illumination increases acuity; the brightness relationship between the task and its surroundings determines the visual acuity. According to the Illumination Engineering Society, the luminance of a visual task which involved a simple object on a background can be equal to the luminance of the background³. For optimum visual comfort in performing the demanding tasks of reading and writing, it is recommended that the visual field of the reader be divided into three zones. The first zone is that of the reading material itself. It should be from 12 to 35 foot lambert. The second zone is that of the immediate surroundings. The desirable ratio of the brightness of the object of the task to the immediate surroundings is 1:3 to 1:1, with the minimum ratio of 1:5. The third zone is the general background with the desirable brightness ratio being from 1:5 to five times that of the task⁴. Such recommendations

²Derek Phillips: Lighting in Architectural Design, McGraw-Hill Book Company, New York, Toronto, London, 1964, p. 27.

³John E. Kaufman (ed.): IES Lighting Handbook, Fourth edition, Illumination Engineering Society, New York, 1966, pp. 2-9.

⁴I. E. S. : Luminance Relationship, Illumination Engineering Society, August, 1969, p. 513.

and most of the data in its final forms are based on experiments on human subjects. This means that though they are considered as standards, one may expect that some readers will consider them to be inadequate, while others can read within lesser levels of illumination. From Part I of this study, we have discussed how the human being can operate with some degree of efficiency under low illumination levels due to the adaptation mechanism of the eye to varying lighting conditions. The most essential goal in the design of daylighting is, then, to satisfy three conditions. The first is to provide the reading room with sufficient light, which can be achieved by the size of the opening, and the shape of the window reveal. One must remember that the light reaching the window is not uniformly distributed over the whole area of the opening. As seen in Part II the light reaching the lower half of the room is due to the light from the sky, while the lighting of the upper part of the room is dependent on the externally reflected component from the ground. If the part of the room above the middle of the window is receiving light from the ground and other external obstructions⁵, this means that raising the window as high as we can will permit most of the room to receive light from the sky. The contribution of the external reflected component to the illumination inside the room will be reduced to a

⁵ R. G. Hopkinson; Architectural Physics, Lighting, London, Her Majesty's Stationery Office, 1963, Part I, Chapter 7, p. 88.

minimum, thus it will follow that lowering the window will maximize the effect of light reflected from the ground and minimize that reaching it from the sky. While in the latter case, the color and the intensity of light is determined by the reflectivity of the constructed external environment and the color of vegetation or natural materials on the ground. The distribution of light in the former case, with the window near the ceiling, is quite different in color and magnitude as it reaches the table top directly from the sky. The penetration of light through the window into the interior is predictable and directional, while the light reaching the ceiling from the ground gives diffused light, which spreads over the working plane. It cannot be easily predicted, owing to the changing circumstances of land use and the variability of the shadow cast on the ground from the buildings in the locality.

There is another aspect which affects the quality of light and thus reduces the effectiveness of increasing the level of illumination. Unfortunately, this aspect cannot be seen by the human eye, but its effect causes inconveniences in acuity and ease of discrimination. As noted in the previous chapter, the actual amount of light falling on an object is not available to a person's perception, but the brightness of an object is judged by its albedo. This does not mean that the path of the light rays from the source to the object will have no effect on the clarity of that object as seen by an observer. This depends, of course, on his location with respect to the object and light source. To clearly illustrate this point we have to exaggerate the condition and then return it to its original case. Now, suppose

that there is a room with walls of very low reflection with the window opening admitting direct sunlight onto a print located on a table; if the sun rays were made visible by filling the room with smoke, they could be easily seen against the background. When these rays intercept the person's line of sight to the opposite wall, they reduce the visibility of that part of the wall masked by the bunch of rays. In the same way we will see that the print can be easily read sideways or facing the window. In actual cases where sun is excluded, the eye senses these variations, but since it acts as a filter, we do not perceive them; instead, we unconsciously choose the location more comfortable to the eye. This principle answers two questions: first, why readers prefer a light source from their side, and second, why they prefer to read on the periphery under direct skylight, rather than directly under it. This may lead us to the conclusion that for optimum visual conditions, the angle between the incident light and that reflected to the eye should not be acute. Accordingly, the direction of light must be modified to meet this condition.

Regarding the level of illumination required for reading, it should be noted that while increasing the level of illumination will result in an increase in acuity, Weston has shown that the increase in illumination from 100 ft-c. to 1000 ft-c. will not improve acuity by a remarkable degree⁶. According to Phillips, increasing the

⁶ Derek Phillips; Lighting in Architectural Design, McGraw-Hill Book Company, New York, 1964, p. 27.

illumination on a difficult task will not let the performance be equal to that of an easy task with lower intensity⁷. In our case, the difficult task is writing with pencil or reading a page written with pencil.

According to Phillips (1964)⁸, the required level of illumination can be obtained by dividing the brightness of the task (which can be determined from the size of the detail) by the reflection factor (which is the percent of light reflected from the highest reflecting surface of the seen detail). By the use of the following formula, the brightness of any object can be obtained:

$$180S - 1.5 \text{ ft. lambert}$$

where S is the size of the detail in minutes of arc. For the determination of S, multiply 3.435 by the actual size of the detail, measured in inches, and divide this by the distance between the eye and the object, providing this distance is not less than 12 inches.

According to the British code (1961) the minimum level of illumination must not be less than 15 ft-candle, even if the computed level of illumination is less than 15⁹.

However, this computation is based on the assumption that the person has normal vision. In the case of visual impairment due to age or disability, more illumination is required for the person to perform the same task. Also, it is assumed that the lighting condi-

⁷ Ibid., p. 28.

⁸ Ibid., p. 28.

⁹ Ibid., p. 29.

tions are free from veiling reflections and sources of glare. This will be dealt with in the discussion of the means of light modification, later on in this study.

The second condition for good daylighting design is the control over the distribution of light in the reading room. As a general rule, it should be emphasized that the presence of the source of light in the field of view of the reader can not be compensated for by any additional illumination. There must be an angle of separation between the rays of light reaching the eye from both the window and the reading material. According to Phillips¹⁰, when the angle of separation is about 40 degrees, veiling reflections are considerably reduced, provided that the brightness of the source is not excessive.

The object of the distribution of light is therefore to create a pleasant environment without forcing the eye to adapt to different intensities of light, while at the same time, avoiding the unpleasant uniformity of light. To lessen the impact of veiling reflections and thus ease performance, the following technique should be taken into consideration:

- 1) reduce the size of the window,
- 2) reduce the window brightness by technical means (for example, by providing it with horizontal louvers),
- 3) enhance the reflectivity of the surrounding walls, and
- 4) increase the angle of separation between the task and the source.

¹⁰ Ibid., p. 37.

Glare discomfort, another defect caused by the presence of shiny surfaces and glittering objects, cannot be measured in photometric terms, but the physical factors which cause it can be estimated by subjective assessments. For example, one reader may be comfortable in a place with lesser illumination because he experiences no visual distraction from a window, or from a high glossy surface. On the other hand, another reader in the same reading room in another position may be distracted by the brightness of the sky from the window, although the lighting for reading is satisfactory. While the one is satisfied by the lesser illumination, the other not only complains about unfavorable lighting conditions, but also considers the other person to be reading in the dark.

Hopkinson indicates that to evaluate glare sensation, one must not approach it from the subjective intensity of the brightness, but rather, from the factors which cause glare discomfort. These factors can be summarized as being due to the brightness of the sky, its size, and its position as seen by the reader, and finally, due to the condition of the average luminance of the room's interior¹¹. The greater the contrast between the brightness of the window and that of the interior, the more discomfort will result.

Since the remote parts of the room depend on their illuminations from the interreflected light more than directly from the window, the

¹¹ R. G. Hopkinson and others: Daylighting, Heinemann, London, 1966, p. 307.

levels of illumination at these areas will be much less than the illumination at points near the window. Accordingly, the probability of discomfort will be great owing to the adaptation required in each case. It is necessary then, that provisions should be made so that those dim areas in the room receive light from secondary or clerestory windows.

Hopkinson proposed a formula which is a modification of the B. R. S. Glare Formula¹². This is intended to be suitable for computing glare resulting from large sources. The modified B. R. S. Glare Formula is:

$$B^{1.6} \delta^{0.8} = G (B_D + 0.07 W^{0.5} B_S)$$

where B_S is the brightness of the source in ft-lamberts

W is the solid angular subtense without modification

δ is the solid angular subtense of the source after being modified for its position in the field of view. This can be determined from Petherbridge's solid-angle diagram.

B_D is the brightness of the surrounding field alone

G is the appropriate value of Glare Constant, midway between just uncomfortable and just acceptable glare.

Though it appears simple, this formula cannot be used in the design process; if it is applied after the building is completed, it will not solve the problem of glare. The reason is that B_S , W and δ are variables with infinite possibilities and becomes further complicated if the room has several windows and/or the reader moves his head in

¹²R. G. Hopkinson: Architectural Physics, Lighting, London, Her Majesty's Stationery Office, 1963, Part II, Section IV, p. 231.

several directions.

Thus it will be more convenient if models can be made and tested both visually and photometrically before execution on the site. This also indicates the necessity of using structural and landscaping techniques to reduce the detrimental effects of glare in the reading rooms.

Another aspect which influences the distribution of daylight in the reading room is the physical setting of the window openings. A window, while emitting light, may at the same time, correct defects caused by other windows. For instance, an adjacent window illuminates the wall containing the other window and reduces the brightness contrast between that window and its wall. At the same time, it adds illumination to the reading room since light is additive in nature. In spite of this, the adjacent window may cause visual distraction to the reader if its location is not correctly determined.

The shape of the window also determines the distribution of light in the interior. For instance, a ribbon window will give even distribution of light in the area near the window, while light ceases to penetrate further in the room due to the low angle of incidence and to the reduction in the area of sky viewed from the interior.

In the case of tall windows designed as vertical strips in the wall, the distribution of light near the window will not be as even as that of the ribbon window with the same area of glass. Nevertheless, the penetration of light into the interior will be deeper and evenly diffused near the middle third of the room as light fans out

once penetrating a window.

Splaying the window reveals to the interior will reduce the brightness contrast between the tall windows and the parts of the wall separating them as the light distribution is graduated in brightness. Splaying the window reveals to the exterior will result in a marked increase in the quantity of light admitted into the room. This will be further detailed in the last chapter of this work.

Windows occupying the whole area of the wall admit more light but create difficulties in how to protect the interior from sunlight and excessive luminance. This and all the above mentioned situations will be dealt with in the section discussing means of light modification.

Direct and indirect skylights and clerestories, if well designed, will give even distribution of light over a large area of a horizontal surface, if they are positioned so as not to distract the reader or to prevent him from concentrating. Such skylights are not efficient for showing details of three dimensional objects in the interior but do not affect lighting for reading and writing on a two dimensional plane.

The third condition for good daylighting is the reflective characteristics of the materials used in the artificially built environment.

You will see in Part II that observations based on actual experiences in architectural projects¹² have shown two im-

¹²Buildings executed and supervised by this author.

portant characteristics; first, the employment of surface color on walls and ceilings reduced both the quantity and quality of light, and second, the quantity of light was markedly improved with increased reflectivity of the boundaries of the room. Though photometric measurement may have indicated that the quantity of light increased by about 20 percent, the perception of light will be an incredible increase. I have drawn these conclusions from observations of buildings executed under my supervision in different sites, heights, and orientations in Egypt. The rooms were first built with red bricks, and then were coated with plaster of Paris. This coating helped reduce glare because the brightness of the adjacent walls were enhanced by reducing the contrast between the window brightness and the general background as the plaster of Paris reflects about 75 percent of the light incident upon it.

There is another important point which affects the distribution of light due to reflections. It is commonly known that matt surfaces diffuse light incident upon them in all directions. This affects the control of the behavior of light in rooms and has led some researchers, like Hopkinson, to consider the room to be a sphere to obtain an empirical formula for use by architects. The basic formula is:¹³

$$\frac{\text{Average interreflected component} = \text{first reflected flux from interior surfaces}}{A(1-R)}$$

¹³R. G. Hopkinson: Architectural Physics, Lighting, London 1963 Chapter 7, p. 88.

Where A is the average reflection factor of all the boundary surfaces in the room, and where R is the average reflection factor of all the boundary surfaces expressed as a fraction of unity.

This formula is useful in determining the contribution of the interreflected light to the lighting of the interior. However architects need a method to help them direct the reflections to certain locations where they are more desirable.

To illustrate this principle, two experiments were conducted. In the first experiment, a rectangular mirror and a piece of white cardboard of equal size were used. Light from the window was permitted to fall on the mirror. This light in turn, was reflected back to vertical white pipes near the floor, arranged to form patterns of light and shade against a dimly lit part of the wall containing the window. The area lit by the mirror was then marked. When the mirror was replaced by the white surface of the cardboard, the same area illuminated by the mirror received light from the cardboard, but with lower intensity. In the second experiment, different samples of cardboards of different colors and textures were used. With the aid of a light meter and a source of light, the specular angle of each was measured. The results observed from both experiments showed that the light incident on matt flat surfaces is reflected in two ways, diffused light in all directions with very low intensity, and reflected light following the law of reflections. This reflection constitutes the principal intensity of the reflected light and should be considered an important factor in the directionality of light, especially in designing with sunlight. The reason for this is, the declining rate of artificial light, after leaving the source, is higher than that of the

natural light. For example, the level of illumination as measured near the surface of a 40 watt fluorescent lamp is 1000 ft-c. At a distance of three feet below this lamp, the intensity becomes about 50 ft-c. In the case study for a fixed size of window and room, a comparison was made of the results obtained from the employment of natural light and artificial light. Though the level of illumination at the external surface of the window was maintained at 1000 ft-c. in experimenting with artificial light and at an average of about 400 ft-c. in experimenting on overcast days with natural light, the percentage of light received in the interior at a point near the window was about twice as much as that produced by artificial light at the same point. Another observation worth noting is that the intensity of the light in remote parts of the room produced by artificial and natural means is identical even though the level of illumination at the exterior of the window was not identical. The reason for this is that the remote part of the room, being masked from the sky, depends for its lighting on the interreflected component. On the other hand, the artificial light was homogeneously distributed over the whole area of the opening, and direct light from the artificial source reached every part of the room. Although the natural light source is less in foot-candle magnitude than the artificial light source, the resulting interreflection is the same intensity. This supports the hypothesis that when employing daylight, as a source of illumination for interiors, matt surfaces will act like mirrors of low reflection factor. This helps the architect to direct light from the adjacent surfaces of windows to the remote parts of the room.

It must be emphasized here that directing light by reflecting surfaces, if not well controlled, can cause serious problems to the distribution of illumination and to the adaptation mechanisms of the eye. When additional illumination reaches a dim part of the room, this illumination increases the brightness of the objects in such a location and also intensifies the shadow cast on the immediate surroundings. This causes uneven distribution of brightness, and the dark shadows that result will make other objects that were previously visible under a lower level of illumination cease to be detectable under the new circumstances. Consequently, the eye finds it difficult to adapt to this situation and will attempt to locate the source of such brightness. The eye will then turn to the expected source of brightness only to discover it to be a source of glare.

Another aspect is that if such reflection comes from a lower level, anyone who intercepts the rays will render the situation worse. For reasons such as these, it is of utmost importance that the light that is reflected to the remote parts of the room should be from multiple positions. Also, the surfaces in the remote parts of the room should be light in color and free of obstructions, such as bookshelves or paintings.

However, should necessity dictate the need for such objects, they should be placed not higher than the reading table level. Furthermore, the tops of these surfaces should be of light color so they enhance rather than absorb the light.

The tops of shelves or tables used by readers and are in plane lower than their eye levels should be light grey so as not to distract

the reader as contrasting colors would. Light grey is considered the appropriate color for the problems of lateral inhibition, contrast sensitivity and chromatic aberration. Such problems are discussed in detail in Appendix I. Also, light grey contributes to the quantity of the interreflected light.

It should be borne in mind when designing with daylight that though bright surfaces enhance the quantity of light, and its distribution, nevertheless, the differences between the brightness of such surfaces should not be great. Otherwise the eye will be constantly drawn to the brighter surfaces. At the same time, dull uniformity should be avoided since it produces monotony and boredom.

Little attention has been directed toward the influence of the floor's reflection on the illumination of the interior. The reason is that the assumption was made that the floor would be carpeted or occupied by heavy furniture, as in former times, when wooden tables and chairs had bulky cross sections and were massive in size.

Nowadays, furniture is light, movable, and spaced comfortably apart. Similarly, windows were formally spaced by large piers and ceilings were higher so that any reflection from the ground would not increase the illumination of such ceilings. Also, the effect of the floor finish on the interreflected light was disregarded in favor of producing an emotional response from the eloquent atmosphere of the room.

When we know that light from the sky is more intense than the reflected light from the surroundings and that the latter falls directly on the floor, we will realize the importance of taking full advantage of such a situation.

Though good interior lighting can be achieved without the employment of surface color, which is unnecessary as a parameter, some architects regard color as essential for the visual environment. For this reason, color and light must be studied together since the reflective component is modified by the reflective characteristics of the colored surfaces. Hence, the quality of the color of the total environment is affected. The influence of white light on the appearance of the colored surfaces has been discussed in Appendix I. However, here the study will be confined to the influence of white light upon colored surroundings without reference to colored light as this, along with color naming, its effect on the activity and the feeling of well being for the readers, was also discussed in the same Appendix.

In this study, the Munsell system of reflectance value and Hopkinson's findings will be applied¹⁴. Munsell has adopted a means of measuring the visual appearance of colors in terms of lightness. Any color which gives the same reflection as another color is regarded as having the same lightness and is given a number. Therefore, any surface colors, which have the same Munsell numerical value, reflect the same quantity of white light although the reflected light will be different in color. He adopted a formula to compute reflectance, as follows:

¹⁴R. G. Hopkinson: Architectural Physics, Lighting, London 1963, p. 110 f.

$$R = V (V-1)$$

where R is the percentage of reflectance of white light

V is the Munsell value

For example, a surface color of Munsell value 8 will reflect 8 (8-1)= 56 percent of the incident white light regardless of the color's name. Munsell then gave numbers to the appearance of the color of the reflected light as a whole and named such grading by chroma. For example, if two surface colors are red and green and have the same Munsell value of 5, but the red has chroma 12 and the green has a lower chroma 6, according to the Munsell System, both colors will reflect 20 percent of white light. Nevertheless, the reflected light from the red surface will be distinctively reddish while the reflected light from the green surface will be slightly greenish.

The British Standard Color Range (B.C. 2660) has arranged 101 colors and classified them similar to the Munsell System, and has arranged them in terms of white light reflectance¹⁵. This gave architects the freedom to choose colors, while at the same time, giving them an opportunity to fulfill the requirements of reflected light quantity, according to the standard level of illumination specified by the Illumination Engineering Society.

Hopkinson suggests that the necessary amount of reflectance to maintain appropriate level of daylight is achieved when the ceiling has a reflectance of 70 percent. This can be obtained by coloring

¹⁵ Ibid., p. 112.

the ceiling with a color having a Munsell Value of 9, and when the walls have a reflectance of 55 percent or Munsell Value 8, and when the floor has a reflectance of 40 percent or Munsell Value 7¹⁶.

In fact, to my thinking, the Munsell System is essentially meant for use in the comparison of value and chroma of different colored samples so that they can be manufactured and produced with certain specifications. On the other hand, when colors with their specifications are used in the interiors of the rooms, the finished work is quite different than the original sample. For instance, the color once used on the walls appears not only darker than the sample but also different in color. In practice, I found it very difficult to predict how a room will appear after it has been painted with colors. I suggest that the reason for this is that most experiments on colored surfaces were done according to the results of the first reflection without considering the influence of the interreflections that occur continually until absorption is complete. The eye is unable to distinguish between the nature of the light illuminating such surfaces and the basic color of that surface. Colors in the remote dark corners of a room appear dull, whereas in the highly illuminated zone, they appear brighter and have vitality.

As has been discussed in Appendix I, colors always change when they are surrounded by other colors. The question is now whether the Munsell Value and chroma can be successfully applied in the field of architecture or whether another workable system should be developed.

¹⁶Ibid., p. 110.

In fact, architects may be reluctant to the idea of painting the darker parts of the walls with a higher Munsell Value and Chroma to compensate for the drawbacks in the appearance of colors¹⁷ in those parts of the room, and hence the poor quality of light. Shadows change in lightness or darkness according to the time of day and the condition of light during that period of time.

Instead of involving ourselves in controversies as to which colors and compensations to choose in varying circumstances, this author would suggest that white is the most appropriate substitute, as it never becomes dull in areas of lesser or greater illumination. However, designing the interior with white surfaces is not as simple as might be expected. The reason is that the white interior exposes the reality of space without the illusion of depth, or the change in the appearance of the objects if moved from one place to another. It would be a good idea to give the interior some plasticity so that the gradation of white light on white surfaces give the impression of unity and coherence.

Munsell Value is graded from 0 to 9, that is according to the formula from 0 percent to 72 percent reflectance of white light incident upon the surface. Realizing that the Munsell Value 9 is for light pastel colors which approach white, and considering the maintenance factor, oxidization, and pollution from the environment, the conclusion will be that to achieve a certain level of daylight factor, while at the same time, fulfilling Hopkinson's prescription for certain reflectances for room surfaces, the architect has to provide

¹⁷ Ibid., p. 111.

supplimentary artificial lighting for the areas that have low illumination levels or to repaint the surfaces frequently. When employing artificial lighting, colored surfaces would not appear the same as under natural light. The subjective reaction to brightness would be greatly affected according to Hopkinson¹⁸, because increasing the amount of energy will cause variations in brightness in a nonlinear manner, that is, equal changes in luminance do not lead to equal changes in subjective brightness. Thus, for a given environment, there is an acceptable level of brightness relationships in the surroundings, which the eye can tolerate without feeling discomfort.

There is a relationship between the visual sensory response and the brightness of surface color. Since colors vary in their Munsell Value, there will be situations where light reflected from surface color in the shadowed parts of the room may not be sensed by the eye at that instant, though reaching the eye, because of the adaptation of the eye to the amount of light energy in the room. These rays of light may be falling on the eye, yet not perceived, as they are below the threshold of sensation in that particular situation.

However, this problem and other problems related to vision and subjective brightness demand a scale to be applied in practical situations. Weber and Fechner¹⁹ have studied the relationship be-

¹⁸ R. G. Hopkinson: Architectural Physics, Lighting, London 1963, p. 324.

¹⁹ Ibid., p. 326.

tween brightness stimulus and sensation. Weber stated that just noticeable differences in sensation result from equal ratios of stimulus, while Fechner stated that equal intervals in sensation are proportional to equal ratios of the stimulus. Abrihat (1935) formulated a subjective brightness scale using the Weber-Fechner method which Hopkinson²⁰ also employed to formulate his proposal for a standard scale of apparent brightness. He linked luminance with adaptation to produce scales of apparent brightness. He did not include the effects of simultaneous contrast and brightness constancy, because such factors are associated with the geometry of a visual field. He suggested that local corrections may be done in the interior and that his formula can be adopted without serious practical error. His standard apparent brightness scale is computed as follows²¹:

$$\text{Log } M = 2.65 + \frac{\text{Log } L - 4.40}{1.75 - 0.314 \text{ Log } A}$$

where M = apparent brightness magnitude of area under study

L = luminance (ft-lamberts) of area under study

A = luminance (ft-lamberts) of adaptation level.

His formula is based on the assumption that in conditions of excessive brightness, apparent brightness is directly related to luminance.

This formula is not effective under relative dark conditions, because in a very bright condition, a luminance change of 2:1 will be sensed

²⁰ Ibid., p. 326.

²¹ Ibid., p. 341.

by an observer as a change of the same proportion, while under a very low brightness condition, an apparent change of 2:1 requires more than a 5:1 change in luminance²².

Since the brightness constancy and simultaneous contrast were not included in the formula, the direct application of this formula will not be effective without local corrections.

Using white as the color in the whole interior means a high percentage of reflectance, about 80 percent, and this might dilute the problem with the resulting gradation of light and its hue being satisfactory.

²²Ibid., p. 341

²³The coefficient of utilization is the ratio of the illumination at a point on a reading plane, relative to the illumination available at the window opening, in cases where the freedom of changing the window area is restricted.

TECHNICAL MEANS FOR LIGHT MODIFICATION

The objective in this chapter is to conclude with partial solutions to the problem of illuminating the reading room of a library with the available natural light, using simple methods which can be adopted by architects especially during the design phase, which frequently entails changes of the distribution of the elements in favor of factors other than illumination alone. The concurrent objective is to find a method to enhance the penetration of light or, in other words, to increase the coefficient of utilization*. Inevitably, illumination of the remotest parts of the rooms will result.

It should be borne in mind that increasing the light within the boundary of the room does not automatically mean achieving a successful solution, since the importance of the relationship among the different brightness of surfaces far exceeds the value of such increase. As we have seen in previous chapters, the reason for this is that the eye has a range of adaptation to certain brightness gradations which, if interrupted by sudden increase in brightness, will lead to eye strain. This will in turn cause depression and physical fatigue. Therefore, for any lighting design to be successful, the quality of light should not be sacrificed for the quantity, nor should the latter be divorced from the former. Each must have its role in serving the function, neither should mar the other, but should equally contribute

*The coefficient of utilization is the ratio of the illumination at a point on a reading plane, relative to the illumination available at the window opening, in cases where the freedom of changing the window size is restricted.

to the balanced distribution of brightness.

Part of this chapter will be devoted to the discussion of lighting quality, enumerating different methods to achieve this goal.

Since we are dealing with natural light in the northern temperate zone, which is characterized by its different climatic changes, it is necessary to develop more than one method in the phase of analysis. Later, after everything has been clarified separately, both will be combined to form a coherent solution applicable to different lighting conditions without militating against each other.

It must be noted that extensive research has been done in the science of lighting by Illuminating Engineering Societies and by American, Australian, English, and French authors. Their findings and publications will be referred to wherever appropriate throughout this discussion. A list of their publications is also incorporated in the bibliography.

The approach of this study will be slightly different from the current ones, in that it will reveal some aspects which have been previously left uncovered. Some of these include the influence of the window reveal upon the quantity of light on a reference point in a reading room, and the role of the boundaries in determining the behavior of natural light in rooms. Also, new data will be included, and simplified methodology to be used by architects who are by nature, reluctant to use the intricate geometrical formulas put forward by Illuminating Engineers who in most cases write about natural light with a lamp in mind. This is due to the variable condition of the natural light, and the variable factors, none of which can be fixed to permit control by means of a single formula. The protractors that

are available are many, however, none of them can give an idea as to what the size, shape or location of a window should be in introducing a certain amount of natural light in the interior. Instead they are designed as a checking tool to fulfill the requirement of the building code, usually after the design has been completed.

The author's goal is to develop protractors which permit freedom of choice in the matter of window location and size which, at the same time, do not require laborious drawings and preparations.

This study's findings will be empirical and derived from experiments done on scaled models and photometric measurements.

Emphasis will be upon the quantity of light received by a book either horizontally or tilted, without much emphasis upon the appearance of the display within the boundaries of the room, upon dramatization of the circulation, or upon certain parts of the compartment. The following discussion will be more scientific than artistic and hence it may not cover the requirements of other buildings which differ in function and utilization. Furthermore, this study should not be regarded as a reference in the matter of illumination, but should be regarded as an aid to those who seek use of natural light to facilitate vision in a pleasant atmosphere.

This study is based upon data obtained during 1931-1960 from meteorological stations in different latitudes distributed throughout the United States of America¹. This data was recorded by black-bulb

¹ U. S. Department of Commerce, Environmental Science Service Administration; Weather Atlas of the United States, June 1968, reprinted 1975 by Gale Research Co., Michigan, pp. 190-207.

type sunshine recorders and selected to cover latitudes from 32 degrees North to 44 degrees North, which is the geographical range of this study.

Both American and English methodology will be the basis of designs since extensive studies have been done in England by R. G. Hopkinson, P. Petherbridge, J. Longmore, J. D. Kay, and others, with respect to the overcast sky condition prevailing there. As the American method of using direct sunlight is more advanced, it will be adapted in this study using the works of Derek Phillips, Victor Olagay, John Flynn, and others.

It should be noted that although this study has been conducted in the United States with its unique natural lighting conditions, nevertheless, the findings can be applied elsewhere, provided that the variables are modified to reflect the actual conditions of each locality.

Clarification of some aspects is needed before dealing with the technology which guides those contributing to reading room design, using daylight as the main source of illumination.

The major aspect needing clarification is that the author's aim is not only to provide the reading room with adequate light, but also to meet the general and individual needs of the readers. If the reading room is to function effectively, it should resemble a room, conform with a person's expectations of a room, and be characterized by readily identifiable walls, ceiling, and floor. Therefore, in considering the level of illumination at the reading plane, the boundaries of the room must be differentiated from each other by brightness

levels. Man cannot tolerate reading in a room where the boundaries to which he customarily orients himself have been perceptually removed. Another point is that while we meet the standard of visual comfort, we should observe the individual differences of age and visual capabilities. Furthermore, the need for visual rest centers to gaze at must be made available, as we cannot assume that a reader's task is only to read with concentration. There must be some moments for pause, reflection, and gazing around the room. If this is not present in the design, this will evoke negative reaction; the space, though skillfully furnished with light, will be repulsive and will assert itself in a manner unendurable even to those whose readings have not been started.

Before designing for daylighting, the author recommends study of the Appendices discussing physical and psychological perception, as these rank as equal in importance to the design itself.

The problem of glare is still the first enemy of the designer and has exhausted those who have tried to tackle it. This problem has not arisen from light itself, but it is a cause which has been created by us. Part of this chapter will be devoted to the cause and effect of glare and what we can do to dilute its negative effects until it disappears as a result of advanced technology.

Having defined the objectives of this study, the next step is to begin discussion of the technical means for light modification. We know that light reaching a reference point in a room is different in intensity than that reaching a window, though the latter determines the quantity of the former. Light reaching the window comes

from various sources: the direct sunlight, light scattered from the sky, and light reflected from the ground or opposite buildings. Its quantity is directly proportional to the window size and the reflectances of the surfaces of the environment. The light reaching the reference point varies, according to the position of the point with respect to the window, and the efficiency of the surrounding surfaces in bouncing the light back to the point in question. Points along the window axis receive light more than those not in view of the window. Increasing the size of the window may reduce the working surfaces and the amount of reflections. To compensate for these disadvantages, it is necessary to make provision for bouncing the light back to the work plane in order to provide it with a sufficient amount of light, especially in areas remote from the window. Accordingly, the surfaces of the interior, which receive direct light from the window, must have high reflective properties and be located as near as possible to the work plane. Since the light waves travel in straight lines and since any building material reflects light near its specular angles, it is possible to apply the law of reflections in handling the design of surfaces with respect to the angles of incidence. This will serve for the initial reflections, but since these surfaces are adjacent or opposite to each other, and since light travels with speed from surface to surface and is reflected back again multitudes of times without losing much of its energy, interreflections occur and these interreflections help increase the amount of light in the space. This is beneficial to those parts which have no direct exposure to the window. The amount of this increase will be discussed later on in this chapter. Thus the difference between the light

reaching the window and that reaching the reference point is, that the window receives light directly from the outside sources, while the reference point receives light directly and indirectly. According to the B. R. S. Split-flux theory², the window is divided into two halves, upper and lower. The upper half illuminates the lower section of the room under the line of division, and the lower half illuminates the upper part of the room over the line limit. The upper half of the window receives light from the sky, if not obstructed externally; the lower half of the window receives its major light from the ground and external surfaces. This means that the higher the window sill is above the floor, the greater will be the area of room boundaries reaching light directly from the sky.

According to the split-flux theory, an equation was introduced to represent the basis for the computation of the internally reflected component, I. R. C. This equation is:

$$IRC = \frac{0.85 W (CR_{FW} + 5R_{CW})}{A (1-R)}$$

where W = side window area

R_{FW} = average reflection factor for planes below the midheight of the window excluding the window wall

R_{CW} = average reflectances of room surfaces above the R_{FW} limit, disregarding the window wall

C & 5 are constants depending upon the brightness distribution of the sky and the reflectance of the ground entering the room from above and below the horizontal dividing line respectively.

²R. G. Hopkinson; Architectural Physics, Lighting, London, Her Majesty's Stationery Office, 1963, p. 81.

³Ibid., p. 81.

Values of "C" are tabulated in Hopkinson's book⁴. Henderson and Marsden⁵ postulated that "C" is equal to 40, while Hopkinson determined "C" as being equal to $40 - \frac{D}{2}$ where "D" in degrees is the angle of obstruction.

R = average reflectance of all the room surfaces
including the window wall.

Monograms have been devised according to the above equation, and are known as the B. R. S. monograms⁶.

Paying attention to the above equation, the author wanted to know whether one can increase the amount of internally reflected component beyond the determined range of the equation and what factors have influenced this. A model at 1/100 scale for a room was constructed with a side window located in the middle of its long wall and having initially an area equal to 20 percent of its floor. The internal dimensions of the room were 7.00 meters in width and 14.00 meters in length, with a ceiling of 4.00 meters in height (see figures 1_a and 1_b). The light was controlled so that the upper half of the window received light from the ground and the lower half of the window received light from the sky. The artificial ground had a reflectance of 70 percent. The reflectance of the room boundaries were first designed to be 65 percent.

⁴ Ibid., p. 78.

⁵ S. T. Henderson and A. M. Marsden (editors): Lamps and Lighting, Crane, Russake, and Co., Inc., New York, Second ed., 1972, p.433.

⁶ R. G. Hopkinson: Architectural Physics, Lighting, London, 1963, p. 83.

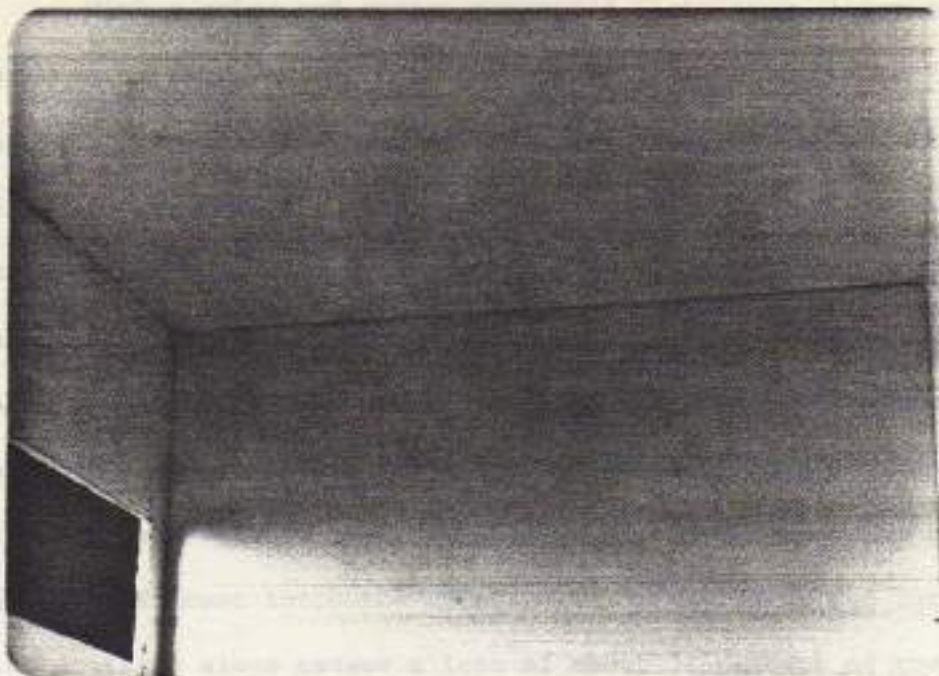

Figure 1_a Interior view of the room (model).

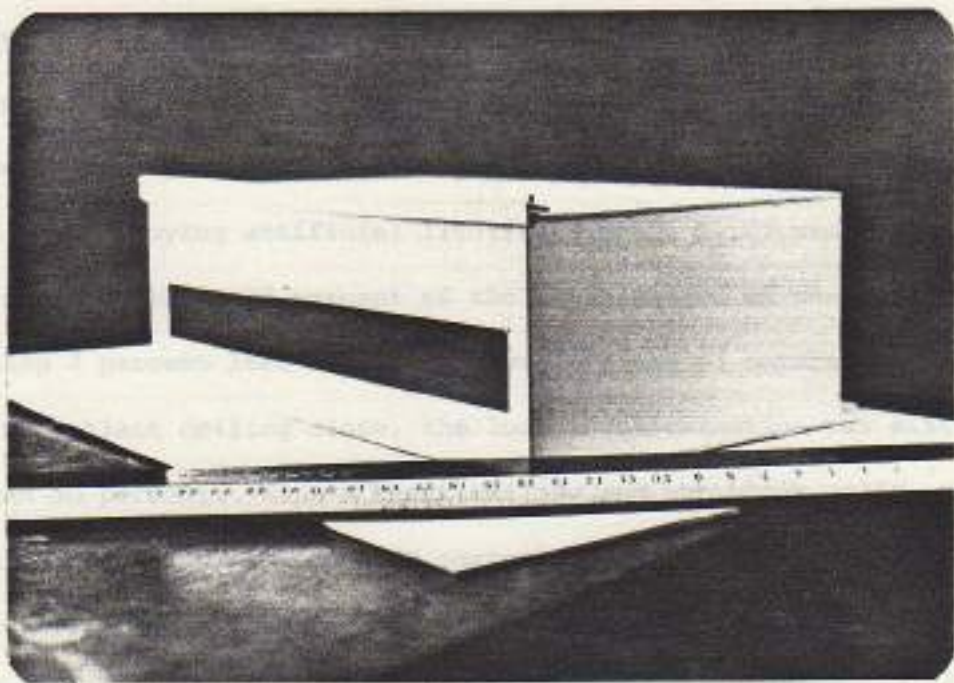

Figure 1_b External view of the model showing the position and size of the window.

With a color and cosine corrected photometer, illumination was measured as received at the reference point located at the foot of the rear wall opposite to the window and along its axis. In the next step, the reflectivity of the interior was removed by covering the surfaces with black color. The I. R. C. is therefore the difference between the two readings measured for each. After the application of the black color over the total interior surfaces, when employing natural light, the reference point lost about 89 percent of the illumination it was receiving (see Table 1). This means that the I. R. C. has a significant influence upon the illumination in the interior. A black ceiling alone causes a loss of about 71 percent of the illumination received at the reference point. The surface areas of the two sides of the room combined equal the surface area of the back wall. The back wall, if black, causes a loss of 52 percent in the illumination of the reference point. The two black sides of the room reduce the illumination by 33 percent and not 52 percent as is expected.

Employing artificial lighting, the I. R. C. was found to contribute to about 87 percent of the illumination of the reference point being 2 percent less than that caused by use of natural lighting. With a black ceiling alone, the loss in illumination was slightly less than 50 percent. With a black ceiling and two black walls, the loss in illumination was about 55 percent. With a black ceiling and a black rear wall, the drop in illumination was 81 percent. Figures 2 through 6 show the results of experiments which attempted to create different probabilities by either splitting the walls by color horizontally, or by positioning the equivalent area of one side of the room (that is; 7.00 by 4.00 meters), at different locations of the

Experiment Number	Description	Io ft-c. *	In ft-c.	% Loss due to N
1	Floor black only	500	155	69.00
2	Black ceiling only	500	145	71.00
3	One side 7.0 x 4.0 Meters, black	525	400	23.81
4	Two sides 7.0 x 4.0 Meters, black	525	350	33.33
5	Back wall 14.0 x 4.0 Meters, black	525	250	52.38
6	Window wall black	565	385	31.86
7	Floor 14.0 x 7.00 Meters, black	565	185	67.26
8	Ceiling and back wall black	575	125	78.26
9	Ceiling and one side black	610	147	75.90
10	Ceiling and two sides black	610	135	77.87
11	Ceiling and floor black	650	103	84.15
12	Floor and one side black	660	130	80.30
13	Floor and two sides black	685	140	97.56
14	Two sides black	685	475	30.66
15	Back wall and one side black	750	300	60.00
16	Back wall and two sides black	745	280	62.42
17	Back wall and window wall black	725	250	65.52
18	Floor and window wall black	750	85	89.10
19	All surfaces black	780	85	89.10
20	All surfaces black except back wall white	830	125	84.94

* Source of illumination - Natural

Io = Initial Illuminance (ft-c.)

In = Illuminance after application of light absorptive surfaces

TABLE 1

Continued.

Continued.

TABLE 1

Experiment Number	Description	I_0 ft-c.	I_N ft-c.	% Loss due to N
21	All surfaces black except ceiling white	800	125	84.38
22	All surfaces black except window wall white	860	83	90.35
23	All surfaces black except two sides	825	80	90.30
24	All surfaces black except floor white	675	75	88.89

Influence of the reflectivity of the room boundaries upon its illumination.

	Ceiling, back wall, and two sides black	25	14.1	42.94
21	Ceiling and back wall black	45	16	64.44
22	Ceiling, back wall, and one side black	46	15	67.39
23	Ceiling, back wall, two sides, and floor black	85	11.5	86.53
24	All surfaces black	85	11	87.06
25	All surfaces black except one side white	85	11	87.06
26	All surfaces black except two sides white	85	11.5	86.53
27	Ceiling, back wall, and window wall black	85	11.5	86.53

I_0 = Initial illumination (ft-c.) * light source artificial

I_N = Illuminance after the application of the light absorbing surfaces listed.

TABLE 2 Influence of the reflectivity of the room boundaries upon its illumination.

Continued.

Experiment Number	Descriptions	I_0 ft-c*	I_N ft-c	% Loss due to N
1	All room surfaces white	85	85	0
2	One side 1.0 x 4.0 Meters black	85	70	17.65
3	Two sides 7.0 x 4.0 Meters black	85	60	29.41
4	Back wall 16.0 x 4.0 Meters black	85	23	72.94
5	Back wall and one side black	85	21	72.29
6	Back wall and two sides black	85	18	78.82
7	Black ceiling 14.0 x 7.0 Meters	85	44	48.24
8	Ceiling and one side black	85	41	51.76
9	Ceiling and two sides black	85	38	55.29
10	Ceiling, back wall, and two sides black	85	14.5	82.94
11	Ceiling and back wall black	85	16	81.18
12	Ceiling, back wall, and one side black	85	15	82.35
13	Ceiling, back wall, two sides, and floor black	85	13.5	84.12
14	All surfaces black	85	11	87.06
15	All surfaces black except one side white	85	11	87.06
16	All surfaces black except two sides white	85	11.5	86.47
17	Ceiling, back wall, and window wall black	85	12.5	85.29

I_0 = Initial Illuminance (ft-c) * Light source Artificial

I_N = Illuminance after the application of the light absorptive surfaces (ft-c)

TABLE 2 Influence of the reflectivity of the room boundaries upon its illumination.

Continued.

Continued, TABLE 2

Experiment Number	Description	I_0 ft-c.	I_N ft-c.	% Loss due to N
18	Ceiling and window wall black	85	33	61.18
19	Window wall black only	85	65	23.53
20	Back wall and window wall black	85	21	75.29
21	Back wall, floor, window wall black	85	17	80.00
22	Floor and window wall black	85	50	41.18
23	Black floor only	85	51	40.00
24	Floor and one side black	85	50	41.18
25	Floor and two sides black	85	47	44.71
26	Floor and back wall black	85	18	78.82
27	Floor, two sides, and window wall black	85	42	50.59
28	Floor, one side, and window wall black	85	46	45.88
29	Floor and ceiling black	85	40	52.94
30	Floor, ceiling, and one side black	85	38	55.29
31	Floor, ceiling, and two sides black	85	36	57.65
32	All surfaces black except back wall white.	85	30	64.71
33	All surfaces black except floor white.	85	11	87.06
34	Window wall and one side black	85	58	31.76
35	Window wall and two sides black	85	50	41.18

Influence of the reflectivity of the room boundaries upon its illumination.

Continued.

Experiment Number	Description	I_0 ft-c.	I_N ft-c.	% Loss due to N
36	Window wall, ceiling, and floor black	85	35	58.82
37	Window wall, ceiling, and two sides black	85	31	63.53
38	Window wall, ceiling, and one side black	85	32.5	61.76

Influence of the reflectivity of the room boundaries upon its illumination.

Light source: Artificial.

7	One side 7.0 x 4.0 meters black on ceiling. Long axis of short axis.	41	22	47.63
8	One side 7.0 x 4.0 meters black on one side of the ceiling. Long axis of short axis.	41	33	51.43
9	One side 7.0 x 4.0 meters black in the middle of the floor. Long axis of short axis.	41	29	50.75
10	One side 7.0 x 4.0 meters black on one side of the floor.	41	34	49.05

I_0 = Initial illumination. * Source of light - artificial

I_N = Illuminance after the application of the light absorptive surface.

Influence of the disposition of a black side of a room in different longitudes upon the illumination of a room.

Experiment Number	Descriptions	I_0 ft-c*	I_N ft-c	% Loss due to N
1	All surfaces white	42	42	0
2	One side 7.0 x 4.0 Meters black on center of back wall	42	24	42.86
3	One side 7.0 x 4.0 Meters black on one side of back wall	42	29.50	29.76
4	One side black only	42	34	19.05
5	One side 7.0 x 4.0 Meters black in the middle of the ceiling. Long axis on long axis.	42	23	45.24
6	One side 7.0 x 4.0 Meters black in the middle of the ceiling. Long axis on short axis.	42	22	47.62
7	One side 7.0 x 4.0 Meters black on one side of the ceiling	42	33	21.43
8	One side 7.0 x 4.0 Meters black in the middle of the floor. Long axis on short axis	42	29	30.95
9	One side 7.0 x 4.0 Meters black on one side of the floor	42	34	19.05

10

TABLE 3

 I_0 = Initial illuminance

* Source of light - Artificial

 I_N = Illuminance after the application of the light absorptive surfaces.

Influence of the disposition of a black side of a room in different locations upon the illumination of a room.

Experiment Number	Descriptions	I_0 ft-c*	I_N ft-c	% Loss due to N
1	Back wall 14.0 x 4.0 Meters black	42	19	54.76
2	Back wall black in the center of the ceiling	42	19	54.76
3	Back wall black on the rear part of the ceiling	42	19	54.76
4	Back wall black on the front portion of the ceiling	42	23	45.24
5	Back wall black on the front portion of the floor	42	22	47.62

I_0 = Initial illuminance

I_N = Illuminance after the application of the light absorptive surfaces

* - Light Source - Artificial

TABLE 4 Influence of the disposition of a black back wall of a room in different locations upon its illumination.

Experiment Number	Descriptions	I_0 ft-c*	I_N ft-c	% Loss due to N
1	Front wall 14.0 x 4.0 Meters black excluding the window	42	27.5	34.52
2	Front wall on back wall	42	27	35.71
3	Front wall on front section of ceiling	42	26	38.10
4	Front wall on the rear portion of the ceiling	42	25	40.48

* Light source - Artificial

I_0 = Initial illuminance

I_N = Illuminance after the application of the light absorptive surfaces.

TABLE 5. Influence of the disposition of a black front wall (excluding the window) on different locations upon the illumination of the room.

11	Lower half of wall containing window, black	55	47	14.55
12	Upper and lower half of window wall, black	55	34	38.18
13	Black floor only	55	25	54.55
14	All interior surfaces white	55	55	0

I_0 = Initial illuminance

* Light source - Artificial

I_N = Illuminance after the application of light absorptive material

TABLE 6. Influence of the disposition of the wall color upon the illumination of the room.

Experiment Number	Descriptions	I_0 ft-c*	I_N ft-c	% Loss due to N
1	All lower half of the room under its center black	55	17	69.09
2	All lower half of the room black except one side	55	17	69.09
3	All lower half of the room black except two sides	55	17	69.09
4	All lower half of the room black except two sides and window wall	55	18	67.27
5	Lower half of back wall black only	55	35.5	35.45
6	Lower half of one side black	55	51	7.27
7	Lower halves of two sides black	55	46	16.36
8	Lower halves of two sides, back wall, and window wall, black	55	28.5	48.18
9	Lower halves of one side, back wall, and window wall, black	55	30	45.45
10	Lower halves of back wall and window wall black	55	25.5	53.64
11	Lower half of wall containing window, black	55	47	14.55
12	Floor and lower half of window wall, black	55	24	56.36
13	Black floor only	55	25	54.55
14	All interior surfaces white	55	55	0

I_0 = Initial illuminance

* Light source - Artificial

I_N = Illuminance after the application of light absorptive material.

TABLE 6 Influence of the division of the wall color upon the illumination of the room.

interior surfaces. However, the results showed that the combination of the back wall and the ceiling has the major contribution upon the illumination in the interior.

To further check this phenomenon, a new experiment was conducted in completely dark surroundings using a free standing wall containing a window. Then an artificial sky was constructed on the side of the external wall so that no light could illuminate the surroundings unless it passed through the window. The direction of some of the light was controlled to achieve ground reflection to the upper half of the window (split-flux theory). With the aid of the photometer and the free movement of the room boundaries, many room shapes could be constructed using different heights and inclinations. After extensive trials and measurements, it was discovered that side walls are effective only when they are placed approximately close to the window opening. In any other setting, their contribution to the reflected component is local and at only a very short distance from the wall. The ceiling can have significant effect if the illuminated area of its surface exceeds 25 percent. The rear wall, on the other hand, played the major role in the I. R. C. Optimum results were obtained when both ceiling and rear wall was tilted towards the plane of the window wall, the far edge of the ceiling tilted downwards and the upper edge of the rear wall was tilted to the interior of the room. This proves that the surfaces of the room act as reflectors of efficiency, depending upon their reflection factor, and thus follow the law of reflection. Thus, considering a room as having a sphere of average reflection factor split into two parts cannot be taken for granted, though it is useful in determining the I. R. C. of conventional rooms and

checking for an overall estimation; nevertheless, it constitutes restrictions to the designer and does not encourage innovations in the design with natural light.

Thus, our results do not support Hopkinson's remark that the side walls near the window have a significant contribution to the I. R. C., and the ceiling and back walls are only given high reflectance for subjective reasons and appearance. Hopkinson's lack of clarity in his discussion is evident to the reader as he states in the same paragraph"

"...in addition, a light coloured ceiling and a light coloured back wall does enhance the internally reflected light by raising the average reflectance of the whole room so that it has quantitative significance..."⁷

It was observed that the ceiling and the back wall have more quantitative significance than the side walls even if the window is placed near a side wall. This can not only be argued experimentally but also theoretically. The window receives its light from three paths: the sky, the horizon (or external obstructions), and the ground. Since light travels in straight lines and has a very short wave length it does not bend around a partition or bend after penetrating an opening. Thus the surfaces opposite the window receive the major quantity of light. Each of these surfaces reflect light according to the amount of light falling upon them, depending on their reflective coefficients. If the light entering a window is allowed to spread over

⁷R. G. Hopkinson: The Lighting of Buildings, Faber and Faber, London, 1969, p. 89.

a wide area, such as in the case of side walls, the intensity of light in a point near a window will be much greater than that falling at some distance along the side wall. At the same time, the area of the window as seen from any point along this side wall, is less than that seen from a point at the back wall. It could be argued that the back wall receives no light in the presence of an external obstruction and thus, will receive less light than the side walls. This is true for a small part of the side wall, but the major area of it receives neither direct skylight, nor sufficient amount of reflected light from that external surface; hence, the total amount of reflections received from the whole area of the wall will be inferior to the quantity received from the back wall. The same thing can be said about the ceiling which receives light directly from the ground. In many cases the ground receives light from direct sunlight and reflects about 15 percent of it to the ceiling. On the other hand, if the ceiling is made to receive direct sunlight by letting the head of the window reach the ceiling, or by tilting the remote third of the ceiling downward, the efficiency of the ceiling will not only be increased but the resulting brightness will also balance the deprived parts of the enclosure. It should be observed that raising the window head to the ceiling, in addition to being of use to the ceiling, will raise the sky component and will enhance the angle of incidence upon the reading plane. However, this must be carefully manipulated in such a manner as not to allow the reader to be placed opposite the section of sky seen from the window. This will be dealt with in the discussion of the problem of disability glare.

According to the author's experiments and the above discussion, two examples of reading rooms with side windows exposed to different lighting conditions are presented. These examples, as shown in Figures 2, 3, and 4 emphasize the method rather than the solution and it is left open to future innovations as long as these principles are observed.

Before discussing the proposed simplified methods of calculating the interior daylighting in a room, elaboration is needed as to the influence of the window reveal on the quantity of light received in a room. The shapes of the window reveals under discussion are either straight or beveled. The internal size of the window is maintained constant while comparing each case. The reveal is beveled either to the interior or to the exterior at 45 degrees and the straight reveal extends 12 centimeters beyond the external wall to form a frame around the opening, otherwise the thickness of the reveal is 0.29 meters.

As the experiment was conducted, the window height was maintained constant at 1.30 meters, while the position of the window (which is located in one wall of the room) and its width are made variable. In the following chapter, the experiment and the findings will be discussed in detail. What will be explained here is how the quantity of light and its distribution inside the room are influenced greatly by the reveal shape. Figures 5, 6, 7, and 8 show contours of relative distribution of illuminances on table level recorded by a color and cosine corrected photometer when the sky was totally overcast.

Since the quantity of light at a reference point inside the room, excluding internal reflections, varies according to the area of the sec-

For quick estimation of sky component (SC) in the design stage decide height's projection by twice the radius as follows: a) $SC = \frac{1}{145} \times 45$
 % of $\frac{1}{2}$ $SC = \frac{21.5 \times 45}{145} = 6.51\%$
 from Protractor 1.02%

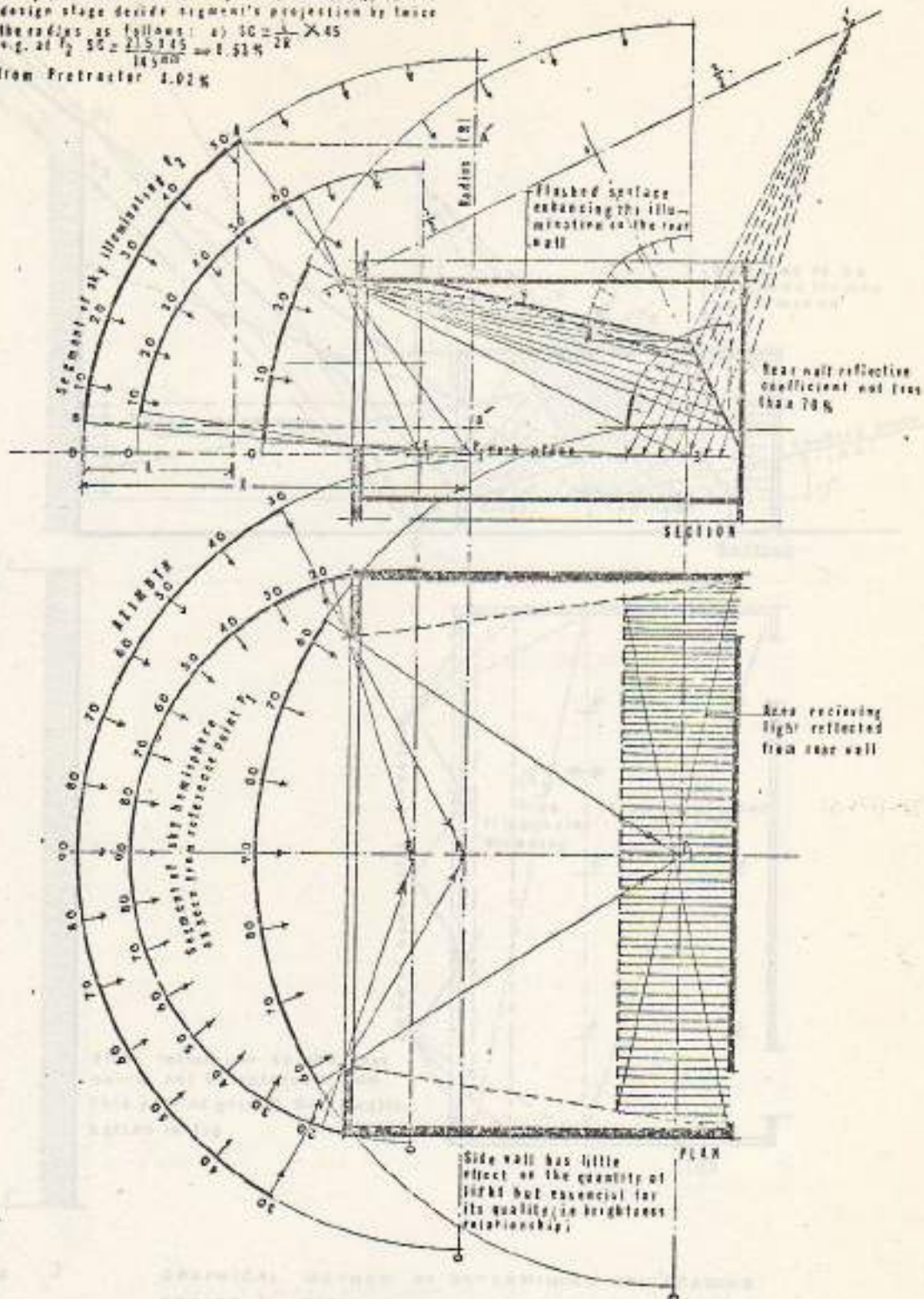

Fig 2 GEOMETRICAL METHOD of DESIGNING ROOM SHAPE for READING ROOMS with SIDE WINDOWS and NO EXTERNALLY REFLECTED COMPONENT ETC

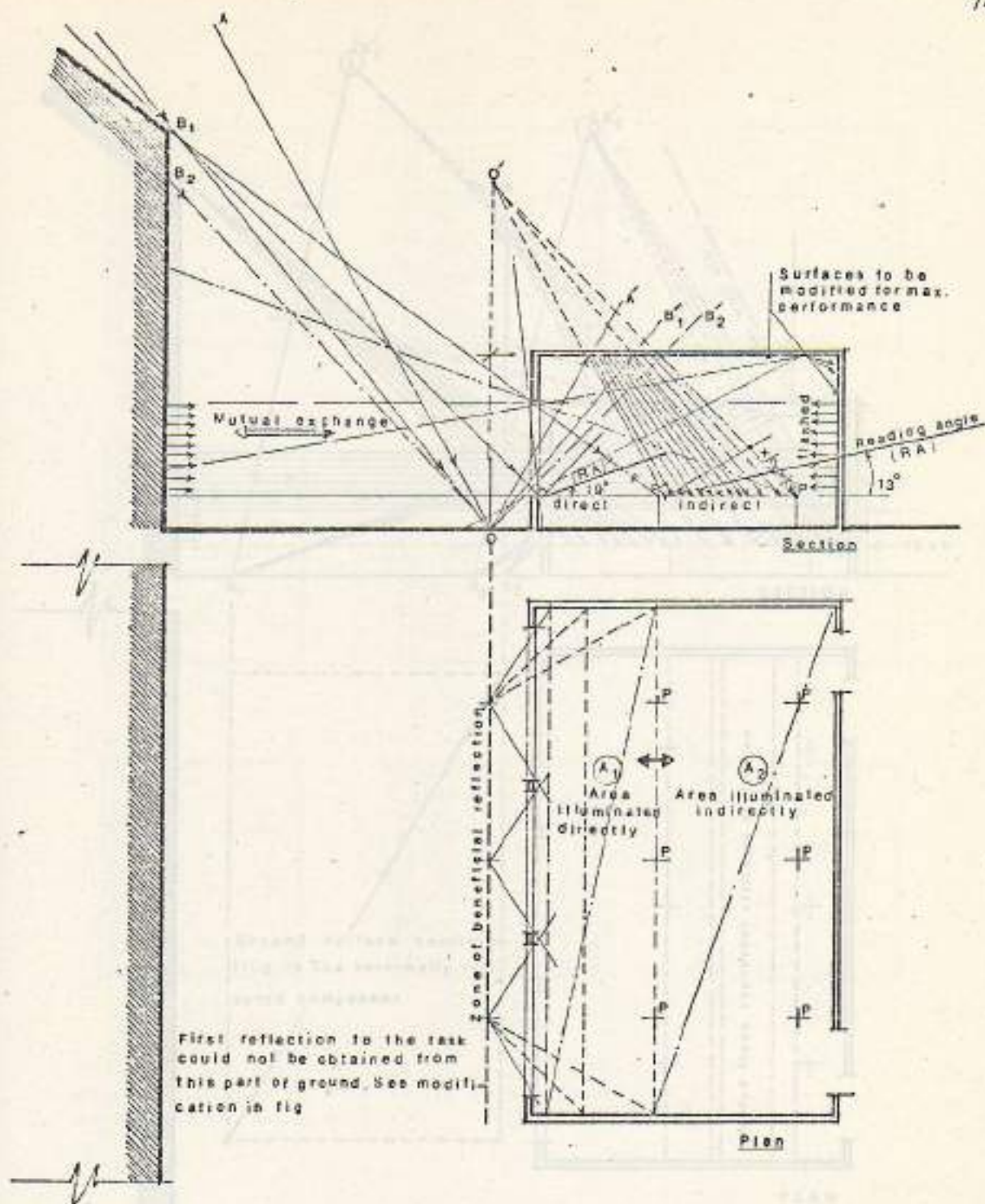
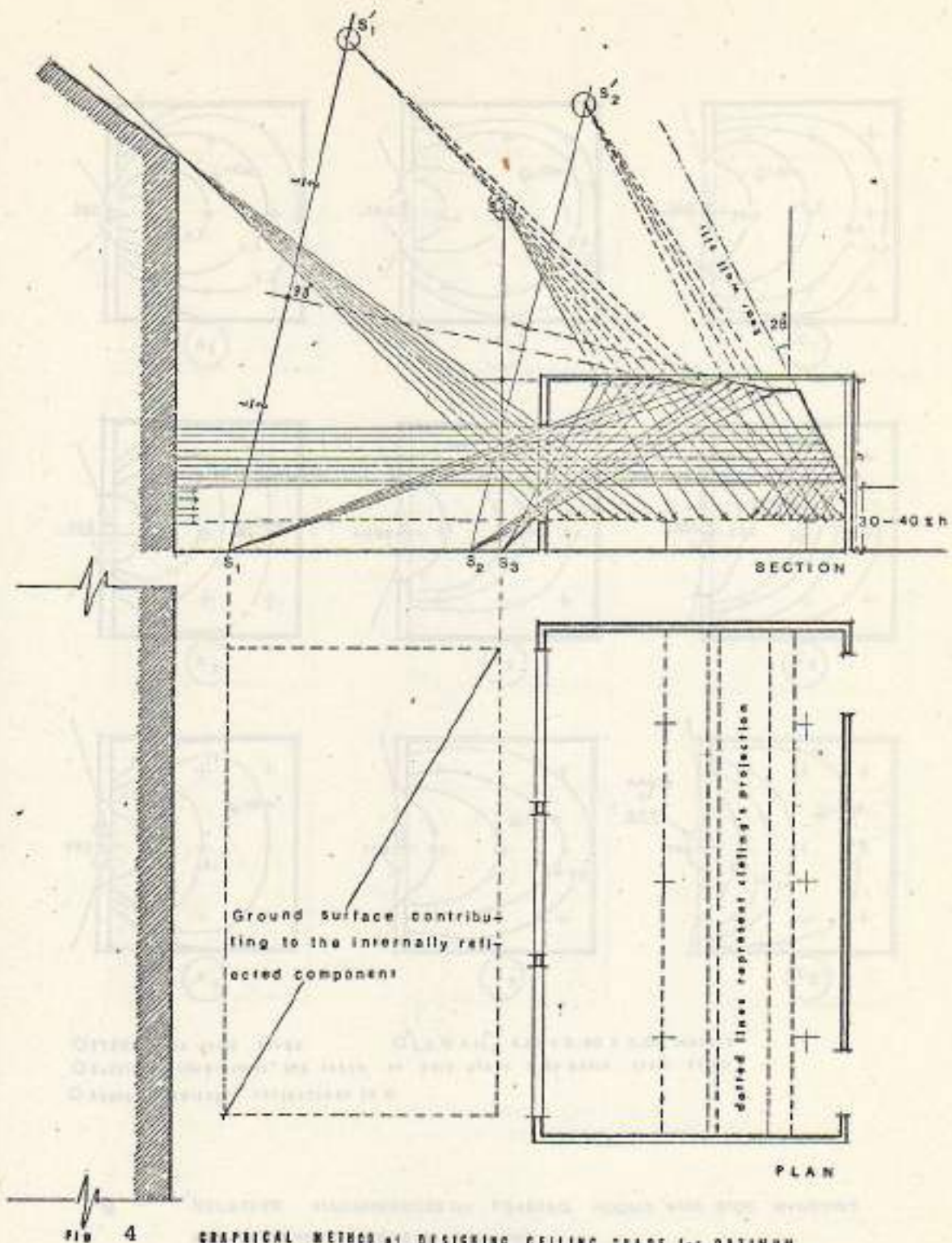
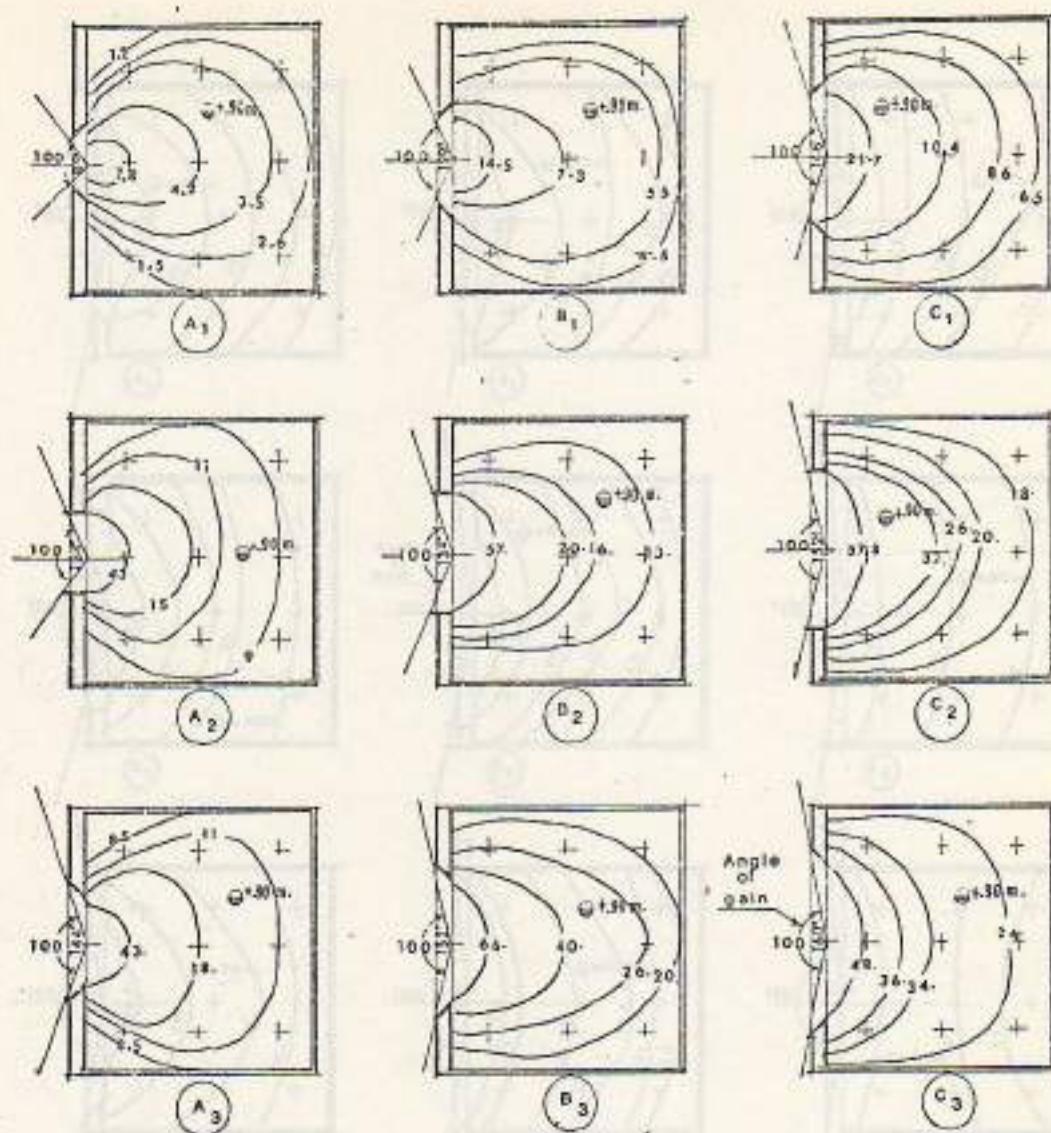

Fig 3

GRAPHICAL METHOD OF DETERMINING THE 'READING ANGLES' FOR RECTANGULAR ROOMS WITH SIDE WINDOWS AND EXTERNAL OBSTRUCTION



GRAPHICAL METHOD of DESIGNING CEILING SHAPE for OPTIMUM FLASHING in RECTANGULAR READING ROOMS with SIDE WINDOWS and EXTERNAL OBSTRUCTION



- PLANS into scale 1:100 ○ L x W x H = 4.00 x 3.50 x 3.00 meters
 ○ Relative illuminances are taken at work plane 0.90 meter from floor
 ○ Average surface reflectance 20 %

Fig 5 RELATIVE ILLUMINANCES for READING ROOMS with SIDE WINDOWS and DIFFERENT REVEAL SHAPES

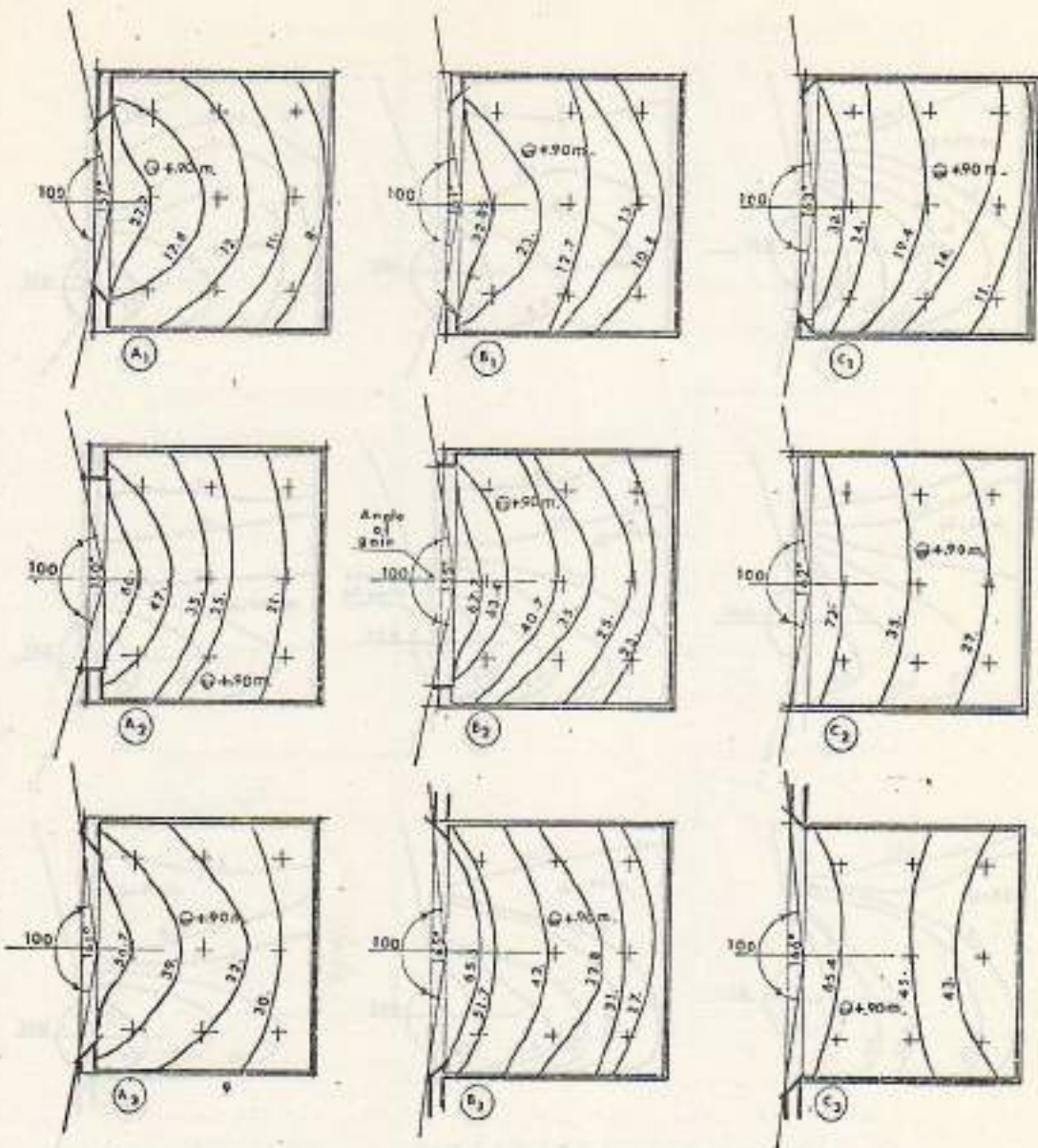

- PLANS into scale 1:100
- L x W x H = 4.00 x 3.50 x 3.00 meters
- Average surfaces reflections 90%
- reflect are for reading level

Fig 6 RELATIVE ILLUMINANCES for READING ROOMS with SIDE WINDOWS and DIFFERENT REVEAL SHAPES

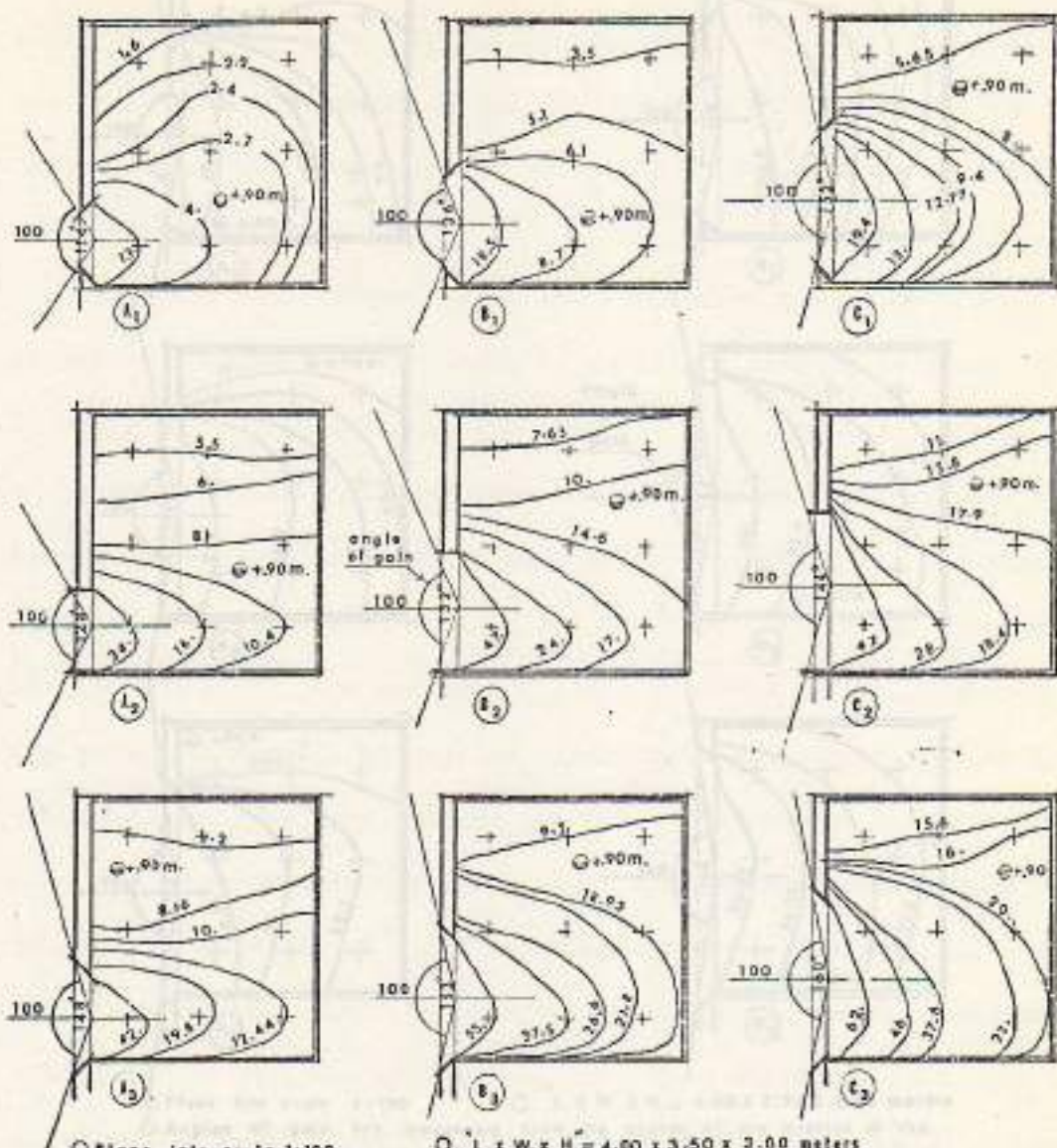

- Plans into scale 1:100. ○ L x W x H = 4.00 x 3.50 x 3.00 meters
 ○ Angles of gaze are measured from the center of the interior of the windows' openings.
 ○ Readings of the relative illuminance are taken on a horizontal plane 0.90 meter from floor level.
 ○ Heights of windows are maintained constant = 1.30 m.
 ○ Orientation is due NE & overcast sky ○ Average wall reflections 70%

FIG 7 RELATIVE ILLUMINANCES FOR READING ROOMS WITH SIDE WINDOWS AND DIFFERENT REVEAL SHAPES

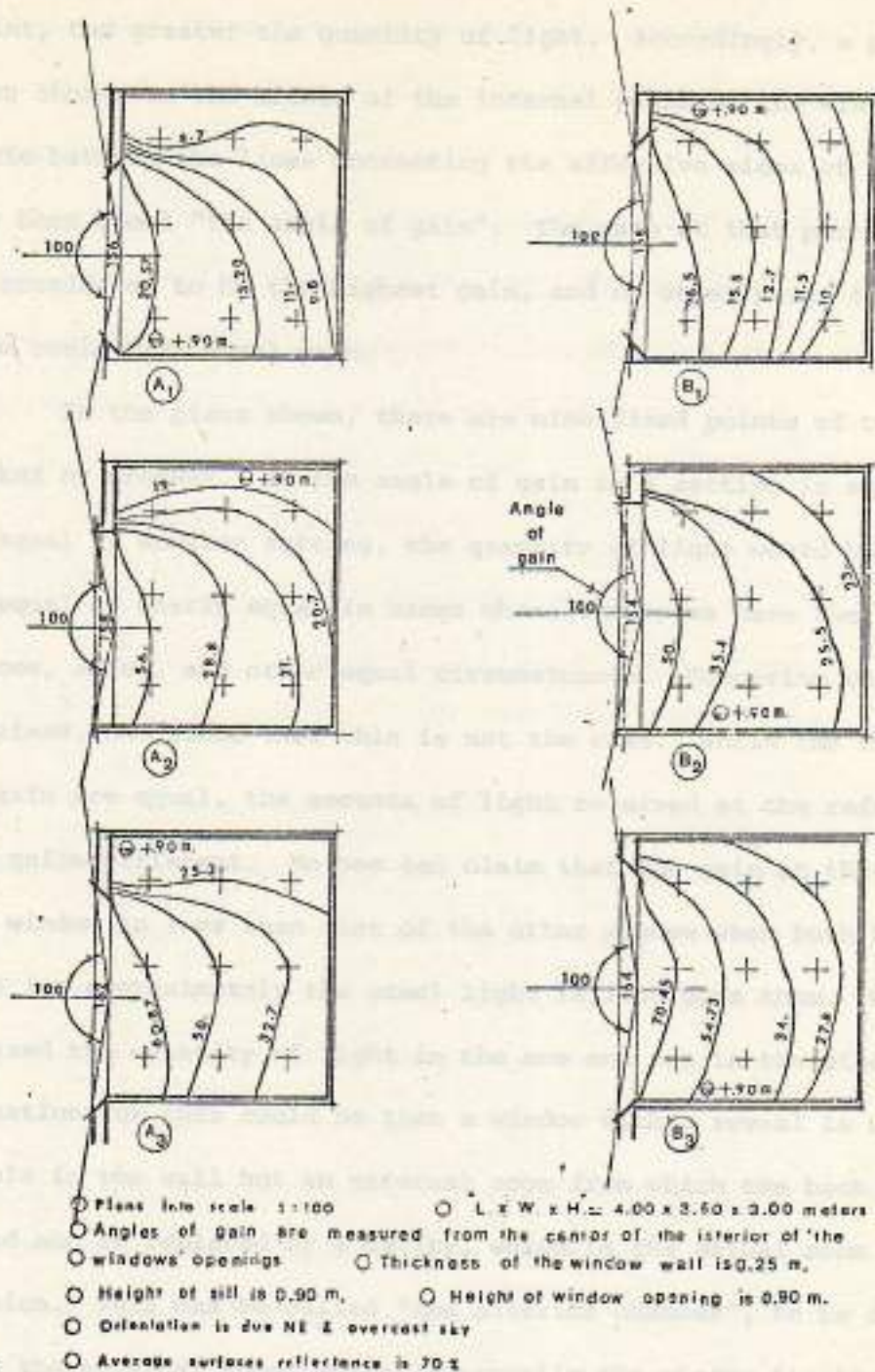

Fig 8 RELATIVE ILLUMINANCES for SEATING ROOMS with SIDE WINDOWS and DIFFERENT REVEAL SHAPES

tion of sky as seen from the window, it follows that the greater the magnitude of the elevation and azimuthal angle as measured from the point, the greater the quantity of light. Accordingly, a point has been chosen on the middle of the internal plane of the window, and the angle between the lines connecting the effective sides of the window has been named "the angle of gain". The gain at that particular point is considered to be the highest gain, and no other point inside the room could have equal gain.

In the plans shown, there are nine fixed points of comparison marked by crosses. If the angle of gain in a setting is equal or nearly equal to another setting, the quantity of light would be expected to be equal or nearly equal in cases where the rooms have the same reflectances, sizes, and other equal circumstances. Comparing the results obtained, one finds that this is not the case. While the two angles of gain are equal, the amounts of light received at the reference point are quite different. No one can claim that the gain at the center of one window is less than that of the other window when both have the same (or approximately the same) light falling upon them. What has increased the quantity of light in the one and not in the other? One explanation for this could be that a window with a reveal is not merely a hole in the wall but an external room from which the back wall is removed and is replaced by a cavity, which is the actual room in our discussion. This can be called "the anterior chamber", to be distinguished from the external room, which is actually the window itself.

According to the findings, the external room should be designed so that it collects light and introduces it to the cavity behind the anterior chamber.

In the calculations, reference will be made to the influence of the reveal using the term "Reveal Reflection Component", R. R. C., the value of which is dependent upon the type of bevel, surface reflectance, and its area.

In the case of the reveal bevelled to the exterior, all the sides will receive light from the sky, the ground, and the external obstructions, if any. The contribution of the R. R. C. to the total sky factor in the interior will be as follows:¹

$$R.R.C. = 0.19 R_A \cdot p \cdot S.C. \cdot \frac{1}{4}$$

where R_A = reveal surface area

p = reflection coefficient of the reveal

S.C. = sky component

0.19 is a constant obtained from considering that the reveal is exposed to half quadrant of sky and therefore, having a sky factor of 25 percent. In the same sense, the ground reflects 20 percent of the incident light falling upon it to the reveal. The maintenance factor is about 50 percent efficiency, and glass transmission is taken as 85 percent.

In the case of the window having external obstruction, determination is made graphically as to the portion of sky that has been obstructed; this is multiplied by the reflection coefficient of that obstruction, or by 10 percent, if not known. Identical area from the sky is omitted. Thus, the equation will be reduced to:²

$$R.R.C. = 0.19 R_A \cdot p \cdot S.C. - 0.1 E_A \%$$

where E_A - area of external obstruction enclosed in the half quadrant of sky opposite to the window center

In the case of a window with straight reveal without external obstruction, the equation will be:³

$$R.R.C. = 0.33 R_A \cdot p \cdot S.C. \%$$

where 0.33 is a constant obtained from considering the reveal

In the above case, equation number 3, 50 percent is exposed to the sky and 50 percent to the ground, and the maintenance factor is 65 percent, since the reveal is accessible. The transmission of the glass is taken as 85 percent, as previously.

Obstructions, if any, can be treated as before, by subtracting the patch of sky removed from the window by such obstruction, as seen from the average point in the reveal (or middle point), and adding the effect of the obstruction by multiplying its area by its reflectance, or by 10 percent, if not known.

In the case of the reveal bevelled to the interior, the contribution of the reveal will be minimum, since any light falling upon it from the sky will be spread over the whole surface of the reveal. Maximum results are only obtained from the part of the reveal at the level of the window sill. It is safe to conclude that the R. R. C. obtained in such a case, considering other factors, such as the possibility of the lower reveal to reflect light to the ceiling, is 30 percent that of the straight reveal. Hence:⁴

$$R.R.C. = 0.11 R_A \cdot p \cdot S_C^2$$

It is now possible to add the influence of the reveal to the total component reaching the reference point. Since the light reaching the reference point is the sum of the sky component, the externally reflected component, and the internally reflected component, the equation can be written including the effect of the reveal as follows:⁵

$$S_F = S_C + E.R.C. + I.R.C. + R.R.C.$$

where S_F = sky factor

S_C = sky component (will be discussed)

E.R.C. = Externally Reflected Component

I.R.C. = Internally Reflected Component

R.R.C. = Reveal Reflectance Component

This sum is expressed as a percentage of sky factor (SP%). This means that the sky factor (S_F) will be determined according to the time of the day and the season of the year. The E. R. C. is the externally reflected component resulting from light reflected from the ground and from the opposite facades to the window. Its magnitude depends upon the reflectance of the surfaces, the distance between such surfaces and the window, and the condition of the light. The light reflected from the ground is received by the upper half of the window reveal and by the upper ceiling of the room, while light reflected from vertical obstructions, such as building facades opposite the window, illuminates the rear wall and the horizontal reading plane, according to the area of the obstruction as seen and determined graphically from a reference point. It follows that the further the obstruction is, the less the

area will be, and the less its influence is upon the work plane. It should be noted that although we design the lighting for the worst cases, the amount of reflectance will increase on sunny days, especially if such surfaces are facing the south. Nevertheless, this should not be an obstacle, as an increase in the E. R. C. will cause an increase in the internally reflected component, and the ratio will remain the same. In semi-cloudy regions, this will cause light to fluctuate in the interior and become a source of annoyance. This is worse on windy days when the direct sun is blocked out for short intervals. This means that where the location is characterized by such conditions, orienting the window due north, when there is a permanent obstruction facing the window, does not secure a constant level of illumination in the interior. To avoid this problem, the window should be either high enough and positioned horizontally, or should be located away from such obstructions. Such arrangements will cause the ceiling to receive much of its light from the ground and partially from the horizon. This will compensate for the loss of light in the area of the front wall which contains the window as a remarkable increase in the internally reflected component, I. R. C. will be caused by increasing the illuminance of the ceiling and by providing a reflective surface under the window sill.

Thus the E. R. C. is equal to the area of the obstruction as seen from the reference point, which can be determined graphically from a scale drawing, multiplied by its reflectance and then by the sky component falling upon it.

To simplify the method of determining the sky component, the

author has designed a protractor from which one can obtain the value of the $S_c\%$ once the effective azimuthal and elevation angle has been determined. The value of this protractor lies in that it can be used not only for vertical windows, but also for skylights and windows at any inclination as long as they can be seen from the reference point. The approach and the design method will follow. However, it should be noted that there are many graphs and tables which can be used with great accuracy for the calculation of the sky component.

1. One source is the Building Research Station's Daylight Protractors (B. R. S.), which is comprised of five pairs to be used for different window settings⁸. While the B. R. S. based its design upon the illumination coming from a uniform sky to an infinitely long horizontal window with parallel edges placed on a vertical wall, this author's design is based upon the illumination resulting from an element of a non-uniform overcast sky as projected on a horizontal plane. The reason for this is that this study's experiments designed for the overcast sky of the U. S. A. are found to conform to the relative distribution principle adopted by the Commission International de L'Eclairage (C. I. E.) in 1955⁹. The main feature of the C. I. E. relative luminance distribution is that the luminance at a point receiving light from an overcast sky at an altitude angle " θ " above the horizontal is equal to one third of the luminance at the zenith multi-

⁸R. G. Hopkinson, P. Petherbridge, J. Longmore: Daylighting, Heinemann, London 1963, pp. 128-156.

⁹Ibid., p. 43.

plied by $(1 + 2 \sin \theta)$. That is $L_{\theta} = 1/3 L_z (1 + 2 \sin \theta)$ ^{10*} This means that the B. R. S. protractors will give greater values of S_C for vertical windows than those obtained from the C. I. E. relative luminance distribution.

2. There is also a diagram which was devised by P. J. and J. M. Waldram in 1923 and is known as the Waldram diagram¹¹. Their method is similar to ours in principle but it is different in design. While this author's proposed design is based on the solid angle projection on a horizontal plane, the Waldrams constructed a rectangular network with abscissae proportional to the azimuth angle and with ordinates proportional to $(1/2 \sin^2 \theta + 2/3 \sin^3 \theta)$ where θ is the angle of elevation so that S_x is proportional to S_{θ} , and S_y is proportional to $S_{\theta} (\sin \theta \cos \theta + 2 \sin^2 \theta \cos \theta)$ ^{12*}. Tracing the outline of the sky visible from a reference point on the diagram and dividing the area enclosed by the trace by twice the area of the network, will give the sky component at any reference point in the interior. Two Waldram diagrams juxtaposed opposite to each other are necessary to calculate the S_C due to a skylight. Unlike the protractor in this study, the Waldram diagram cannot be used for more than one side of a room at a time. The pro-

^{10*} S. T. Henderson and A. M. Marsden: Lamps and Lighting, Crane, Russak and Co., Inc., New York, 1972, p. 421.

¹¹ P. J. and J. M. Waldram: Window Design and the Measurement and Predetermination of Daylight Illumination, Illumination Engineering Society, London, 1923.

^{12*} S. T. Henderson and A. M. Marsden: Lamps and Lighting, Crane, Russak and Co., Inc., New York, 1972, p. 427.

posed protractor in this study can be used for all sides of the room, including the ceiling, in one operation. Moreover, one need not compute areas as the results are obtained directly from the protractor which will be demonstrated later on in this study.

3. J. W. T. Walsh¹³ has introduced a formula to be used for rectangular windows exposed to a uniform sky. His formula is based on the relation between the width and height of the window and the distance between the plane of the window and the reference point.

The formula used is as follows:

$$\text{Sky Factor} = \frac{50 WH^2}{D (D^2 + H^2)^{3/2}}$$

The disadvantage of this formula is that the sky factor obtained when D is less than W is exaggerated. For example, if W is equal to 6 feet, and H equals 3 feet, the sky factor at a distance of one foot from the window will be 85.987 percent, while in actual settings it is less than half that obtained from the formula. The above formula was utilized to construct diagrams called "Unit-width Daylight Illumination"¹⁴.

4. Pleijel, on the other hand, introduced a system of diagrams for the calculation of both daylight and sun penetration¹⁵ by the stereographic projection of the sky vault. His system is not extensively used because of the preparation needed to obtain results. For instance, one of his diagrams for the horizontal plane consists of a number of dots where each dot represents a 0.1 percent sky factor.

¹³R. G. Hopkinson, P. Petherbridge, J. Longmore: Daylighting, Heinemann, London, 1963, p. 181.

¹⁴Ibid., p. 182.

¹⁵Ibid., p. 183.

To know the sky factor for a reference point in a room, one has to prepare what is called the "screen figure". The screen figure can be prepared in the case of existing buildings by photographing the patches of sky as seen from the reference point by a paraboloidal mirror. The photograph must be transparent and the same size as the diagram to be overlaid. By counting the dots seen through the transparency and dividing them by the total number of dots (which total 1004), the sky factor can be obtained.

For a non-existing building, a "screen figure" must be prepared from drawings. This is done by tracing the windows over a chart called the "screen card" which consists of a circle containing arcs of circles horizontally and vertically (figure 9). The method of tracing the windows over the screen card is the same as that used in the Waldram diagram. The screen card with the trace must then be laid over Pleijel's diagram and the sky factor can be determined.

This study's proposed method contains both the advantages of Pleijel's and Waldram's diagrams, in that it uses the same general principles, but without employing a camera, a screen card, or the need to compute areas or dots. The only disadvantage of this protractor is the cramped scale at low angles of elevation, but this has been solved by increasing the size of the protractor. Also, the protractor has an error of only -0.03 percent sky factor. This is due to confining the sky component numbers to two decimals.

Before describing the protractor's use in determining the sky component at a reference point in the interior, discussion will focus on the method and tools used in the design.

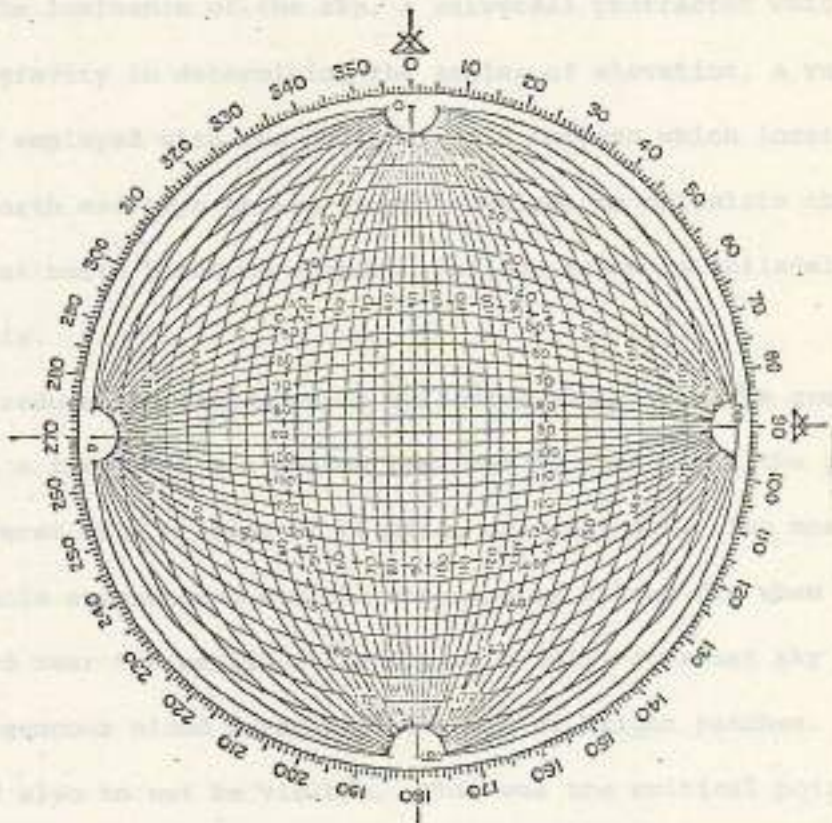

FIG. 9 The screen card used to prepare figures for use with the Pleijel Diagrams.
(after Hopkinson)

The relative humidity was 84 percent. The time of measurement was from 11:30 to 12:30 water-sunlight being low. Giving the rarity of the occasion, the greatest possible number of readings and measurements were taken. These conditions have not been repeated for more than a few weeks in subsequent days.

Comparing the results obtained with that of observations made on 24 July, it was discovered that the conditions of the sky on the

To begin with, it was important to know the conditions of overcast skies in the United States. Is the sky uniform or non-uniform, and what is the degree of deviation from the agreed standards? To answer these questions, tests were conducted for the actual conditions. Tools used included a color and cosine corrected photometer which measured the luminance of the sky, a universal protractor which operates by gravity in determining the angles of elevation, a variable protractor employed with the photometer, a compass which located the magnetic north and maps having isogonic values to calculate the true geographical north based on compass readings taken in Philadelphia, Pennsylvania.

To reduce the influence of reflected light from the ground to a minimum, a flat roof was chosen that was 40 feet above the ground. It was covered with a layer of bitumin, one year old. The most difficult obstacle encountered was the choosing of a long day when the sun was located near the zenith while having a fully overcast sky containing a homogeneous cloud layer without dark or bright patches. The sun needed also to not be visible. This was the critical point of design. Following two and half years of daily observations of summer skies in West Philadelphia, May 6, 1978, these conditions existed. The relative humidity was 86 percent. The time of measurement was from 14:30 to 15:30 eastern daylight saving time. Knowing the rarity of the occasion, the greatest possible number of readings and measurements were taken. These conditions have not been repeated for more than a few seconds in subsequent days.

Comparing the results obtained with that of universally agreed to values, it was discovered that the conditions of the sky of the

United States of America confirm the values adopted by the C. I. E. for relative distribution of overcast sky. What was not expected was that half of the sky's hemisphere, not containing the sun, produced more luminance than the other half containing the sun. A proposed explanation for this is that the former acted as a reflector for the scattered light from the latter, while at the same time, being a diffuser. This indicates that under overcast conditions, the southern facades of buildings receive less illumination than the northern ones, while under clear sky conditions, what happens is the reverse.

Accordingly, the theory of uniform sky was disregarded, and the theory of nonuniform sky adopted by the C. I. E. was employed in the study design. In Figure 10 a comparison between the relative luminance distribution of C. I. E. overcast sky and that of Philadelphia's natural fully overcast sky is shown. Also, the results obtained from the experiment are shown in Table 7.

The next step consists of dividing the sky hemisphere into small elements where the position and areas of these elements can be determined mathematically in terms of θ for elevation angle and α for azimuth angle. The area of each element can be calculated in terms of $d\theta$ and $d\alpha$ by integration, then by employing the C. I. E. equation of relative luminance distribution for overcast sky. One can thus reach a formula to determine the illuminance at the center of the sky hemisphere. If the chosen elements are projected to be a total of 648 elements on a horizontal circle of a radius equal to that of the sky hemisphere, then it would be possible to produce a protractor that enables the calculation of the sky component at any

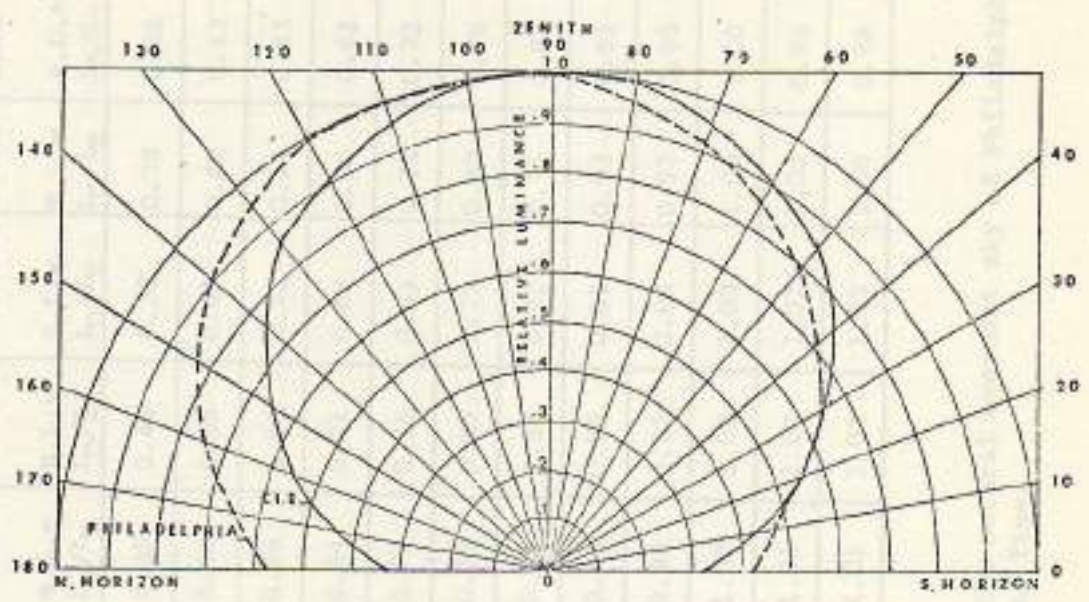

C.I.E. $I_{\theta} = I_z \left(\frac{1 + 2 \sin \theta}{3} \right)$ where I_{θ} & I_z = luminance at θ & zenith
 Philadelphia total overcast sky ;
 Specifications:
 PHILA- May 6, 1978 R.H. 86% Precipitation 20%
 No individual clouds, dark or bright patches visible
 Time of measurements 14.30 - 15.30 Philadelphia Time
 Latitude 40 North, longitude 76
 Local North is corrected by the isogonic values of 1875 to
 (11 W) (U.S. Department of Commerce)
 Ground reflection from 1 year old bitumin covered flat roof

Fig 10 Comparison between relative luminance distribution of CIE overcast sky and that of Philadelphia natural fully overcast sky

Angle of Elevation	Ex. I R.L.*	Ex. II $R.L. = \frac{I_0}{I_z}$	Ex. III $R.L. = \frac{L_0}{L_z}$	Ex. IV $R.L. = \frac{L_0}{L_z}$	Ex. V $R.L. = \frac{I_0}{I_z}$	Ex. VI $R.L. = \frac{I_0}{I_z}$	Ex. VII $R.L. = \frac{I_0}{I_z}$	Ex. VIII $R.L. = \frac{I_0}{I_z}$	Ex. IX $R.L. = \frac{I_0}{I_z}$	Ex. X $R.L. = \frac{I_0}{I_z}$	Ex. XI $R.L. = \frac{I_0}{I_z}$	Ex. XII $R.L. = \frac{I_0}{I_z}$	Aver.
0	0.43	0.43	0.45	0.46	0.41	0.45	0.48	0.38	0.38	0.36	0.34	0.37	.42
10	0.51	0.48	0.55	0.46	0.49	0.48	0.55	0.40	0.40	0.43	0.44	0.43	.47
20	0.58	0.57	0.62	0.53	0.59	0.56	0.64	0.54	0.54	0.53	0.56	0.48	.55
30	0.67	0.64	0.71	0.63	0.67	0.64	0.71	0.63	0.66	0.62	0.71	0.62	.64
40	0.73	0.71	0.79	0.68	0.73	0.73	0.76	0.63	0.70	0.72	0.73	0.63	.71
50	0.82	0.80	0.83	0.78	0.80	0.76	0.83	0.72	0.80	0.79	0.83	0.72	.79
60	0.88	0.87	0.90	0.83	0.88	0.85	0.95	0.82	0.91	0.87	0.80	0.80	.86
70	0.94	0.93	0.95	0.90	0.93	0.93	0.95	0.89	0.93	0.91	0.95	0.87	.92
80	0.98	0.96	0.98	0.95	0.98	0.98	0.95	0.89	0.97	0.95	0.98	0.91	.94
90	1.00	1.00	1.00	1.00	1.00	1.00	1.00	1.00	1.00	1.00	1.00	1.00	1.00
100	1.04	1.00	1.00	1.02	1.00	1.01	1.02	1.02	1.02	0.96	1.00	1.00	1.01
110	1.04	1.00	1.00	1.03	1.00	1.01	1.02	1.05	1.00	0.98	1.00	1.00	1.01

* R.L. = Relative Luminance

TABLE 7 Relative Luminance distribution of the natural overcast sky of Philadelphia, Pennsylvania, May 6, 1978, Time 14:30 - 15:30 Local Time.

Continued. TABLE 7

Angle of Eleva- tion	Ex. I R.L.= L/L	Ex. II R.L.= L/L	Ex. III R.L.= L/L	Ex. IV R.L.= L/L	Ex. V R.L.= L/L	Ex. VI R.L.= L/L	Ex. VII R.L.= L/L	Ex. VIII R.L.= L/L	Ex. IX R.L.= L/L	Ex. X R.L.= L/L	Ex. XI R.L.= L/L	Ex. XII R.L.= L/L	Aver.
120	1.02	0.98	0.98	1.00	0.98	0.98	1.02	1.05	0.97	0.94	0.95	1.00	.99
130	0.98	0.95	0.93	0.98	0.93	0.93	0.98	0.99	0.92	0.89	0.90	1.00	.95
140	0.94	0.89	0.86	0.95	0.85	0.87	0.95	0.99	0.97	0.81	0.83	0.93	.90
150	0.88	0.80	0.81	0.87	0.80	0.85	0.91	0.92	0.75	0.75	0.78	0.87	.83
160	0.80	0.71	0.74	0.80	0.71	0.70	0.87	0.86	0.66	0.64	0.68	0.78	.75
170	0.73	0.63	0.64	0.70	0.63	0.62	0.72	0.79	0.57	0.57	0.59	0.67	.66
180	0.63	0.55	0.57	0.63	0.56	0.53	0.64	0.73	0.49	0.47	0.51	0.59	.58

Relative luminance distribution of the natural overcast sky of Philadelphia, Pennsylvania, May 6, 1978,
Time 14:30 - 15:30, Local time.

point whether in the interior or in the exterior of a building.

Also, since the protractor represents the whole sky luminance as projected onto a horizontal disc and the reference point is the center of this disc, then any patch of sky as seen from the reference point can be traced on the protractor according to its actual position in the sky. The protractor can also be used to determine the externally reflected component when the results obtained from the protractor are multiplied by the reflectance of that part of obstruction as seen from the reference point. Another feature of the protractor is that it can be used with the sun's path diagrams, which will be discussed later when dealing with sunlight. This enables the designer not only to determine the sky component and the externally reflected component, but also to know the expected duration of the sun or overcast sky for each hour, according to the different seasons and months of the year. For this purpose the scale of the protractor was made equal to the sun's path diagrams, that is, the radius of the sky hemisphere is kept constant in both cases.

In Figure 11 the elevation of the sky is represented by a half circle of radius "r" with a plan having a circle of the same radius. If a strip is cut in any part of the elevation, its proportion will be a ring in plan. If such a ring is divided into small elements, the illumination resulting from each element and its effect at the center can be calculated using the inverse square and the cosine laws. In other words, the product of the intensity and the inverse square of the distance (which in this case, is the radius) will give the contribution of this element to the illumination at the center of

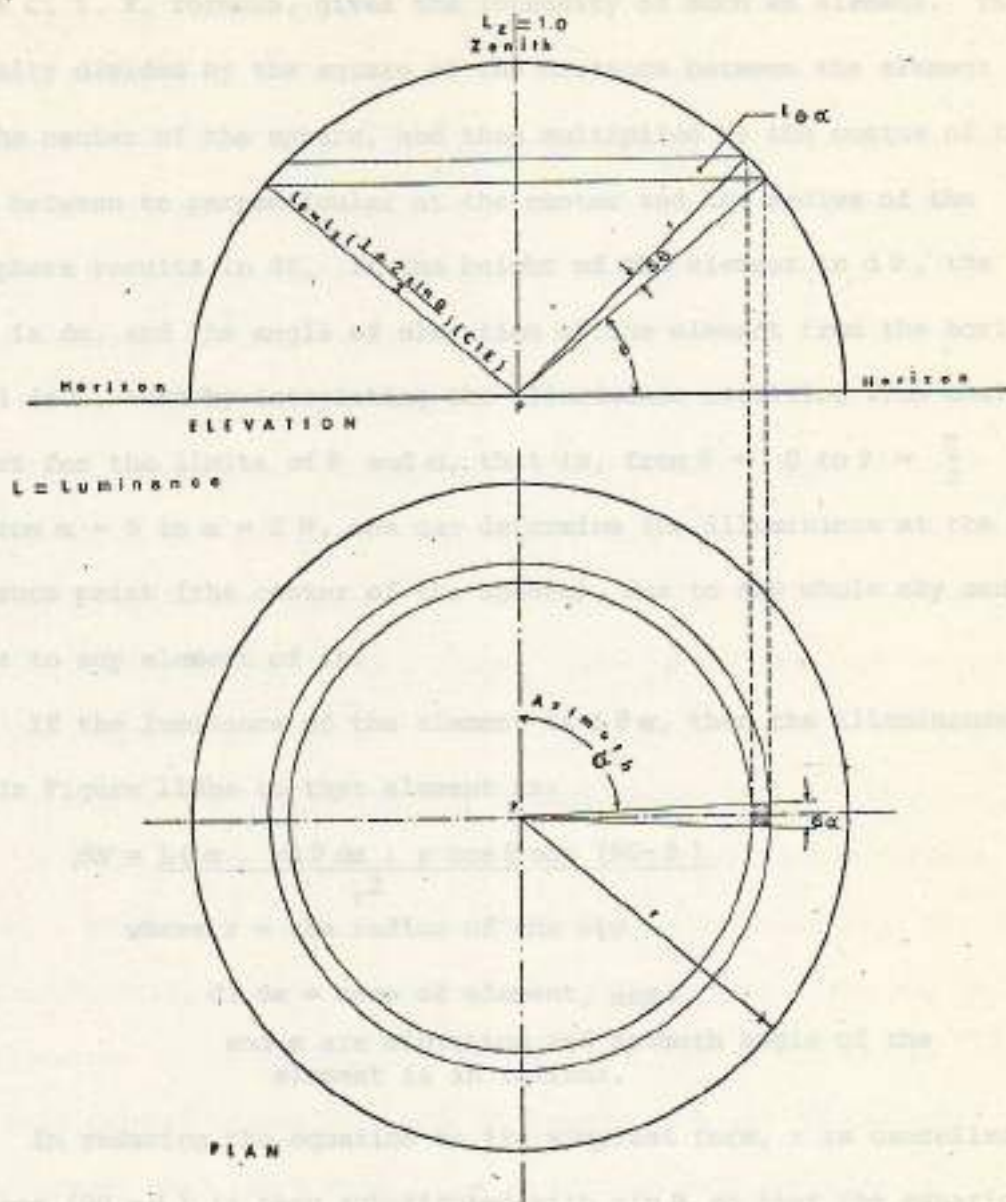

Fig 11 Sky component due to an element of CIE overcast sky at a reference point 'P'

the sphere. Using E to represent the illumination of the whole sky at center point P , the dE is the illumination from an element of the sky the area of such an element multiplied by the luminance, according to the C. I. E. formula, gives the intensity of such an element. This intensity divided by the square of the distance between the element and the center of the sphere, and then multiplied by the cosine of the angle between to perpendicular at the center and the radius of the hemisphere results in dE . If the height of the element is $d\theta$, the width is $d\alpha$, and the angle of elevation of the element from the horizontal is θ , then by integrating the illuminance resulting from that element for the limits of θ and α , that is, from $\theta = 0$ to $\theta = \frac{\pi}{2}$ and from $\alpha = 0$ to $\alpha = 2\pi$, one can determine the illuminance at the reference point (the center of the sphere), due to the whole sky and/or due to any element of it.

If the luminance of the element is $L\theta\alpha$, then the illuminance at P in Figure 11 due to that element is:

$$dE = \frac{L\theta\alpha \cdot r d\theta d\alpha \cdot r \cos\theta \cos(90-\theta)}{r^2}$$

where r = the radius of the sky

$d\theta d\alpha$ = area of element, and θ

and α are elevation and azimuth angle of the element is in radians.

In reducing the equation to its simplest form, r is cancelled out; $\cos(90-\theta)$ is then substituted with $\sin\theta$ so that the equation becomes $dE = L\theta\alpha \cos\theta \sin\theta d\theta d\alpha$. According to the C. I. E. relative luminance distribution, $L\alpha$ equals $L_2 \left(\frac{1 + 2 \sin\theta}{3} \right)$; therefore this value has been substituted in the former equation. By integrating

the product for the limits of θ and α then:

$$dE = \frac{L_z}{3} \int_0^{\theta_2} \int_0^{\alpha_2} \cos \theta \sin \theta + 2 \cos \theta \sin^2 \theta \, d\theta \, d\alpha \dots\dots\dots (1)$$

For the whole sky

$$E = \frac{L_z}{3} \int_0^{\frac{\pi}{2}} \int_0^{2\pi} \cos \theta \sin \theta + 2 \cos \theta \sin^2 \theta \, d\theta \, d\alpha \dots\dots (2)$$

It is now possible to construct a protractor which consists of the sky hemisphere divided into a multitude of elements and projected on to its plan. By solving equation #1 with respect to the element's area, elevation, and azimuth angles, one can obtain numerical values for sky components. These values are written inside the projection of the elements and should be regarded as representing a percentage of the total sky factor. For example, if an element reads .47, the illumination at the reference point due to this element is .47 percent. It should be noted that since these quantities are confined to two decimals, this will result in a slight error in the total sky component which equals 0.03 percent. This is sacrificed to give the protractor the advantage of having a practical value.

In using the protractor, the center P represents a reference point on a horizontal plane. The azimuth angles are read from the square surrounding the circle and are designed to permit the use of the protractor in any orientation or position. Since the radial lines read azimuth angles for each 10 degrees, the arc of the outer circle between each two radial lines is divided into 10 units of one degree each. The circular lines are for angles of elevation (see Figure 12.)

To calculate the S_c at a reference point in the interior from drawings, both plans and sections are required, no matter what their

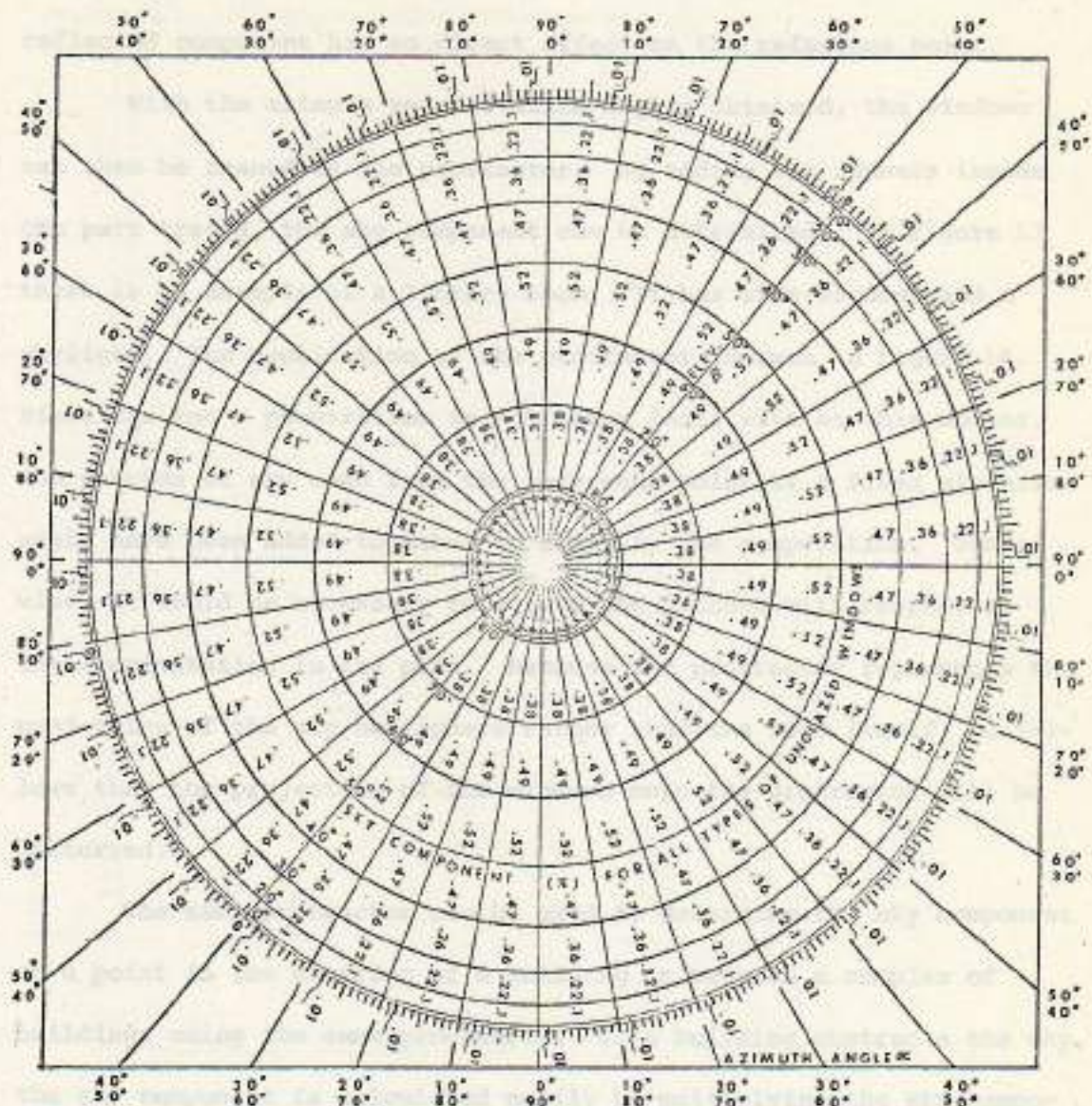

Radial lines for azimuth angles
 Circular lines for angles of elevation

Fig. 12 PROTRACTOR FOR "CIE" OVERCAST SKY.
 (UNGLAZED WINDOW)

scales are. From the reference point, project straight lines to the effective sides of the windows. It is important that the angle of elevation be measured from the horizontal since the part of the window under the reference point, although contributing to the internally reflected component has no direct effect on the reference point.

With the azimuth and elevation angles obtained, the windows can then be traced on the protractor. By adding the numbers inside the part traced, the sky component can be determined. In Figure 13 there is an example of a library room. It has side windows and a skylight. The application of the protractor is seen in Figure 14. Since the sun's penetration is not being dealt with at this moment, the patches of sky seen from the reference point at a fixed elevation angle have been added together to simplify the computation. Otherwise, it would be necessary to locate the patches with respect to their orientation in the plan. Because the protractor represents the projection of the sky hemisphere rather than the room itself, it follows that the projection of the windows onto the protractor will be distorted.

The same protractor can be used to determine the sky component at a point in the exterior of a building or between a complex of buildings using the same procedures. If a building obstructs the sky, the sky component is calculated easily by multiplying the sky component obtained in the absence of this obstruction, by the reflectance of the surface material of that obstruction; it is as though the obstruction is a glass pane transmitting light with an efficiency equal to the reflectance of the obstruction.

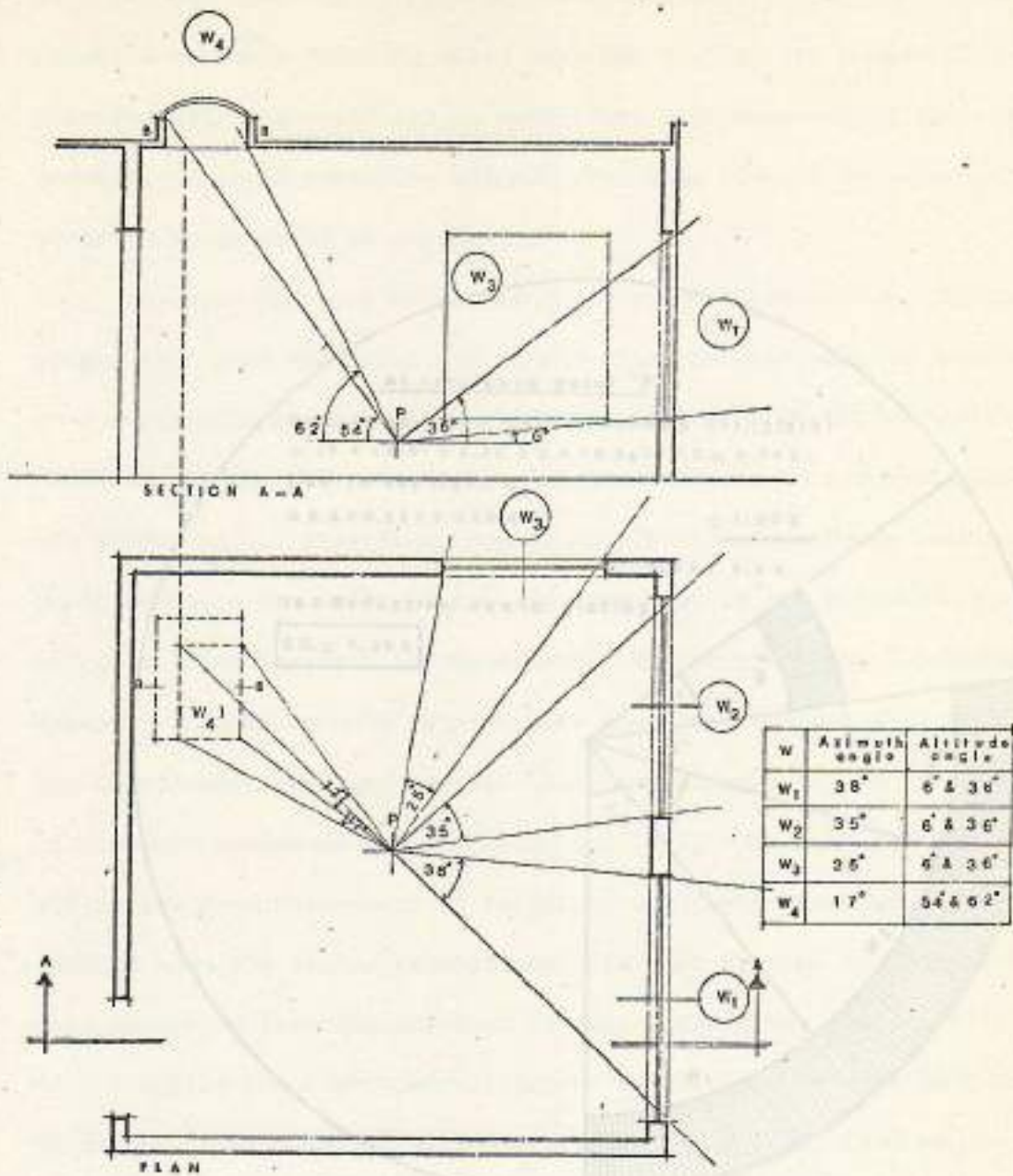

Fig 13 PLAN and SECTION of a room showing azimuthal sight lines and corresponding altitude angles

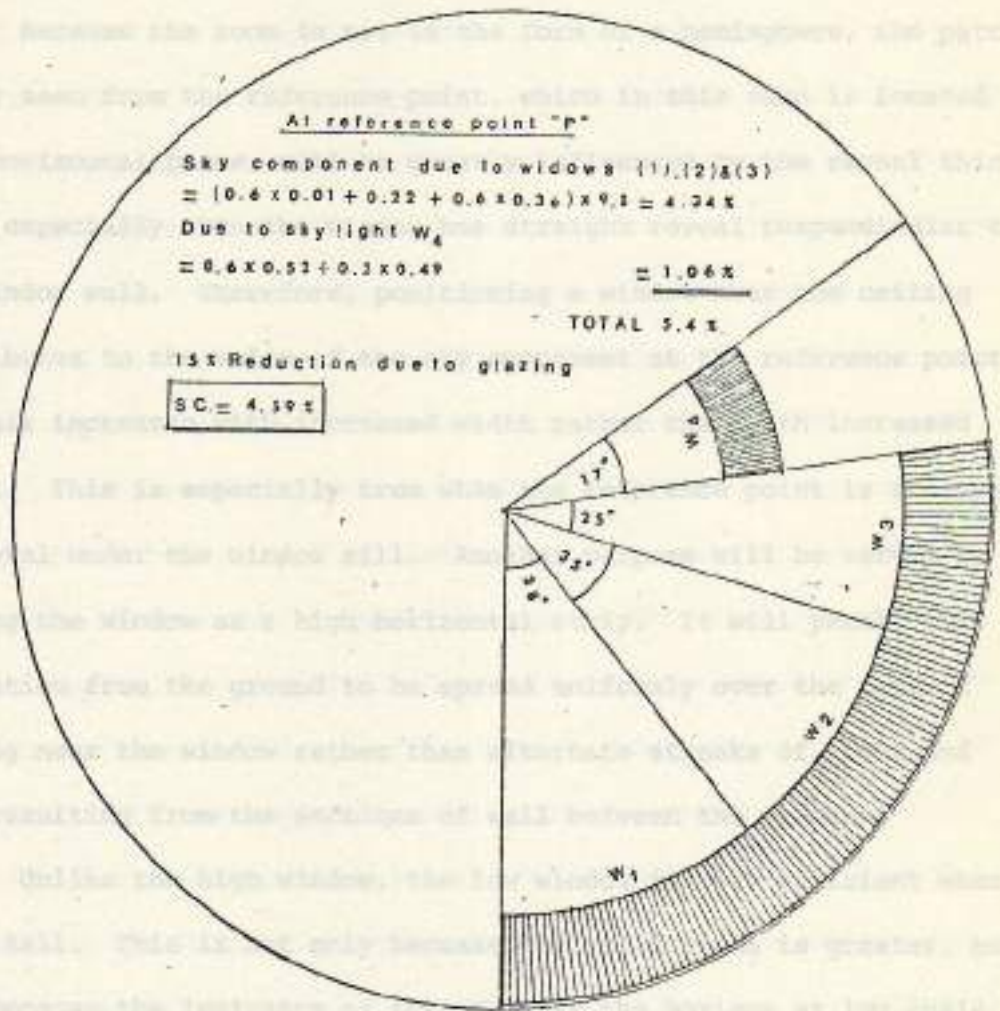

Fig 14 Method of calculating the sky component from example in fig 13 by the aid of the proposed protractor for "CIE" overcast sky

As can be seen from the distribution of elements in the protractor, the elements at the base near the horizon are very wide in relation to their heights, while near the zenith, the opposite occurs. This feature is a great aid to architects when they design for the quantity of light employing windows with deep reveals or external appendages functioning as sun breakers.

Because the room is not in the form of a hemisphere, the patch of sky seen from the reference point, which in this case is located on a horizontal plane, will be greatly influenced by the reveal thickness, especially when the window has straight reveal perpendicular to the window wall. Therefore, positioning a window near the ceiling contributes to the value of the sky component at the reference point and this increases with increased width rather than with increased height. This is especially true when the reference point is at a very low level under the window sill. Another purpose will be served by placing the window as a high horizontal strip. It will permit the reflection from the ground to be spread uniformly over the part of ceiling near the window rather than alternate streaks of light and dark resulting from the sections of wall between the windows.

Unlike the high window, the low window is more efficient when it is tall. This is not only because the solid angle is greater, but also because the luminance of the sky near the horizon at low angle elevation is about one third that of the zenith. Accordingly, a combination of both in the design will give higher performance than that achieved if each type is employed separately.

It may be argued that since more patches of sky seen from the

reference point will cause an increase in the sky component, why not remove the whole side of the room, separating it from the exterior to receive the maximum of light? This is true as far as a library reading room is concerned with respect to the quantity of light; however, increasing the quantity of light beyond the recommended level will cause other difficulties, including glare, disability glare, unbalanced brightness relationship within not only the immediate surroundings, but also the whole background, and distraction from concentration. Furthermore, the appearance of many silhouettes in the room causes a reduction in the reader's awareness of the reading room space and of the other readers. Finally, it causes a decrease in surfaces contributing to the internally reflected component; the internally reflected component resulting from the other surfaces of the room will escape from the window rather than being reflected back to the work. These problems have been discussed in detail in previous chapters. The concern here is that although the sum of the sky components at a reference point resulting from windows in different positions may be equal to that obtained from one big window, nevertheless, the distribution of light resulting from the latter is inferior to the former with respect to reading and writing. The reason for this is that in reading rooms, modeling is secondary in importance. In modern libraries where the books are not chained to the shelves and the reader is allowed to move freely in a big space, a wise distribution of windows will give the reader the freedom to take his book to any part of the room, to stretch his limbs to any position without being bothered by other readers intercepting light, as would be the case with one big

window. At the same time, adjacent or opposite windows illuminate each other's walls which reduces the contrast between the opening and the walls immediately surrounding it.

In addition to being essential as a tool for computing the sky component, the protractor can be used to control the distribution of light and the proportions of window openings. Since the protractor is the projection of the sky hemisphere where its center is the reference point, one assumes that there must be a relationship between the center and each element of the sky. The element near the horizon being at a low angle of elevation will spread its light over a greater area than does the element near the zenith, which is at the same distance from the point but with a different magnitude and angle of incidence.

The luminance of the one near the horizon is low and is spread over a greater area; the other near the zenith is high and its influence is confined in a smaller area at the center. This is represented as such in the protractor: the bigger areas have low values of sky component, and the smaller ones have greater values. It follows that if the library room is divided into equal bays, with the reference point being in the center of each bay, it will be easy to control the light reaching the point from the sides and from above, as found in nature, that is, in the ratio of 1:3. For example, if the sky component at the reference point is to be equal to 4 percent, then 3.0 percent should come from above and 1.0 percent from the sides. In other words, 75 percent of the light needed must come from higher angles of altitude and 25 percent from windows with lower sills.

The arrangement of the openings may be governed by either the structure itself or the obstruction facing the window, but the total distribution must be such that the light reaching the point must have a dominant directionality to restore the appearance of the space and its form. The dominant light here is from clearstories or skylights, not from side windows. For example, one can observe this principle by comparing the difference in lighting between the reading hall of Furnace Building of the University of Pennsylvania and the newly added study room perpendicular to it. Both have access to natural light, but because the hall depends for its lighting on clearstory windows rather than upon light coming from the sides, students prefer to read under the hall lighting conditions, in spite of its lower quantity of light.

Recently, the study room was furnished with carrels. The presence of these carrels helped to restore the original appearance of the adjacent hall by acting as light breakers and absorbers. This reduced the disability glare that was annoying the readers in the hall. In the meantime, it is not known whether the students will use these carrels or desert them since they have been there for only six months which is too short an interval of time to determine the exact reason for their abdication from the study room and whether there were other factors than lighting.

Since the libraries in the northern temperate zone do not receive light only from overcast sky conditions, determination needed to be made as to the anticipated intervals of overcast sky, their duration throughout the year, and whether a protractor could be con-

structed to enable the architect to know with a great degree of accuracy the conditions of light available at any location or orientation in that zone. To do this, the United States of America was chosen as the field of experimentation. The area of the study extends from latitude 32 degrees to 44 degrees North. The data used in this experiment was collected by one hundred seventy-five weather bureau station distributed throughout the United States of America during the period of 1931 to 1960¹⁶.

The method to be used in the following study design consists of four steps:

1. Determination will be made of the mean availability of overcast sky per hour of the day for latitudes 32 degrees, 36 degrees, 40 degrees, and 44 degrees North.
2. A sun path diagram will be developed to be employed during the hours from 9:00 A.M. until 4:00 P.M., which is considered to be the time necessary for sun control in reading rooms. (The sun diagram will have information obtained from step one)
3. A sun angle protractor will be developed to estimate the probability of sun and overcast sky, to measure the angles of incidence, and to give answers to the methods of sun control according to the orientation of the exposed library windows and its skylights. This can be done when step two and three are combined.

¹⁶U. S. Department of Commerce: Environmental Science Service Administration, Weather Atlas of the United States, June 1968, reprinted 1975 by Gale Research Company, Michigan, pp. 190-207.

4. The use of the sun path diagram will be demonstrated with the overcast sky protractor to achieve a balanced design for various components of light according to location, orientation, and season of the year.

It should be noted that part of step two in this work resembles in idea, though different in method and application, a previous work done in England by Ne'eman, Light and Hopkinson¹⁷. The point of similarity lies in the fact that this study and theirs relied on weather center data. Hopkinson and his partners have chosen the 21st of each month as a design criteria, because in my opinion, they were restricted by the plan of the sky vault, as used by Petherbridge and others, where each month has different hours of sunshine. In the current study herewith, this problem was solved by choosing the daily time period of 9:00 A.M. to 4:00 P.M. which is a common segment of daytime for all the months. Their data were obtained from one weather center (London) and they used these to cover the latitude 51 to 5 degrees North. Unlike these authors, I obtained data from several stations so that at least twenty-seven stations were employed to cover the data required for each latitude.

Because of the difference between the lighting condition of the United States of America, and England, the data presented in the protractor of Ne'eman, Light, and Hopkinson is in terms of average

¹⁷ E. Ne'eman, Wendy Light, R. G. Hopkinson: Recommendations for the Admission and Control of Sunlight in Buildings, Building and Environment, vol. 11, pp. 91-101, Pergamon Press 1976, Printed in Great Britain.

E. Ne'eman, Wendy Light: Availability of Sunshine, Building and Environment, vol. 11, pp. 103-130, Pergamon Press 1976, Printed in Great Britain.

hourly values of available sunshine. Unlike theirs, my sun diagram contains information regarding the mean number of hours of overcast sky. From this point on the two methods mentioned above followed different approaches.

In step one, I arranged the data obtained from different weather stations according to their location on and near each latitude to cover the whole breadth of the United States. Since the data obtained were in terms of the mean number of hours of sunshine per month, the information was used to obtain the possible duration of overcast sky per hour of that month. The method of calculation is shown in the attached tables. See Figures 8, 9, 10, and 11.

The reason why data were not employed for a specific day in a month was that the condition of light in America according to my observations is changeable. While on day is clear and sunny, the other day is cloudy and rainy. At the same time, it may be overcast in a nearby state, while another state at the same latitude enjoys a sunny day; the opposite may occur the next day. To be on the safe side, I studied the condition of light for the whole month and then solved the problem of the different lengths of the days. The mean number of hours of sunshine was divided by the average lengths of the days of the month in question; the design period was then confined to the hours from 9:00 A.M. till 4:00 P.M. One reason for this limitation is that the sun is at a steep angle before or after this span of time. Another reason is that the solutions employed for controlling the sun in the designed hours are more than sufficient in cases where the sun is located away from the center of the window. When the

Mean Numbers of Hours of Sunshine for Latitude 32 Degrees North

Station on or near Latitude 32 degrees N.	JAN	FEB	MAR	APR	MAY	JUN	JUL	AUG	SEP	OCT	NOV	DEC
Austin	148	152	207	221	266	302	331	320	261	242	180	160
Corpus Christi	160	165	212	237	295	329	366	341	276	264	194	164
Del Rio	173	173	230	237	259	279	331	319	252	240	195	178
El Paso	234	236	299	329	373	369	336	327	300	287	257	236
Houston	144	141	193	212	266	298	294	281	238	239	181	146
Jacksonville	192	189	241	267	296	260	255	248	199	205	191	170
Mobile	157	158	212	253	301	289	249	259	235	254	195	146
New Orleans	160	158	213	247	292	287	260	269	241	260	200	157
Pensacola	175	180	232	270	311	302	278	284	249	255	206	166
San Antonio	148	153	213	224	258	292	325	307	261	241	183	160
Tampa	223	220	260	283	320	275	257	252	232	243	227	209
TOTAL	1914	1925	2612	2780	3257	3277	3282	3207	2744	2225	2209	1892
Average	174	175	237.45	252.73	296.09	297.91	298.36	291.55	249.45	202.27	200.82	172.

TABLE 8 Probability of overcast sky duration for Latitude 32 degrees North.

Continued.

Continued. TABLE 8

For Stations on or near Latitude 32 Degrees North	JAN	FEB	MAR	APR	MAY	JUN	JUL	AUG	SEP.	OCT	NOV	DEC
Daily Average sunshine in hours	$\frac{174}{31}$ =5.61	$\frac{175}{29}$ =6.03	$\frac{237.45}{31}$ =7.66	$\frac{252.73}{30}$ =8.42	$\frac{296.09}{31}$ =9.55	$\frac{297.91}{30}$ =9.93	$\frac{298.36}{31}$ =9.62	$\frac{291.55}{31}$ =9.40	$\frac{249.45}{30}$ =8.32	$\frac{202.27}{30}$ =6.74	$\frac{200.82}{30}$ =6.69	$\frac{172}{31}$ =5.55
Average Duration of sunshine per hour,	$\frac{5.61}{10.50}$ = .53	$\frac{6.03}{11.22}$ = .54	$\frac{7.66}{12}$ = .64	$\frac{8.42}{12.94}$ = .65	$\frac{9.55}{13.64}$ = .70	$\frac{9.93}{14}$ = .71	$\frac{9.62}{13.64}$ = .71	$\frac{9.40}{12.94}$ = .73	$\frac{8.32}{12}$ = .69	$\frac{6.52}{11.22}$ = .58	$\frac{6.69}{10.50}$ = .64	$\frac{5.55}{9.88}$ = .56
Probable duration of overcast sky/hour,	.47	.46	.36	.35	.30	.29	.29	.27	.31	.42	.36	.44

* Data in these tabulations are based on U. S. A. Weather Bureau records from black-bulb type sunshine recorders during the period from 1931 to 1960.

Probability of overcast duration for Latitude 32 degrees North (U.S.A.).

TABLE 9. Probability of overcast sky duration for Latitude 36 degrees North. (Continued.)

Mean Number of Hours of Sunshine for Latitude 36 Degrees North

Station on or near Latitude 36 degrees N.	JAN	FEB	MAR	APR	MAY	JUN	JUL	AUG	SEP	OCT	NOV	DEC
Abilene	190	199	250	259	290	347	335	322	276	245	223	201
Albuquerque	221	218	273	299	243	365	340	314	299	279	245	219
Amarillo	207	199	258	276	305	338	350	328	288	260	229	205
Asheville	146	161	211	247	289	292	268	250	235	222	179	140
Atlanta	154	165	218	266	309	304	284	285	247	241	188	160
Birmingham	138	152	207	248	293	294	269	265	244	234	182	136
Cape Hatteras	152	168	206	259	293	301	286	265	214	202	169	154
Charleston	188	189	243	284	323	308	297	281	244	239	210	187
Charlotte	165	177	230	267	313	316	291	277	247	243	198	167
Chattanooga	126	146	187	239	290	295	278	266	247	220	169	128
Dallas	155	159	220	238	279	326	341	325	274	240	191	163
Fresno	153	192	283	330	389	418	435	406	355	306	231	144
Fort Smith	146	156	202	234	268	303	321	305	261	230	174	147
Greensboro	157	171	217	231	298	302	287	272	243	236	190	183
Knoxville	124	144	189	237	281	288	277	248	237	213	157	120
Little Rock	143	158	213	243	291	316	321	316	265	251	181	142
Los Angeles	224	217	273	264	292	299	352	336	295	263	249	220
Macon	177	178	235	279	321	314	292	295	253	236	202	168
Memphis	135	152	204	244	296	321	319	314	261	243	180	139
Montgomery	160	168	227	267	317	311	288	290	260	250	200	156
Nashville	123	142	196	241	285	308	292	279	250	224	168	126

TABLE 9. Probability of overcast sky duration for Latitude 36 degrees North.

Continued.

Continued. TABLE 9

Station on or near Latitude 36 degrees N.	Mean Number of Hours of Sunshine for Latitude 36 Degrees North											
	JAN	FEB	MAR	APR	MAY	JUN	JUL	AUG	SEP	OCT	NOV	DEC
Norfolk	156	174	223	257	304	311	296	282	237	220	182	161
Oklahoma City	175	182	235	290	329	329	352	331	282	243	201	175
Phoenix	249	244	314	346	404	404	377	351	334	307	267	236
Prescott	222	230	293	323	378	392	323	305	315	286	254	228
Raleigh	154	168	220	255	290	284	277	253	224	215	184	156
Richmond	144	166	211	248	280	296	286	263	230	211	176	152
Roswell	218	223	286	306	330	333	341	313	266	266	242	216
San Diego	216	212	262	242	261	253	293	277	255	234	236	217
Shreveport	151	172	214	240	298	332	339	322	289	273	208	177
Tucson	255	266	317	350	399	394	329	329	335	317	280	258
Tulsa	152	164	200	213	244	287	314	308	281	241	207	172
Yuma	258	266	337	365	419	420	404	380	351	330	285	262
Wilmington	179	180	237	279	314	312	286	273	237	238	206	178
TOTAL	5912	6267	8091	9129	10576	11013	10740	10226	9131	8460	7033	5993
Average = $\frac{T}{34}$	173.88	184.33	237.97	268.5	311.06	323.91	315.88	300.76	268.56	248.82	206.85	176.26

Probability of overcast sky duration for Latitude 36 degrees North.

Continued.

Mean Number of Hours of Sunshine for Latitude 40 Degrees North

Station on or near Latitude 40 degrees N.	JAN	FEB	MAR	APR	MAY	JUN	JUL	AUG	SEP	OCT	NOV	DEC
Albany	125	151	194	213	266	310	317	286	224	192	115	112
Boston	148	168	212	222	263	283	300	280	232	207	152	148
Cheyenne	191	197	243	237	259	304	318	286	265	242	188	170
Chicago	126	142	199	221	274	300	333	299	247	216	136	118
Cincinnati	115	137	186	222	273	309	323	295	253	205	138	118
Cleveland	79	111	167	209	274	301	325	288	235	187	99	77
Columbus	112	132	177	215	270	296	323	291	250	210	131	101
Dayton	114	136	195	222	281	313	323	307	268	229	152	124
Denver	207	205	247	252	281	311	321	297	274	246	200	192
Dodge City	205	191	249	268	305	335	359	335	290	266	218	198
Grand Junction	169	182	243	265	314	350	249	311	291	255	198	168
Harrisburg	132	160	203	230	277	297	319	282	233	200	140	131
Indianapolis	118	140	193	227	278	313	342	313	265	222	139	118
Lincoln	173	172	213	244	287	316	356	309	266	237	174	160
New York	154	171	213	237	268	289	302	271	235	213	169	155
Philadelphia	142	166	203	231	270	281	288	253	225	205	158	142
Pittsburg	89	114	163	200	239	260	283	250	234	180	114	76
Pueblo	224	217	261	271	299	340	349	318	290	265	225	211
Reading	133	151	195	220	259	275	293	259	219	198	144	127
Reno	185	199	267	309	354	376	414	391	336	273	212	170
Salt Lake City	137	155	227	269	329	358	377	346	306	249	171	135

TABLE 10 Probability of overcast sky duration for Latitude 40 degrees North.

Continued.

Continued. TABLE 10 Mean Number of Hours of Sunshine for Latitude 40 Degrees North

Station or or near Latitude 40 degrees N.	JAN	FEB	MAR	APR	MAY	JUN	JUL	AUG	SEP	OCT	NOV	DEC
San Dusky	100	128	183	229	285	312	343	302	248	201	111	91
San Francisco	165	182	251	281	314	330	300	272	267	243	198	156
Scranton	108	138	178	199	251	269	290	249	213	183	120	105
St. Louis	137	152	202	235	283	301	325	289	256	223	166	125
Terre Haute	125	148	189	231	274	302	341	305	253	235	150	122
Toledo	93	120	170	203	263	296	331	298	241	196	106	99
Total	3806	4265	5623	6359	7590	8318	8844	7982	6916	5978	4224	3649
Average = $\frac{T}{27}$	140.95	157.96	208.26	235.52	281.11	308.07	327.56	295.63	256.15	221.41	156.44	135.15
Daily Average in hours	$\frac{140.95}{31}$ = 4.55	$\frac{157.96}{29}$ = 5.45	$\frac{208.26}{31}$ = 6.72	$\frac{235.52}{30}$ = 7.85	$\frac{281.11}{31}$ = 9.07	$\frac{308.07}{30}$ = 10.27	$\frac{327.56}{31}$ = 10.57	$\frac{295.63}{31}$ = 9.54	$\frac{256.15}{30}$ = 8.54	$\frac{221.41}{31}$ = 7.14	$\frac{156.44}{30}$ = 5.21	$\frac{135.15}{31}$ = 4.36
Average Dura- tion of Sun- shine/hour	$\frac{4.55}{10.77}$ = .42	$\frac{5.45}{11.05}$ = .49	$\frac{6.72}{11.90}$ = .56	$\frac{7.85}{12.94}$ = .61	$\frac{9.07}{13.61}$ = .67	$\frac{10.27}{14}$ = .73	$\frac{10.57}{13.61}$ = .78	$\frac{9.54}{12.94}$ = .74	$\frac{8.54}{11.90}$ = .72	$\frac{7.14}{11.05}$ = .65	$\frac{5.21}{10.77}$ = .48	$\frac{4.36}{8.76}$ = .50
Probable Dura- tion of over- cast sky/hour.	.58	.51	.44	.39	.33	.27	.22	.26	.28	.35	.52	.50

Probability of overcast sky duration for Latitude 40 degrees North,

TABLE 11 Probability of overcast sky duration for Latitude 40 degrees North. Continued.

Mean Number of Hours of Sunshine for Latitude 44 Degrees North

Station on or near Latitude 44 degrees N.	JAN	FEB	MAR	APR	MAY	JUN	JUL	AUG	SEP	OCT	NOV	DEC
Buffalo	110	125	180	212	274	319	338	297	239	183	97	84
Baker	118	143	198	251	302	313	406	368	289	215	132	100
Billings	140	154	208	236	283	301	372	332	258	213	136	129
Boise	116	144	218	274	322	352	412	378	311	232	143	104
Burlington	103	127	184	185	244	270	291	266	199	152	77	80
Detroit	90	128	180	212	263	295	321	284	226	189	98	89
East Port	133	151	196	201	245	248	275	260	205	175	105	115
Green Bay	121	148	194	210	251	279	314	266	213	176	110	106
Helena	138	168	215	241	292	292	342	336	258	202	137	121
Huron	153	177	213	250	295	321	367	320	260	212	142	134
Lander	200	208	260	264	301	340	361	326	280	233	186	185
Marquette	78	113	172	207	248	268	305	251	186	142	68	66
Mineapolis	140	166	200	231	272	302	343	296	297	193	115	112
Missoula	85	109	167	209	261	260	378	328	246	178	90	66
Portland	77	97	142	203	246	249	329	275	218	134	87	65
Rapid City	164	182	222	245	278	300	348	317	266	228	164	144
Rochester	93	123	172	209	274	314	333	294	224	173	97	86
Roseburg	69	96	148	205	257	278	369	329	255	146	81	50
Sheridan	160	179	226	245	286	303	267	333	266	221	153	145
Ste. Marie	83	123	187	217	252	269	309	256	165	133	61	62
Walla Walla	72	106	194	262	317	335	411	367	280	198	92	51
Total	2443	2967	4076	4769	5763	6172	7291	6479	5141	3928	2371	2094

TABLE 11. Probability of overcast sky duration for Latitude 44 degrees North. Continued.

Continued. TABLE 11

	JAN	FEB	MAR	APR	MAY	JUN	JUL	AUG	SEP	OCT	NOV	DEC
Average = $\frac{T}{21}$	116.33	141.29	194.1	227.1	274.43	293.9	347.19	308.52	244.81	187.05	112.9	99.71
Daily Average in hours	$\frac{116.33}{31} = 3.75$	$\frac{141.29}{19} = 4.87$	$\frac{194.1}{31} = 6.26$	$\frac{227.1}{30} = 7.57$	$\frac{274.43}{31} = 8.85$	$\frac{293.9}{30} = 9.80$	$\frac{347.19}{31} = 11.2$	$\frac{308.52}{31} = 9.95$	$\frac{244.81}{30} = 8.16$	$\frac{187.05}{31} = 6.03$	$\frac{112.9}{30} = 3.76$	$\frac{99.71}{31} = 3.22$
Average duration of sunshine per hour	$\frac{3.75}{9.49} = .40$	$\frac{4.87}{11} = .44$	$\frac{6.26}{12} = .52$	$\frac{7.57}{12.73} = .61$	$\frac{8.85}{13.50} = .66$	$\frac{9.80}{14} = .70$	$\frac{11.2}{13.50} = .83$	$\frac{9.95}{12.73} = .78$	$\frac{8.16}{12} = .68$	$\frac{6.03}{11} = .55$	$\frac{3.76}{9.49} = .40$	$\frac{3.22}{8.58} = .38$
Probability of overcast sky per hour	.60	.56	.48	.39	.34	.30	.17	.22	.32	.45	.60	.62

Probability of overcast sky duration for Latitude 44 degrees North.

sun faces the window and is low, this problem would normally be solved as libraries are usually built in cities or near a complex of buildings. The environment around the library building cuts the major part of the sun when it is low. In some occasions, it is possible to avoid this problem in the design phase by proper orientation. It may also be a good practice to allow some of the sunshine to enter library rooms before the readers use them so as to produce a healthy environment by curbing the dampness that accumulated during the evening study hours when the readers were breathing and sweating over all the materials in use. For example, because the sun is not allowed to penetrate the library room located in the basement of Drexel University of Philadelphia, Pennsylvania, the place is moist and the books are deteriorating.

The average hourly percentage of overcast sky are superimposed on the sun diagram of each latitude (see Figure 15). This is to facilitate ease of computation.

However, if more accuracy is required for a specific state or city, the attached tables, Figures 16 through 24 can provide the necessary information by following the same steps as indicated.

Similar diagrams can be obtained for any other location within the north temperate zone.

In step two, the four sun diagrams were placed in one chart to allow computation for localities in latitudes found midway between two latitudes either by taking the average of the two readings, or by proportioning according to the situation. This arrangement facilitated more practical use than four separate charts would have, as it

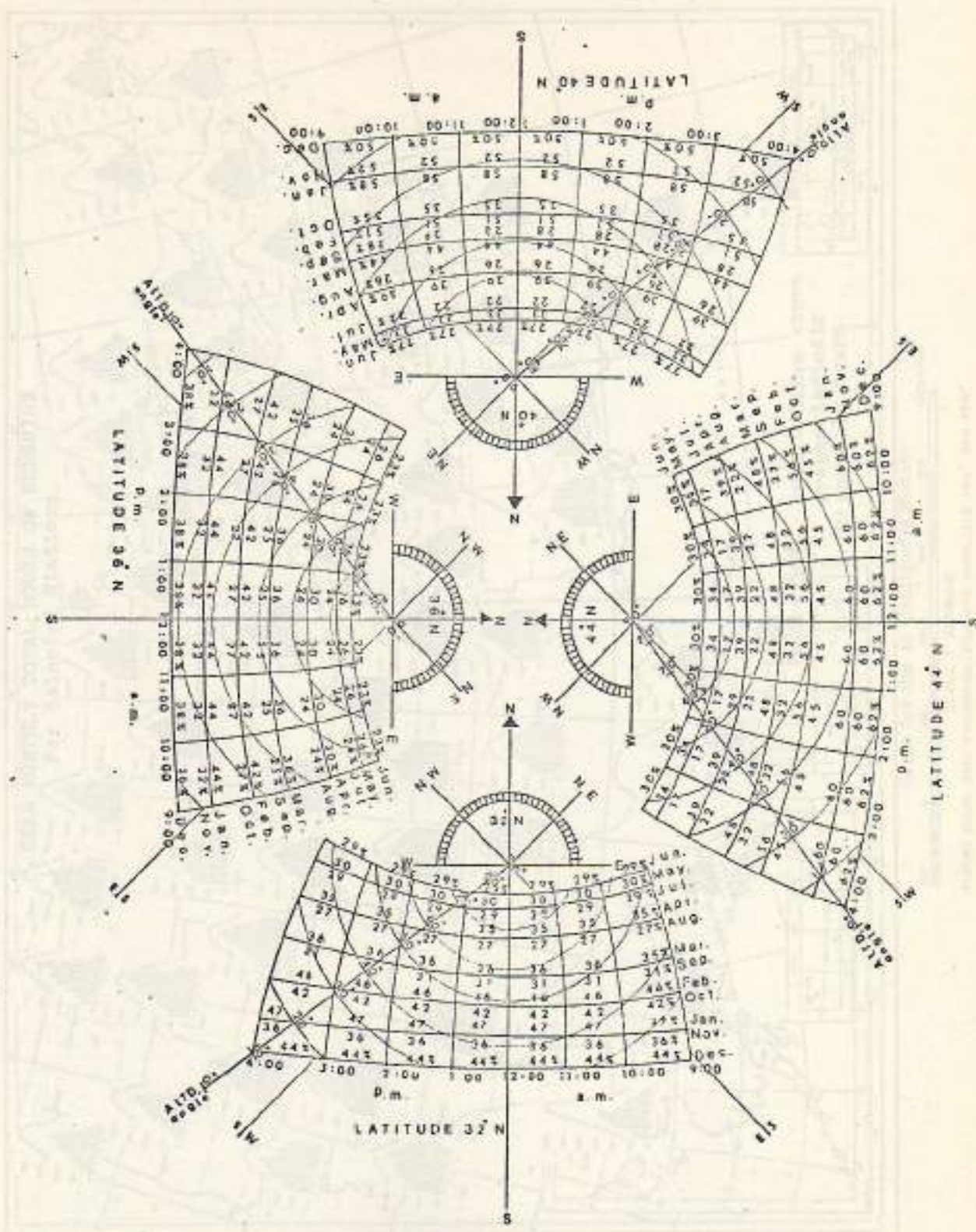

Figure 15 Sun diagram for the U. S. A. showing the percentage of overcast sky duration for each hour, from 9:00 AM to 4:00 PM throughout the months of the year for latitudes 32 degrees, 36 degrees, 40 degrees, and 44 degrees North.

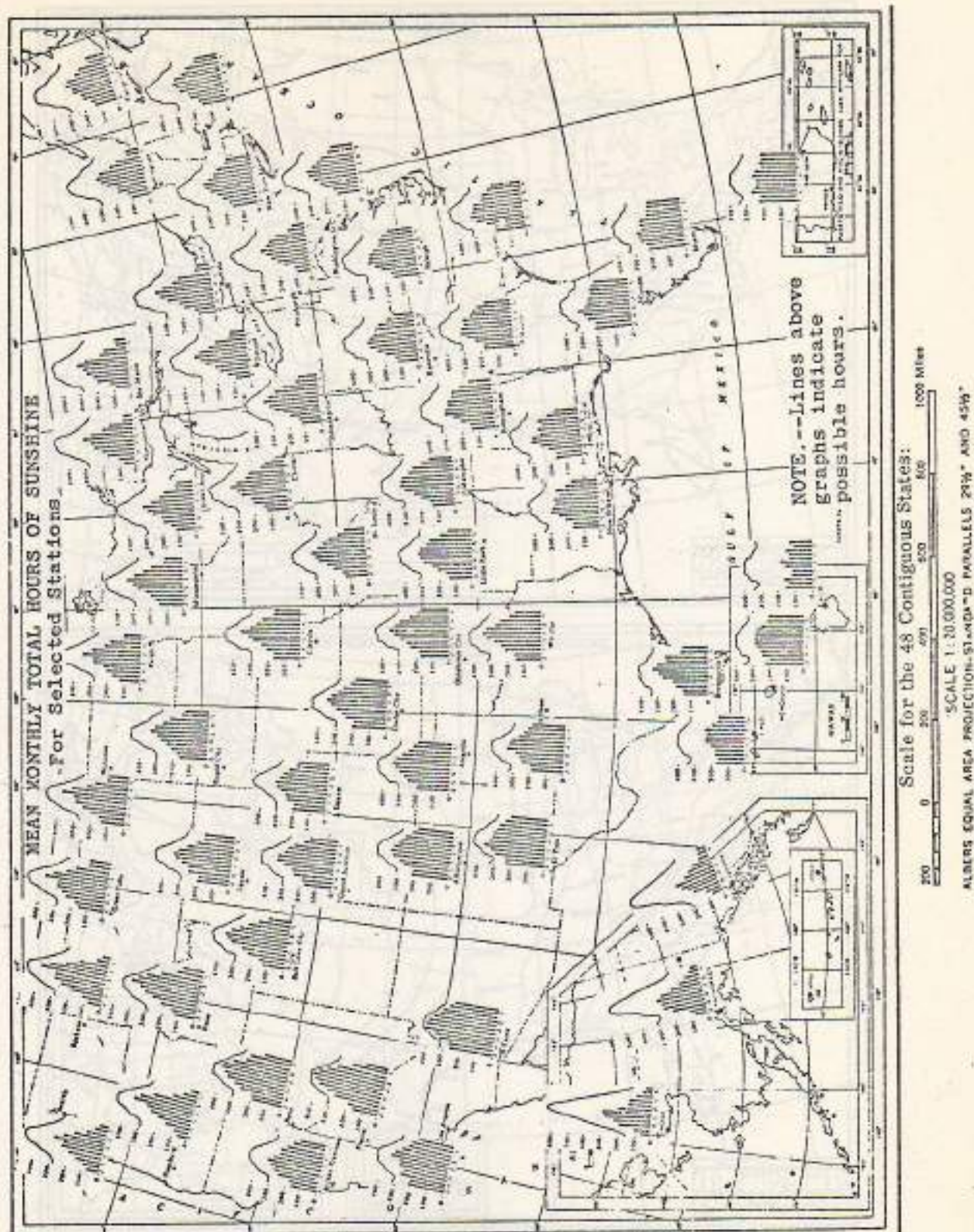

Figure 16 Mean monthly total hours of sunshine for selected stations in the United States (after U. S. Department of Commerce).

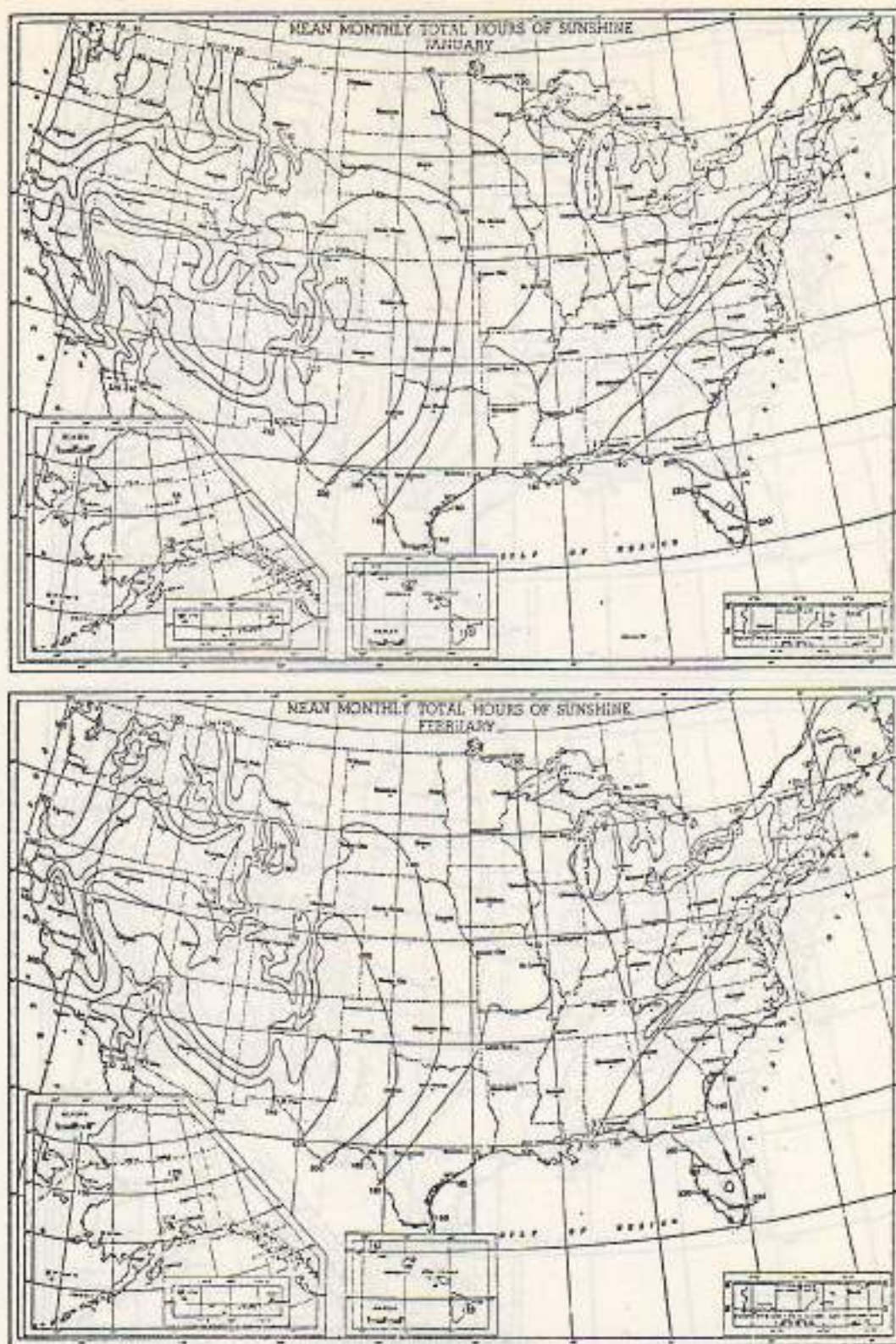

Figure 17 Mean monthly total hours of sunshine for January and February.
(after U. S. Department of Commerce)

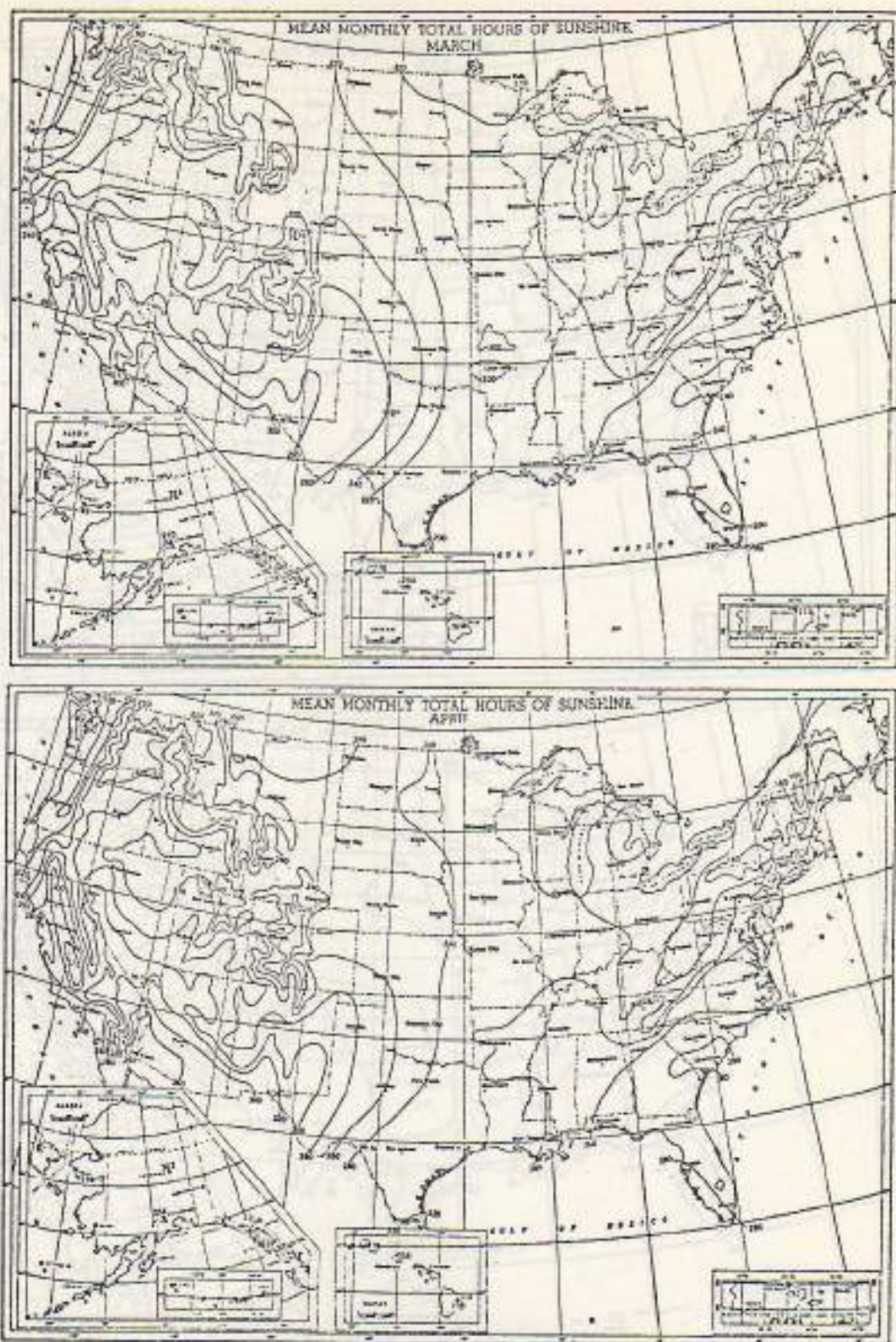

Figure 18 Mean monthly total hours of sunshine for March and April.
(after U. S. Department of Commerce)

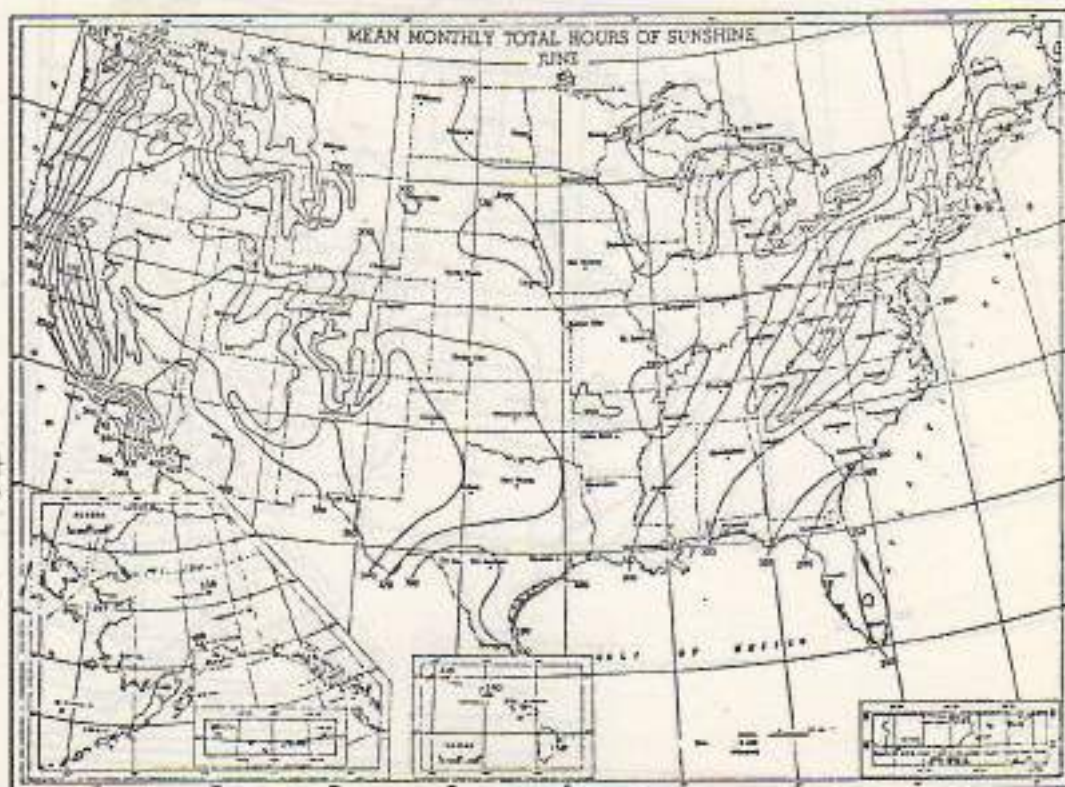

Figure 19 Mean monthly total hours of sunshine for May and June.
(after U. S. Department of Commerce)

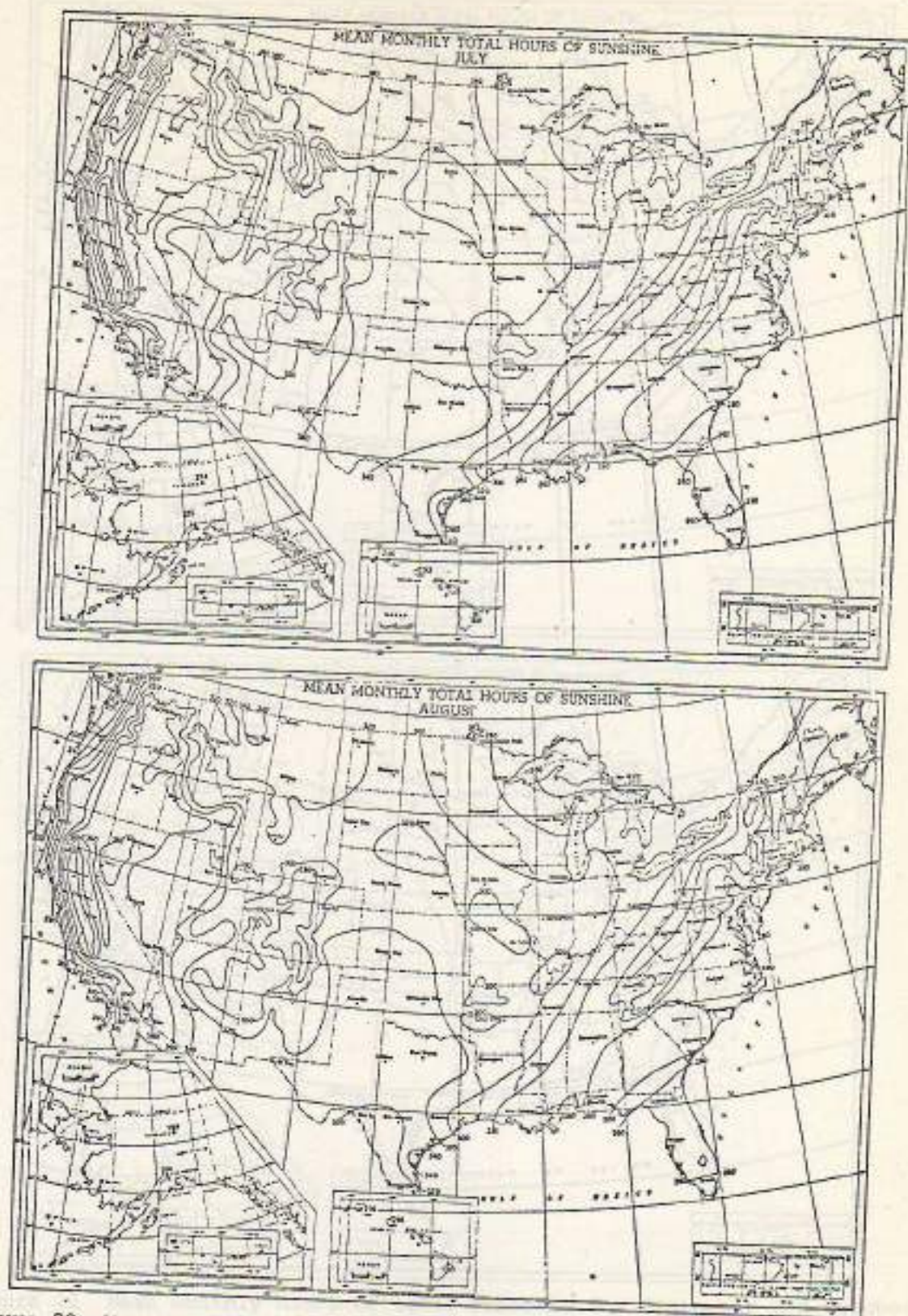

Figure 20 Mean monthly total hours of sunshine for July and August.
(after U. S. Department of Commerce)



Figure 21 Mean monthly hours of total sunshine for September and October.
(after U. S. Department of Commerce)

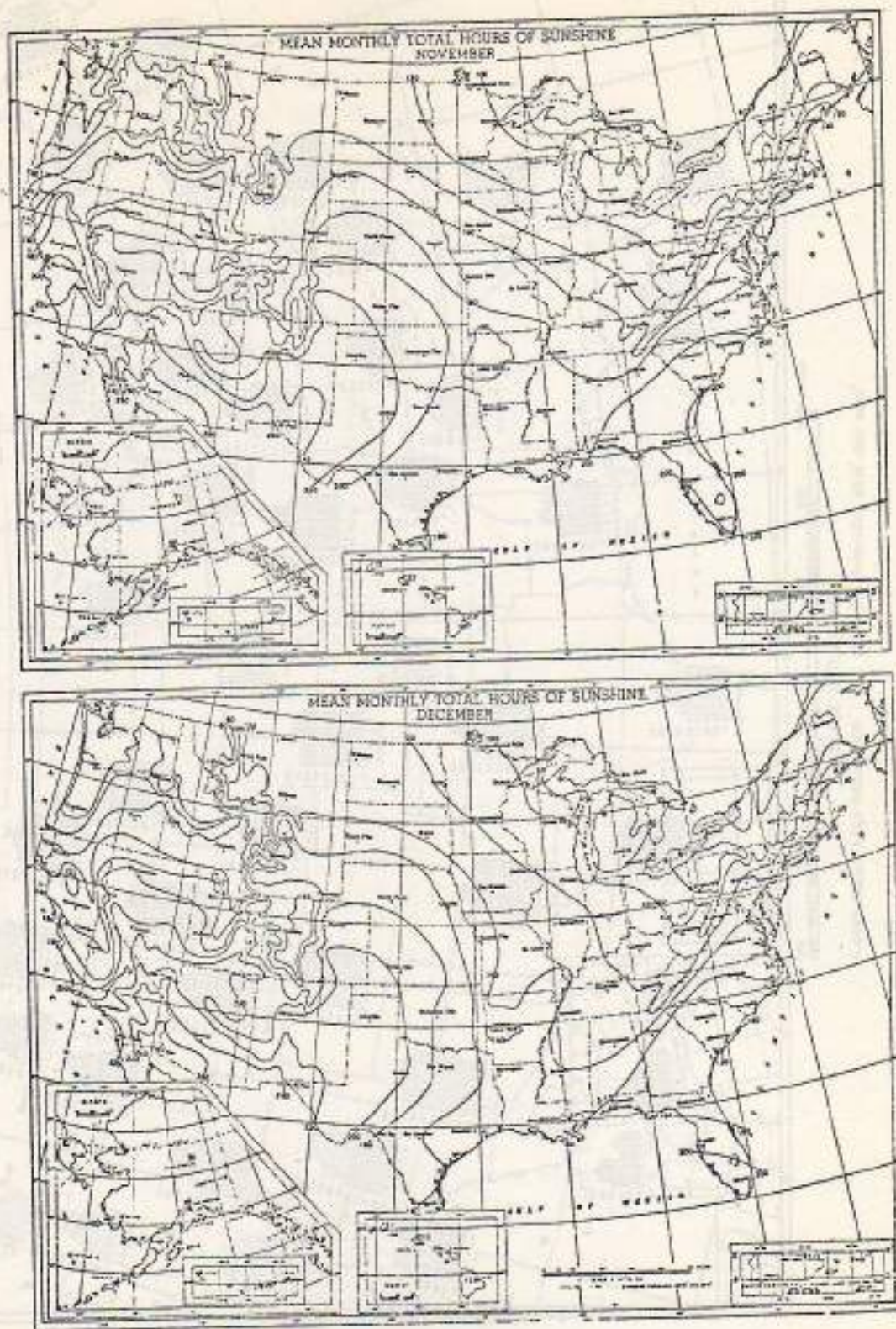

Figure 22 Mean monthly hours of total sunshine for November and December.
(after U. S. Department of Commerce)

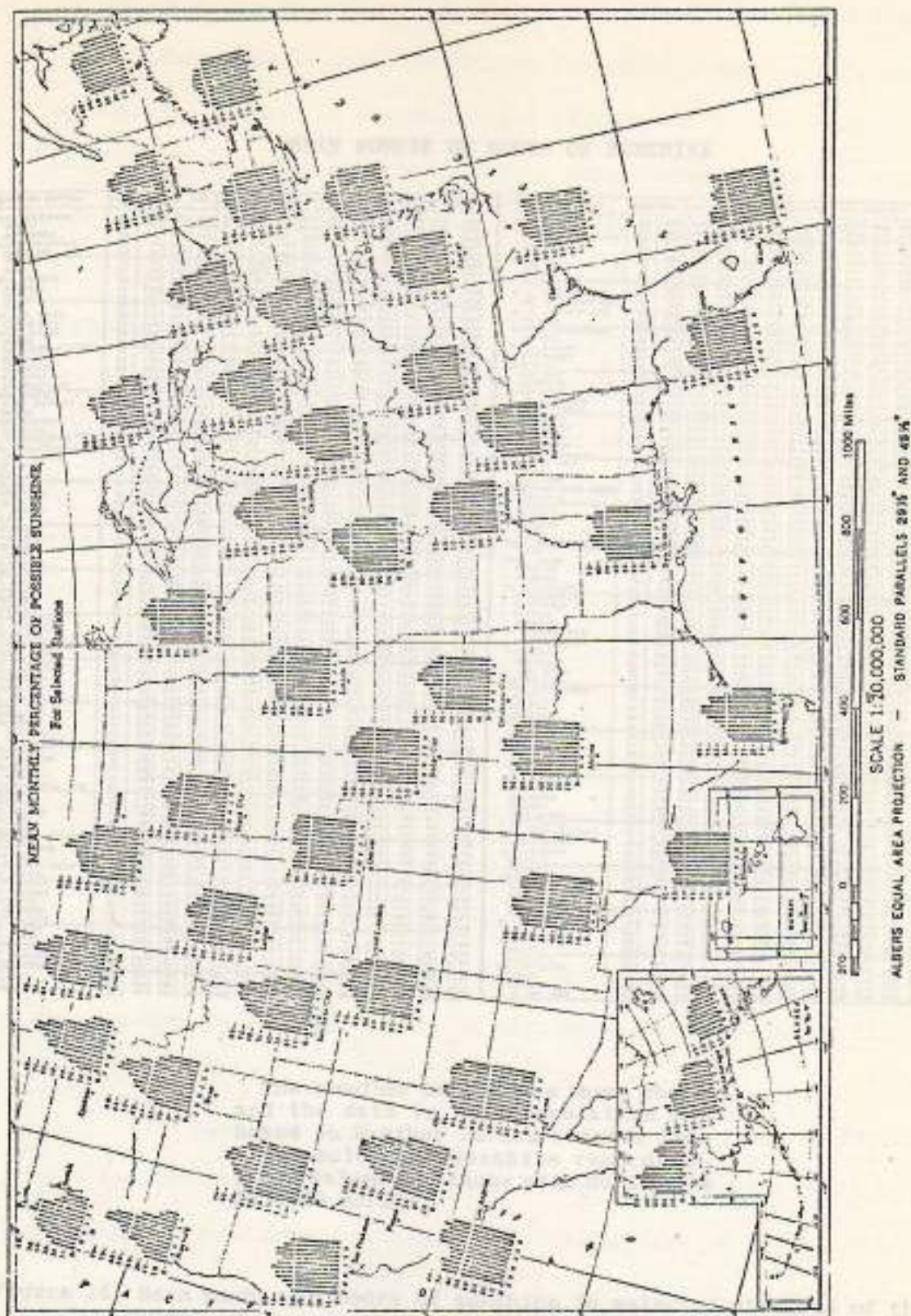

Figure 23 Mean monthly percentage of possible sunshine for selected stations in the U. S. A. (after U. S. Department of Commerce)

was designed for lighting conditions found only in the United States.

Every sun diagram, as seen in Figure 15 , has its geographic orientation located at the projection of the zenith on a horizontal plane. The sun's path is indicated by thick curved lines for each pair of identical months with respect to the zenith point. The curve-linear lines indicate the sun altitude at any time of the day, during any month of the year, but within the design's time frame. The diagram is divided vertically by curved lines to indicate the time of the day. The time can be read at the base of the diagram under the December sun path. The protractor, with its base oriented on the east-west axis, indicates the azimuth angle of the sun. For example, at twelve noon, the azimuth angle of the sun for all the months of the year is 90 degrees. Every division of the vernier reads 5 degrees.

The sun diagram, when used alone, can give only information regarding the location of the sun with respect to the geographic north. It is necessary to use it with the second protractor (the sun control protractor) to determine the sun angle with respect to a window differently oriented. The use of the sun diagram combined with the sun control protractor will be discussed after describing the latter.

The sun control protractor as shown in Figure 25 is developed from the Australian shadow angle protractor. Both follow the same principles established by Phillips¹⁸. The difference is that the sun

¹⁸R. G. Hopkinson, P. Petherbridge, J. Longmore: Daylighting, Heinemann, London 1963, pp. 499-500.

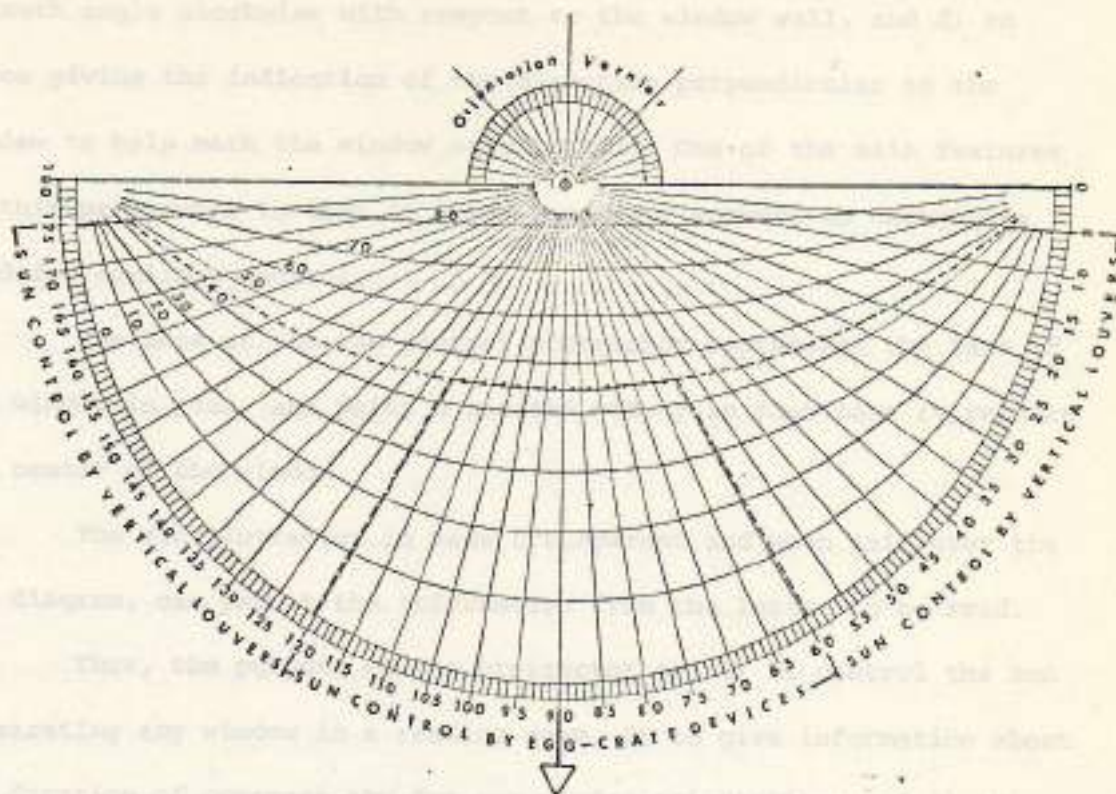

Radial lines - Horizontal angles of incidence 5° - 175° VAI
 Curved lines - Vertical angles of incidence 10° - 80° HAI

FIG 25 SUN CONTROL PROTRACTOR

control protractor has additions which facilitate its use with the sun diagram, as follows: a) the orientation vernier, b) the division of the protractor into three zones, c) the arrangement to read the azimuth angle clockwise with respect to the window wall, and d) an arrow giving the indication of the direction perpendicular to the window to help mark the window orientation. One of the main features of this protractor is that it gives immediate answers to techniques used for sunlight control.

The base of the sun control protractor represents the face of the window in plan, and point O located midway in that base represents the center of the window.

The sun protractor is made transparent and when laid over the sun diagram, can permit the information from the latter to be read.

Thus, the purpose of the protractor is: 1) to control the sun penetrating any window in a reading room, 2) to give information about the duration of overcast sky for any window orientation, and 3) to give answers to the solutions required for each setting, taking into consideration the obstruction on the site.

To simplify understanding of the use of these tools, first suppose the window in question has infinite width and is oriented due south. Then lay the transparent protractor on the sun diagram with the arrow pointing south and the base over the east-west direction. The part of the sun diagram seen from the transparency is that which will be acting on that infinite window throughout the year. The angles of incidence of the sun at any time of the day and the month can be read directly from the sun control protractor. The radial line indicates the horizontal angle of incidence, and the curved line shows

the vertical angle of incidence. The horizontal angle of incidence (H. A. I.) is to be drawn on the plan, and the vertical angle of incidence (V. A. I.) is for use with the section drawing of the window.

The reader will see also that the sun protractor is divided by a dotted curved line and two straight dotted lines creating four areas. The area limited by the curved dotted line and the base of the sun protractor can be excluded from the window by horizontal shades, whether by one horizontal deep shade or by a number of horizontal shades spaced in such a way as to not allow the sun to penetrate inside the room. This can be determined graphically in the section of the room (see Figure 26). On the other hand, the area of the diagram, as seen inside the trapezoidal shape of the sun protractor, can be removed by egg-crate devices. This can be done by drawing both the horizontal angle of incidence, and the vertical angle of incidence on the section. The projection and the spacing of the egg-crate can be determined graphically as before (see Figure 27). To remove the effect of the sun located to the right or to the left of this trapezoidal shape, the horizontal angle of incidence, as read from the sun protractor, must be drawn on the plan of the window. The vertical louvers should be designed to cut the rays of the sun in these directions. The direction of the inclination of such louvers around their vertical axes can be fixed at a certain angle or can be made variable if both the morning sun and the afternoon sun must be excluded completely.

If the window is not facing south, it is only necessary to rotate the sun control protractor so that the arrow points to the re-

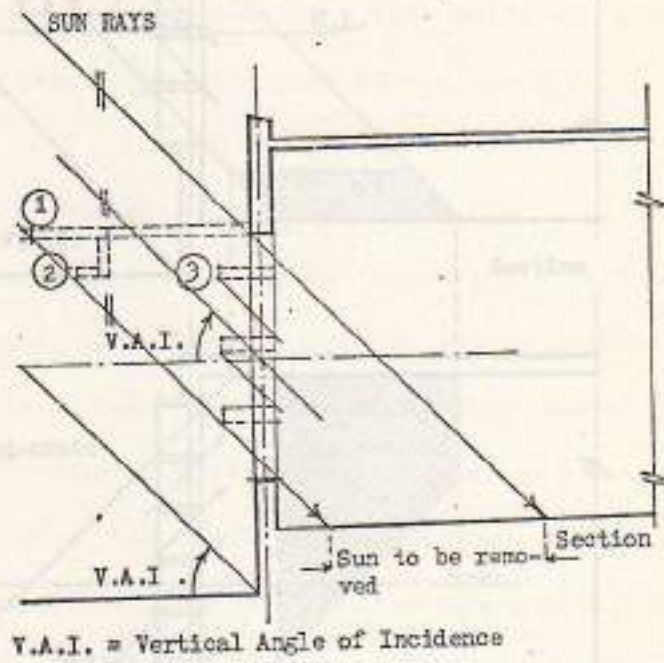

Fig 26

SECTION OF A ROOM SHOWING A
 GRAPHICAL DETERMINATION OF THREE
 DIFFERENT SOLUTIONS OF SHADES

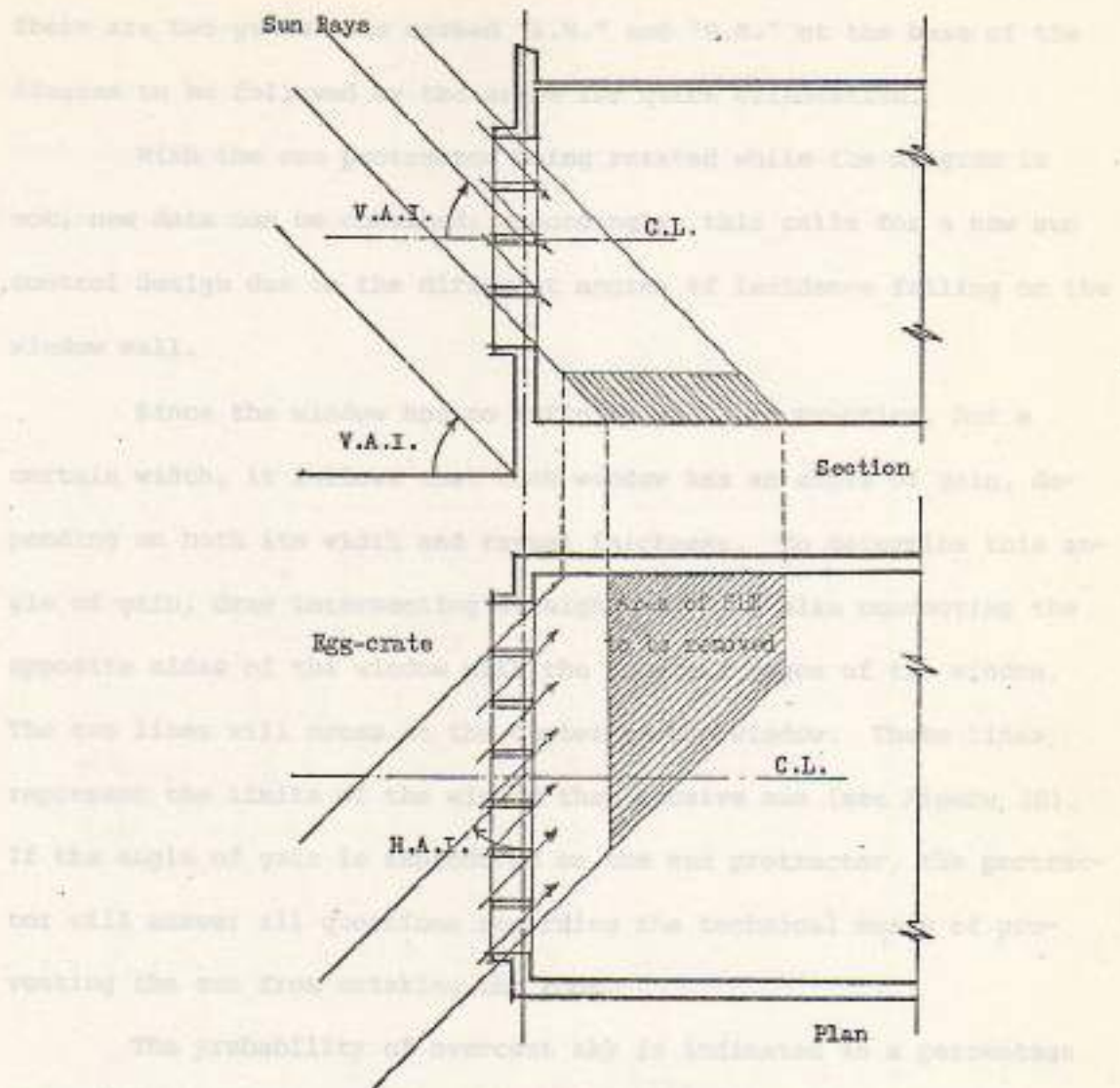

Fig 27

SECTION & PLAN SHOWING A GRAPHICAL
DETERMINATION OF AN EGG-CRATE SHADE

If the information obtained from the sun diagram is used in the protractor designed for an overcast sky, which was explained

quired orientation. In such a case, the orientation vernier found at the base of the sun protractor and the vernier drawn in the sun diagram will work together to determine the new orientation precisely. There are two guidelines marked "S.W." and "S.E." at the base of the diagram to be followed by the arrow for quick orientation.

With the sun protractor being rotated while the diagram is not, new data can be obtained; accordingly, this calls for a new sun control design due to the different angles of incidence falling on the window wall.

Since the window has no infinite width in practice, but a certain width, it follows that each window has an angle of gain, depending on both its width and reveal thickness. To determine this angle of gain, draw intersecting straight edges in plan connecting the opposite sides of the window with the internal edges of the window. The two lines will cross at the center of the window. These lines represent the limits of the window that receive sun (see Figure 28). If the angle of gain is reproduced on the sun protractor, the protractor will answer all questions regarding the technical means of preventing the sun from entering the room.

The probability of overcast sky is indicated as a percentage for each hour of the working day. This will determine the actual duration of sunshine for windows without sun controls and will help in the selection of the kind of glass needed, and the amount of heat gain during the day.

If the information obtained from the sun diagram is used in the protractor designed for an overcast sky, which was explained

Figure 28 Sketch showing method of determining the angle of gain for windows.

earlier in the study, one can determine the size and location of the windows in the library reading room with sufficient accuracy, since both are designed using the same scale. It will be seen that the sun breakers, while preventing the sun from penetrating the interior, will also reduce the sky component in overcast days. This will require additional windows to be opened to compensate for the losses caused by the presence of the sun breakers.

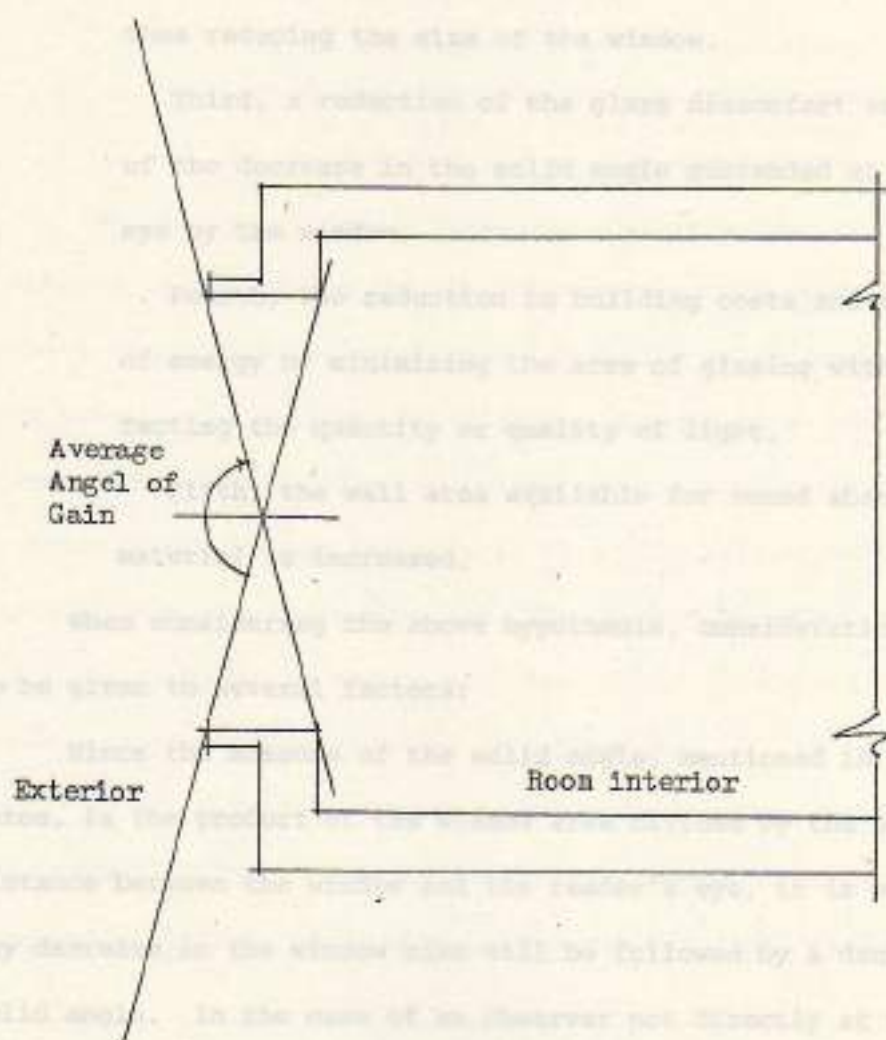

Figure 28 Sketch showing method of determining the average angle of gain for windows.

INFLUENCE OF THE WINDOW PROPORTION
UPON THE QUALITY AND QUANTITY OF LIGHT

My hypothesis is that by adjusting the window proportion, additional light and an improved quality can be obtained:

First, the maximum light from a given window area.

Second, an increase in the interreflected component due to a relative increase in the interior surfaces of the room thus reducing the size of the window.

Third, a reduction of the glare discomfort as a result of the decrease in the solid angle subtended at the reader's eye by the window.

Fourth, the reduction in building costs and the saving of energy by minimizing the area of glazing without affecting the quantity or quality of light.

Fifth, the wall area available for sound absorbant material is increased.

When considering the above hypothesis, consideration will need to be given to several factors:

Since the measure of the solid angle, mentioned in point number three, is the product of the window area divided by the square of the distance between the window and the reader's eye, it is evident that any decrease in the window size will be followed by a decrease in the solid angle. In the case of an observer not directly at the center line of the window, but at a line making an angle θ with the plane of the window, the solid angle is equal to the area of the window multiplied by $\sin \theta$ and then divided by the square of the distance

between the window and the observer.

Here is Hopkinson's¹ glare formula, which is a correction to the B. R. S. glare formula and is intended for use in computing the glare from large sources, for example, side windows:

$$B_s^{1.6} \delta = 0.8 G (B_d + 0.07 W^{0.5} B_s)$$

Where B_s is the luminance of the source

W is the solid angle unmodified by position

δ is the solid angle modified for its position in the field of view

B_d is the luminance of the surrounding field alone

G is the appropriate value of the glare constant for a degree of glare midway between just uncomfortable and just acceptable glare.

It can be noticed in Hopkinson's formula that the solid angular subtense of the source and the brightness of the surrounding field play a major role in determining the degree of glare discomfort. As has been stated earlier, by enlarging the interior surfaces, an increase in the interreflected component will result, provided that the surface finish of the interior is of a high reflectance. Furthermore, according to the above equation, the glare discomfort can be reduced if it is possible to reduce the size of the window without any decrease in the illumination of the interior.

It could be argued that instead of designing one big window, one can subdivide the window into a number of smaller windows to relieve the reader of discomfort and eye fatigue. In this respect, contra-

¹R. G. Hopkinson: Architectural Physics, Lighting, London: Her Majesty's Stationery Office, 1963, p. 231.

dictory answers have been given by two noted scientists, Rapoport and Hopkinson. Rapoport postulates that if, instead of the window, the wall is pierced vertically so that light can penetrate as streams, glare will be completely eliminated. In support of his conclusion, he gives an example of woven bamboo houses in Malaya². However, because of laboratory experiments done by Hopkinson, Rapoport's conclusions carry less weight. Hopkinson showed that breaking down the window into smaller elements will not reduce glare discomfort as the sum total glare from small areas is remarkably greater than the total produced by a singular large source³.

Glare discomfort is a subjective assessment and no one has yet proposed a universally agreed upon standard. In his "Lamp of Beauty" Ruskin stated that the eye's nerve cannot be as easily numbed as that of the ear - "The eye, it cannot choose but see"⁴. With respect to catering to subjective personal judgments regarding lighting conditions, Bombeck wrote:

"The people I know still wear dark glasses⁵ indoors even though they fall over things".

²Amos Rapoport: House Form and Culture, Englewood Cliffs, N.J., Prentice Hall, 1969, p. 103.

³R. G. Hopkinson: Architectural Physics, Lighting, London, Her Majesty's Stationery Office, 1963, p. 98.

⁴John Ruskin: The Seven Lamps of Architecture, Boston, Aldin Books Publishing Company, (189-), p. 114.

⁵Corwin Bennett: Spaces for People, Englewood Cliffs, N.J., Prentice Hall, 1977, p. 87.

When considering the fourth advantage of saving building costs and energy, one can safely say that the smaller the area of a single glazed window, the less heat transfer there will be between the interior and the exterior. Of course, double or triple glazing will reduce the annual cost of heating or cooling, but the initial capital cost will be much greater.

Although the area available for sound absorbing material is increased, this is not to say that solely by reducing the window area problems of sound and heat will be solved. However, under normal conditions, savings in both operating and capital costs can be anticipated.

... discomfort and therefore, the requirements under consid-
eration here is the need to transfer the measurement of discomfort
data from a subjective assessment to an objective one. By this ap-
proach we will not be distracted in trying to understand subjective
appraisals of light conditions, or by analyzing the brightness of
the surroundings and the eye's adaptation to these. The appreciation
of the lighting conditions of a place depends in a great extent upon
the subject's mood at the time of his judgment; for any given individ-
ual, one cannot know what the ideal lighting should be. Accordingly,
laboratory tests on subjects experiencing this matter should be re-
garded as conditional, either by outside restrictions or by the partic-
ipant's willingness to help. Another important observation is the
subject's shifting taste with the passing of time. Subjects who tests
in open view of his view is an artificial environment and therefore
tests to provide towards artificial environments with artificial
recreation for comfort, energy, productivity and so on. In this, such

METHODS OF MEASURING THE QUALITY

AND QUANTITY OF LIGHT BY OBJECTIVE STANDARDS

The primary objective of this study is to find out the reasonable window proportion that admits the maximum amount of light with the light quality being balanced in distribution.

The secondary objective is to reduce the window size to an appropriate dimension so as to increase the interreflected component of light and reduce the operating and capital costs.

Researchers to date have been unable to formulate a method of assessing glare discomfort and therefore, the key issue under consideration here is the need to transform the measurement of discomfort glare from a subjective assessment to an objective one. By this assessment we will not be distracted in trying to understand subjective appreciation of light conditions, or by analyzing the brightness of the surroundings and the eye's adaptation to these. The appreciation of the lighting conditions of a place depends to a great extent upon the subject's mood at the time of his judgment; for any given individual, one cannot know what the ideal lighting should be. Accordingly, laboratory tests on subjects concerning this matter should be regarded as conditioned, either by outside motivations or by the participant's willingness to help. Another important observation is the subject's shifting taste with the passing of time. Modern man tends to spend most of his time in an artificial environment and therefore tends to gravitate towards artificial environments with artificial recreation for comfort, study, recreation, and so on. In time, such

lighting conditions produce disorientation as there are no natural reference points. Modern man is forced to adapt to isolated interiors with their constant illumination levels. In such interiors he is not aware of the relationship between the time of the day and the lighting condition outside. Therefore, it would be doubtful that persons under such conditions would be able to give conclusive results when being asked about their appreciation or tolerance when comparing lighting compositions in laboratory tests.

The alternative is to return to the use of daylight where the distribution of natural light in the natural environment produces elation and a sense of well being. Our eyes function under such lighting without the fatigue that is produced by the artificial light. Assuming that the effects of natural light are preferable for the majority of people, one can compute a numerical relationship between the sunny and shaded areas in the external landscape. Our eyes sense the balance of this relationship, accept it and are pleased with it. The eyes are also accustomed to the connection between changes in shadow intensity and the causes for these changes in the composition of lighting. The brain is accustomed to translating this cause and effect relationship due to its former experience and learning. The interaction between the eye and the object viewed takes place immediately, because it is used to the innate relationship between light and shadow. In the natural landscape illuminated by the sun, there are no overlapping shadows. In days when the sky is overcast, in the absence of the sun, there are no individual shadows, as all things are in shade. The sun dictates the law of order, unity, and equilibrium,

order, in that there is no shadow without the sun, unity in the direction of the many shadows, and equilibrium between the intensities of light and darkness in the illuminated area. From the condition of light in the landscape, one can formulate a relationship that can be used as a standard of comfort when comparing it with the performance of different window proportions.

Since what the eye sees is the light leaving the object, measurements of the luminances of the natural soil are considered to be the base of a formula illustrating the above relationship. The reason is that the natural soil is a good diffuser, and it reflects light homogeneously. Unlike soil, water, snow and desert can cause loss of comfort due to the glare resulting from such surfaces. Likewise, artificial materials could distort the results if their surfaces acted as mirrors with different curvatures.

Readings taken of the brightness of the soil in the University of Pennsylvania (Table 12), show the following results:

a) The relation between the brightness of the sunny and shaded areas is an average of 1:0.12.

b) The relation between the luminance of the zenith and the horizon according to the C. I. E. overcast sky formula and the author's experiments, as shown in the previous chapter, is an average of 1:0.33.

From the above findings, a formula for a standard of acceptable brightness can be written as follows: 1:0.33:0.1. These results conform with Hopkinson's data which postulate that the light should be graded so that the eye is not subjected to harsh brightness differences

Experiment Number	Date and Time of Measurements		Brightness Sunny Soil Areas ft-L	Brightness Adjacent Shaded Soil Areas ft-L	Ratio
1	7/3/79	12:22 PM	400	60	1:0.15
2	7/3/79	12:22 PM	400	55	1:0.14
3	7/3/79	12:22 PM	365	50	1:0.14
4	7/3/79	12:22 PM	360	30	1:0.08
5	7/3/79	12:30 PM	325	28	1:0.09
6	7/3/79	12:30 PM	450	50	1:0.11
7	7/3/79	12:30 PM	600	65	1:0.11
8	7/3/79	12:30 PM	500	50	1:0.10
9	7/3/79	12:38 PM	500	55	1:0.11
10	7/3/79	12:38 PM	350	50	1:0.14
11	7/3/79	12:45 PM	325	28	1:0.09
12	8/9/79	3:00 PM	190	40	1:0.20
13	8/9/79	3:00 PM	225	30	1:0.13
14	8/9/79	3:10 PM	300	25	1:0.08
15	8/9/79	3:10 PM	175	26	1:0.15
16	8/9/79	3:18 PM	200	30	1:0.15
17	8/9/79	3:18 PM	150	30	1:0.20
18	8/9/79	3:25 PM	200	30	1:0.15
19	8/9/79	3:45 PM	240	20	1:0.08
20	8/9/79	3:45 PM	225	20	1:0.09
21	8/9/79	3:45 PM	200	28	1:0.14
22	8/9/79	3:55 PM	200	21	1:0.10
23	8/9/79	3:55 PM	200	20	1:0.10
24	8/9/79	3:55 PM	200	20	1:0.10
25	8/9/79	4:12 PM	200	50	1:0.15
26	8/9/79	4:12 PM	175	35	1:0.20
27	8/9/79	4:15 PM	200	30	1:0.15
28	8/9/79	4:15 PM	225	28	1:0.12
29	8/9/79	4:20 PM	240	28	1:0.12
30	8/9/79	4:20 PM	130	15	1:0.11
31	8/9/79	4:25 PM	120	14	1:0.12
32	8/22/79	1:30 PM	300	43	1:0.14
33	8/22/79	1:30 PM	280	40	1:0.14
34	8/22/79	1:35 PM	200	30	1:0.15
35	8/22/79	1:35 PM	200	28	1:0.14

TABLE 12

The relationship between the brightness of the sunny and the shaded areas of the soil at the Campus of the University of Pennsylvania.

Continued.

Continued.

TABLE 12

Experiment Number	Date and Time of Measurements		Brightness Sunny Soil Areas ft-L	Brightness Adjacent Shaded Soil Areas ft-L	Ratio
36	8/22/79	1:40 PM	250	30	1:0.12
37	8/22/79	1:45 PM	230	31	1:0.13
38	8/22/79	1:45 PM	250	28	1:0.11
39	8/22/79	1:50 PM	225	20	1:0.09
40	8/22/79	1:50 PM	230	30	1:0.13
41	8/27/79	2:25 PM	210	20	1:0.09
42	8/27/79	2:25 PM	210	22	1:0.10
43	8/27/79	2:30 PM	230	31	1:0.13
44	8/27/79	2:30 PM	230	30	1:0.13
45	8/27/79	2:35 PM	250	35	1:0.14
46	8/27/79	2:35 PM	230	30	1:0.13
47	8/27/79	2:40 PM	240	34	1:0.14
48	8/27/79	2:40 PM	220	29	1:0.13
49	8/27/79	2:45 PM	230	30	1:0.13
50	8/27/79	2:45 PM	180	22	1:0.12
51	8/27/79	2:45 PM	200	24	1:0.12
52	8/30/79	3:08 PM	140	33	1:0.23
53	8/30/79	3:12 PM	120	22	1:0.18
54	8/30/79	3:12 PM	130	23	1:0.18
55	8/30/79	3:18 PM	100	23	1:0.23
56	8/30/79	3:18 PM	110	20	1:0.18
57	8/30/79	3:20 PM	105	21	1:0.20
58	8/30/79	3:25 PM	125	18	1:0.14
59	8/30/79	3:25 PM	180	38	1:0.21
60	8/30/79	3:30 PM	100	20	1:0.20
61	8/30/79	3:30 PM	110	19	1:0.17
62	8/30/79	3:35 PM	100	20	1:0.20
63	8/30/79	3:35 PM	120	20	1:0.17

Average Ratio of Brightness = 1:0.12

The relationship between the brightness of the sunny and shaded areas of the soil at the Campus of the University of Pennsylvania.

in the visual field¹. A guide given in the I. E. S. Code² and derived from Hopkinson's data indicates that, at illumination levels of more than 30 lm/ft², the ratios of brightness which are comfortable to the eye should be 1:0.3:0.1, where "1" is the luminance of the object in focus, "0.3" is the luminance of the immediate surroundings, and "0.1" is the luminance of the background.

Accordingly, the luminance at the remote parts of the room should not drop to less than ten percent of that near the window. Also the intermediate ratio between the brightest and darkest areas of the room should be at least 30 percent of the brightness near the window.

From this relationship, one can determine the permissible working plane for a given window.

An important observation, which can be seen in Tables 14, 15, 16 and 17, is that the window that introduces an average of two percent sky component into the center of a room, complies with the suggested formula. The two percent sky component represents a ten lumens per square foot, if we consider the average sky illumination during over-cast days to be 500. This value of 500 lumens/square foot, though adopted internationally as being the standard condition of sky luminance, does not represent the actual lighting condition of the sky of the United States. The sky of the U. S. A. tends to be brighter, with 500 lumens/square foot representing the minimal sky condition present

¹R. G. Hopkinson, P. Petherbridge, J. Longmore: Daylighting, Heinemann, London, 1963, p. 11.

²Ibid., p. 11.

during the working day. However, the 10 lumens/square foot represents the average recommended level of illumination for school classrooms³.

Another observation is, when comparing two windows of equal areas, that are different in their proportions, the relationship between the quantity of light and the window dimensions proved to be dependent upon the ratio between the height and the width of the window rather than upon its area per se.

From Tables 14 and 15, it can be seen that where two windows are identical in area, but different in their proportions, the window that is taller introduces more light, and a better quality light. To demonstrate this, a window 15 feet tall and 7 feet wide will introduce more light than if positioned horizontally. For a given reference point of six feet away from the window's corner, the illumination from the horizontal window is 35.71 percent less than the same window positioned vertically. At distances of 12 and 18 feet the loss of light still increases. At 12 feet it is 45.47 percent and at 18 feet it is 56.18 percent. Losses that increase with distance indicate that the quality of light distribution is affected too by the window being horizontal rather than vertical. We have seen from the above example that at 18 feet, we have lost more than 50 percent of the light that could be obtained from the same window if it is positioned vertically. The ratios of light distribution at the above reference

³R. G. Hopkinson: Architectural Physics, Lighting, London, Her Majesty's Stationery Office, 1963, p. 27.

points are 1:0.37:0.15, in the case of the vertical window, and 1:0.31:0.12 in the case of the horizontal window. Both results meet the standard previously put forth as a measure for the quality of light, that is 1:0.3:0.1.

Windows of different geometrical shapes and size, although exposed to the same natural light source, have different capacities for distributing this light into the space illuminated by the window. This differing capacity to transmit light is the object of this study.

Moreover, accordingly, a closed window can be considered as equivalent to a mirror one since it reflects the space through. Special types of windows from the triangular family can be designed by the aid of the proposed partitions, explained earlier in the chapter of technical means of light modification.

Reference points at the level of the reading table, which is at the same height as the sill, have been selected perpendicular to one of the window corners at the sill's level. This facilitated the calculation due to the simple trigonometry involved. However, positioning the reference points perpendicular to the center of the window at the sill's level will result in a remarkable increase of illumination at these reference points. The reason is that both window halves are nearer to the reference point than in the former case where one half is near and the other half is at a distance equal to half the window. The window's illumination upon the reference point can be calculated by imagining the window as being connected to vanishing points. The position of these vanishing points will be dealt with later in the study. The greater the distance the other side of the window is from the reference point, the less it contributes to

DESIGN METHOD FOR MAXIMUM WINDOW PERFORMANCE

The aim of this chapter is 1) to study the effect of the window proportion upon the quantity of light, and 2) to demonstrate how to utilize the findings for the window design.

Three window shapes were selected for study: the vertical, the horizontal, and the square window. Any other shape of window, for the sake of simplification, will be abstracted to take one of the above shapes. Accordingly, a round window can be considered as equivalent to a square one since it fits into the square figure. Special types of windows from the triangular family can be designed by the aid of the proposed protractors, explained earlier in the chapter of technical means of light modification.

Reference points at the level of the reading table, which is at the same height as the sill, have been selected perpendicular to one of the window corners at the sill's level. This facilitated the calculation due to the simple trigonometry involved. However, positioning the reference points perpendicular to the center of the window at the sill's level will result in a remarkable increase of illumination at these reference points. The reason is that both window halves are nearer to the reference point than in the former case where one half is near and the other half is at a distance equal to half the window. The window's illumination upon the reference point can be calculated by imagining the window as being connected to vanishing points. The position of these vanishing points will be dealt with later in the study. The greater the distance the other side of the window is from the reference point, the less it contributes to

the illumination at that point. The higher the top of the window is above the sill, the more illumination there will be at the reference point. Figure 29 contains sketches illustrating the above ideas.

The following discussion supports this idea by means of computation and analysis. It should be noted however, that in the first part of this analysis, window areas were controlled relative to the locations of the reference points. The aim is to keep the level of illumination within the range recommended by the Illuminating Engineering Society of 30 foot candles for reading printed material, and 70 foot candles for studying and note taking¹. Accordingly, the reference point nearest the corner of the window was not permitted to receive more than 10 percent sky component. This means that in days with overcast sky when the illumination of the unobstructed sky is 1000 ft-c., then the illumination at the reference point will be not more than 100 ft-c. This is intended to give the study more practical value as the conditions are closer to the I. E. S. recommended levels for library reading rooms. However, in the second part of this study, the distribution of the reference points and their proximity to each other and to the window were kept constant while changing the window area and its proportions. This is useful in determining the rate of increase in illumination when areas are increased and related proportions are changed. At the same time, determination must be made as to whether there would be a limit to this increase in

¹John E. Kaufman (ed.): Illumination Engineering Society, IES, Lighting Handbook, 5th edition, New York, 1972.

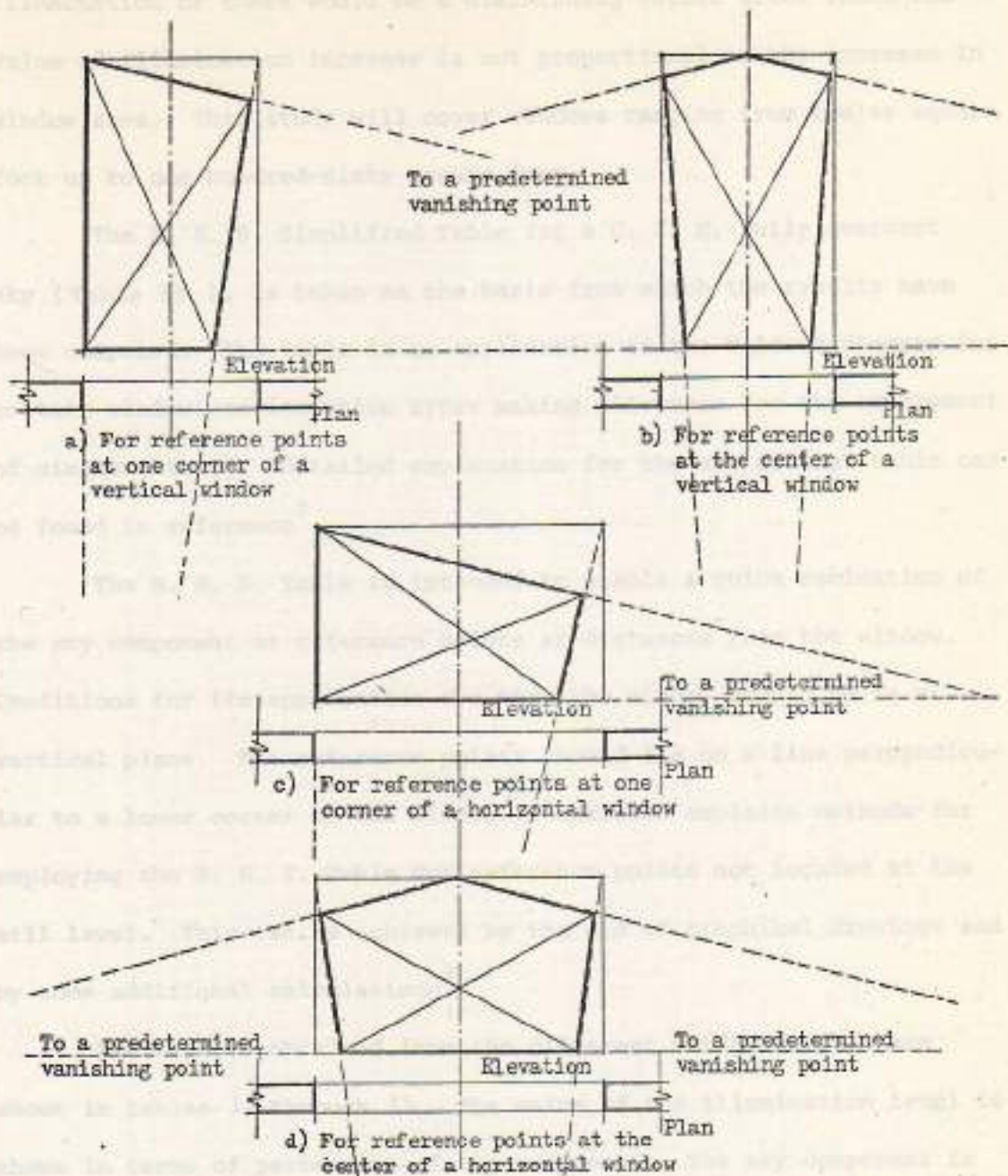

Fig 29 SKETCH DEMONSTRATING THE EQUIVALENT AREA OF EQUAL ILLUMINATION WITH RESPECT TO A REFERENCE POINT

illumination or there would be a diminishing return after which the value of illumination increase is not proportional to the increase in window area. This study will cover windows ranging from twelve square foot up to one hundred-sixty square feet.

The B. R. S. Simplified Table for a C. I. E. fully overcast sky (Table 13), is taken as the basis from which the results have been computed. The table is an application of the Waldram diagram for certain window configuration after making allowance for the employment of single glazing. Detailed explanation for the use of that table can be found in reference².

The B. R. S. Table is intended to enable a quick estimation of the sky component at reference points at distances from the window. Conditions for its application are that the window should be in a vertical plane. The reference points should lie on a line perpendicular to a lower corner of the window. Hopkinson explains methods for employing the B. R. S. Table for reference points not located at the sill level. This can be achieved by the aid of graphical drawings and by some additional calculations³.

The results obtained from the different window samples are shown in tables 14 through 15 . The value of the illumination level is shown in terms of percentage of sky component. The sky component is

²R. G. Hopkinson, P. Petherbridge, J. Longmore: Daylighting, Heinemann, London, 1963, pp. 110-124.

³Ibid., p. 116.

SKY COMPONENTS (C.I.E. STANDARD OVERCAST SKY) FOR VERTICAL GLAZED RECTANGULAR WINDOWS

Ratio H/D = Height of Window Head above Working Plane	Ratio W/D = Width of Window to one Side of Normal	Distance from Window	0	1	2	3	4	5	6	7	8	9	10	12	14	16	18	20	25	30	40	60	∞	Angle of Obstruction
0	0.1	0.2	0.3	0.4	0.5	0.6	0.7	0.8	0.9	1.0	1.2	1.4	1.6	1.8	2.0	2.5	3.0	4.0	6.0	10	15	30	60	
0.1	0.2	0.3	0.4	0.5	0.6	0.7	0.8	0.9	1.0	1.2	1.4	1.6	1.8	2.0	2.5	3.0	4.0	6.0	10	15	30	60		
0.2	0.3	0.4	0.5	0.6	0.7	0.8	0.9	1.0	1.2	1.4	1.6	1.8	2.0	2.5	3.0	4.0	6.0	10	15	30	60			
0.3	0.4	0.5	0.6	0.7	0.8	0.9	1.0	1.2	1.4	1.6	1.8	2.0	2.5	3.0	4.0	6.0	10	15	30	60				
0.4	0.5	0.6	0.7	0.8	0.9	1.0	1.2	1.4	1.6	1.8	2.0	2.5	3.0	4.0	6.0	10	15	30	60					
0.5	0.6	0.7	0.8	0.9	1.0	1.2	1.4	1.6	1.8	2.0	2.5	3.0	4.0	6.0	10	15	30	60						
0.6	0.7	0.8	0.9	1.0	1.2	1.4	1.6	1.8	2.0	2.5	3.0	4.0	6.0	10	15	30	60							
0.7	0.8	0.9	1.0	1.2	1.4	1.6	1.8	2.0	2.5	3.0	4.0	6.0	10	15	30	60								
0.8	0.9	1.0	1.2	1.4	1.6	1.8	2.0	2.5	3.0	4.0	6.0	10	15	30	60									
0.9	1.0	1.2	1.4	1.6	1.8	2.0	2.5	3.0	4.0	6.0	10	15	30	60										
1.0	1.2	1.4	1.6	1.8	2.0	2.5	3.0	4.0	6.0	10	15	30	60											
1.2	1.4	1.6	1.8	2.0	2.5	3.0	4.0	6.0	10	15	30	60												
1.4	1.6	1.8	2.0	2.5	3.0	4.0	6.0	10	15	30	60													
1.6	1.8	2.0	2.5	3.0	4.0	6.0	10	15	30	60														
1.8	2.0	2.5	3.0	4.0	6.0	10	15	30	60															
2.0	2.5	3.0	4.0	6.0	10	15	30	60																
2.2	2.5	3.0	4.0	6.0	10	15	30	60																
2.4	2.5	3.0	4.0	6.0	10	15	30	60																
2.6	2.5	3.0	4.0	6.0	10	15	30	60																
2.8	2.5	3.0	4.0	6.0	10	15	30	60																
3.0	2.5	3.0	4.0	6.0	10	15	30	60																
3.2	2.5	3.0	4.0	6.0	10	15	30	60																
3.4	2.5	3.0	4.0	6.0	10	15	30	60																
3.6	2.5	3.0	4.0	6.0	10	15	30	60																
3.8	2.5	3.0	4.0	6.0	10	15	30	60																
4.0	2.5	3.0	4.0	6.0	10	15	30	60																
4.2	2.5	3.0	4.0	6.0	10	15	30	60																
4.4	2.5	3.0	4.0	6.0	10	15	30	60																
4.6	2.5	3.0	4.0	6.0	10	15	30	60																
4.8	2.5	3.0	4.0	6.0	10	15	30	60																
5.0	2.5	3.0	4.0	6.0	10	15	30	60																
5.2	2.5	3.0	4.0	6.0	10	15	30	60																
5.4	2.5	3.0	4.0	6.0	10	15	30	60																
5.6	2.5	3.0	4.0	6.0	10	15	30	60																
5.8	2.5	3.0	4.0	6.0	10	15	30	60																
6.0	2.5	3.0	4.0	6.0	10	15	30	60																
6.2	2.5	3.0	4.0	6.0	10	15	30	60																
6.4	2.5	3.0	4.0	6.0	10	15	30	60																
6.6	2.5	3.0	4.0	6.0	10	15	30	60																
6.8	2.5	3.0	4.0	6.0	10	15	30	60																
7.0	2.5	3.0	4.0	6.0	10	15	30	60																
7.2	2.5	3.0	4.0	6.0	10	15	30	60																
7.4	2.5	3.0	4.0	6.0	10	15	30	60																
7.6	2.5	3.0	4.0	6.0	10	15	30	60																
7.8	2.5	3.0	4.0	6.0	10	15	30	60																
8.0	2.5	3.0	4.0	6.0	10	15	30	60																
8.2	2.5	3.0	4.0	6.0	10	15	30	60																
8.4	2.5	3.0	4.0	6.0	10	15	30	60																
8.6	2.5	3.0	4.0	6.0	10	15	30	60																
8.8	2.5	3.0	4.0	6.0	10	15	30	60																
9.0	2.5	3.0	4.0	6.0	10	15	30	60																
9.2	2.5	3.0	4.0	6.0	10	15	30	60																
9.4	2.5	3.0	4.0	6.0	10	15	30	60																
9.6	2.5	3.0	4.0	6.0	10	15	30	60																
9.8	2.5	3.0	4.0	6.0	10	15	30	60																
10.0	2.5	3.0	4.0	6.0	10	15	30	60																

Table 13 B. R. S. Simplified Table for a C. I. E. fully overcast sky.

Window size H x W (ft.)	Distance from Window (ft.) D	$\frac{H}{D}$	$\frac{W}{D}$	Sky Component S.C.%	Ratio $SC_1:SC_2:SC_3$
4 x 3 (12 ft ²)	1/3 x 10	1.20	0.90	4.8	1:.23:.07
	2/3 x 10	0.60	0.45	1.09	
	10	0.40	0.30	0.43	
3 x 4 (12 ft ²)	1/3 x 10	0.90	1.20	3.7	1:.21:.07
	2/3 x 10	0.45	0.60	0.79	
	10	0.30	0.40	0.26	
5 x 3 (15 ft ²)	1/3 x 11	1.36	0.82	5.14	1:.26:.08
	2/3 x 11	0.68	0.41	1.318	
	11	0.45	0.27	0.43	
3 x 5 (15 ft ²)	1/3 x 11	0.82	1.36	3.2	1:.22:.09
	2/3 x 11	0.41	0.68	0.70	
	11	0.27	0.45	0.28	
6 x 4 (24 ft ²)	1/3 x 13	1.39	0.92	5.6	1:.25:.08
	2/3 x 13	0.69	0.46	1.4	
	13	0.46	0.31	0.44	
4 x 6 (24 ft ²)	1/3 x 13	0.92	1.39	3.8	1:.22:.07
	2/3 x 13	0.46	0.68	0.85	
	13	0.31	0.46	0.28	
7 x 4 (28 ft ²)	5	1.40	0.80	5.2	1:.25:.08
	10	0.70	0.40	1.3	
	15	0.47	0.27	0.42	
4 x 7 (28 ft ²)	5	0.80	1.40	3.3	1:.22:.08
	10	0.40	0.70	0.70	
	15	0.27	0.47	0.26	
8 x 4 (32 ft ²)	5	1.60	0.80	5.8	1:.28:.09
	10	0.80	0.40	1.6	
	15	0.53	0.27	0.52	
4 x 8 (32 ft ²)	5	0.80	1.60	3.3	1:.23:.09
	10	0.40	0.80	0.75	
	15	0.27	0.53	0.3	

Comparison between the performances of rectangular windows having different proportions.

TABLE 14

Continued.

Window size H x W (ft)	Distance from Window (ft) D	H D	W D	Sky Component S.C. %	Ratio SC ₁ :SC ₂ :SC ₃
9 x 5 (45 ft ²)	1/3 x 16	1.69	0.94	6.6	1:.30:.10
	2/3 x 16	0.84	0.47	2.0	
	16	0.56	0.31	0.64	
5 x 9 (45 ft ²)	1/3 x 16	0.94	1.69	4.00	1:.23:.08
	2/3 x 16	0.47	0.84	0.90	
	16	0.31	0.56	0.32	
10 x 5 (50 ft ²)	6	1.67	0.83	6.0	1:.28:.10
	12	0.83	0.42	1.70	
	18	0.56	0.28	0.62	
5 x 10 (50 ft ²)	6	0.83	1.67	3.3	1:.25:.10
	12	0.42	0.83	0.83	
	18	0.28	0.56	0.32	
10 x 6 (60 ft ²)	6	1.67	1.00	6.7	1:.30:.10
	12	0.83	0.50	2.0	
	18	0.56	0.33	0.64	
6 x 10 (60 ft ²)	6	1.00	1.67	4.6	1:.25:.08
	12	0.50	0.83	1.13	
	18	0.33	0.56	0.36	
10 x 7 (70 ft ²)	6	1.67	1.17	7.3	1:.29:.11
	12	0.83	0.58	2.1	
	18	0.56	0.39	0.79	
7 x 10 (70 ft ²)	6	1.17	1.67	5.9	1:.23:.10
	12	0.58	0.83	1.35	
	18	0.39	0.56	0.59	
10 x 8 (80 ft ²)	6	1.67	1.33	7.4	1:.34:.12
	12	0.83	0.67	2.5	
	18	0.56	0.44	0.86	
8 x 10 (80 ft ²)	6	1.33	1.67	6.5	1:.23:.11
	12	0.67	0.83	1.5	
	18	0.44	0.56	0.69	
11 x 4 (44 ft ²)	6	1.83	0.67	5.85	1:.29:.10
	12	0.92	0.33	1.7	
	18	0.61	0.22	0.57	
4 x 11 (44 ft ²)	6	0.67	1.83	2.4	1:.23:.07
	12	0.33	0.92	0.54	
	18	0.22	0.61	0.16	

Continued.

Window size H x W (ft)	Distance from Window (ft) D	$\frac{H}{D}$	$\frac{W}{D}$	Sky Component S.C.%	Ratio $SC_1:SC_2:SC_3$
11 x 5 (55 ft ²)	6	1.83	0.83	6.4	1:.31:.11
	12	0.92	0.42	2.0	
	18	0.61	0.28	0.69	
5 x 11 (55 ft ²)	6	0.83	1.83	3.5	1:.24:.06
	12	0.42	0.92	0.83	
	18	0.28	0.61	0.22	
12 x 6 (72 ft ²)	1/3 x 19	1.9	0.95	7.1	1:.30:.12
	2/3 x 19	0.95	0.47	2.15	
	19	0.63	0.32	0.85	
6 x 12 (72 ft ²)	1/3 x 19	0.95	1.9	4.35	1:.21:.09
	2/3 x 19	0.47	0.95	0.90	
	19	0.32	0.63	0.40	
12 x 7 (84 ft ²)	1/3 x 20	1.80	1.05	7.15	1:.32:.12
	2/3 x 20	0.90	0.53	2.32	
	20	0.60	0.35	0.86	
7 x 12 (84 ft ²)	1/3 x 20	1.05	1.80	5.0	1:.27:.12
	2/3 x 20	0.53	0.90	1.35	
	20	0.35	0.60	0.58	
12 x 7 (84 ft ²)	7	1.71	1.0	6.83	1:.30:.09
	14	0.86	0.50	2.08	
	21	0.57	0.33	0.624	
7 x 12 (84 ft ²)	7	1.0	1.71	4.65	1:.25:.09
	14	0.50	0.86	1.16	
	21	0.33	0.57	0.398	
12 x 8 (96 ft ²)	7	1.71	1.14	7.27	1:.31:.10
	14	0.86	0.57	2.27	
	21	0.57	0.38	0.748	
8 x 12 (96 ft ²)	7	1.14	1.71	5.55	1:.27:.08
	14	0.57	0.86	1.51	
	21	0.38	0.57	0.447	
12 x 9 (108 ft ²)	7	1.71	1.29	7.68	1:.33:.12
	14	0.86	0.64	2.52	
	21	0.57	0.43	0.932	
9 x 12 (108 ft ²)	7	1.29	1.71	6.5	1:.29:.10
	14	0.64	0.86	1.86	
	21	0.43	0.57	0.68	

Continued.

Window size H x W (ft)	Distance from Window (ft) D	$\frac{H}{D}$	$\frac{W}{D}$	Sky Component S.C. %	Ratio $SC_1:SC_2:SC_3$
13 x 7 (91 ft ²)	5	2.60	1.40	9.8	1:.46:.21
	10	1.30	0.70	4.5	
	15	0.87	0.47	2.02	
7 x 13 (91 ft ²)	5	1.40	2.60	7.42	1:.34:.13
	10	0.70	1.30	2.50	
	15	0.47	0.87	0.969	
13 x 7 (91 ft ²)	6	2.17	1.17	8.52	1:.35:.15
	12	1.08	0.58	2.952	
	18	0.72	0.39	1.303	
7 x 13 (91 ft ²)	6	1.17	2.17	5.599	1:.31:.12
	12	0.58	1.08	1.74	
	18	0.39	0.72	0.676	
13 x 8 (101 ft ²)	7	1.86	1.14	7.71	1:.34:.13
	14	0.93	0.57	2.6	
	21	0.62	0.38	0.978	
8 x 13 (101 ft ²)	7	1.14	1.86	5.484	1:.27:.12
	14	0.57	0.93	1.48	
	21	0.38	0.62	0.648	
13 x 9 (117 ft ²)	7	1.86	1.29	8.34	1:.34:.13
	14	0.93	0.64	2.8	
	21	0.62	0.43	1.108	
9 x 13 (117 ft ²)	7	1.29	1.86	6.57	1:.29:.13
	14	0.64	0.93	1.93	
	21	0.43	0.62	0.885	
14 x 7 (98 ft ²)	5	2.80	1.40	10.0	1:.48:.21
	10	1.40	0.70	4.8	
	15	0.93	0.47	2.11	
7 x 14 (98 ft ²)	5	1.40	2.80	7.44	1:.34:.15
	10	0.70	1.40	2.5	
	15	0.47	0.93	1.107	
14 x 8 (112 ft ²)	6	2.33	1.33	8.987	1:.43:.18
	12	1.17	0.67	3.89	
	18	0.78	0.44	1.62	
8 x 14 (112 ft ²)	6	1.33	2.33	6.914	1:.31:.12
	12	0.67	1.17	2.167	
	21	0.44	0.78	0.8	

Continued.

Continued, TABLE 14

Window size H x W (ft)	Distance from Window (ft) D	$\frac{H}{D}$	$\frac{W}{D}$	Sky Component S.C. %	Ratio SC ₁ :SC ₂ :SC ₃
14 x 9 (126 ft ²)	7	2.00	1.29	8.48	1: .37: .14
	14	1.00	0.64	3.12	
	21	0.67	0.43	1.192	
9 x 14 (126 ft ²)	7	1.29	2.00	6.54	1: .31: .12
	14	0.64	1.00	2.00	
	21	0.43	0.67	0.781	
14 x 10 (140 ft ²)	7	2.00	1.43	8.76	1: .38: .16
	14	1.00	0.71	3.33	
	21	0.67	0.48	1.38	
10 x 14 (140 ft ²)	7	1.43	2.00	7.45	1: .32: .13
	14	0.71	1.00	2.36	
	21	0.48	0.67	0.956	
15 x 7 (105 ft ²)	6	2.50	1.17	9.10	1: .38: .18
	12	1.25	0.58	3.49	
	18	0.83	0.39	1.65	
7 x 15 (105 ft ²)	6	1.17	2.50	5.85	1: .31: .12
	12	0.58	1.25	1.8	
	18	0.39	0.83	0.723	
15 x 8 (120 ft ²)	7	2.14	1.14	8.424	1: .37: .15
	14	1.07	0.57	3.09	
	21	0.71	0.38	1.257	
8 x 15 (120 ft ²)	7	1.14	2.14	5.498	1: .31: .12
	14	0.57	1.07	1.685	
	21	0.38	0.71	0.636	
15 x 10 (150 ft ²)	7	2.14	1.43	8.788	1: .42: .17
	14	1.07	0.71	3.68	
	21	0.71	0.48	1.49	
10 x 15 (150 ft ²)	7	1.43	2.14	7.475	1: .33: .10
	14	0.71	1.07	2.43	
	21	0.48	0.71	0.729	
16 x 8 (128 ft ²)	6	2.67	1.33	9.835	1: .45: .20
	12	1.33	0.67	4.47	
	18	0.89	0.44	1.99	
8 x 16 (128 ft ²)	6	1.33	2.67	7.00	1: .30: .13
	12	0.67	1.33	2.08	
	18	0.44	0.89	0.903	

Continued.

Continued. TABLE 14

Window size H x W (ft)	Distance from Window (ft) D	$\frac{H}{D}$	$\frac{W}{D}$	Sky Component S.C. %	Ratio $SC_1:SC_2:SC_3$
16 x 9 (144 ft ²)	6	2.67	1.50	10.12	1:.47:.21
	12	1.33	0.75	4.79	
	18	0.89	0.50	2.17	
9 x 16 (144 ft ²)	6	1.50	2.67	7.967	1:.34:.15
	12	0.75	1.33	2.68	
	18	0.50	0.89	1.19	
16 x 10 (160 ft ²)	7	2.29	1.43	9.24	1:.43:.18
	14	1.14	0.71	3.99	
	21	0.76	0.48	1.64	
10 x 16 (160 ft ²)	7	1.43	2.29	6.68	1:.37:.15
	14	0.71	1.14	2.5	
	21	1.64	0.76	0.97	

Comparison between the performances of rectangular windows having different proportions.

16 x 9	6	2.67	1.50	10.12	1:.47:.21
16 x 9	12	1.33	0.75	4.79	
16 x 9	18	0.89	0.50	2.17	
(144 ft ²)	6	1.50	2.67	7.967	1:.34:.15
(144 ft ²)	12	0.75	1.33	2.68	
(144 ft ²)	18	0.50	0.89	1.19	
16 x 10	7	2.29	1.43	9.24	1:.43:.18
16 x 10	14	1.14	0.71	3.99	
16 x 10	21	0.76	0.48	1.64	
(160 ft ²)	7	1.43	2.29	6.68	1:.37:.15
(160 ft ²)	14	0.71	1.14	2.5	
(160 ft ²)	21	1.64	0.76	0.97	

Performance of square window having aspect equivalent to the rectangular window treated previously in Table 14.

ft. - equivalent to window size

TABLE 15

Continued.

Window size H x W ft.	Distance from Window ft., D	$\frac{H}{D}$	$\frac{W}{D}$	Sky Component S.C.%	Ratio $SC_1:SC_2:SC_3$
(3.46) ² Eq.W.** 4 x 3	1/3 x 10	1.04	1.04	4.3	1:.22:.07
	2/3 x 10	0.52	0.52	0.926	
	10	0.35	0.35	0.30	
(3.87) ² Eq.W. 5 x 3	1/3 x 11	1.05	1.05	4.375	1:.22:.07
	2/3 x 11	0.53	0.53	0.979	
	11	0.35	0.35	0.30	
(4.90) ² Eq.W. 6 x 4	1/3 x 13	1.13	1.13	4.873	1:.24:.08
	2/3 x 13	0.57	0.57	1.191	
	13	0.38	0.38	0.382	
(5.29) ² Eq.W. 7 x 4	5	1.06	1.06	4.126	1:.26:.07
	10	0.53	0.53	0.979	
	15	0.35	0.35	0.30	
(5.66) ² Eq.W. 8 x 4	5	1.13	1.13	4.837	1:.26:.08
	10	0.57	0.57	1.191	
	15	0.38	0.38	0.382	
(6.71) ² Eq.W. 9 x 5	1/3 x 16	1.26	1.26	5.79	1:.26:.09
	2/3 x 16	0.63	0.63	1.48	
	16	0.42	0.42	0.518	
(7.07) ² Eq.W. 10 x 5	6	1.18	1.18	5.2	1:.25:.08
	12	0.59	0.59	1.297	
	18	0.39	0.39	0.396	
(7.75) ² Eq.W. 10 x 6	6	1.29	1.29	6.0	1:.27:.09
	12	0.65	0.65	1.6	
	18	0.43	0.43	0.552	
(8.37) ² Eq.W. 10 x 7	6	1.40	1.40	6.70	1:.28:.10
	12	0.70	0.70	1.90	
	18	0.47	0.47	0.688	
(8.94) ² Eq.W. 10 x 8	6	1.49	1.49	7.195	1:.31:.11
	12	0.75	0.75	2.35	
	18	0.50	0.50	0.82	

Performances of square windows having areas equivalent to the rectangular windows tested previously in Table 14.

** - Equivalent to window size

TABLE 15

Continued.

Continued.

TABLE 15

Window size H x W ft.	Distance from Window ft. D	$\frac{H}{D}$	$\frac{W}{D}$	Sky Component S.C. %	Ratio SC ₁ :SC ₂ :SC ₃
(6.63) ² Eq.W. 11 x 4	6	1.11	1.11	4.795	1:.23:.07
	12	0.70	0.70	1.90	
	18	0.47	0.47	0.688	
(7.42) ² Eq.W. 11 x 5	6	1.24	1.24	5.66	1:.25:.08
	12	0.62	0.62	1.42	
	18	0.41	0.41	0.4615	
(8.49) ² Eq.W. 12 x 6	1/3 x 19	1.34	1.34	6.31	1:.27:.10
	2/3 x 19	0.67	0.67	1.72	
	19	0.45	0.45	0.62	
(9.17) ² Eq.W. 12 x 7	1/3 x 20	1.37	1.37	6.505	1:.27:.10
	2/3 x 20	0.69	0.69	1.75	
	20	0.46	0.46	0.654	
(9.17) ² Eq.W. 12 x 7	7	1.31	1.31	6.07	1:.27:.10
	14	0.66	0.66	1.66	
	21	0.44	0.44	0.586	
(9.8) ² Eq.W. 12 x 8	7	1.40	1.40	6.70	1:.28:.10
	14	0.70	0.70	1.90	
	21	0.47	0.47	0.688	
(10.39) ² Eq.W. 12 x 9	7	1.48	1.48	7.14	1:.31:.11
	14	0.74	0.74	2.18	
	21	0.49	0.49	0.756	
(9.54) ² Eq.W. 13 x 7	6	1.59	1.59	7.745	1:.34:.13
	12	0.80	0.80	2.60	
	18	0.53	0.53	0.979	
(9.54) ² Eq.W. 13 x 7	5	1.91	1.91	9.34	1:.36:.16
	10	0.95	0.95	3.375	
	15	0.64	0.64	1.54	
(10.20) ² Eq.W. 13 x 8	7	1.46	1.46	7.03	1:.30:.11
	14	0.73	0.73	2.11	
	21	0.49	0.49	0.756	
(10.82) ² Eq.W. 13 x 9	7	1.55	1.55	7.45	1:.32:.12
	14	0.77	0.77	2.39	
	21	0.52	0.52	0.926	
(9.90) ² Eq.W. 14 x 7	5	1.98	1.98	9.66	1:.40:.17
	10	0.99	0.99	3.84	
	15	0.66	0.66	1.66	

Continued.

Continued. TABLE 15

Window size H x W ft.	Distance from Window ft. D	$\frac{H}{D}$	$\frac{W}{D}$	Sky Component S.C.-A	Ratio $SC_1:SC_2:SC_3$
(10.58) ²	6	1.76	1.76	8.75	1:.35:.15
Eq.W.	12	0.88	0.88	3.08	
14 x 8	18	0.59	0.59	1.297	
(11.22) ²	7	1.60	1.60	7.80	1:.33:.13
Eq.W.	14	0.80	0.80	2.60	
14 x 9	21	0.53	0.53	0.979	
(11.83) ²	7	1.69	1.69	8.295	1:.35:.14
Eq.W.	14	0.85	0.85	2.90	
14 x 10	21	0.56	0.56	1.138	
(10.25) ²	6	1.71	1.71	8.395	1:.35:.16
Eq.W.	12	0.85	0.85	2.90	
15 x 7	18	0.57	0.57	1.191	
(10.95) ²	7	1.56	1.56	7.69	1:.33:.12
Eq.W.	14	0.78	0.78	2.50	
15 x 8	21	0.52	0.52	0.922	
(12.25) ²	7	1.75	1.75	8.575	1:.36:.15
Eq.W.	14	0.88	0.88	3.08	
15 x 10	21	0.58	0.58	1.244	
(11.31) ²	6	1.89	1.89	9.34	1:.38:.16
Eq.W.	12	0.94	0.94	3.54	
16 x 8	18	0.63	0.63	1.48	
(12) ²	6	2.00	2.00	9.70	1:.41:.18
Eq.W.	12	1.00	1.00	4.00	
16 x 9	18	0.67	0.67	1.72	
(12.65) ²	7	1.81	1.81	8.85	1:.37:.15
Eq.W.	14	0.90	0.90	3.30	
16 x 10	21	0.60	0.60	1.30	

Performances of square windows having areas equivalent to the rectangular windows tested previously in Table 14.

the usual measure of the direct sunlight under a non-uniform sky⁴. Direct sunlight is not included in the values of illumination shown in these tables.

It is evident from the shown tables that for a given window area, the illumination changes with a change in the window's proportions. This comparison is further elaborated upon in tables 18 through 19. In these tables, windows are clustered in groups with similar areas. Each group contains the three different types of windows - the vertical, the horizontal, and the square window. Therefore, though the windows in each group are equivalent in area, they differ in their proportions. For example, a tall window 10 ft. by 5 ft., has the proportion of 1:0.5 for height to width, whereas the same window when positioned horizontally, will have a ratio of 1:2. The same area of window, when made square, will have a ratio of 1:1, and so on. When the given tables are carefully examined, it will be realized that for a given area, the tall window always is superior in performance than the other shapes of windows in the same group. When maximum light and quality are the goals sought, the taller the window, the more light the reference point will receive and the better the resulting quality will be. It will be maintained that if the distribution of light across the room is higher than the initially proposed minimum standard, this will be an indication of good quality. In examining this further, let us compare two groups

⁴Ibid., pp. 70 and 578.

of windows from among those listed on the table that represents the extremes in the study. The first group consists of two windows which are 7 ft. by 4 ft. and 4 ft. by 7 ft. (height by width). The second group consists of windows which are 10 ft. by 8 ft. and 8 ft. by 10 ft. Within the first group, the sky component of the daylight factor at a reference point 5 feet from the left corner of the window is 5.2 percent for the vertical window, while for the horizontal window it is only 3.2 percent. This means that the vertical window gave 62.5 percent more illumination than the horizontal one of the same glazing area.

If the window of the second group is examined following the same rules, we shall see that the vertical window in that group, which is 10 ft. by 8 ft., gives only a 5.8 percent increase and not a 62.5 percent as the former window of the first group. The reason for this is that the difference in proportion of length to width in the 10 ft. by 8 ft. window is not great enough between the horizontal and vertical window to have a significant influence on the amount of light as found in the differences of the first group.

It is evident that the window proportion plays a more important role than the total area of the window in determining the window performance in producing the maximum light.

Since in the library reading rooms the furniture is almost permanent in its location, the position of windows and their proportions may contribute much to the illumination on the reading plane.

In examining light distribution, the efficiency of windows were studied for their ability to maintain light penetration without serious decreases.

Tests have been made for reference points located at distances of 5, 10, and 15 feet from the window corner. Tables 16 through 17 show the outcome of the results and the manner in which each window distributes the light, whether quantitatively or qualitatively.

The conclusion drawn from this examination reveals the superiority of the vertical window over both the horizontal and the square windows, both in terms of the quantity and the quality of light penetrating the interior.

It can be shown, however, that one can obtain double the amount of light by a wise choice of window proportions. To demonstrate this, let us take a window of 4 ft. by 7 ft., though any other window would serve as well.

As we have seen before, the long window, 4 ft. by 7 ft., introduces a 3.2 percent sky component at a distance of 5 feet from the window corner. Splitting this window into two horizontal strips of 2 ft. by 7 ft. each, and positioning one of these window halves vertically so that the long side (7 ft.) becomes its height, the sky component obtained at the same reference point was found to be 3.2 percent. This means that the reference point received the same amount of light after reducing the window area by 50 percent.

By positioning the other window half beside the vertical one, the sky component at the mentioned reference point was found to be 5.2 percent and not double 3.2 percent (that is, 6.4 percent). This means that the 7 ft. by 2 ft. window nearest the reference point introduced 3.2 percent S.C., while the adjacent 7 ft. by 2 ft. window introduced only 2 percent S.C.

Window size H x W ft.	Distance from Window ft. D	$\frac{H}{D}$	$\frac{W}{D}$	Sky Component S.C.†	Ratio SC ₁ :SC ₂ :SC ₃
(3.46) ² Eq. W. 4 x 3	5	0.69	0.69	1.86	1:.16:.05
	10	0.35	0.35	0.30	
	15	0.23	0.23	0.093	
(3.87) ² Eq. W. 5 x 3	5	0.77	0.77	2.39	1:.17:.05
	10	0.39	0.39	0.396	
	15	0.26	0.26	0.126	
(4.90) ² Eq. W. 6 x 4	5	0.98	0.98	0.98	1:.23:.08
	10	0.49	0.49	0.49	
	15	0.33	0.33	0.33	
(5.29) ² Eq. W. 7 x 4	5	1.06	1.06	4.45	1:.22:.07
	10	0.53	0.53	0.979	
	15	0.35	0.35	0.30	
(5.66) ² Eq. W. 8 x 4	5	1.13	1.13	4.915	1:.24:.08
	10	0.57	0.57	1.191	
	15	0.38	0.38	0.372	
(6.71) ² Eq. W. 9 x 5	5	1.34	1.34	6.27	1:.27:.10
	10	0.67	0.67	1.72	
	15	0.45	0.45	0.620	
(7.07) ² Eq. W. 10 x 5	5	1.41	1.41	6.719	1:.29:.10
	10	0.71	0.71	1.97	
	15	0.47	0.47	0.681	
(7.75) ² Eq. W. 10 x 6	5	1.55	1.55	7.525	1:.33:.12
	10	0.78	0.78	2.46	
	15	0.52	0.52	0.926	
(8.37) ² Eq. W. 10 x 7	5	1.67	1.67	8.185	1:.35:.14
	10	0.84	0.84	2.84	
	15	0.56	0.56	1.138	
(8.94) ² Eq. W. 10 x 8	5	1.79	1.79	8.755	1:.36:.15
	10	0.89	0.89	3.14	
	15	0.60	0.60	1.3	

Influence of the square windows' areas increase upon the distribution of light at reference points 5, 10, and 15 feet from the window corner.

TABLE 16

Continued.

Continued. TABLE 16

Window size H x W ft.	Distance from Window ft. D	$\frac{H}{D}$	$\frac{W}{D}$	Sky Component S.C. %	Ratio $SC_1:SC_2:SC_3$
(6.63) ² Eq. W. 11 x 4	5	1.33	1.33	6.245	1:.24:.09
	10	0.66	0.66	1.52	
	15	0.44	0.44	0.586	
(7.42) ² Eq. W. 11 x 5	5	1.48	1.48	7.022	1:.32:.11
	10	0.74	0.74	2.22	
	15	0.49	0.49	0.756	
(8.49) ² Eq. W. 12 x 6	5	1.70	1.70	8.35	1:.35:.14
	10	0.85	0.85	2.90	
	15	0.57	0.57	1.191	
(9.17) ² Eq. W. 12 x 7	5	1.83	1.83	8.95	1:.38:.15
	10	0.92	0.92	3.42	
	15	0.61	0.61	1.36	
(9.8) ² Eq. W. 12 x 8	5	1.96	1.96	9.62	1:.35:.17
	10	0.98	0.98	3.34	
	15	0.65	0.65	1.60	
(10.39) ² Eq. W. 12 x 9	5	2.08	2.08	9.743	1:.44:.19
	10	1.04	1.04	4.30	
	15	0.69	0.69	1.84	
(9.54) ² Eq. W. 13 x 7	5	1.91	1.91	9.395	1:.38:.16
	10	0.95	0.95	3.6	
	15	0.64	0.64	1.54	
(10.2) ² Eq. W. 13 x 8	5	2.04	2.04	9.736	1:.43:.18
	10	1.02	1.02	4.18	
	15	0.68	0.68	1.78	
(10.82) ² Eq. W. 13 x 9	5	2.16	2.16	10.135	1:.45:.20
	10	1.08	1.08	4.60	
	15	0.72	0.72	2.04	
(9.90) ² Eq. W. 14 x 7	5	1.98	1.98	9.62	1:.40:.16
	10	0.99	0.99	3.84	
	15	0.66	0.66	1.52	
(10.58) ² Eq. W. 14 x 8	5	2.12	2.12	10.003	1:.44:.20
	10	1.06	1.06	4.45	
	15	0.71	0.71	1.97	

Influence of the square windows' areas increase upon the distribution of light at reference points 5, 10, and 15 feet from the window corner.

Continued.

Continued. TABLE 16

Window size H x W ft.	Distance from Window ft. D	$\frac{H}{D}$	$\frac{W}{D}$	Sky Component S.C.%	Ratio $SC_1:SC_2:SC_3$
(11.22) ² Eq. W. 14 x 9	5	2.24	2.24	10.544	1:.46:.21
	10	1.12	1.12	4.86	
	15	0.75	0.75	2.25	
(11.83) ² Eq. W. 14 x 10	5	2.37	2.39	10.847	1:.46:.23
	10	1.18	1.18	5.04	
	15	0.79	0.79	2.53	
(10.25) ² Eq. W. 15 x 7	5	2.05	2.05	9.845	1:.43:.18
	10	1.03	1.03	4.225	
	15	0.68	0.68	1.78	
(10.95) ² Eq. W. 15 x 8	5	2.20	2.20	10.32	1:.46:.20
	10	1.10	1.10	4.75	
	15	0.73	0.73	2.11	
(12.25) ² Eq. W. 15 x 10	5	2.45	2.45	11.17	1:.50:.24
	10	1.23	1.23	5.595	
	15	0.82	0.82	2.72	
(11.31) ² Eq. W. 16 x 8	5	2.26	2.26	10.656	1:.46:.21
	10	1.13	1.13	4.915	
	15	0.75	0.75	2.25	
(12) ² Eq. W. 16 x 9	5	2.40	2.40	10.94	1:.49:.24
	10	1.20	1.20	5.40	
	15	0.80	0.80	2.60	
(12.65) ² Eq. W. 16 x 10	5	2.53	2.53	11.38	1:.51:.25
	10	1.27	1.27	5.855	
	15	0.84	0.84	2.84	

Influence of the square windows' areas increase upon the distribution of light at reference points 5, 10, and 15 feet away from the window corner.

5	2.24	2.24	10.544	1:.46:.21
10	1.12	1.12	4.86	
15	0.75	0.75	2.25	

Effect of the window size and proportion upon the distribution of light at reference points 5, 10, and 15 feet from the window corner.

Window size H. x W ft.	Distance from Window ft. D	$\frac{H}{D}$	$\frac{W}{D}$	Sky Component S.C. %	Ratio $SC_1:SC_2:SC_3$
4 x 3	5	0.80	0.60	2.2	1:.15:.05
	10	0.40	0.30	0.34	
	15	0.27	0.20	0.116	
3 x 4	5	0.60	0.80	1.6	1:.16:.05
	10	0.30	0.40	0.26	
	15	0.20	0.27	0.08	
5 x 3	5	1.00	0.60	3.0	1:.17:.06
	10	0.50	0.30	0.52	
	15	0.33	0.20	0.173	
3 x 5	5	0.60	1.00	1.8	1:.17:.07
	10	0.30	0.50	0.30	
	15	0.20	0.33	0.123	
6 x 4	5	1.20	0.80	4.5	1:.22:.07
	10	0.60	0.40	0.98	
	15	0.40	0.27	0.313	
4 x 6	5	0.80	1.20	3.1	1:.20:.07
	10	0.40	0.60	0.62	
	15	0.27	0.40	0.215	
7 x 4	5	1.40	0.80	5.2	1:.25:.08
	10	0.70	0.40	1.3	
	15	0.47	0.27	0.411	
4 x 7	5	0.80	1.40	3.2	1:.22:.07
	10	0.40	0.70	0.70	
	15	0.27	0.47	0.225	
8 x 4	5	1.60	0.80	5.8	1:.28:.09
	10	0.80	0.40	1.6	
	15	0.53	0.27	0.523	
4 x 8	5	0.80	1.60	3.3	1:.23:.08
	10	0.40	0.80	0.75	
	15	0.27	0.53	0.252	

Effect of the window size and proportion upon the distribution of light at reference points 5, 10, and 15 feet from the window corner.

TABLE 17

Continued.

Window size H x W ft.	Distance from Window ft. D	$\frac{H}{D}$	$\frac{W}{D}$	Sky Component S.C.%	Ratio SC ₁ :SC ₂ :SC ₃
9 x 5	5	1.80	1.00	7.1	1:.31:.11
	10	0.90	0.50	2.2	
	15	0.60	0.33	0.812	
5 x 9	5	1.00	1.80	3.6	1:.33:.12
	10	0.50	0.90	1.2	
	15	0.33	0.60	0.424	
10 x 5	5	2.00	1.00	7.5	1:.35:.13
	10	1.00	0.50	2.6	
	15	0.67	0.33	0.973	
5 x 10	5	1.00	2.00	4.7	1:.28:.09
	10	0.50	1.00	1.3	
	15	0.33	0.67	0.425	
10 x 6	5	2.00	1.20	8.3	1:.36:.13
	10	1.00	0.60	3.0	
	15	0.67	0.40	1.104	
6 x 10	5	1.20	2.00	6.1	1:.30:.11
	10	0.60	1.00	1.8	
	15	0.40	0.67	0.676	
10 x 7	5	2.00	1.40	8.7	1:.38:.16
	10	1.00	0.70	3.3	
	15	0.67	0.47	1.358	
7 x 10	5	1.40	2.00	7.3	1:.32:.13
	10	0.70	1.00	2.3	
	15	0.47	0.67	0.921	
10 x 8	5	2.00	1.60	9.1	1:.40:.14
	10	1.00	0.80	3.6	
	15	0.67	0.53	1.251	
8 x 10	5	1.60	2.00	8.6	1:.34:.13
	10	0.80	1.00	2.9	
	15	0.53	0.67	1.09	
11 x 4	5	2.20	0.80	7.0	1:.36:.13
	10	1.10	0.40	2.5	
	15	0.73	0.27	0.90	
4 x 11	5	0.80	2.20	3.3	1:.27:.10
	10	0.40	1.10	0.905	
	15	0.73	0.33	1.138	

Continued.

Continued. TABLE 17

Window size. H x W ft.	Distance from Window ft D	$\frac{H}{D}$	$\frac{W}{D}$	Sky Component S.C. %	Ratio SC ₁ :SC ₂ :SC ₃
11 x 5	5	2.20	1.00	7.9	1:.38:.14
	10	1.10	0.50	3.0	
	15	0.73	0.33	1.138	
5 x 11	5	1.00	2.20	4.74	1:.28:.10
	10	0.50	1.10	1.35	
	15	0.33	0.73	0.488	
12 x 6	5	2.40	1.20	9.1	1:.42:.18
	10	1.20	0.60	3.8	
	15	0.80	0.40	1.6	
6 x 12	5	1.20	2.40	6.18	1:.31:.12
	10	0.60	1.20	1.9	
	15	0.40	0.80	0.75	
12 x 7	5	2.40	1.40	7.5	1:.44:.19
	10	1.20	0.70	4.2	
	15	0.80	0.47	1.81	
7 x 12	5	1.40	2.40	7.38	1:.34:.12
	10	0.70	1.20	2.5	
	15	0.47	0.80	0.995	
12 x 8	5	2.40	1.60	10.0	1:.45:.20
	10	1.20	0.80	4.5	
	15	0.80	0.53	1.99	
8 x 12	5	1.60	2.40	8.36	1:.37:.15
	10	0.80	1.20	3.10	
	15	0.53	0.80	1.25	
12 x 9	5	2.40	1.80	10.4	1:.46:.21
	10	1.20	0.90	4.8	
	15	0.80	0.60	2.2	
9 x 12	5	1.80	2.40	9.16	1:.40:.17
	10	0.90	1.20	3.7	
	15	0.60	0.80	1.6	
13 x 7	5	2.60	1.40	9.8	1:.46:.21
	10	1.30	0.70	4.5	
	15	0.87	0.47	2.02	
7 x 13	5	1.40	2.60	7.42	1:.34:.14
	10	0.70	1.30	2.50	
	15	0.47	0.87	1.044	

Continued.

Window size H. x W. ft.	Distance from Window ft., D	$\frac{H}{D}$	$\frac{W}{D}$	Sky Component S.C. %	Ratio SC ₁ :SC ₂ :SC ₃
13 x 8	5	2.60	1.60	10.20	1:.48:.22
	10	1.30	0.80	4.9	
	15	0.87	0.53	2.0	
8 x 13	5	1.60	2.60	7.92	1:.40:.17
	10	0.80	1.30	3.15	
	15	0.53	0.87	1.32	
13 x 9	5	2.60	1.80	10.8	1:.48:.22
	10	1.30	0.90	5.2	
	15	0.87	0.60	2.48	
9 x 13	5	1.80	2.60	9.22	1:.41:.18
	10	0.90	1.30	3.75	
	15	0.60	0.87	1.67	
14 x 7	5	2.80	1.40	10.0	1:.48:.22
	10	1.40	0.70	4.8	
	15	0.93	0.47	2.2	
7 x 14	5	1.40	2.80	7.48	1:.33:.16
	10	0.70	1.40	2.5	
	15	0.47	0.93	1.167	
14 x 8	5	2.80	1.60	10.5	1:.48:.22
	10	1.40	0.80	5.2	
	15	0.93	0.53	2.44	
8 x 14	5	1.60	2.80	8.48	1:.38:.16
	10	0.80	1.40	3.2	
	15	0.53	0.93	1.38	
14 x 9	5	2.80	1.80	11.1	1:.50:.23
	10	1.40	0.90	5.6	
	15	0.93	0.60	2.72	
9 x 14	5	1.80	2.80	9.28	1:.38:.16
	10	0.90	1.40	3.8	
	15	0.60	0.93	1.73	
14 x 10	5	2.80	2.00	11.4	1:.52:.25
	10	1.40	1.00	5.9	
	15	0.93	0.67	2.86	
10 x 14	5	2.00	2.80	9.98	1:.45:.21
	10	1.00	1.40	4.50	
	15	0.67	0.93	2.08	

Continued.

Window size H x W ft.	Distance from Window ft. D	$\frac{H}{D}$	$\frac{W}{D}$	Sky Component S.C. %	Ratio $SC_1:SC_2:SC_3$
15 x 7	5	3.00	1.40	10.2	1:.50:.24
	10	1.50	0.70	5.1	
	15	1.00	0.47	2.48	
7 x 15	5	1.40	3.00	7.5	1:.34:.16
	10	0.70	1.50	2.55	
	15	0.47	1.00	1.177	
15 x 8	5	3.00	1.60	10.7	1:.52:.25
	10	1.50	0.80	5.6	
	15	1.00	0.53	2.72	
8 x 15	5	1.60	3.00	8.5	1:.38:.17
	10	0.80	1.50	3.25	
	15	0.53	1.00	1.45	
15 x 10	5	3.00	2.00	11.7	1:.53:.27
	10	1.50	1.00	6.2	
	15	1.00	0.67	3.21	
10 x 15	5	2.00	3.00	10.0	1:.46:.22
	10	1.00	1.50	4.55	
	15	0.67	1.00	2.15	
16 x 8	5	3.20	1.60	10.86	1:.53:.28
	10	1.60	0.80	5.8	
	15	1.07	0.53	3.0	
8 x 16	5	1.60	3.20	8.52	1:.39:.18
	10	0.80	1.60	3.3	
	15	0.53	1.07	1.52	
16 x 9	5	3.20	1.80	11.4	1:.54:.29
	10	1.60	0.90	6.2	
	15	1.07	0.60	3.28	
9 x 16	5	1.80	3.20	9.32	1:.42:.20
	10	0.90	1.60	3.9	
	15	0.60	1.07	1.835	

Continued.

Window size H x W ft.	Distance from Window ft., D	$\frac{H}{D}$	$\frac{W}{D}$	Sky Component S.C.%	Ratio SC ₁ :SC ₂ :SC ₃
16 x 10	5	3.20	2.00	11.8	1:.54:.29
	10	1.60	1.00	6.5	
	15	1.07	0.67	3.28	
10 x 16	5	2.00	3.20	10.02	1:.46:.22
	10	1.00	1.60	4.6	
	15	0.67	1.07	2.185	

Effect of the window size and proportion upon the distribution of light at reference points 5, 10, and 15 feet from the window corner.

8 x 4	1:1	15	0	0	0
4 x 8	1:2	15	-41.17%	-46.15%	-38.17%
(5.00) ²	1:2	15	-34.40%	-35.36%	-33.54%
3 x 3	1:3	15	0	0	0
3 x 6	1:2	10	-39.15%	-39%	-30%
(6.71) ²	1:2	15	-32.77%	-36%	-38.28%
10 x 5	1:2	10	0	0	0
5 x 10	1:2	10	-45%	-51.15%	-41.15%
(7.07) ²	1:2	10	-32.71%	-32.71%	-34.13%
10 x 6	1:2	10	0	0	0
6 x 10	1:1.67	10	-31.34%	-43.30%	-41.35%
(7.74) ²	1:2	10	-10.45%	-30%	-13.33%
10 x 7	1:2	10	0	0	0
7 x 10	1:1.43	10	-39.15%	-39.71%	-38.75%
(8.77) ²	1:2	10	-8.22%	-8.50%	-12.11%
10 x 8	1:2	10	0	0	0
8 x 10	1:1.25	10	-33.16%	-40%	-37.77%
(11.54) ²	1:2	10	-2.77%	-30%	-4.62%

TABLE 18

Ratio is Sky Component due to window in window proportion.

Continued.

Window Dimension H x W ft.	Window Proportion H:W	Max. Dist. from Win- dow ft. (D)	S.C. Losses due to Change in Window Proportions		
			at D/3	2/3D	D
4 x 3	1:1.75	10	0	0	0
3 x 4	1:1.33	10	-22.92%	-27.52%	-39.53%
(3.46) ²	1:1	10	-10.42%	-15.05%	-30.23%
5 x 3	1:1.6	11	0	0	0
3 x 5	1:1.67	11	-37.74%	-46.89%	-34.88%
(3.87) ²	1:1	11	-14.88%	-25.72%	-30.23%
6 x 4	1:1.67	13	0	0	0
4 x 6	1:1.5	13	-32.14%	-39.29%	-36.36%
(4.9) ²	1:1	13	-12.98%	-14.93%	-13.18%
7 x 4	1:1.75	15	0	0	0
4 x 7	1:1.75	15	-38.46%	-46.15%	-38.10%
(5.29) ²	1:1	15	-20.65%	-24.69%	-28.57%
8 x 4	1:2	15	0	0	0
4 x 8	1:2	15	-43.10%	-46.15%	-38.10%
(5.66) ²	1:1	15	-16.60%	-25.56%	-26.54%
9 x 5	1:1.8	16	0	0	0
5 x 9	1:1.8	16	-39.39%	-55%	-50%
(6.71) ²	1:1	16	-12.27%	-26%	-19.06%
10 x 5	1:2	18	0	0	0
5 x 10	1:2	18	-45%	-51.18%	-49.39%
(7.07) ²	1:1	18	-13.33%	-23.71%	-36.13%
10 x 6	1:1.67	18	0	0	0
6 x 10	1:1.67	18	-31.34%	-43.50%	-43.75%
(7.75) ²	1:1	18	-10.45%	-20%	-13.75%
10 x 7	1:1.43	18	0	0	0
7 x 10	1:1.43	18	-19.18%	-35.71%	-25.32%
(8.37) ²	1:1	18	-8.22%	-9.52%	-12.91%
10 x 8	1:1.25	18	0	0	0
8 x 10	1:1.25	18	-12.16%	-40%	-19.77%
(8.94) ²	1:1	18	-2.77%	-10%	-4.65%

TABLE 18

Losses in Sky Component due to variation in window proportion.

Continued.

Continued. TABLE 18

Window Dimension H x W ft.	Window Proportion H:W	Max. Dist. from Win- dow ft. (D)	S.C. Losses due to Change in Window Proportions		
			at D/3	2/3D	D
11 x 4 4 x 11 (6.63) ²	1:1.36 1:2.75 1:1	18 18 18	0 -58.97% -18.03%	0 -68.24% -36.18%	0 -71.93% -38.95%
11 x 5 5 x 11 (7.42) ²	1:1.45 1:2.2 1:1	18 18 18	0 -45.31% -11.56%	0 -58.50% -29%	0 -68.12% -33.12%
12 x 6 6 x 12 (8.49) ²	1:1.5 1:2 1:1	19 19 19	0 -38.73% -11.13%	0 -58.14% -20%	0 -57.94% -27.06%
12 x 7 7 x 12 (9.17) ²	1:1.58 1:1.71 1:1	20 20 20	0 -30.07% -9.02%	0 -41.81% -24.57%	0 -32.56% -23.95%
12 x 7 7 x 12 (9.17) ²	1:1.58 1:1.71 1:1	21 21 21	0 -31.92% -11.13%	0 -44.23% -20.19%	0 -36.22% -6.09%
12 x 8 8 x 12 (9.8) ²	1:1.67 1:1.50 1:1	21 21 21	0 -23.66% -7.84%	0 -33.48% -16.30%	0 -40.24% -8.02%
12 x 9 9 x 12 (10.39) ²	1:1.75 1:1.33 1:1	21 21 21	0 -15.36% -7.03%	0 -26.19% -2.78%	0 -27.04% -18.88%
13 x 7 7 x 13 (9.54) ²	1:1.54 1:1.86 1:1	15 15 15	0 -24.29% -4.69%	0 -44.44% -25%	0 -52.03% -23.76%
13 x 7 7 x 13 (9.54) ²	1:1.54 1:1.86 1:1	18 18 18	0 -34.28% -9.10%	0 -41.06% -11.92%	0 -48.12% -24.87%
13 x 8 8 x 13 (10.2) ²	1:1.62 1:1.63 1:1	21 21 21	0 -28.87% -8.82%	0 -43.08% -18.85%	0 -33.74% -22.70%
13 x 9 9 x 13 (10.82) ²	1:1.69 1:1.44 1:1	21 21 21	0 -21.22% -10.67%	0 -31.07% -14.64%	0 -20.13% -19.65%

Losses in Sky Component due to variation in window proportion.

Continued.

Continued. TABLE 18

Window Dimension H x W ft.	Window Proportion H:W	Max. Dist. from Win- dow ft. (D)	S.C. Losses due to Change in Window Proportions		
			at D/3	2/3D	D
14 x 7	1:1.50	15	0	0	0
7 x 14	1:2	15	-25.60%	-47.92%	-47.54%
(9.9) ²	1:1	15	-3.40%	-20%	-21.33%
14 x 8	1:1.57	18	0	0	0
8 x 14	1:1.75	18	-23.07%	-44.29%	-50.62%
(10.58) ²	1:1	18	-2.64%	-20.82%	-19.94%
14 x 9	1:1.64	21	0	0	0
9 x 14	1:1.56	21	-22.88%	-35.90%	-34.48%
(11.22) ²	1:1	21	-8.02%	-16.67%	-17.87%
14 x 10	1:1.71	21	0	0	0
10 x 14	1:1.4	21	-14.95%	-29.13%	-30.72%
(11.83) ²	1:1	21	-5.31%	-13.03%	-17.54%
15 x 7	1:1.47	18	0	0	0
7 x 15	1:2.14	18	-35.71%	-48.42%	-56.18%
(10.25) ²	1:1	18	-7.75%	-16.91%	-27.82%
15 x 8	1:1.53	21	0	0	0
8 x 15	1:1.88	21	-34.73%	-45.47%	-49.40%
(10.95) ²	1:1	21	-8.71%	-19.09%	-26.65%
15 x 10	1:1.67	21	0	0	0
10 x 15	1:1.5	21	-14.94%	-33.97%	-51.07%
(12.25) ²	1:1	21	-2.42%	-16.30%	-16.51%
16 x 8	1:1.50	18	0	0	0
8 x 16	1:2	18	-28.83%	-53.47%	-54.62%
(11.31) ²	1:1	18	-5.03%	-20.81%	-25.63%
16 x 9	1:1.56	18	0	0	0
9 x 16	1:1.78	18	-21.27%	-44.05%	-45.16%
(12.00) ²	1:1	18	-4.15%	-16.49%	-20.74%
16 x 10	1:1.63	21	0	0	0
10 x 16	1:1.6	21	-27.72%	-37.34%	-40.85%
(12.65) ²	1:1	21	-4.22%	-17.29%	-20.73%

Losses in Sky Component due to variations in window proportions.

Window Dimension H x W ft.	Window Proportion H:W	D ft.	Sky Component			Proportions of S.C.
			at D/3	at 2/3D	at D	
4 x 3	1:0.75	10	4.8	1.09	0.43	1:.23:.07
3 x 4	1:1.33	10	3.7	0.79	0.26	1:.21:.07
(3.46) ²	1:1.0	10	4.3	0.926	0.30	1:.22:.07
5 x 3	1:0.60	11	5.14	1.318	0.43	1:.26:.08
3 x 5	1:1.67	11	3.2	0.70	0.28	1:.22:.09
(3.87) ²	1:1.0	11	4.375	0.979	0.30	1:.22:.07
6 x 4	1:0.67	13	5.60	1.40	0.44	1:.25:.08
4 x 6	1:1.50	13	3.80	0.85	0.28	1:.22:.07
(4.90) ²	1:1.0	13	4.873	1.191	0.382	1:.24:.08
7 x 4	1:0.57	15	5.20	1.30	0.42	1:.25:.08
4 x 7	1:1.75	15	3.20	0.70	0.26	1:.22:.08
(5.29) ²	1:1.0	15	4.126	0.979	0.30	1:.24:.07
8 x 4	1:0.50	15	5.80	1.60	0.52	1:.28:.09
4 x 8	1:2.0	15	3.30	0.75	0.30	1:.23:.09
(5.66) ²	1:1.0	15	4.837	1.191	0.382	1:.24:.08
9 x 5	1:0.56	16	6.60	2.0	0.64	1:.30:.10
5 x 9	1:1.8	16	4.00	0.90	0.32	1:.23:.08
(6.71) ²	1:1.0	16	5.79	1.48	0.518	1:.26:.09
10 x 5	1:0.50	18	6.00	1.70	0.62	1:.28:.10
5 x 10	1:2.0	18	3.30	0.83	0.32	1:.25:.10
(7.07) ²	1:1.0	18	5.20	1.297	0.396	1:.25:.08
10 x 6	1:0.60	18	6.70	2.0	0.64	1:.30:.10
6 x 10	1:1.67	18	4.60	1.13	0.36	1:.25:.08
(7.75) ²	1:1.0	18	6.0	1.6	0.552	1:.27:.09
10 x 7	1:0.7	18	7.3	2.1	0.79	1:.29:.11
7 x 10	1:1.43	18	5.9	1.35	0.59	1:.23:.10
(8.37) ²	1:1.0	18	6.7	1.9	0.688	1:.28:.10
10 x 8	1:0.8	18	7.4	2.5	0.86	1:.34:.12
8 x 10	1:1.25	18	6.5	1.5	0.69	1:.23:.11
(8.94) ²	1:1.0	18	7.195	2.25	0.82	1:.31:.11

TABLE 19

Comparison between the light distribution from windows having equal areas but with different proportions.

Continued.

Window Dimension H x W ft.	Window Proportion H:W	D ft.	Sky Component			Proportions of S.C.
			at D/3	at 2/3D	at D	
11 x 4	1: .36	18	5.85	1.7	0.57	1: .29: .10
4 x 11	1: 2.75	18	2.4	0.54	0.16	1: .23: .10
(6.63) ²	1: 1.0	18	4.795	1.085	0.348	1: .23: .07
11 x 5	1: .45	18	6.4	2.0	0.69	1: .31: .11
5 x 11	1: 2.2	18	3.5	0.83	0.22	1: .24: .06
(7.42) ²	1: 1.0	18	5.66	1.42	0.4615	1: .25: .08
12 x 6	1: .50	19	7.1	2.15	0.85	1: .30: .12
6 x 12	1: 2.0	19	4.35	0.90	0.40	1: .21: .09
(8.49) ²	1: 1.0	19	6.31	1.72	0.62	1: .27: .10
12 x 7	1: .58	20	7.15	2.32	0.86	1: .32: .12
7 x 12	1: 1.71	20	5.0	1.35	0.58	1: .27: .12
(9.17) ²	1: 1.0	20	6.505	1.75	0.654	1: .27: .10
12 x 7	1: .58	21	6.83	2.08	0.624	1: .30: .09
7 x 12	1: 1.71	21	4.65	1.16	0.398	1: .25: .09
(9.17) ²	1: 1.0	21	6.07	1.66	0.586	1: .27: .10
12 x 8	1: .67	21	7.27	2.27	0.748	1: .31: .10
8 x 12	1: 1.5	21	5.55	1.51	0.447	1: .27: .08
(9.8) ²	1: 1.0	21	6.70	1.90	0.688	1: .28: .10
12 x 9	1: .75	21	7.68	2.52	0.932	1: .33: .12
9 x 12	1: 1.33	21	6.50	1.86	0.68	1: .29: .10
(10.39) ²	1: 1.0	21	7.14	2.18	0.756	1: .31: .11
13 x 7	1: .54	15	9.80	4.50	2.02	1: .46: .21
7 x 13	1: 1.86	15	7.42	2.50	0.969	1: .34: .13
(9.54) ²	1: 1.0	15	9.34	3.375	1.54	1: .36: .16
13 x 7	1: .54	18	8.52	2.952	1.303	1: .35: .15
7 x 13	1: 1.86	18	5.599	1.74	0.676	1: .31: .12
(9.54) ²	1: 1.0	18	7.745	2.60	0.979	1: .34: .13
13 x 8	1: .62	21	7.71	2.60	0.978	1: .34: .13
8 x 13	1: 1.63	21	5.484	1.48	0.648	1: .27: .12
(10.2) ²	1: 1.0	21	7.03	2.11	0.756	1: .30: .11
13 x 9	1: .69	21	8.34	2.8	1.108	1: .34: .13
9 x 13	1: 1.44	21	6.57	1.93	0.885	1: .29: .13
(10.82) ²	1: 1.0	21	7.45	2.39	0.926	1: .32: .12

Comparison between the light distribution from windows having equal areas but with different proportions.

Continued.

Window Dimension H x W ft.	Window Proportion H:W	D ft.	Sky Component			Proportions of S.C.
			at D/3	at 2/3D	at D	
14 x 7	1:.50	15	10.0	4.8	2.11	1:.48:.21
7 x 14	1:2.0	15	7.44	2.5	1.107	1:.34:.15
(9,9) ²	1:1.0	15	9.66	3.84	1.66	1:.40:.17
14 x 8	1:.57	18	8.987	3.89	1.62	1:.43:.18
8 x 14	1:1.75	18	6.914	2.167	0.80	1:.31:.12
(10,58) ²	1:1.0	18	8.75	3.08	1.297	1:.35:.15
14 x 9	1:.64	21	8.48	3.12	1.192	1:.37:.14
9 x 14	1:1.56	21	6.54	2.0	0.781	1:.31:.12
(11,22) ²	1:1.0	21	7.80	2.60	0.979	1:.33:.13
14 x 10	1:.71	21	8.76	3.33	1.38	1:.38:.16
10 x 14	1:1.4	21	7.45	2.36	0.956	1:.32:.13
(11,83) ²	1:1.0	21	8.295	2.90	1.138	1:.35:.14
15 x 7	1:.47	18	9.10	3.49	1.65	1:.38:.18
7 x 15	1:2.14	18	5.85	1.8	0.723	1:.31:.12
(10,25) ²	1:1.0	18	8.395	2.90	1.191	1:.35:.14
15 x 8	1:.53	21	8.424	3.09	1.257	1:.37:.15
8 x 15	1:1.88	21	5.498	1.685	0.636	1:.31:.12
(10,95) ²	1:1.0	21	7.69	2.50	0.922	1:.33:.12
15 x 10	1:.67	21	8.788	3.68	1.49	1:.42:.17
10 x 15	1:1.5	21	7.475	2.43	0.729	1:.33:.10
(12,25) ²	1:1.0	21	8.575	3.08	1.244	1:.36:.15
16 x 8	1:.50	18	9.835	4.47	1.99	1:.45:.20
8 x 16	1:2.0	18	7.00	2.08	0.903	1:.30:.13
(11,31) ²	1:1.0	18	9.34	3.54	1.48	1:.38:.16
16 x 9	1:.56	18	10.12	4.79	2.17	1:.47:.21
9 x 16	1:1.78	18	7.967	2.68	1.19	1:.34:.15
(12,00) ²	1:1.0	18	9.70	4.00	1.72	1:.41:.18
16 x 10	1:.63	21	9.24	3.99	1.64	1:.43:.18
10 x 16	1:1.6	21	6.68	2.5	0.97	1:.37:.15
(12,65) ²	1:1.0	21	8.85	3.30	1.30	1:.37:.15

Comparison between the light distribution from windows having equal areas but with different proportions.

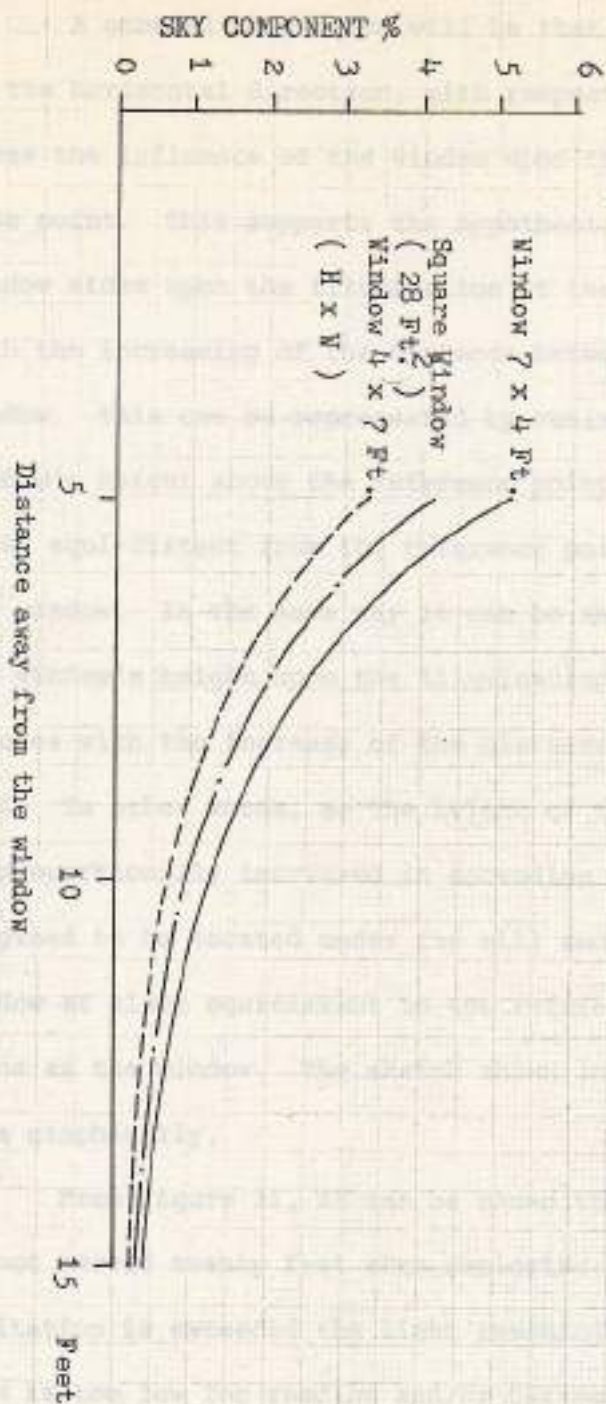

FIG. 30 A COMPARISON BETWEEN THE S.C. % OBTAINED FROM DIFFERENT WINDOW SHAPES OF THE SAME SURFACE AREA

Figure 30

A general conclusion will be that shifting a vertical window in the horizontal direction, with respect to the reference point, reduces the influence of the window upon the illumination at the reference point. This supports the hypothesis that the influence of the window sides upon the illumination at the reference point decreases with the increasing of the distance between the two sides of this window. This can be represented by vanishing lines connecting the window's height above the reference point to two vanishing points located equi-distant from the reference point but in the same plane as the window. In the same way it can be shown that the influence of the window's height upon the illumination at the reference point increases with the increase of the distance between the lintel and the sill. In other words, as the height of the window increases, light is proportionally increased in ascending rates. The vanishing point imagined to be located under the sill and connected to the top of the window at sides equidistant to the reference point, but in the same plane as the window. The sketch shown in Figure 29 illustrates this idea graphically.

From Figure 31, it can be shown that the maximum room depth cannot exceed twenty feet when employing side windows. When this limitation is exceeded the light reaching the remotest part of the room is too low for reading and/or taking notes. Accordingly, a reference point at the middle of this twenty foot distance can be chosen to represent the average distance, and a protractor can be designed from this point. A multitude of calculations of window widths can be made to determine the position of the vanishing points. Once this has

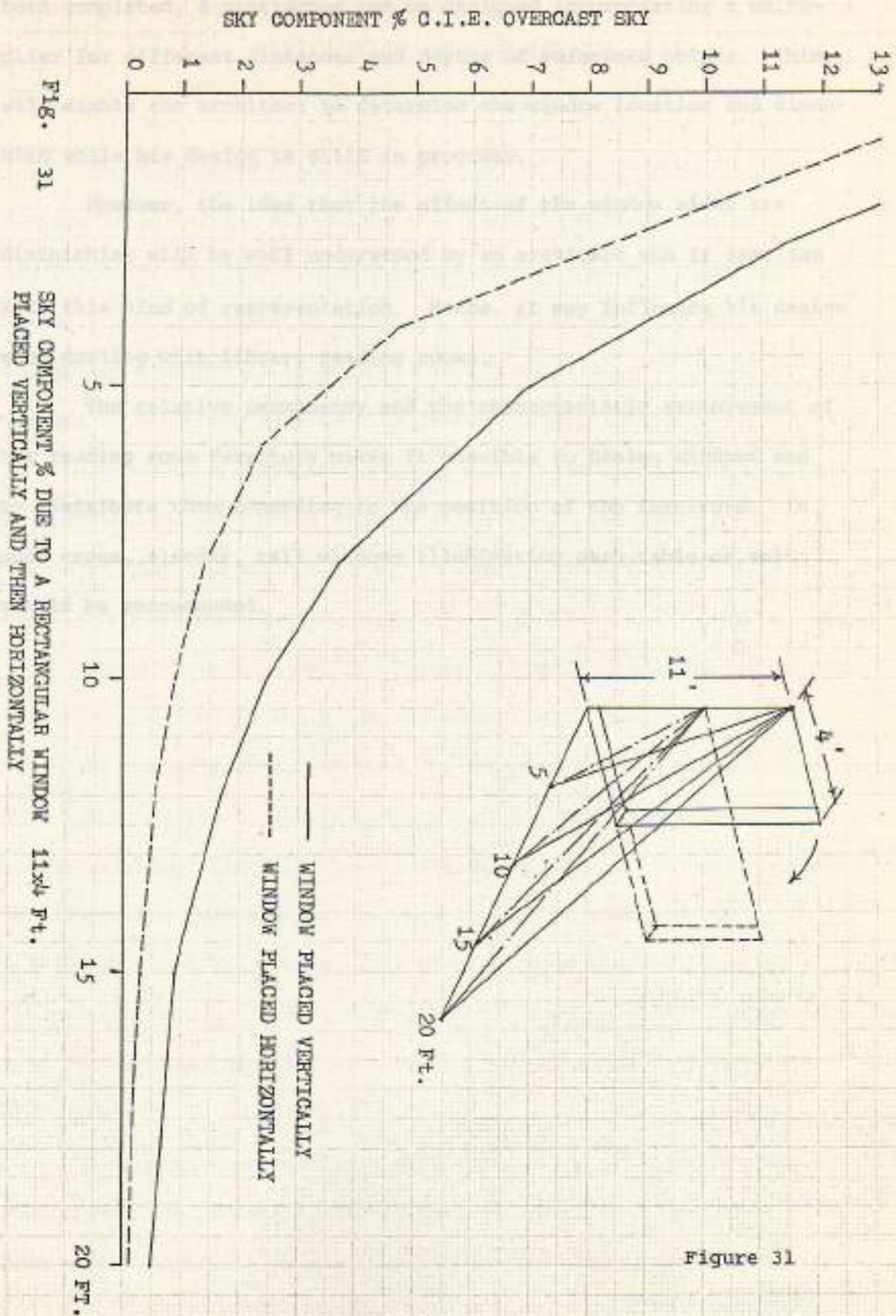

Figure 31

been completed, a protractor can be designed incorporating a multiplier for different distances and depths of reference points. This will enable the architect to determine the window location and dimension while his design is still in progress.

However, the idea that the effect of the window sides are diminishing will be well understood by an architect who is familiar with this kind of representation. Hence, it may influence his design when dealing with library reading rooms.

The relative permanency and the characteristic arrangement of the reading room furniture makes it possible to design windows and to distribute them according to the position of the furniture. In such cases, slender, tall windows illuminating each table or unit should be recommended.

Thirdly, to find out the resulting quality of light due to the condition described in the first and second parts mentioned above.

As formerly done, the A. N. V. Table for a C. I. H. overcast sky will be employed, and unlike the former study, the reference points were kept fixed in their positions throughout the test. Accordingly, the reference points were located at distances of 5, 10, and 15 feet from the window, following the same conditions as in the previous study. Tables 20 through 22 show the results obtained from the different angles of windows. The conclusions that can be drawn are:

a) For vertical windows, the distribution of light and its penetration are remarkably better than in the case of square windows or the horizontal windows having the same area. See Figure 21

Window Classification 1-1-1-1	By Component	Percentage of Distribution
<u>INFLUENCE OF THE WINDOW AREA</u>		

1-2-3	1-2	11.15%
1-2-4	1-2	24.16%
0-10		
<u>UPON THE ILLUMINATION</u>		

The purpose of this study is first of all, to find the influence of increasing the window area upon the illumination at a reference point. Will an increase in the window area be accompanied by a proportional increase in illumination? To answer this question, the square window will be employed in the test to avoid the consequences of utilizing windows with different proportions.

Secondly, a comparison will be made between the vertical, the horizontal, and the square windows as to their influences on illumination as they increase in area. Is there a limit after which a diminishing return occurs?

Thirdly, to find out the resulting quality of light due to the condition observed in the first and second parts mentioned above.

As formerly done, the B. R. S. Table for a C. I. E. overcast sky will be employed, and unlike the former study, the reference points were kept fixed in their positions throughout the test. Accordingly, the reference points were located at distances of 5, 10, and 15 feet from the window, following the same conditions as in the previous study. Tables 20 through 22 show the results obtained from the different samples of windows. The conclusions that can be drawn are:

- a) For vertical windows, the distribution of light and its penetration are remarkably better than in the cases of square windows or the horizontal windows having the same area. See Figure 32

Continued

Window Dimension H x W ft.	Sky Component at Distances from Window			Proportions of Distribution
	5 ft.	10 ft.	15 ft.	
4 x 3 3 x 4 (3.46) ² Area = 12 ft ²	2.2 1.6 1.84	0.34 0.26 0.30	0.116 0.08 0.093	1:.15:.05 1:.16:.05 1:.16:.05
5 x 3 3 x 5 (3.87) ² A = 15 ft ²	3.0 1.80 2.39	0.52 0.30 0.396	0.173 0.123 0.126	1:.17:.06 1:.17:.07 1:.17:.05
6 x 4 4 x 6 (4.90) ² A = 24 ft ²	4.50 3.10 3.34	0.98 0.62 0.756	0.313 0.215 0.252	1:.22:.07 1:.20:.07 1:.23:.08
7 x 4 4 x 7 (5.29) ² A = 28 ft ²	5.20 3.20 4.45	1.30 0.70 0.979	0.411 0.225 0.30	1:.25:.08 1:.22:.07 1:.22:.07
8 x 4 4 x 8 (5.66) ² A = 32 ft ²	5.80 3.30 4.915	1.60 0.75 1.191	0.523 0.252 0.372	1:.28:.09 1:.23:.08 1:.24:.08
9 x 5 5 x 9 (6.71) ² A = 45 ft ²	7.10 3.60 6.27	2.20 1.20 1.72	0.812 0.424 0.620	1:.31:.11 1:.33:.12 1:.27:.10
10 x 5 5 x 10 (7.07) ² A = 50 ft ²	7.50 4.70 6.719	2.60 1.30 1.97	0.973 0.425 0.681	1:.35:.13 1:.28:.09 1:.29:.10
10 x 6 6 x 10 (7.75) ² A = 60 ft ²	8.30 6.10 7.525	3.0 1.80 2.46	1.104 0.676 0.926	1:.36:.13 1:.30:.11 1:.33:.12
10 x 7 7 x 10 (8.37) ² A = 70 ft ²	8.70 7.30 8.185	3.30 2.30 2.84	1.358 0.921 1.138	1:.38:.16 1:.32:.13 1:.35:.14

Sky Component distribution at 5, 10, and 15 feet, due to variations in window proportions.

TABLE 20

Continued.

Continued.

TABLE 20

Window Dimension H x W ft.	Sky Component at Distances from Window			Proportions of Distribution
	5 ft.	10 ft.	15 ft.	
10 x 8 8 x 10 (8.94) ² A = 80 ft ²	9.10 8.60 8.755	3.60 2.90 3.14	1.251 1.09 1.30	1:.40:.14 1:.34:.13 1:.36:.15
11 x 4 4 x 11 (6.63) ² A = 44 ft ²	7.00 3.30 6.245	2.50 0.905 1.52	0.90 0.326 0.586	1:.36:.13 1:.27:.10 1:.24:.09
11 x 5 5 x 11 (7.42) ² A = 55 ft ²	7.90 4.74 7.022	3.00 1.35 2.22	1.138 0.488 0.756	1:.38:.14 1:.28:.10 1:.32:.11
12 x 6 6 x 12 (8.49) ² A = 72 ft ²	9.10 6.18 8.35	3.80 1.90 2.90	1.60 0.75 1.191	1:.42:.18 1:.31:.12 1:.35:.14
12 x 7 7 x 12 (9.17) ² A = 84 ft ²	9.50 7.38 8.95	4.20 2.50 3.42	1.81 0.995 1.36	1:.44:.19 1:.34:.12 1:.38:.15
12 x 8 8 x 12 (9.8) ² A = 96 ft ²	10.00 8.36 9.62	4.50 3.10 3.78	1.99 1.25 1.60	1:.45:.20 1:.37:.15 1:.39:.17
12 x 9 9 x 12 (10.39) ² A = 108 ft ²	10.40 9.16 9.743	4.80 3.70 4.30	2.20 1.60 1.84	1:.46:.21 1:.40:.17 1:.44:.19
13 x 7 7 x 13 (9.54) ² A = 91 ft ²	9.80 7.42 9.395	4.50 2.50 3.60	2.02 1.044 1.54	1:.46:.21 1:.34:.14 1:.38:.16
13 x 8 8 x 13 (10.20) ² A = 104 ft ²	10.20 7.92 9.736	4.90 3.15 4.18	2.20 1.32 1.78	1:.48:.22 1:.40:.17 1:.43:.18

Sky-Component distribution at 5, 10, and 15 feet, due to variations in window proportions.

Continued.

Continued. TABLE 20

Window Dimension H x W ft.	Sky Component at Distances from Window			Proportions of Distribution
	5 ft.	10 ft.	15 ft.	
13 x 9 9 x 13 (10.82) ² A = 117 ft ²	10.80 9.22 10.135	5.20 3.75 4.60	2.48 1.67 2.04	1:.48:.22 1:.41:.18 1:.45:.20
14 x 7 7 x 14 (9.90) ² A = 98 ft ²	10.00 7.48 9.62	4.80 2.50 3.84	2.20 1.167 1.52	1:.48:.22 1:.33:.16 1:.40:.16
14 x 8 8 x 14 (10.58) ² A = 112 ft ²	10.50 8.48 10.003	5.20 3.20 4.45	2.44 1.38 1.97	1:.50:.23 1:.38:.16 1:.44:.20
14 x 9 9 x 14 (11.22) ² A = 126 ft ²	11.10 9.28 10.544	5.60 3.80 4.86	2.72 1.73 2.25	1:.50:.23 1:.41:.19 1:.46:.21
14 x 10 10 x 14 (11.83) ² A = 140 ft ²	11.40 9.98 10.847	5.90 4.50 5.04	2.86 2.08 2.53	1:.52:.25 1:.45:.21 1:.46:.23
15 x 7 7 x 15 (10.25) ² A = 105 ft ²	10.20 7.50 9.845	5.10 2.55 4.225	2.48 1.177 1.78	1:.50:.24 1:.34:.16 1:.43:.18
15 x 8 8 x 15 (10.95) ² A = 120 ft ²	10.70 8.50 10.32	5.60 3.25 4.75	2.72 1.45 2.11	1:.52:.25 1:.38:.17 1:.46:.20
15 x 10 10 x 15 (12.25) ² A = 150 ft ²	11.70 10.00 11.17	6.20 4.55 5.595	3.21 2.15 2.72	1:.53:.27 1:.46:.22 1:.50:.24

Sky Component distribution at 5, 10, and 15 feet, due to variations in window proportions.

Continued.

Continued.

TABLE 20

Window Dimension H x W ft.	Sky Component at Distances from Window			Proportions of Distribution
	5 ft.	10 ft.	15 ft.	
16 x 8	10.86	5.80	3.0	1:.53:.28
8 x 16	8.52	3.30	1.52	1:.39:.18
(11.31) ² A = 128 ft ²	10.656	4.915	2.25	1:.46:.21
16 x 9	11.40	6.20	3.28	1:.54:.29
9 x 16	9.32	3.90	1.835	1:.42:.20
(12.00) ² A = 144 ft ²	10.94	5.40	2.60	1:.49:.24
16 x 10	11.80	6.50	3.49	1:.55:.30
10 x 16	10.02	4.60	2.185	1:.46:.22
(12.65) ² A = 160 ft ²	11.38	5.855	2.84	1:.51:.25

Sky Component distribution at 5, 10, and 15 feet, due to variations in window proportions.

12 x 8	11.88:30	11.37:40	11.71:44
12 x 7	11.76:30	11.34:40	11.59:43
12 x 6	11.70:30	11.31:40	11.40:41
13 x 8	11.88:34	11.72:46	11.67:47
13 x 7	11.75:34	11.57:46	11.58:45
13 x 6	11.63:34	11.52:46	11.57:45
14 x 8	11.88:38	11.68:47	11.68:47
14 x 7	11.80:38	11.76:47	11.77:48
14 x 6	11.74:38	11.80:47	11.67:47
15 x 8	11.70:42	11.54:48	11.53:47
15 x 7	11.55:42	11.72:48	11.67:47
15 x 6	11.70:42	11.57:48	11.51:47
16 x 8	11.82:46	11.62:49	11.56:47
16 x 7	11.65:46	11.72:49	11.61:47

TABLE 21

Comparison between the proportions of sky component distribution for horizontal and square windows relative to the vertical window.

Window size H x W ft.	Proportion of Sky Component		
	at Distance 5 ft.	at Distance 10 ft.	at Distance 15 ft.
	V H S	V:H:S	V:H:S
4 x 3	1: .73: .84	1: .76: .88	1: .69: .80
5 x 3	1: .60: .80	1: .58: .75	1: .71: .73
6 x 4	1: .69: .74	1: .63: .77	1: .69: .81
7 x 4	1: .62: .86	1: .54: .75	1: .55: .73
8 x 4	1: .69: .85	1: .47: .74	1: .46: .71
9 x 5	1: .51: .88	1: .55: .78	1: .52: .76
10 x 5	1: .63: .90	1: .50: .76	1: .44: .70
10 x 6	1: .73: .91	1: .60: .82	1: .61: .84
10 x 7	1: .84: .94	1: .70: .86	1: .68: .84
10 x 8	1: .95: .96	1: .81: .87	1: .87: 1.04
11 x 4	1: .47: .89	1: .36: .61	1: .36: .65
11 x 5	1: .60: .89	1: .45: .74	1: .43: .66
12 x 6	1: .68: .92	1: .50: .75	1: .47: .74
12 x 7	1: .78: .94	1: .60: .81	1: .55: .75
12 x 8	1: .84: .96	1: .69: .74	1: .63: .80
12 x 9	1: .88: .96	1: .77: .90	1: .73: .84
13 x 7	1: .76: .96	1: .56: .80	1: .52: .76
13 x 8	1: .78: .95	1: .64: .85	1: .60: .81
13 x 9	1: .85: .94	1: .72: .88	1: .67: .82
14 x 7	1: .75: .95	1: .52: .80	1: .53: .69
14 x 8	1: .81: .95	1: .62: .86	1: .57: .81
14 x 9	1: .84: .95	1: .68: .87	1: .64: .83
14 x 10	1: .88: .95	1: .76: .85	1: .73: .88
15 x 7	1: .74: .97	1: .50: .83	1: .47: .72
15 x 8	1: .79: .96	1: .58: .85	1: .53: .78
15 x 10	1: .85: .95	1: .73: .90	1: .67: .85
16 x 8	1: .78: .98	1: .57: .85	1: .51: .75
16 x 9	1: .82: .96	1: .63: .87	1: .56: .79
16 x 10	1: .85: .96	1: .71: .90	1: .63: .81

TABLE 21

Comparison between the proportions of Sky Component distribution for horizontal and square windows relative to the vertical window.

For Square Windows; Area Increase		Relative increase of S.C. with double increase in window area			Average increase in % within 15 ft. from source
From	To	At reference point 5 ft. from source	At reference point 10 ft. from source	At reference point 15 ft. from source	
12 ft.	24 ft.	81.52%	152%	170.97%	134.51
15 ft.	30 ft.	98.74%	173.99%	176.19%	149.64
24 ft.	48 ft.	98.65%	143.39%	159.52%	133.85
30 ft.	60 ft.	58.42%	126.73%	166.09%	117.08
44 ft.	88 ft.	47.32%	132.89%	152.56%	110.92
50 ft.	100 ft.	44.37%	103.05%	152.57%	99.96
55 ft.	110 ft.	49.25%	97.07%	151.32%	99.21
60 ft.	120 ft.	37.14%	93.09%	127.86%	86.03
70 ft.	140 ft.	32.52%	77.46%	122.32%	77.43
72 ft.	144 ft.	31.62%	86.21%	118.30%	78.71
80 ft.	160 ft.	29.98%	86.46%	118.46%	78.30

TABLE 22

Relative increase of Sky Component with double increase in the areas of square windows for reference points 5, 10, and 15 feet away from the window corner.

SKY COMPONENT % C.I.E. OVERCAST SKY

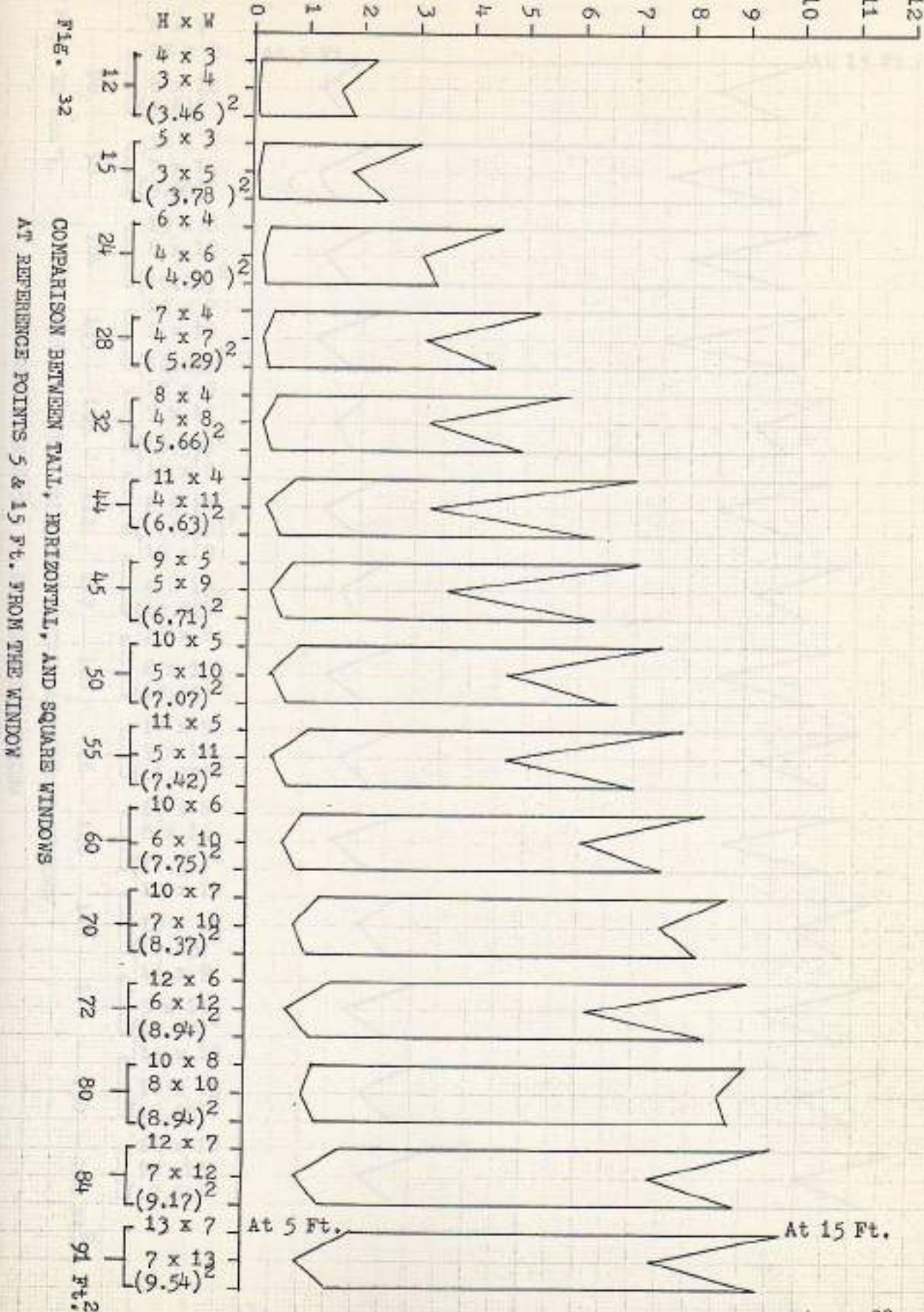

Figure 32

SKY COMPONENT % C.I.E. OVERCAST SKY

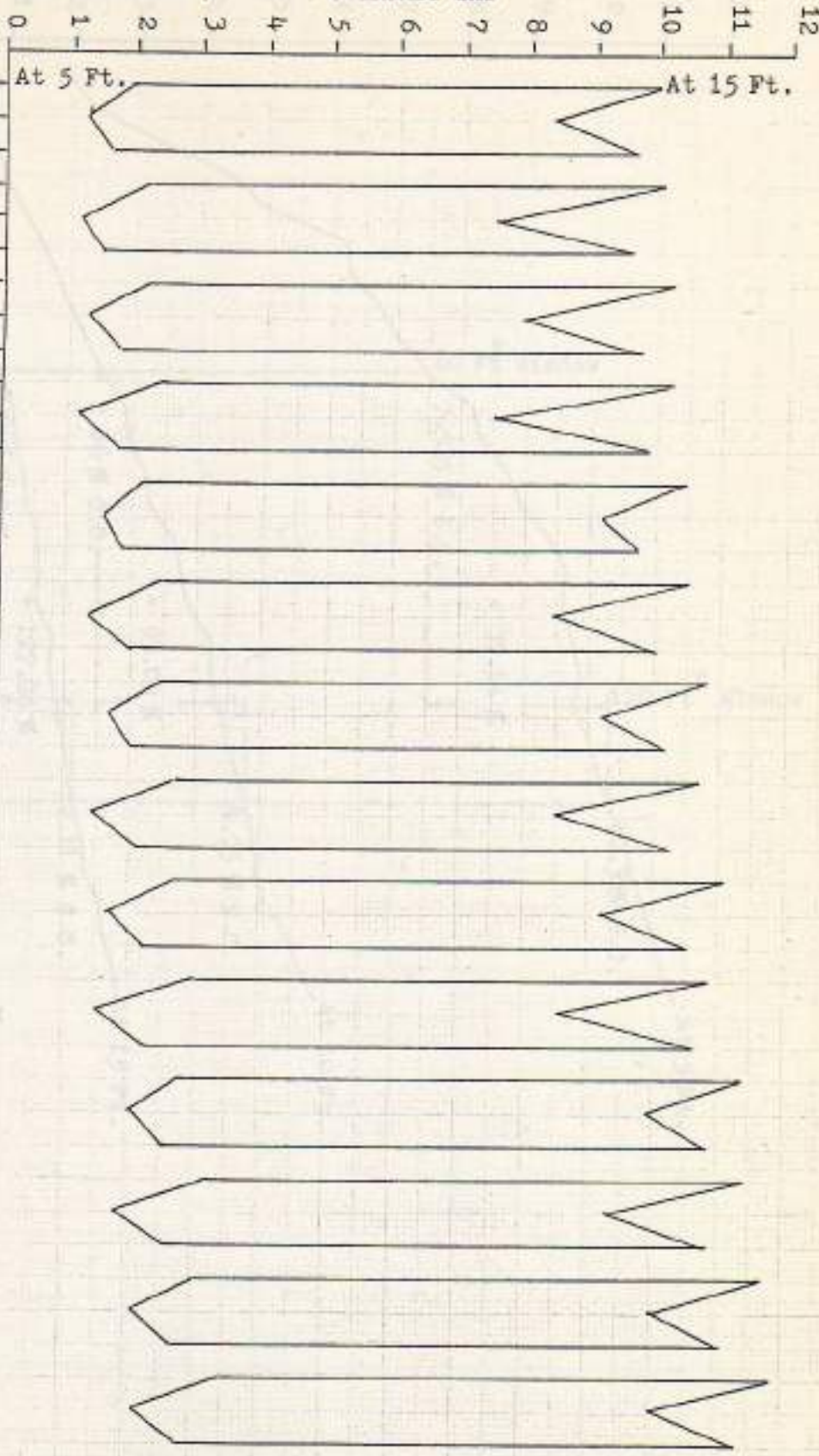

Fig. 32 con't.

COMPARISON BETWEEN TALL, HORIZONTAL, AND SQUARE WINDOWS
AT REFERENCE POINTS 5 & 15 Ft. FROM THE WINDOW

SKY COMPONENT % C.I.E. OVERCAST SKY

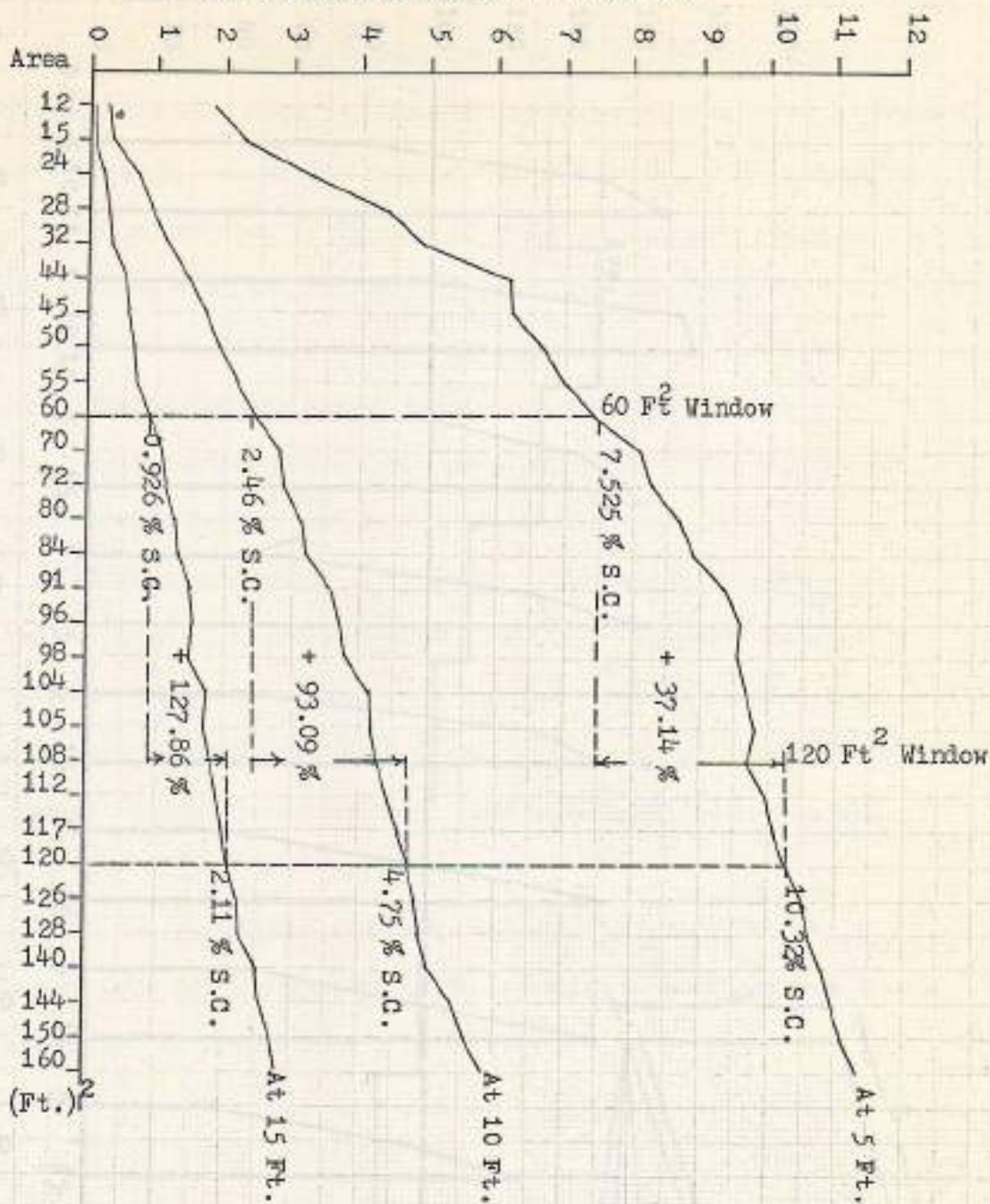

FIG. 33

RELATION BETWEEN THE AREA OF A SQUARE WINDOW AND ITS S.C. % AT DISTANCES 5, 10, and 15 FEET

PERCENTAGE OF S.C. INCREASE

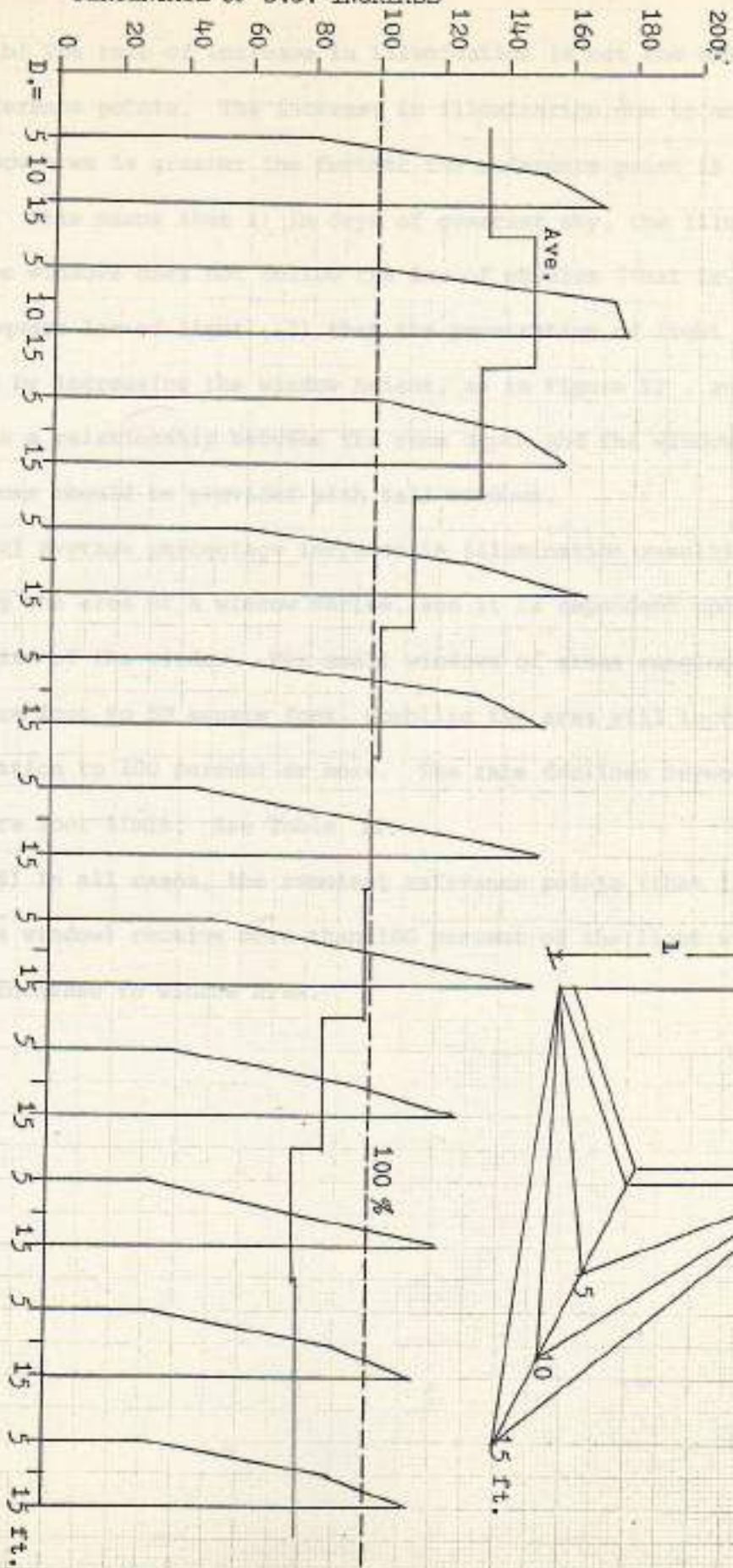

Fig. 34

RELATIVE S.C. % INCREASE WITH DOUBLE INCREASE OF WINDOW AREAS (For Square Windows)

Ft.²

12-24

15-30

24-48

30-60

44-88

50-100

55-110

60-120

70-140

72-144

80-160

15 ft.

100%

Ave.

L

L

5

10

15 ft.

b) The rate of increase in illumination is not the same for all the reference points. The increase in illumination due to an increase in window area is greater the further the reference point is from the window. This means that 1) in days of overcast sky, the illumination from the windows does not follow the law of physics (that is, the inverse square law of light), 2) that the penetration of light is achieved by increasing the window height, as in Figure 32, and 3) that there is a relationship between the room depth and the window height. Deep rooms should be provided with tall windows.

c) Average percentage increase in illumination resulting from doubling the area of a window varies, and it is dependent upon the initial size of the window. For small windows of areas ranging from 12 square foot to 50 square foot, doubling the area will increase the illumination to 100 percent or more. The rate declines beyond the 50 square foot limit. See Table 22.

d) In all cases, the remotest reference points (that is, 15 ft. from the window) receive more than 100 percent of the light with every double increase in window area.

INFLUENCE OF THE WINDOW AREA, POSITION AND
SLOPE ON THE LIGHT IN THE INTERIOR

The purpose of this study is to determine the influence of the window position, area and reveal shape on the quantity and distribution of light on the work plane.

To simplify the problem, it is assumed that the window being tested is water in the middle of or at one side of the exterior wall with one of the following three types of reveals:

- a) straight reveal
- b) reveal bevelled to the interior at 45 degrees
- c) reveal bevelled to the exterior at 45 degrees.

PART III

The research method involved constructing a model having a window slope and position which can be adjusted within a short span of time, as natural light is variable. Furthermore, the experiment was conducted during a given period of time of the day with specific lighting conditions, thus minimizing the number of variables. The experiment was repeated employing artificial lighting to see whether the distribution of light would be the same or different.

A model at a scale of 1:20 was constructed representing a room measuring 4.75 meters in length, 1.50 meters in breadth, and 2.75 meters in height. The long wall contained the window.

Another factor taken into consideration was that the internal surfaces of the room had a reflection factor of 65 percent to avoid over illumination of light, while at the same time permitting remote

200

INFLUENCE OF THE WINDOW SIZE, POSITION AND
REVEAL SHAPE UPON THE LIGHT IN THE INTERIOR

The purpose of this study is to determine the influence of the window position, area and reveal shape on the quantity and distribution of light on the work plane.

To simplify the problem, it is maintained that the window being tested is whether in the middle of or at one side of the exterior wall with one of the following three types of reveal:

- a) straight reveal
- b) reveal bevelled to the exterior at 45 degrees
- c) reveal bevelled to the interior at 45 degrees.

The research method involved constructing a model having a window shape and position which can be adjusted within a short span of time, as natural light is variable. Furthermore, the experiment was conducted during a given period of time of the day with specific lighting conditions, thus minimizing the number of variables. The experiment was repeated employing artificial lighting to see whether the distribution of light would be the same or different.

A model at a scale of 1:20 was constructed representing a room measuring 4.00 meters in length, 3.50 meters in breadth, and 2.75 meters in height. The long wall contained the window.

Another factor taken into consideration was that the internal surfaces of the room had a reflection factor of 65 percent to avoid over absorption of light, while at the same time permitting remote

areas to receive light from interreflections. If the room surfaces were of a low reflective material, areas beyond the direct light would not receive enough light to energize the light meter and hence, the results would not reflect the actual case. Also, to avoid the influence of specularity, the room surfaces chosen were of a matt material. Light reflected from a specular surface to the light meter can cause misleading results since that light is directional and does not represent the actual condition of light in the area being tested. Another consideration was the influence of the ground in front of the window. The model was tested upon a surface having a reflection factor of 23 percent, representing grass and tested again upon a surface having a reflectance of 55 percent representing concrete.

The initial window size was 1.30 meters high and 1.20 meters wide. The sill and window heights were maintained constant throughout the experiment.

The thickness of the exterior wall was made equal to the common thickness of 0.29 meters of contemporary walls (one brick thick plus the internal and external coat).

In the experiment the window had two different settings, one located in the middle of the facade, the other at the right side of the room.

The floor of the room was divided into nine equal areas with two readings of the level of illumination in each area:

- 1) at the floor, and
- 2) on the work plane, 0.85 meters above the floor.

Overcast skies were selected as the daylight source of illumination for the following reasons:

1) Light reaching a window is the sum of the direct light from the sun, scattered light from the sky, and light reflected from external surfaces. With clear skies, the external surfaces reflecting light to the window may receive direct sunlight on one occasion and indirect sunlight on another occasion. Furthermore, the rotation of the earth will affect the relative position of the sun which in turn, changes the brightness distribution of the external environment. Accordingly, the light reflected to the window will fluctuate continuously. This, along with the possibility of cloud build-up or movement in the area of the experiment, would render the results useless.

2) In the case of direct sunlight and its effect on the model, the test might reflect the path of the sun, rather than the quantity of light alone.

Taking into consideration the above mentioned difficulties, days with totally overcast skies were selected for the experiment. The average level of illumination falling upon the window was about 375 ft-c. Each time the available light was measured at the exterior as well as the interior of the reference points. Thus, the results indicated in the accompanying data represent the ratio of light admitted by a window, to the light falling on the exterior.

The model was located on a plane having a height of 7.00 meters above the street. Time and orientation were maintained constant. The model was oriented so that the window faced Northeast. This not only permitted the reception of a relatively constant light during an appropriate interval of time, but also it avoided massive obstructions due to the location of the experiment on the second floor of the Fur-

ness Building of the University of Pennsylvania. The buildings opposite the model's window located at remote distances (as seen in Figure 4)] had walls of dark red brick and dark slate roofs with a very low reflection factor. Owing to the great distance from the model (approximately 100 feet), one can safely assume that they made no significant contribution to the illumination reaching the model.

In experimenting with natural light, the time of measurement was from 12:30 P.M. to 4:30 P.M., local time, through the period of November 23, 1976 to January 15, 1977.

Experiments with artificial lighting were done using fluorescent luminaries arranged in pairs within a white enamel reflector. The lamps were located near the window to give 1000 ft-c. at all points of the window. The height of the window was equal to the distance between the outsides of the pairs of lamps, and this dimension was kept constant throughout the experiment. This arrangement made it possible for that light to equal light coming from an infinite sky and permitted the remote parts of the room to receive direct light from the luminaries which was not the case when experimenting with daylight. The results duplicated those obtained under natural lighting conditions but at a lower intensity, because light from the lamp decreases sharply with increased distances.

The light meter used was a color and cosine corrected light meter manufactured by General Electric U. S. A., which used selenium cell with a specific filter mounted over the cell in order to produce a sensitivity similar to that of the human eye.

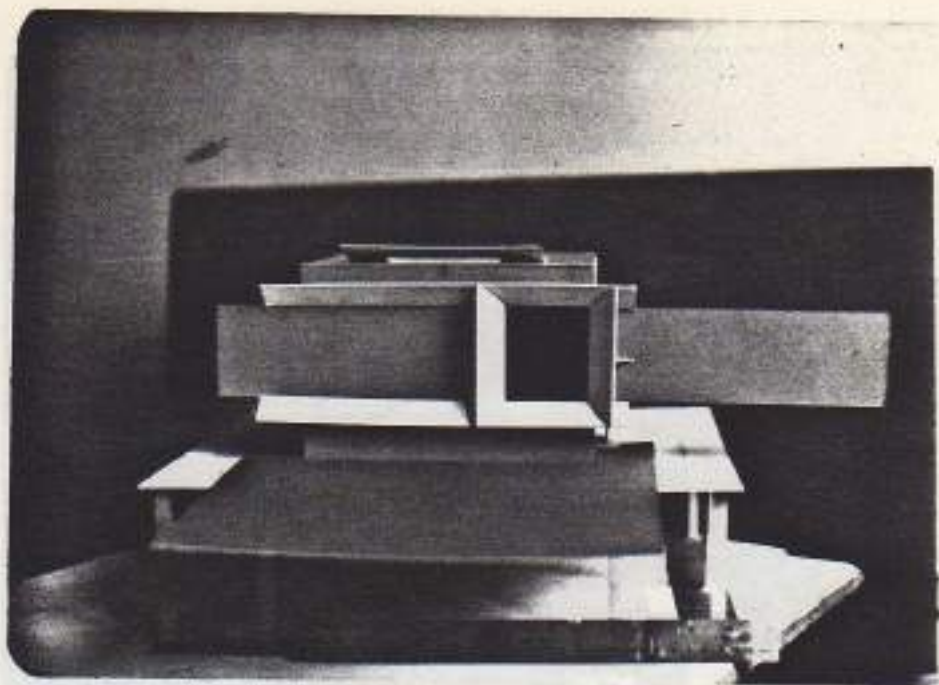

Figure 35 Model of the room showing the window with reveals bevelled to the exterior and positioned at one side of the side wall.

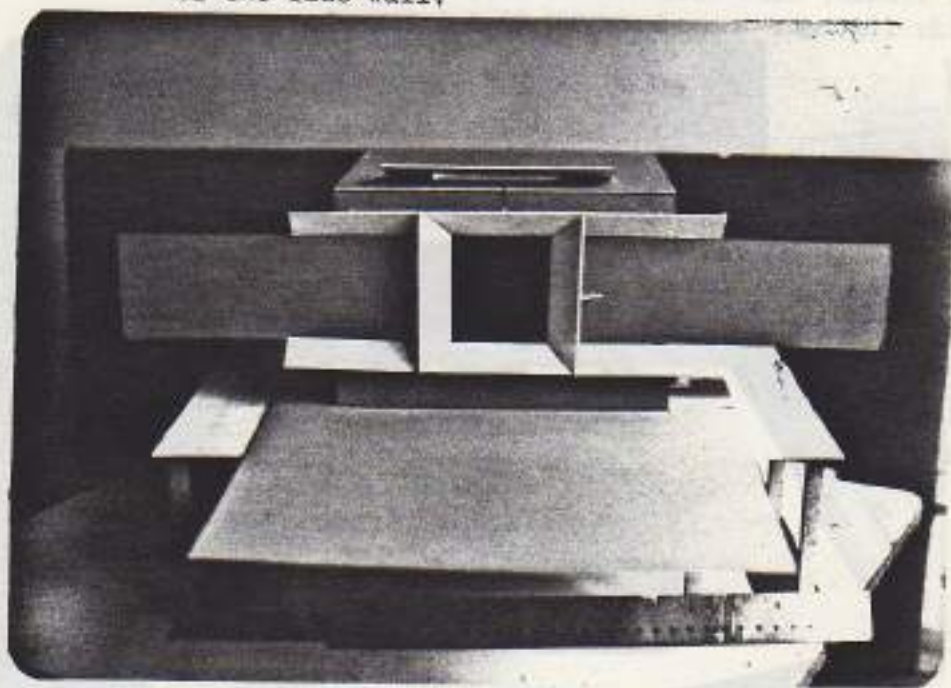

Figure 36 Model of the room showing the window with reveals bevelled to the exterior and positioned in the center of the elevation (Window can be enlarged in width by sliding the two sides).

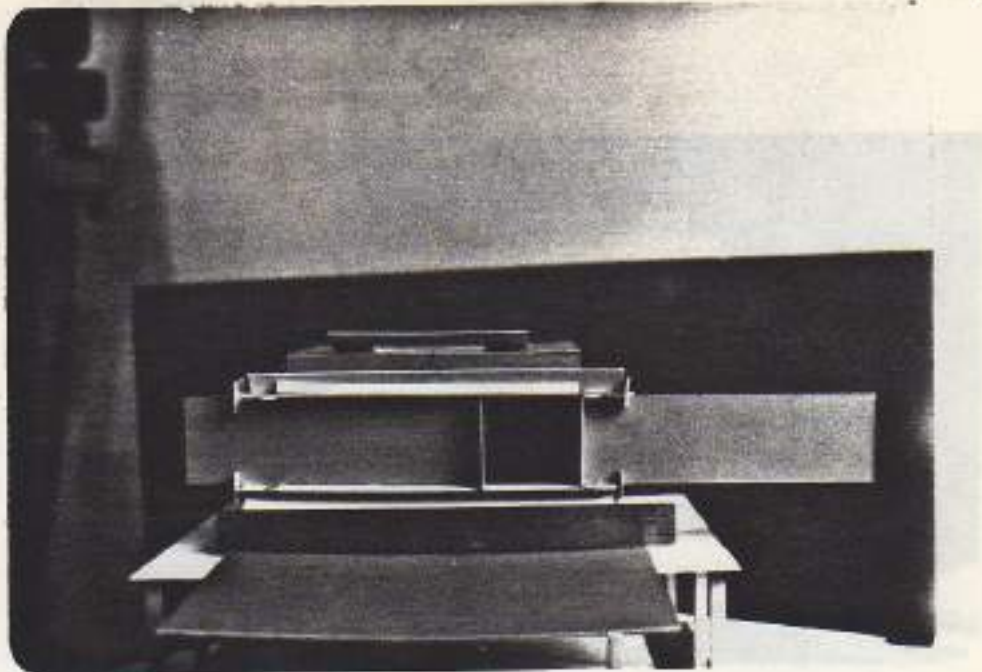

Figure 37 Model of the room having a window with square reveals and located at one side of the side wall (Window reveals are extended 0.12 Meters beyond the wall thickness).

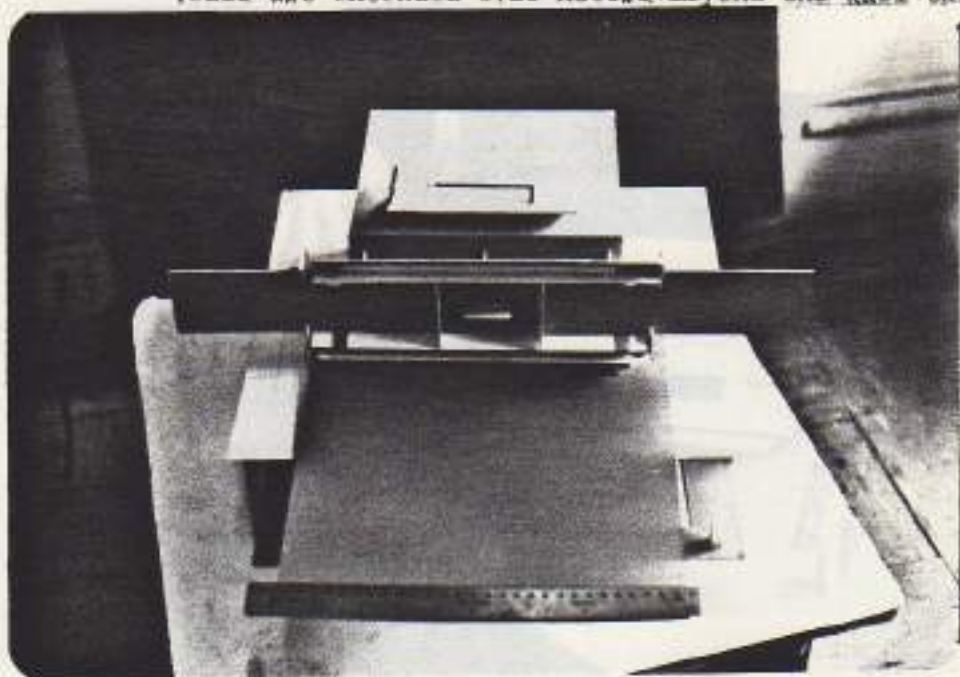

Figure 38 View of the room showing the window with square reveals positioned at the center of the elevation and the simulated lawn.

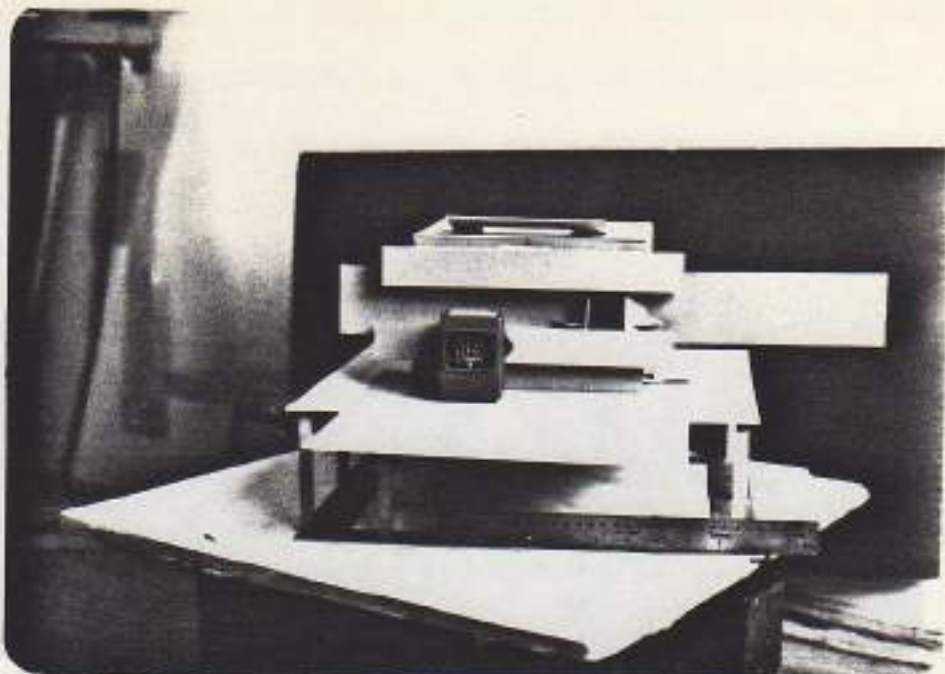

Figure 39 Model showing the room with window having reveals bevelled to the interior. The light meter shown is a color and cosine corrected light meter from General Electric, U.S.A.



Figure 40 Model of the room showing how the window with reveals bevelled to the interior is centered and extended in width.



Figure 41 View of the environment as seen by the window of the model on an overcast sky day,



Figure 42 View of the environment facing the window of the model showing the pitched roofs of the opposite buildings at about 100 feet from the model.

The data obtained from the experiment, along with an analytical study of the findings, can be seen in Appendix IV. Conclusion:

1) The findings show that the shape of the window reveal has a significant influence upon the distribution and quality of illumination admitted into the building. The external reveal is more efficient in this respect than the square reveal and internal reveal.

2) It was observed that even on the most overcast days the level of illumination was far higher than the universally accepted standard of 500 ft-c. The general experience of the author in those European situations where the skies are less bright was that this standard is minimal or perhaps substantial. The brighter skies in Philadelphia would permit a much higher standard as a basic requirement. However, it is not possible to determine precisely the illumination to be expected in any given orientation since this is dependent upon the sun altitude which differs depending upon the time of day, the latitude, and the season. Accordingly, the lighting design for interiors has to take into account the variations in natural lighting throughout the day and throughout the year.

3) The findings have demonstrated that the daylight illumination at a reference point inside the room depends upon the luminosity of the area of the sky visible from that point. Based on the following observations:

a) the illumination inside the room declines rapidly with increasing distance from the window, especially after the first meter of this distance.

b) Another observation is that rooms having a window located

b) the impact of the light reflected from either the lawn or the concrete into the interior of the room is very small compared to the impact of the sky's illumination.

c) although the area under the window sill is nearby, it is submerged in darkness because it is hidden from the sky.

d) the intensity of light is highest on the plane perpendicular to the center of the window at the level of the work plane and diminishes on either side.

4) According to the findings described in number 3 above, the horizontal window, when tilted vertically, will produce better illumination. For instance, because a window with an external bevel provides a reference point with a better view of the sky than if the reveal is internally bevelled, this reference point should receive more illuminance value according to the findings. In my experiment, maximum illuminance values were obtained when employing the external reveal. For example, a reference point located at the center of the room at the work level received 5.5 times more illuminance when employing the external reveal than the internal reveal. In this example, the window size was 1.30 meters x 1.80 meters (see table). With the window occupying the total length of the wall (4.00 meters) the reference point received two and one third times more illuminance when employing the external reveal than if the reveal was internal.

5) Another observation is that rooms having a window located

to one side of the center line of the exterior wall appear to be poorly lit because of the contrast produced between the areas remote from the window. Even though the illumination in the remote areas may be adequate for visual task performance, aesthetic dissatisfaction may be experienced.

When the window area is increased thus raising the illumination at the back of the room, the illumination near the window also increases, however, the ratio between the lightest and darkest areas remains the same. Thus, it is recommended that additional natural light (a secondary window or skylight) be provided in the remote areas of the room to brighten them without destroying the essential character and direction of the dominant source of light.

6) Dr. Kleffner's theory that increasing the window areas does not produce a proportional increase in the illumination of the room, was found to be valid in only one special case. In the case of windows with exterior bevels, my experiments tend to confirm Dr. Kleffner's conclusions. In the case of square and interior bevels, however, the increases vastly exceeded Dr. Kleffner's 59 percent increase with the doubling of the window size¹, which in my studies showed respectively, increases of 100 percent and 169 percent. The figures are deceptive, however. If we applied the theory of Dr. Kleffner to our examples, the window which increased the brightness by 169 percent,

¹Ernst Neufert: Architects Data, Crosby Lockwood, and Son Ltd., London, 1970, p. 73.

when its size is doubled, would be the most preferable window in terms of the high percentage of increase in brightness in proportion to increased window size. In fact, the window with the external reveal whose doubled size increased the brightness by about 46 percent, actually provided as much as 136 percent more brightness than that which increased the brightness by 169 percent (that is, the window with the internal reveal). The reason is that the window with the external reveal is now being compared to the actual value of the brightness of the window with internal reveal rather than to itself.

7) Regardless of the location of the window, whether at the middle of the wall or at its side, the total quantity of illuminance in the room does not change but its distribution which affects the appearance of the room.

The essential function of the eye is the ability to see, and daylight makes this possible for the greater part of human activity. Human sight is adapted to the light spectrum transmitted by the atmosphere. However, the adaptability of the eye is not absolute; the man's pupil with the addition of the scattered light from the sky, absorbs more than the spectral sensitivity of the eye. The eye has different sensitivities to colors. It is sensitive to green and yellow more than to blue or red¹. However, the retina itself is not uniformly sensitive to light. The sensitivity at the periphery is smaller than in the center. This variation of sensitivity is due to the fact that the eye is not a simple camera. The light entering the eye is focused on the retina and the eye adapts to the light. The light-adapted eye has its maximum sensitivity near 555 mμ (approximately), while the dark-adapted eye is sensitive to no wave that 505 mμ². Consequently, the green color of the spectrum (505 mμ) appears brighter when viewed with the dark-adapted eye, while yellow (585 mμ) appears to be brighter when viewed with the light-adapted eye³. This is because the pigment in the cones

¹E. S. Mollison, F. Peckwithridge, T. Anderson. Psychology, Baltimore, London, 1900, p. 1.

²Lloyd Kaufman, Light and Mind, An Introduction to Psychology, New York, Oxford University Press, London, Toronto, 1936, p. 21.

³*Ibid.*, p. 21.

⁴*Ibid.*, p. 21.

⁵*Ibid.*, p. 21.

PSYCHOPHYSICAL INFLUENCES OF NATURAL LIGHT

The essential function of the eye is its ability to see, and daylight makes this possible for the greater part of human activity. Human sight is adapted to the light spectrum transmitted by the atmosphere. However, the adaptability of the eye is not absolute¹. The sun's light, with the addition of the scattered light from the sky, exceeds many times the spectral sensitivity of the eye. The eye has different sensations to colors. It is sensitive to green and yellow more than to blue or red². Moreover, the retina itself is not uniformly sensitive to light. The sensitivity at the periphery is greater than in the center³, thus wandering or fixation causes variability in detection at each light level. Accordingly, more light is needed in the fovea than in the adjacent areas if both lights are to appear equally bright. The light-adapted eye has its maximum sensitivity near 555 nm. (nanometer), while the dark-adapted eye is sensitive to no more than 505 nm.⁴ Accordingly, the green color of the spectrum (505 nm.) appears lighter when viewed with the dark-adapted eye, while yellow (555 nm.) appears to be brighter when viewed with the light-adapted eye⁵. This is because the pigments in the cones

¹R. G. Hopkinson, P. Petherbridge, I. Longmore: Daylighting, Heinemann, London, 1966, p. 1.

²Lloyd Kaufman: Sight and Mind, An Introduction to Perception, New York, Oxford University Press, London, Toronto, 1976, p. 84.

³*Ibid.*, p. 82.

⁴*Ibid.*, p. 85.

⁵*Ibid.*, p. 85.

and rods differ in their absorption to the wavelengths of light. A pigment is an absorbing substance found in rods and cones which has selective absorption to different wavelengths⁶, and those wavelengths that are not absorbed are reflected back again to the eye ball.

The rods (each 0.05 millimeters in diameter) that are responsible for vision in the dark are arranged in the retina so that the greater numbers of them are found as we leave the optic nerve⁷ and their pigment is called rhodopsin: it is sometimes called visual purple due to its purple color when it is in the dark. The rhodopsin absorbs more green than red or blue and this is the absorptive characteristic which accounts for the spectral sensitivity of the rods⁸. More absorption means bleaching of the rhodopsin until it becomes transparent and cannot absorb more light quanta⁹. This explains why the rods do not work in bright light. Rhodopsin regenerates in the dark and regains its maximum sensitivity after thirty minutes¹⁰. This explains why, when we enter a dark place, we cannot discriminate objects at once since the recovery of the rhodopsin takes place under weak bleaching light. If the light is neither weak nor strong, the regeneration rate will be equal to the bleaching rate and will thus cancel each other¹¹, a matter that affects the adaptation of the eye.

⁶Ibid., p. 86.

⁷I.E.S.: IES Lighting Handbook, First Edition, New York, 1947, pp. 2-5.

⁸Lloyd Kaufman: Sight and Mind, An Introduction to Perception, New York, Oxford University Press, London-Toronto, 1974, p. 86.

⁹Ibid., p. 88.

¹⁰Ibid., p. 89.

¹¹Ibid., p. 89.

The cones (each 0.32 millimeters in diameter), on the other hand, are not sensitive to weak light and they are excited only when each cone absorbs about five light quanta against one quantum for a rod (Brudley 1960). Thus the sensitivity to light at 505 nm. for the dark-adapted eye is about 100 times the sensitivity to light at 555 nm. for the light-adapted eye¹². Since the cones are concentrated in the fovea, and these cones are responsible for color discrimination, we may conclude that the sensitivity of the eye to colors is directional.

Not all the cones are sensitive to all colors, but there are several different types of cone-receptors sensitive to certain colors; each has its own pigment¹³. While some cones are sensitive to red, cones sensitive to green or blue may be slightly affected if the eye is subjected to red light alone. The green receptors for instance, can be excited to a certain amount by red light, but not as much as by green light¹⁴. Cones are the receptors that transmit color information to the brain by exciting different parts of the nervous system. Young postulated that there are three types of cones that are sensitive to red, green, and blue; all perceived colors are achieved by the activation of the cones in different amounts. This idea is called the trichromaticity hypothesis¹⁵.

¹²Ibid., p. 90.

¹³Ibid., p. 96.

¹⁴Ibid., p. 159.

¹⁵Ibid., pp. 159, 160.

¹⁶Ibid., pp. 176-177.

¹⁷Ibid., p. 177.

Some people may have only rods in their eyes. Since rods are more sensitive to yellow than red, red objects will appear darker to them than yellow ones, and the red light will be confused with a dim yellow light. These kind of people are called monochromat, or more commonly known as color blind.

When one type of cone is missing in the eye, the other two types of receptors will absorb some of the wavelengths of the missing one, because all pigments absorb all wavelengths, but in different amounts. The individual in this case matches any color with a mixture of two other wavelengths of color. If the pigment that absorbs green light is missing, the person is called deuteranope, even though he can discriminate green from certain combinations of red and blue on the basis of hue alone¹⁶.

People lacking one red light absorbing pigment are called protanopes, and they cannot detect the difference in brightness between a bright red and green light. Such people are insensitive to deep red light, because the remaining pigments have weak absorptive quality to deep red. If the deep red light is to be detected by a protanope, the intensity of such light must be increased so as to bleach both the green and blue pigments¹⁷.

Some people lack the blue light-absorbing pigment and are called tritanopia. In fact, in most people the blue light-absorbing pigments are few, and the blue light is confused with greens, whites and yellows which creates insensitivity to blue light (Willmer 1946 and Stiles

¹⁶Ibid., pp. 176-177.

¹⁷Ibid., p. 177.

1949)¹⁸. The lens and the part containing the fovea, which is yellowish in color, absorbs great quanta of blues. This explains why in an old eye, when the lens becomes yellow, the blue is hardly detected. Adding to these the relatively low absorption of the blue pigment to the different wavelengths, when compared to the absorption of the green or red pigments, we can understand why the eye finds it difficult to discriminate blue light¹⁹.

The spectrum of light reflected by a grey patch to the eye appears grey, but if this patch is surrounded by a red color, it appears greenish. The reason for this is that the response produced by red at a point in the retina inhibits the activity of red in another part of the retina. When the red wavelength is removed from a white light, the result is green light, as the effect of the green light is not affected by the absence of the red light. Blue and yellow light cancel each other because they compliment each other, and thus the mixture will look like green even though the other wavelengths are still present²⁰.

The appearance of colors are greatly influenced by the luminance of the surroundings. If an orange patch is surrounded by a white field of high luminance, the orange patch will appear brown. If the luminance of the surroundings is reduced, the orange color will appear lighter. This is attributed to the lateral inhibition which

¹⁸Ibid., p. 181.

¹⁹Kaufman: Sight and Mind, p. 191.

²⁰Ibid., p. 191.

produces this effect. With excessive brightness of the surroundings the effect of the patch on the central nervous system is reduced. This means that chromatic mechanisms are inhibited by luminosity mechanisms²¹. This can be interpreted in another way: when white light of high luminance enters the eye, some light is reflected into the eye ball, and this interreflection may influence the sensitivity of the eye to the patch. Accordingly, a white light surrounded by a white light which is higher in luminance will appear darker than if left alone, and vice versa. Since the two lights appear differently, there must appear a border between the two lights. If the two lights are of the same color, the boarder will not be easily defined, since the sensitivity of the eye is the same to both colors, but if the two lights are different in colors, the border will be perceptible. In this case, contrast can be observed, and this chromatic contrast enhances the effect of existing luminance contrast. The brightness differences might give rise to a perception of depth. Ittleson (1960) found that if two bright objects are viewed in a dark place, the brighter one will be perceived as nearer than the dimmer one²². Shades and tints of colors are also produced by contrast. An isolated object may change its brightness with the change of its luminance, but it should be viewed against a background light if it is to appear white or grey. We may conclude that the presence of black in a dominant field of white light increases the illumination, and

²¹Kaufman, Sight and Mind, p. 198.

²²Ibid., p. 224.

the luminance has a remarkable effect upon contrast sensitivity. Since such properties are perceived by the eye, it will be safe to indicate that the presence of different levels of illuminations and colors in the field of view increases acuity. Kaneko and Obonai (1957) proved that the absolute threshold of the light stimulus is increased with the presence of another light stimulus in another part of the visual field. This overestimation of light results from the fact that when a light stimulates one part of the retina, the retina cerebral nerve system is activated in the areas surrounding the stimulated part; this gives rise to perceptual properties²³.

The brightness of an object is dependent upon its surface reflectance, rather than upon illumination. The percentage of the light a surface reflects is its albedo²⁴. The texture of the surface determines its albedo, which is a physical property not available to perception. Helmholtz (1924) suggested that an observer can determine the reflectance of an object by comparing the illumination falling on the object with that reflected by it²⁵. This may explain why a white piece of paper appears white under different levels of illuminations, in spite of the fact that light entering the eye in each case is different in intensity. If the objects are to be seen easier by comparison, rather than by illumination, we can advance the

²³Toao Obonai: The Concept of Psycho-Physiological Induction, A Review of Experimental Work, Psychologia, 1957, p. 7.

²⁴Julian E. Hochberg: Perception, Copyright 1964 by Prentice-Hall, Inc., Englewood Cliff, N.J., p. 51.

²⁵Kaufman: Sight and Mind, 1974, p. 129.

idea that the visual field of the individual increases with time and space. Experience, learning, and culture must have their important weights in this respect. What we see is dependent upon our ability to contain the various cues in the surroundings and our speed in resolving them. Otherwise, discrimination between contours will be impossible. If it is unlikely that the visual field of the unexperienced eye is to be empty in the presence of the stimulus, we may suggest that the mind will exaggerate the sizes of the resolved objects in such a way as to fill the visual field. The periphery of such a field being neither resolved nor understood would appear hostile to the eye if it is to be the dominant factor in the field of view. Distal objects, if not containing complex cues to the eye, will be brought to the big picture. This may explain why a little child tries to catch the moon when he looks at it²⁶. Wickens and Meyer have shown that the image modifies in its travel through the two visual nerves and through the many synaptic stations between the eye and cortex. According to them, what really reaches the cortex from a viewed object is just a small part of it, and this part does not correspond to the reality of the thing, but it is zoomed inward in a distorted manner and shape. They illustrated it, showing that what actually reaches the cortex, when the eye looks at a human's face, looks like two cones with a black dot on each base²⁷.

²⁶Walter Gropius; Scope of Total Architecture, Collier Books, 1974, p. 33.

²⁷Delos D. Wickens, Donald R. Meyer; Psychology, The Dryden Press, Publishers, New York, July 1955, pp. 469-471.

Piaget's theory (1961) of Relative Centration postulates that the phenomenal size of an object, with reference to an external stimulus, is a direct function of the number of times it is centered by the sensory mechanism²⁸.

Wolfgang Kohler (1965) has reached a conclusion that equal distances and areas on the retina are not represented as equal distances and areas in the visual cortex²⁹. According to Brown (1953), the visually enlarged object is not complete in the cortex³⁰. Historical evidence has shown that, geometrical discrepancies between retinal sizes or shapes and their representation in the cortex can be presented in many parts of the field without the observer being aware of any distortion either in size or shape³¹.

The pupil of the eye responds to various light intensities; it contracts with increase in the intensity of light, and dilates when light fades down. This is the case when the level of illumination is stable, but the pupillary reflex to an increase in light is bidirectional, consisting of contraction followed by redilation. Lowenstein and Loewenfeld (1962), have shown that this happens in repeated phases and in short durations. The initial contraction begins with a latency of about 0.2 seconds, comprises a rapid primary contraction phase of about 0.6 seconds duration, and is followed by a secondary contraction with a slower duration of about 0.3 seconds.

²⁸Daniel Landis and Sylvia Harrison: Psychological Record, p.77.

²⁹Wolfgang Kohler: Unsolved Problems in the Field of Figural After-Effects, Psychological Record, 1965, p. 72.

³⁰Ibid., p. 72.

³¹Ibid., p. 79.

The opposite happens in the case of redilation; it is first rapid and then its speed diminishes. When the light stimulus is brief, such as when we glance at a window or when a glittering object crosses the visual field, this redilation restores the initial pupil size. If the increase in illumination is prolonged, the diameter of the pupil will be midway between the initial diameter and the pupil's extreme contraction. This happens to both eyes regardless as to which is stimulated. Though this reflex displays a general form, it is conditioned by the state of the observer because parasympathetic nerves originating in the Edingerwestphal nucleus are responsible for the action of the pupil³².

According to Loewenfeld (1966), all sensory stimuli dilate the pupil and only light can contract it. Also, Hess, et al (1965), reported that contraction responses are only due to visual stimuli³³. Sokolov (1963), indicated that on rare occasions, the pupil will dilate due to a sudden increase in illumination beyond the limit of normal light reflex³⁴.

Since the primary function of the pupil is to regulate the amount of light entering the eye, then it may be concluded that various humoral factors may exert inhibitory actions upon acuity. Woodmansee (1966) suggested a solution to this problem by keeping away from an object for at least three meters to minimize the difficulty

³²Brian C. Goldwater: Psychological Significance of Pupillary Movements, Psychological Bulletin, May 1972 Vol. 77, No. 5, pp. 340-355.

³³Ibid., p. 344.

³⁴Ibid., p. 344.

to maintain focus on the stimulus³⁵.

Holmes (1967) found that subjects who respond faster to light reflex are more aware of the contingencies in verbal conditioning tasks³⁶.

Since the diameter of the pupil ranges from 1.5 to 9 millimeters, and the emotional factors condition the dilation in the presence of light stimulus, then the best solution is to increase the level of illumination and to enhance contrast beyond the calculated standards so as to increase the ability of the pupil to constrict. This will result in a better seeing condition, because the focus and acuity will be improved simultaneously.

It is obvious that dilation increases with the increase in the excitation of the parasympathetic nerves which originate in the superior sympathetic ganglion (Edingerwestphal nucleus); thus we may suggest that the action of dilation is a result of nerve activity and after a period of time, leads to a condition of fatigue. This may explain the reason why the efficiency of performance under red light is greater than under green light³⁷. Accordingly, white light is the recommended light for prolonged task performance more than colored light. The environment in which the pupil is constricted most of the time is the most favorable one for production with lesser

³⁵Ibid., p. 343.

³⁶Ibid., p. 348.

³⁷A. T. Poffenberger; Principles of Applied Psychology, D. Appleton-Century Company Inc., New York, London, 1942, p. 155.

rate of fatigue. This can only be achieved by increasing the light intensity, and by minimizing the chance of the subject shifting his eyes to dimmer areas. This will lead to the assumption that shifting the eye to more illuminated areas while doing a task will be beneficial to the overall conditions for viewing and for visual comfort. This assumption may need support, but Arthur A. Eastman (1968) has reported that the visibility of a disc lighter than its background is less than if the disc were darker³⁸. He arrived at the conclusion that dark on light targets is more visible than light on dark targets with the same contrast value, with the condition that the contrast value must be very low. Hopkinson has indicated that glare discomfort is improved when the surroundings are bright³⁹. He also stated that some brilliance may be appreciated when it is not in excess and that uniformity of light may lead to fatigue and unpleasantness⁴⁰.

Pleasantness in an illuminated environment is governed by the relationship between the luminances rather than by their lighting quantities. The prolonged presence of a bright source of light in the field of vision will cause the light reaching the eye to scatter inside the eye ball which will result in a reduction of the sensitivity of the eye to contrast. When a very bright source is in a

³⁸A. A. Eastman: Color Contrast vs. Luminance Contrast, Illumination Engineering Society, vol. 63, 1968, p. 613.

³⁹R. G. Hopkinson: Daylighting, p. 324.

⁴⁰*Ibid.*, p. 301.

field of low luminance, the eye will find it difficult to discriminate objects in that field. This may be compensated for by increasing the luminance of the field. However, the luminance of that field, if increased beyond the adaptation limit of the eye, will result in discomfort glare. Discomfort glare may also be due to a very high contrast in the absence of luminance.

T. Obonai (1957) stated that the areas surrounding the stimulated part of the retina change their excitability when a light stimulates a part of the retina. This causes underestimation of perceptual properties such as sensitivity, brightness, color, spatial extent, etc., just after the cessation of stimulation. Gradually, with time, a process of overestimation occurs. It is only in areas remote from the stimulated part of the retina that underestimation occurs and becomes weaker with time⁴¹. Kaneko and Obonai proved that the presence of another light in the visual field raises the absolute threshold of the stimulus because the influence of the former works on the latter inhibitorily⁴².

K. Motobawa and M. Akita (1957) proved that electrical excitability of the retina undergoes changes when colored light is used for illumination. It rises to reach the maximum characteristics of the specific wavelength within a few seconds. For red light it reaches its maximum in one second; for yellow, 1.5 seconds; for green, two

⁴¹Toao Obonai: The Concept of Psycho-Physiological Induction, A Review of Experimental Work, *Psychologia*, 1957, p. 3.

⁴²*Ibid.*, p. 7.

seconds; and for blue light it is three seconds. This is a characteristic of the receptors in the retina and is not dependent on intensity, duration of the colored light, or on the area illuminated in the retina. When a colored light illuminates a certain area in the retina, a complementary color is formed around this area⁴³.

However, colored lights have different effects on man. They may induce indifference, melancholy, or may have a sedative effect and cause contemplation in him. Exciting colors are red, orange, yellow, and purple. The soothing colors include green, blue, indigo, and violet; pleasing colors include green, purple, and blue.

Commonly, red is associated with anger, warmth, and courage; blue with calmness; purple with stability and pomp. Yellow is associated with gaiety and warmth, and greenish-yellow, cowardness and disease.

The lighter or more saturated the color is, the more it connotes happiness and warmth. The darker and more saturated the color is, the more it connotes forcefulness. Greater brightness and greater saturation produce pleasantness, showiness, while greater saturation alone induces elegance. Hue is associated with excitement and elegance⁴⁴.

Although there is a general agreement that colors toward the

⁴³Koiti Motokawa and Munehira Akita: Electrophysiological Studies of the Field of Retinal Induction, Psychologia, 1957, p. 10.

⁴⁴Albert O. Halse: The Use of Color in Interiors, second edition McGraw-Hill Book Company, 1978, pp. 27-37.

red end of the spectrum appear to be nearer, and that colors toward the blue end appear to be farther away, experiments did not give evidence to such hypothesis, and the results were that colors in themselves do not have the quality of depth⁴⁵. However, artists have succeeded in their suggestion of the effect of color as indicative of distance. Accordingly, the responses of their students may be conditioned.

After experiments conducted by C. E. Ferree and G. Rand (1919) on the eye using different illuminants, it was found that when reading under different colored lights, the fatiguing effects and feelings of discomfort appeared to be dependent upon the characteristics of the specific wavelength⁴⁶. For instance, a feeling of discomfort under unsaturated yellow light appeared after 116 seconds with a loss of efficiency of 5.43 percent. For reddish-yellow, the loss of efficiency was 7.57 percent, and the feeling of discomfort occurred after 94 seconds. Reading under unsaturated yellow light with green added caused the fatiguing effect to appear after 48 seconds, and it is accompanied by a loss of efficiency of 24 percent. For greenish light it was 39.14 percent within 25 seconds, and for bluish-green it was 54.86 percent in just 14 seconds.

With regard to the effect of colored light on acuity, it was found that the colors toward the red end of the spectrum are more

⁴⁵Austin S. Edwards: Effect of Color on Visual Depth Perception, The Journal of General Psychology, 1955, 52, pp. 331-333.

⁴⁶A. T. Poffenberger: Principles of Applied Psychology, D. Appleton-Century Company Inc., New York, London, 1943, p. 156.

favorable to acuity than green. The values of red are from 20 percent to 50 percent above that of green. The values for blue are similar to green, but somewhat lower⁴⁷.

Sensations of color have intensity, saturation, and tonality. The intensity depends upon the quality of light. Saturation depends upon the relative purity of colors. Degrees of saturation are known as shades, and these shades can give rise to the sensation of depth. Tonality is the quality of the color on the scale of the spectrum.

Color contrast of more than 0.65 is of little importance to visibility regardless of the condition of colors. For instance, visibility of red on a neutral background is higher at a contrast of up to 0.15, while for green or blue, 0.30 contrast gives maximum visibility. For yellow, 0.10 contrast gives a high visibility level. Values of contrast above these ratios reduce the visibility of color contrast by less than 5 percent depending upon the color of the background. With a red background, all colors increase in visibility, more than when the background is grey, and the reduction of visibility due to an increase of contrast more than 0.50 will be about 2 percent. When the red background is replaced by yellow, the visibility levels of all colors varies less than 2 percent from the visibility of those on a neutral background when the contrast is about 0.40. When the color is lighter than its background, the visibility level becomes less than when the color is darker than the background⁴⁸. When the background

⁴⁷Ibid., p. 155

⁴⁸Arthur A. Eastman: Color Contrast vs. Luminance Contrast, Illumination Engineering Society, December 1968, pp. 617-618.

is moved backward from the color, the visibility level increases⁴⁹.

Color of light has an effect on the appearance of the object because differences in the spectral energy of light do not appear as differences in the color of light, but of the object itself. Every object reflects wavelengths with different proportions. If the light falling on the object is rich in the wavelength that the object also reflects more of, the object will appear to be more intense than the reverse, that is, when the wavelength is not rich in the wavelength reflected by the object, the appearance of the object is less intense. Also, the level of illumination contributes to the degree of such intensity⁵⁰. It is clear then, that light is modified before it reaches the eye. For example, on a day with a clear blue sky and in a room with a window facing a park, the light reaching an observer in the room is not that of daylight, but it is a mixture of colors that are reflected from the park, from the furnishings, and from the boundaries of the room. Some of the wavelengths may decay, while others are intensified according to the reflectivity of the objects and the surroundings, and according to the composition of light when it first fell on the object.

The color of objects as perceived are not only due to their reflective characteristics, as described above, but also due to their texture and surface finish. If the surface of the object is smooth, the reflection from such a surface may wipe out all colors, when viewed

⁴⁹ Ibid., p. 618.

⁵⁰ I. E. S.: Light and Color, Illumination Engineering Society August 1969, p. 516.

from a certain angle, and increase or darken the perceived colors when viewed from other angles.

The object appears natural only when its surface diffuses light in all directions. According to B. Judd and A. Eastman (1971), the color distribution of the image of the object in the retina differs from the spectral distribution as reflected from the object. They relate these attributes to the chromatic aberration⁵¹. They also showed that the addition of an external chromatic component may reduce the visibility level rather than increasing it. Chromatic aberration occurs because the eye's lens focuses each wavelength in different planes parallel to the retina. For instance, the eye has a longer focal length for red light than for blue light. In this case, the red will be focused in the retina, while the blue is cast as a blurred circle surrounding the red, when the image is formed on the retina. On the other hand, if the image is formed behind the retina, the blue will be in focus while the red will appear blurred with the blue in the center. Astigmatism may also contribute to the blurring of colors depending on the degree of distortion of the surface of the cornea and its shape. Still, Beck pointed out that accommodation could cause astigmatism for the nearer distant even if it could not be detected in the relaxed eye⁵². Campbell and Westheimer (1959) suggested that such chromatic aberration might be used by the observer as an information

⁵¹ I. E. S., Illumination Engineering Society, April 1971, p. 265.

⁵² Lloyd Kaufman: Sight and Mind, An Introduction to Visual Perception, University Press, London-Toronto, New York, Oxford 1974, p. 247.

code for depth perception⁵³. Kaufman (1974) stated that the iris constricts to reduce the bundle of light entering the eye to reduce the sizes of the blurred colors, and he related this to the activity of the cerebral cortex⁵⁴.

Eriksen and Halee (1955) have shown that color alone is not sufficient to give information to the observer, but color and shape can give information better and faster than color alone, if the light is intense⁵⁵. On the other hand, Smith and Thomas (1964) postulated that color is superior to shape at relatively lower levels⁵⁶. Both of these results were obtained from unstructured field experiments. Structuring the field may give different data according to the knowledge of the subject about the object. For instance, when we have knowledge about an object, any faint light can reveal it at once regardless of its color.

As colors become more and more distant they lose their intensity and appear bluish because the molecules suspended in the atmosphere inhibit the necessary amount of light reaching the eye. With distance, colors lose also contrast and accordingly their contours disappear, and hence they give no cues.

Adaptation of the eye to colors is a natural process which occurs though not noticed in our daily experience. If the retina is sub-

⁵³ Ibid., p. 249.

⁵⁴ Ibid., p. 247.

⁵⁵ Robert M. Slivka: The Psychological Record 1968, p. 544.

⁵⁶ Ibid., pp. 544-552.

jected to a color for a prolonged time, the color gradually tends to appear to be grey. The explanation for this phenomenon lies in the arousal of the antagonistic process involved in the maintenance of retinal experiences⁵⁷.

The visual systems of people in different countries are identical, but because ultraviolet radiation differs from location to location according to the altitude, increasing with altitude and with proximity to the equator, this excess in ultraviolet radiation causes an increase in the density of the yellow pigmentation at the cornea, the lens, the pigment epithelium, and at the macula lutea. This yellow pigment absorbs the short-wavelength radiation before it reaches the eye, and this results in a decrease in the spectral sensitivity of the eye to those wavelengths. This in turn, causes confusion of short-wavelength stimuli in color matching and color naming, and in rare cases, it decreases visual acuity. As a result, people confuse blue with green, or the reverse, or blue and green as being darker, or in extreme cases as being black, depending upon the interrelated factors. This case is mostly serious among the darkly pigmented peoples who confuse a great number of terms in more inclusive identities⁵⁸.

⁵⁷ Robert S. Woodworth, Harold Schlosberg: Experimental Psychology, Holt, Rinehart and Winston Inc., December 1965, pp. 428-454.

⁵⁸ Marc H. Bornstein: Color Vision and Color Naming, A Psychophysiological Hypothesis of Cultural Differences, Psychological Bulletin vol. 80, no. 4, October 1973, pp. 257-280.

ENVIRONMENTAL EFFECTS OF NATURAL LIGHT

Natural light produces many biological effects on man due to its photic energy and cyclic changes. The daily cycle of day and night serves to regulate and control the functions of the body, and the photic energy of natural light has an important impact on man's health and energy. The evidence is overwhelming that we should have every effort to admit natural light to our buildings, controlling it according to the body's capacity for adaptation and its physiological needs. The supporting evidence comes from the experiments and conclusions of the whole range of scientists, among whom are:

APPENDIX II

Dr. S. Martens suggested that the spectrum of light might influence the deterioration of eyes, tumor development, general health, rate of aging, and various physiological and psychological functions¹.

Pinna found that the hospitalizations of people in winter are less than in summer due to the deficit of the quantity of light and its ultraviolet component².

Dr. Weidert (1941) stated that the blood coagulation rate is faster in strong daylight due to the change in the number of white blood cells³. Also, experiments of Garon, Draffenberger, Marti, and Pinna showed that strong daylight increased the quantity of platelets in the body⁴.

Dr. Distenfeld proved that daylight is a very important factor in the regulation of the vital sys-

¹Richard J. Martens, Illumination Engineering Society, October 1968, p. 145.

²Henry L. Logan, The Relationship of Light to Health, Illumination Society, March 1947, p. 102.

³*Ibid.*, p. 162.

⁴*Ibid.*, p. 162.

BIOLOGICAL EFFECTS OF NATURAL LIGHT

Natural light produces many biological effects on man due to its photic energy and cyclic changes. The daily cycle of day and night serve to organize and control the functions of the body, and the photic energy of natural light has an important input on man's health and energy. The evidence is overwhelming that we should bend every effort to admit natural light to our buildings, controlling it according to the body's capacity for adaptation and its physiological needs. The supporting evidence comes from the experiments and conclusions of the widest range of scientists, among whom are:

Dr. R. Wartman suggested that the spectra of light might influence the determination of sex, tumor development, general health, rate of aging, and various physiological and psychological functions¹.

Finsen found that the hemoglobin of people in winter was less than in summer due to the decline of the quantity of light and its ultraviolet component².

Dr. Randot (1963) showed that the human organism is more active in strong daylight due to the change in the number of white blood cells³. Also, experiments of Oerum, Graffenberger, Marti, and Finsen showed that strong daylight increased the quantity of blood in the body⁴.

Dr. Pittendrigh proved that daylight is a very important factor in the regulation of the vital bio-

¹Richard J. Wartman: Illumination Engineering Society, October 1968, p. 528.

²Henry L. Logan: The Relationship of Light to Health, Illumination Society, March 1967, p. 162.

³Ibid., p. 162.

⁴Ibid., p. 162.

chemical actions in people by activating the genes that are responsible for the production of enzymes⁵.

Dr. Ott stated that the amount of ultraviolet visible and infrared radiation influence the biological functions in living things⁶.

Dr. Hardy stated that people pay a penalty for operating continuously outside the optimum range of natural light, and this penalty is the speeding of the aging process, which at the end, leads to a premature death. He showed through clinical evidence, the breakdown of tissues, capillary ruptures, impairment of circulation, kidney and heart muscle deterioration, and hypoxia⁷.

Dr. Dykman decided that a level of 2500 foot candles is the hygienic lighting level, and he demanded that light be more than that⁸.

Dr. Sheard postulated that with normal vision, the eye consumes 25 percent of the caloric intake in the process of seeing when illumination is sufficient. Any departure from sufficient light will result in great loss in the amount of calories needed for other bodily functions, and this will accelerate fatigue and subject the person to errors and accidents⁹. Henry L. Logan suggested that optimum daylight helps to eliminate phantom visual cues and reduces internal conflict, and provides a wealth of information, which is an important ecological factor in man's optimum environment¹⁰.

⁵ Ibid., p. 162.

⁶ Ibid., p. 162.

⁷ Ibid., p. 164.

⁸ Ibid., p. 164.

⁹ Ibid., p. 164.

¹⁰ Ibid., p. 164.

Dr. Ott (1965), based on experiments on the effect of wavelengths of light on physiological functions of plants and animals, suggested that the responses of the chloroplasts and pigment granules may be tuned to the natural light spectrum and that the intensity of the ultraviolet range is critical in the control of hormonal balance or body chemistry¹¹.

Dantsig reported a reduction in respiratory disease among 5000 school children after exposure to daylight¹². Zankova showed that improvement of responses to visual and auditory stimuli and resistance to fatigue was evident in children who were allowed to receive the daily natural light more than those who were denied it¹³.

Neer, at the Massachusetts General Hospital, reported that rickets could be related to the interior lighting environment. Looms also stated that rickets is a sunlight deficiency disease rather than a nutritional disease¹⁴.

Brownfield (1964) indicated that man requires not only stimulation, but also a variable and a continuous sensory input for the maintenance of normal adaptive behavior. Also, Scott, Bexton, Heron, and Doane (1959) confirmed the occurrence of hallucination under exposure to a prolonged period of reduced stimulation and decreased variation in the sensory environment, as was also suggested by Hebb (1949)¹⁵. Thus the movement of the clouds, the

¹¹ John N. Ott: Effect of Wavelengths of Light on Physiological Function of Plants and Animals, Illumination Engineering Society April 1965, p. 255.

¹² Luke Thornington, Louis Parascandola, and Lynn Cunningham: Visual and Biological Aspect of an Artificial Sunlight Illuminant, Illumination Engineering Society October 1971, p. 34.

¹³ *Ibid.*, p. 35.

¹⁴ *Ibid.*, p. 38.

¹⁵ A. Brownfield: Sensory Deprivation, A Comprehensive Survey, *Psychologia* 1964, pp. 63-93.

changing light of the day, and the condition of light in different days and seasons of the year are not only important for vision, but also for mental health and normal intelligent behavior. In this respect, Luckiesh said,

"Only by a blinding prejudice of an inexcusable egoism can man ignore the overpowering influence of sunlight and skylight".¹⁶

¹⁶ Luke Thornington: Visual and Biological Aspect of An Artificial Sunlight Illuminant, Illumination Engineering Society October 1971, p. 40.

DEFINITIONS UPON THE INFLUENCE
OF NATURAL LIGHT ON SPATIAL PATTERNS

Most of the material in this part is derived from observations and analyses of buildings from different periods. Unless otherwise indicated, the tentative conclusions are reached by the author, and hence, represent his point of view.

Artificial environments are created to provide shelter and protection from the unfavourable environmental forces that exert an influence upon the activity of man and his production.

Man has first decided to build a shelter for himself and his family, whether the idea of a shelter for the need for his presence

APPENDIX III

came to his mind. The reason is that his first building materials, wood or rock, permitted daylight to penetrate through the spaces between the building materials and through the entrance door, which was usually loosely covered with an animal skin. The natural form of shelter was his natural way of construction as the materials lent themselves to a system of tying the branches or beams together at the top.

The delight originated before the shelter, not because of the need for light, but as a solution to the necessity to release the smoke from the fire used for cooking or heating the enclosure. Smoke openings in the earliest phase of human existence were intended for

¹J. B. Ferriss, Primitive Architecture (U.S.), N.Y., 1933, p. 269.
See also Hildebrandt Architectural and E. W. Cresswell, Principles of Early Geography, 10 E. N.Y., Wiley 1930-32, p. 18.

REFLECTIONS UPON THE INFLUENCE
OF NATURAL LIGHT ON SPATIAL PATTERNS

Most of the material in this part is derived from observations and analyses of buildings from different periods. Unless otherwise indicated, the tentative conclusions are reached by the author, and hence, represent his point of view.

Artificial environments are created to provide shelter and protection from the unfavorable environmental forces that exert an influence upon the activity of man and his production.

When man first decided to build a shelter for himself and his family, neither the idea of a window nor the need for its presence came to his mind. The reason is that his first building materials, wood or reeds, permitted daylight to penetrate through the cracks between the building materials and through the entrance door, which was usually loosely covered with an animal skin. The conical form of shelter was his natural way of construction as the materials lent themselves to a system of tying the branches or reeds together at the top.

The skylight originated before the window, not because of the need for light, but as a solution to the necessity to release the smoke from the fire used for cooking¹ or heating the enclosure. Hence openings in the earliest phase of human existence were intended for

¹J. B. Ferree: Primitive Architecture (S.N.), N.Y. 1890, p. 149. See also Ellsworth Huntington and S. W. Cushing: Principles of Human Geography, Ed 3, N.Y., Willey 1920-24, p. 16.

circulation of air rather than for lighting per se.

Since cutting holes in the boundary walls would affect the stability of the construction, especially when it was made from earthy materials, the logical structural location of windows was probably in the upper part of the walls under the roof.

The quantity of light in the interior, then as now, was dependent upon the conditions of natural light and the size of the opening. These were controlled according to the functions required in the interior. For instance, in the ancient Egyptian architecture of temples, planning for the reduction of the amount of light was of vital necessity for the religious reasons of giving the place an air of mystery and gloom, as in the temples of Madinet Habu, where the windows were arranged in small slits. When light was needed to illuminate the core of the temple, as in the case of Karnak (1530-323 B.C.), the hypostyle hall was constructed with a clearestory so as to permit light to penetrate through pierced stone grills. In the temple of khons at Karnak (1198 B.C.), in a room east of the sanctuary, they introduced light through holes cut in the roof to dramatize the appearance of the statue of their god when viewed through a slit cut in the east wall of the sanctuary.

Another method of controlling natural light in temples is found in the temple of Hator (110 B.C.) and also in the temple of Hons. There in the portico, they erected screen partitions between the columns which were high enough to prevent veiling reflections from the arid desert while, at the same time, permitting skylight to pass freely over them.

In classical Greece, they devised a method to admit light in

accordance with the gradual distribution of natural light from the zenith to the horizon, by making the window narrower at the top than at the bottom².

In houses of the Hellenistic period, an open court served to illuminate the rooms arranged around it, while at the same time, providing shade within the court³. This introverted type is still in use in the Middle Eastern rural houses where street facades are provided with lattice work (mashrabiyehs) to shield the interior from sunlight without loss of privacy.

The vast vaults of the Romans received their light directly from the sky through segmental and semicircular headed windows located under the arches formed by the vaults, as seen in the Basilica of Maxentius (C. 300) or in the octagonal drum carrying the dome in S. Vitale at Ravenna (C. 567). The intention of the designers apparently was twofold, to provide their building with ample daylight, and to achieve aesthetic perfection by creating a well-lighted dominant central space, thus creating a focus of interest, and surrounding this by an ambulatory having subdued light to contrast the light in the central space.

In the spaces of early Byzantine buildings, such as that seen in Qasr Ibn Wardan, light was introduced through tiers of windows filled with thin perforated translucent marble or alabaster to cut the intensity of the brilliant sunshine.

² Peter Collins: Changing Ideals in Modern Architecture, (1750-1950), Faber and Faber, London, 1971, p. 90.

³ Vitruvius: The Ten Books on Architecture, translated by Morris Hicky Morgan, Dover Publications Inc., New York, 1960, pp. 185-189.

In the massive architecture of the Romanesque period, light was introduced through windows with receding sides and hence, helped to capture the maximum amount of light and to direct it to the interior. Light was also introduced to the nave through lunettes as seen in Durham Cathedral (1093 A.D.). These lunettes illuminated the cross-vaults and created different grades of lighting intensities, due to the shape of the crossvaults themselves, and their reaction to the incident light from the lunettes. This rhythm of light gave the place a dynamic quality and a restless allure. To enrich the quality of the light still more, a rose window pierced the west wall of the nave.

Because the intensity of daylight in western Europe is low and grey in color, the builders of the Medieval Cathedrals enlarged the windows to increase the illumination in the interior and filled them with stained glass to convert the grey light into colored light.

In Italy, because of the high intensity of light and also to give protection against the sun, the windows in the Gothic period remained smaller than in the north, as seen for example, in Santa Maria Donnaregina (1307), Santa Maria - Paiera del Carmini (1370), and Santi Giovanni e Paolo. When Gothic windows were used without consideration being given to natural light, they were either filled in with building materials, as happened at Segovia and Seville in Spain, or the quality of the stained glass itself changed, as happened in America. When the Americans began to use the stained glass windows to illuminate the interior of buildings, they found that the mixture of pure colors that resulted was not the same as in Europe. This was because the light penetrating the antique glass is excessively intense for the thickness of that glass. In an attempt to obscure the light, they introduced

what is called opalescent glass⁴. The result was fairly good and a soft color could be obtained, but in overcast sky conditions, the interior appeared dull. To solve this problem, the artists tried to arrange the plates so as to create tones which enhance the value of light by benefiting from the radiation of certain transparent colors. Another solution found was the painting of antique stained glass not in tones or masses, but rather in spots or lines to gain vitality in depth and richness of color, as well as an atmosphere of intensified light⁵. However, this was only valid within a reasonable range of light.

In France and England the light is not as intense as in southern Europe. Because medieval stained glass varied in the thickness, it produced colored light with varied luster, creating a more tolerable, interesting, and even delightful environment there.

With the invention of printing during the Renaissance period, and with the increasing number of people using their eyes for reading and writing, it became necessary to increase the amount of light necessary for the task. Thus we see in the Renaissance period that the residential windows increased in size, and the interiors became lighter. Alberti adopted the corpuscular theory of light and disregarded both the Pythagorians and Platonists⁶. The result was an architecture depending on its lighting upon direct lines from the sky to the task.

⁴ George Herbertson Charles: Stained and Painted Glass, American Churches, vol. I, The American Architect, New York, 1915, pp. 67-83.

⁵ Ibid., pp. 77-83.

⁶ Joan Gadol: Leon Battista Alberti, Universal Man of the Early Renaissance, The University of Chicago Press, Chicago and London, 1973, p. 29.

Windows took rectangular shapes with emphasis on the patch of sky seen from the interior. We can see the reflection of this in Alberti's Palazzo Rucellai (1446) in Florence. There the windows were rectangular and tall. In the ground floor, windows were located near the ceiling to serve two purposes, to admit light from the sky, and for defense purposes. He depended on the hinged wooden shutters to control light and protect the interior from it on sunny days.

Unlike Alberti's, Palladio's buildings usually relied on light reflected from different surfaces rather than directly from the sky. He used porticos, arcades, and other appendages to shield the building from direct sky light. Examples of these are the Villa Saraceno at Finale, Villa Sarego at Santa Sofia di Pedemonte, and Palazzo Chiericati at Vicenza.

However, in the Renaissance period, the compulsion toward symmetry caused the openings to be relatively equal in size and appearance regardless of room size or function, a matter which led to an excess of light in some places and a lack of it in some others. Examples of this include Palazzo Farnese by Antonio da San Gallo the Younger in Rome (1534), Palazzo Massimi alle Colone by Peruzzi (1535) in Rome and the Uffizi by Vasari (1560) in Florence. In the Palazzo Farnese, small rooms have more windows than big, rectangular rooms, and when Michelangelo built the top story in 1548, he increased the height of the window sills without affecting the window sizes. The result was an increase in the penetration of light into the remote parts of the rooms without changing the number of windows or locations. In the Palazzo Massimi, by Baldassare Peruzzi, some windows remained in deep shadow, while others were left unprotected. The deep darkness

of the ground floor was not balanced with the lightness of the upper floors, though the function did not change. The two latter examples reveal that the concern was more directed toward the artistic appearance of the building rather than upon the illumination itself. Vasari did the same in his Uffizi, but retained the expression of power and solidity, which had characterized the Renaissance style since its founding.

I surveyed the free hand sketches and the buildings of both Michelangelo and Guarini to see how they manipulated their architectural spaces to accommodate lighting. Michelangelo used light as a photographer would. He ingeniously synthesized his ideas to create the composition of the sculpture and the way it might appear under a certain direction of light. He then used architecture not as a space for the promotion of life, but first of all, as a background to his compositions.

Guarini on the other hand, was preoccupied with the invention of new geometrical forms beginning with a rectangular base. When he discovered that this will not lead to a new form, he dispensed of the straight lines. His negation of the straight line drove him intentionally or unintentionally to the cult of the curve. Unlike the straight line, the curve cannot be a measure of the shortest distance between two points. When the eye looks at a pattern of dots, it tries to draw lines to determine the figure. If a comprehensive figure cannot be obtained in such a way, the mind rejects the whole pattern and determines it to be either meaningless or judges the dots themselves to represent the surface texture of the pattern itself. Light rays behave in the same way. When a ray falls upon an object, it leaves

the surface in a straight line in a direction which depends upon the angle of incidence and the reflective characteristics of the surface. Guarini, by his adoption of the undulating surfaces, created infinite possibilities from the reflecting surfaces causing the light to reverberate within the enclosure. The same principles applied to the exterior of his buildings. This reverberation of light produced infinite image fantasies accompanied by huge amounts of visible chaos. Surfaces which were originally attached to the composition appeared to be detached under the overwhelming power of the sharp contrasts. Light that was supposed to fall on objects was directed to the observers. Contours that were supposed to be clarified by light were corroded by it. In short, a battle between mass and light was meant essentially to draw the attention of people from the outside, and once they were inside, they were pulled forcibly to a predetermined direction. Thus Guarini succeeded in moving people through the play of light and mass as may be seen in his Chiesa de S. Anna, S. Maria della Divina in the province of Libona and S. Fillippo Neri at Torrini.

However, it should be mentioned that people were not drawn against their wills into such an atmosphere in which gravity was denied through the skillfull manipulation of light. One may say that light moved people by its power of transforming the place from a mathematical and epistemological space into a void in which vision was set free to wonder beyond the corporeality of the elements, while the body movement itself was permitted only to extend in a predetermined direction, controlled and governed by the rhythmical expansion of the void within the interior of the building.

Thus the Baroque designer employed light not only as a tool to clarify the objects in space, but also as a medium to produce psychedelic effects on the observer, transporting him from the real world in which he lives, to an unknown world perceived only by architects and painters.

Borromini and Bernini in their completion of Palazzo Barberini, which was begun by Maderna (1628), splayed the window reveals to the exterior, as seen in the upper floor. This caused an increase in the amount of light inside the room as was demonstrated experimentally by the author in another part of this thesis. However, Bernini's intention was to employ light to produce the effect of depth rather than to admit direct lateral illumination, as seen in his design of the Scala Regia in the Vatican Palace in Rome (1663) and in the arrangement of the colonnades in St. Peter's Square (1656).

Narciso Tome devised a new method of capturing light through a vertical plane and then flooding it upon a horizontal plane via the gradually curved ceiling. This bending of the direction of light could be seen in the Toledo Cathedral, which was completed by Narciso in 1732 and which was originally a thirteenth century French Gothic building⁷. Narciso took out the masonry of half a Gothic vault of the ambulatory, and built a dormer-like shape over it to light the angle located in the opening cut in the vault from behind⁸.

⁷ Nikolaus Pevsner: An Outline of European Architecture, Butler and Tanner Ltd., Frome and London 1975, Penguin books, p. 255.

⁸ Ibid., p. 258.

From the variety of the influences of natural light upon the architecture of past epochs, and from the different possibilities presented thus far, one might expect that the solutions that might be brought into architecture during its evolutions would be influenced by these former methods. What was not expected, and unfortunately happened, was that solutions meant for certain conditions of light were applied in places with different intensities of light and magnitude. The reason for this was not due to lack of ideas but rather due to needs other than light. These needs were ethical and aesthetic and were related to what was called "Romanticism" and not to the need of light itself. Nevertheless, there appeared some innovations for the introduction of light into the interior. One of these was the bay window, which became a common feature in the architecture of England in the eighteenth and nineteenth centuries as a response to the characteristic dull light in that country. The effect of the bay window was to produce a pool of light near the window. This arrangement produced good illumination in a space in which different visual activities could be carried on with ease and comfort. This method of lighting was applied extensively in American rural and urban buildings.

Until the twentieth century, the numerous mullions needed to hold the many small panes of glass reduced the amount of light entering the room. Furthermore, the mullions silhouetted against the brilliance of the light from outside produced eye strain in the observer. To reduce the contrast, the mullions were commonly painted white. In France, they introduced what was referred to as "the croise window"⁹.

⁹Harold Edward Beckett: Windows: Performance Design and Installation, RIBA Publication, 1974.

This window was composed of a rectangular opening having a height equal to the floor height minus the beam depth, and was screened with louvered shutters. The balconies in front had a balustrade of simple iron work so as not to obstruct the light from the lower part of the window. This arrangement permitted good control over the condition of light. In summertime for instance, the louvered shutters hinged from the sides could be changed in a direction to prevent direct sunlight from penetrating the interior, and the horizontal slats of the shutters themselves could be directed either to receive the light from the sky or from the opposite planes, according to the amount of light needed in the interior. This system was adopted and still is in common use in the architecture of the Mediterranean zone and the Middle Eastern countries, as this method has proved its merits in locations where daylight is intense and overcast sky seldom occurs.

Early in the twentieth century, developments moved in the direction of openness. The trend was toward the creation of an international style. This style was exemplified by the work of Gropius, Mies van der Rohe, Le Corbusier, and others. In the early work of Gropius, he removed all constructional obstacles from the facades of his buildings that would obstruct the penetration of daylight. In his Fagus Works at Alfeld near Hannover, in 1911, he made glass windows at the corners without mullions or supports. His office building, which was erected in Cologne in 1914, appeared as if the wall and the window were synonymous, and even the two stairs were put inside curved glass towers so that the skeleton and the interior became exposed to direct sunlight.

Le Corbusier on the other hand, manipulated light in such a way

as to express its modeling effect upon simple geometrical forms. He was concerned with the cycles of the day, the differing seasonal movements of the sun, with respect to a building and the color of objects under natural light and their effects on the psychology of man, according to his culture and understanding. He also used brisesoleil to protect the building from direct sunlight and from undesirable reflections. He introduced the horizontal strip window to occupy the whole span between supports defending it as superior to the tall window, with respect to the amount of light, provided that both are of equal size¹⁰. In this respect Le Corbusier wrote, "Awkward vertical windows are (therefore) redundant and with them, the ugly window mullions and supports. Consequently, rooms are lit evenly from wall to wall. Experimental research has proved that a room illuminated in this way is eight times higher in light intensity than a similar one with the same area of vertical window."¹¹ In fact, he actually underestimated the tall window. Experiments conducted at the University of Pennsylvania by this author did not give any support to his conclusions, but rather proved in many ways that the tall window gives more light and better penetration than a horizontal window of the same size.

Unlike Le Corbusier, Mies was not interested in the pictorial shape of the building as seen under natural light, instead he was

¹⁰Tim and Charlotte Benton with Dennis Sharp (ed): Architecture and Design 1890-1939; The Whitney Library of Design, An Imprint of Watson-Guptill Publications, New York, 1975, p. 155.

¹¹*Ibid.*, p. 155.

concerned with the effect of light in clarifying a space, and with its imaginative effects which give meaning and order to the relationship between the parts of the structure. He regarded light as having a universal character not confined to any age or style. He believed in creating a lasting quality for a building which would exceed the temporary existence of man. Thus he was dealing with natural light for its significance to the spiritual needs of man, rather than its actual effects on his visual tasks. The result is, as we observe in most of his works, that the building stands with its exterior skeleton unchanged while changes take place in the interior. Pure, unobstructed, and unmodified light penetrates it from all sides. There is less skin, more light.

Unlike Meis, Wright regarded natural light to be ambient light associated with heat. Most of the openings of his buildings are shielded from direct light either by sheds or by daring cantilevers in the form of vast balconies. When he introduced skylights, he provided a contrast to its brilliant light. In the Johnson Wax Building, for example, the mushroom shaped columns, which were supported laterally at the sides and pinned at the bottom, served to protect the working area from the brilliant light of the skylight above. In the Guggenheim museum in New York, though he covered the interior with a skylight dome made of glass, he did not use it to illuminate working areas.

Wright explained the sheds located directly over the window heads as being efficient in increasing the amount of light penetrating the room because light, after falling on the bottom surface

of the horizontal sheds, would be reflected to the window, thus adding to the total amount of light entering the room¹². Scientific analysis has shown this to be true in some respects, but false in other respects. Since the sky is the main source of illumination, the intensity of light is higher near the window opening than in the remote areas of the room. Thus a curve representing the distribution of the intensity of light in a section perpendicular to the window will have its peak near the window and gradually declines until it reaches a very low level of illumination near the back wall. The observer in such a room perceives the light to be bright near the window and to be dark on the opposite wall, regardless of the actual level of illumination in that darkly perceived area. When Wright introduced the horizontal shed, what really happened was that he flattened the above mentioned curve and hence the eye changed its adaptation level and sensed an improvement in the lighting of the place. The shed cut a portion of the light that was formerly received near the window, and thus the intensity of light was reduced not only in that area, but also over the whole room. The shed, being lit by light reflected to it from the external planes and ground reflected it back to the rear portion of the room, and not to the area directly near the window. Since the observer is not allowed to compare the difference between the two lights, he will judge the latter as being lighter, influenced by the phenomena of simultaneous contrast.

¹²Fim and Charlotte Benton with Dennis Sharp (ed): Architecture and Design 1890-1939, Watson-Guptill Publications, 1975, p. 63.

Similarly, Le Corbusier played the same trick in the Ronchamp in that he pierced the walls with different window sizes. Such an arrangement could cause serious glare discomfort if they were left without splaying their reveals to the interior. The gradual transition of light from the windows to the surrounding walls caused the wall to appear lighter.

Louis Kahn regarded natural light as an important parameter which gives character to the building, and it should open to receive that light evoking the unexpected in its appreciation. He felt natural light gives different moods to rooms. A room receiving light from the north and west side must have a different character from one receiving light from the south and east, and so on. The window which is designed for one light orientation will not be identical to that of the other. Each room must have its own kind of light so that if one goes to that room at a certain time of day, his memory will tell him what effects to expect there. Kahn considered this an opportunity for light to reveal its characteristics¹³. Thus hiding the structure would mean loss of the opportunity to introduce the benefits of natural light. He was totally against a room which depends on artificial light and considered it unworthy to even be called a room. Instead, the inner room would have to have a break

¹³John W. Cook and Heinrich Klotz: Conversations With Architects, Praeger Publishers, New York, 1973, pp. 212,213

in the ceiling to receive the natural light. An example of this can be seen in the dormitories at Bryn Mawr. In Kahn's opinion, the structure which gives light to the room individualizes it. He used deep window reveals to reduce the effect of glare, as can be seen in the Rochester Synagogue; he felt this was desired by the window itself. Above the exterior, he made four hoods arranged about the corners of the central meeting place. These hoods rise up to receive light from the sky and pour it down into the room.

Kahn felt the plan of a building was to an architect what a sheet of music was to a musician. Such a plan should read like a harmony of spaces in light. He suggested that even if a space is intended to be dark, it should have just enough light from some mysterious opening to tell the observer how dark it really is¹⁴.

Kahn found it important that each window should face a free wall and that such a window must open to the sky enough to receive the maximum light. The glare which may result could be modified by the reflections coming from the lighted wall facing that window.

Kahn opposed the skylight with brise-soleil¹⁵ as it fragments the sky producing an aesthetically offensive appearance. At the same time, he never used brise-soleil to protect the building from the sun as Le Corbusier had in the apartment buildings of Marseille. Instead he used porches composed of walls with circular openings as sun screens. Such walls aided in reflecting the light which cut the

¹⁴Ibid., pp. 214, 215.

¹⁵Ibid., p. 198.

glare coming from the openings.

The contemporary buildings could have benefited from the experiences and the examples presented thus far. Unfortunately, the current trend is toward the use of artificial light in buildings, with architects neglecting the important characteristics of natural light. Buildings are designed as though we are continuously living in the dark of night. In such buildings, one is not aware of the time of day, nor of the changes of the seasons. As we have seen before, there is a physical and psychological danger when we are deprived of the natural environment in which natural light is most important. Artificial light can never equal natural light. Heat radiated from light fixtures can exceed the amount of heat accompanying natural light having the same wattage, thus disfavoring its use. It becomes clear, then, that lighting should be modified in such a way as to produce the maximum benefits, especially as not only the feeling of well being of the occupant is improved, but also much of the costs are reduced that are spent in illuminating spaces continuously that are not in actual use most of the time.

From Figures 43, 44, 45, we can see that:

The window with the external reveal (Figure 43) produces a better distribution of light on the work plane. The influence of the beam is significant, which suggests that it reflects additional light to the ceiling in the case of a plane perpendicular to the window.

The window with the internal reveal (Figure 44), admits the lowest percentage of light but has the advantage of an improved distribution of light in the wall surrounding the window. In this particular case, ground reflections have an insignificant effect of lighting.

APPENDIX IV

The window with a square reveal introduces greater illuminance near the center than that produced from the other two types of windows, but this increase is hardly significant. For instance, at reference points 41 and 42 (Figure 44), this window introduced six times as much as that introduced by the window with the internal reveal, while the window with external reveal introduced five and a half times that introduced by the latter. At all other reference points, the window with external reveal is superior especially near the rear wall. At reference points 43 and 44, the window with square and external reveal introduced respectively, about three and four times as much light as the window with square reveal are located to the interior.

Comparative Analysis Of Rooms, Being 1.20 x 1.30 Meters Measured Internally, Located In The Middle Of The Room, Employing Natural Light.

From Figures 43, 44, 45, we note that:

- . The window with the external reveal Figure 45, produces a better distribution of light on the work plane. The influence of the lawn is significant, which suggests that it reflects additional light to the ceiling in the case of a plane perpendicular to the window.
- . The window with the internal reveal Figure 43, admits the lowest percentage of light but has the advantage of an improved gradation of light in the wall surrounding the window. In this particular case, ground reflections have an insignificant effect of lighting.
- . The window with a square reveal introduces greater illumination near the window than that produced from the other two types of windows, but this increase is hardly significant. For instance, at reference points AI and BI (Figure 44), this window introduced six times as much as that introduced by the window with the internal reveal, while the window with external reveal introduced five and a half times that introduced by the latter. At all other reference points, the window with external reveal is superior especially near the rear wall. At reference points AIII and BIII, the window with square and external reveal introduced respectively, about three and four times as much light as the window whose reveals are bevelled to the interior.

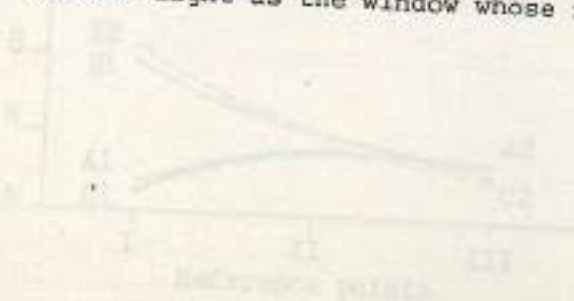

Room = 4.00 x 3.50 x 2.75 m.

Window = 1.20 x 1.30 m.

Sill = 0.90 m.

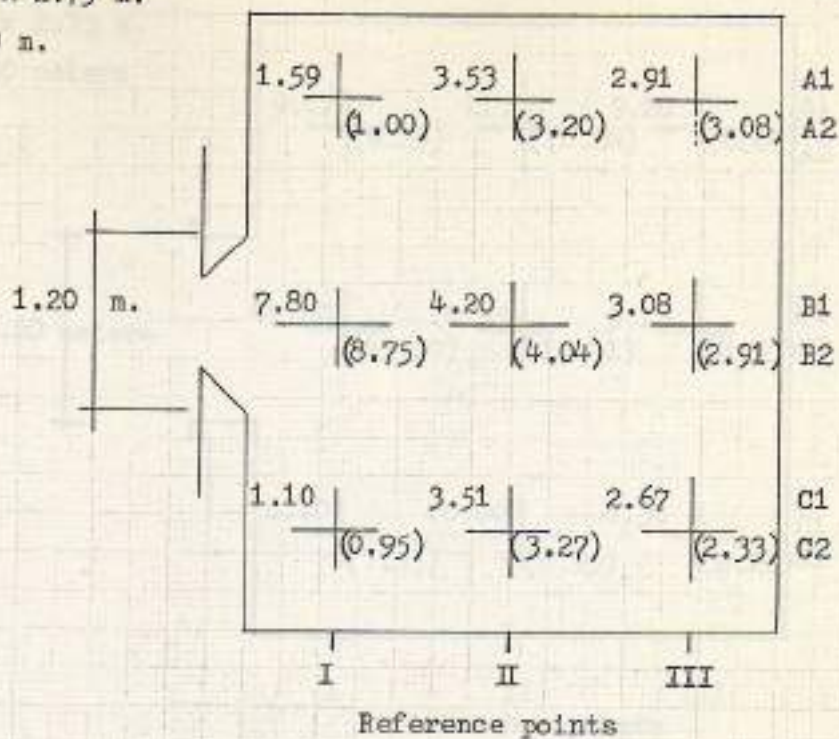

Plan 1:50

Light source = NATURAL

Readings = On work plane

----- = Model on lawn

————— = Model on concrete

N.B. Numbers between brackets represents percentage of light received at reference points in the case when the Model was put on lawn

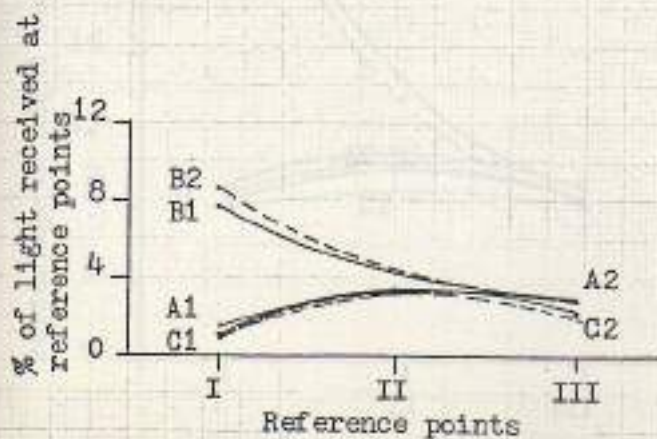
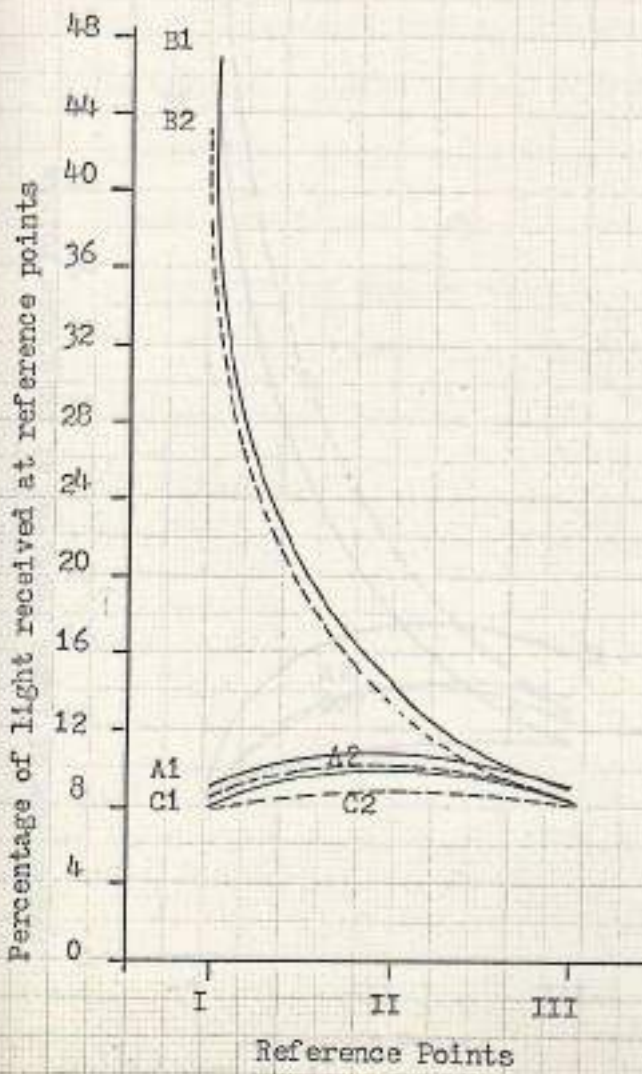
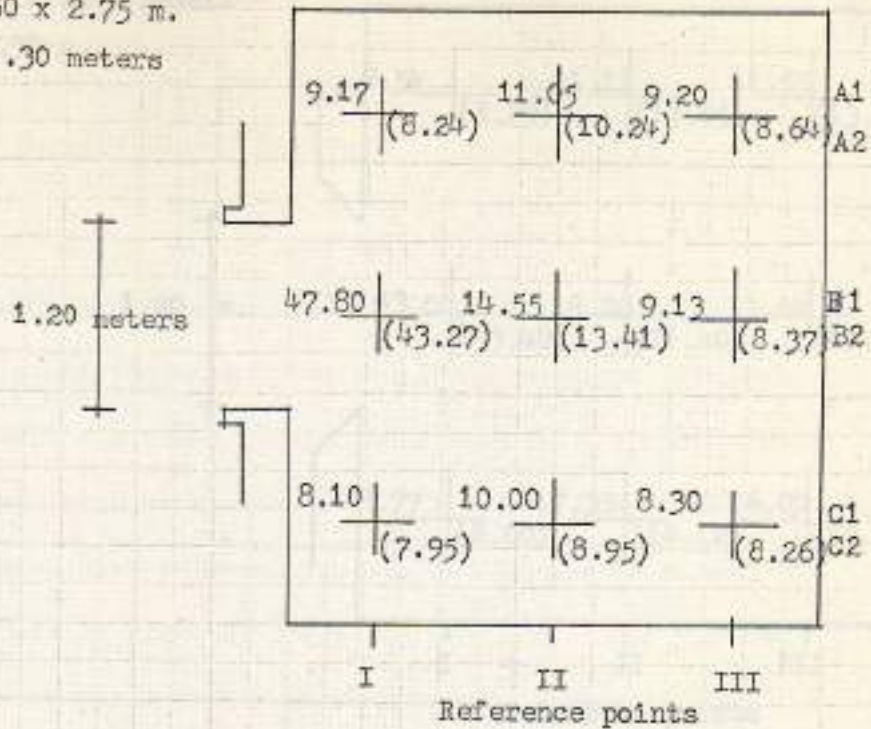

Fig. 43 Performance of window 1.20 x 1.30 meters with reveals beveled to the interior

Room = 4.00 x 3.50 x 2.75 m.
 Window = 1.20 x 1.30 meters
 Sill = 0.90 m.



Plan 1:50
 Light source = NATURAL
 Readings = Work plane
 ----- = Model on lawn
 _____ = Model on concrete

Fig. 44 Performance of window 1.20 x 1.30 Meters with square reveals.

1 Cm. = 0.5 m.

Room = 4.00 x 3.50 x 2.75 meters

Window = 1.20 x 1.30 m.

Sill = 0.90 m.

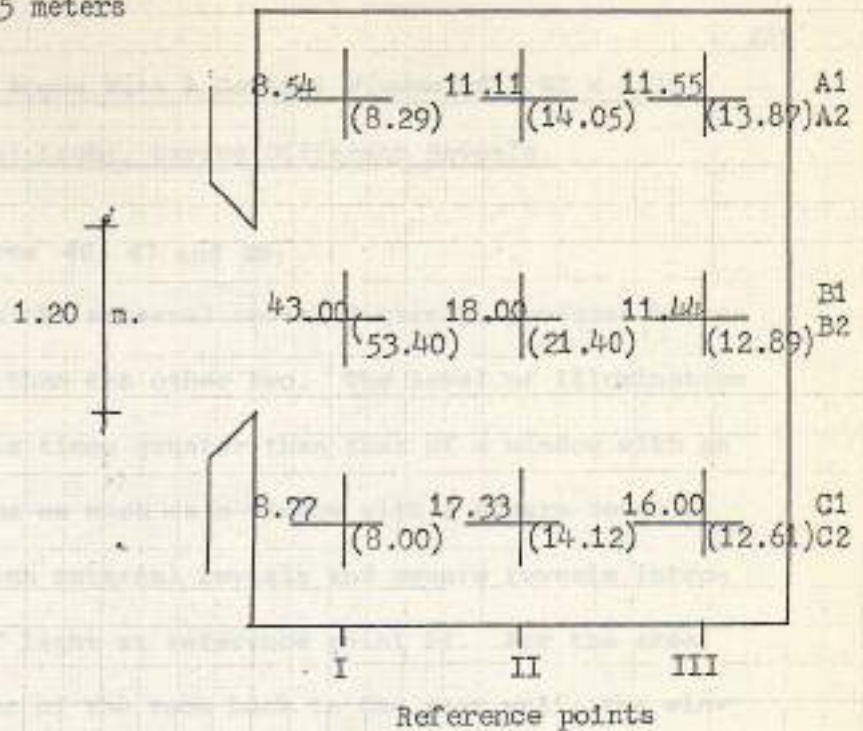

Light source = NATURAL

Readings = Work plane

----- = Model on lawn

————— = Model on concrete

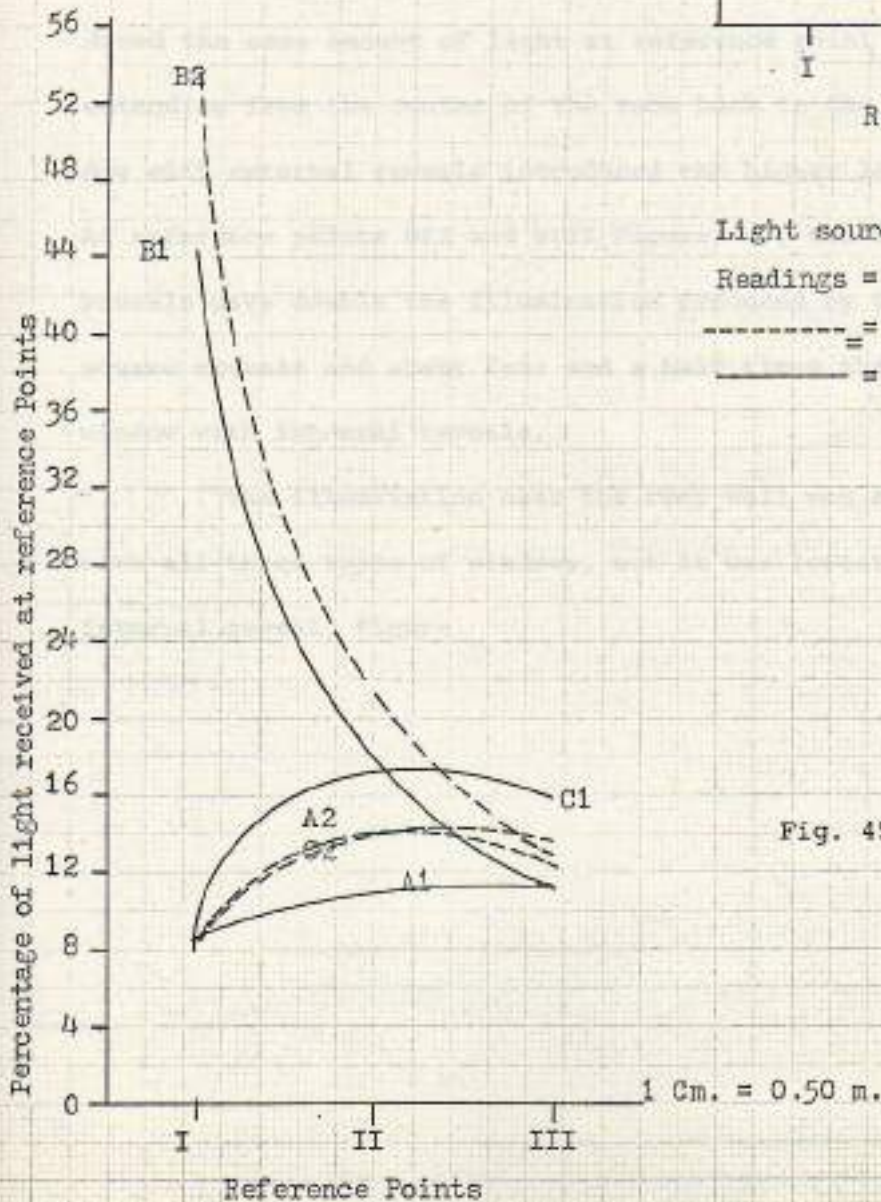

Fig. 45 Performance of window 1.20 x 1.30 Meters with reveals beveled to the exterior.

Comparative Analysis Of Rooms With A Central Window Of 1.80 x 1.30 Meters, Employing Natural Light, Having Different Reveals.

As shown in Figures 46, 47 and 48:

. The window with the external reveal Figure 48 produces better light at the work plane than the other two. The level of illumination at AI and CI is about six times greater than that of a window with an internal reveal and twice as much as a window with a square reveal.

. Both windows with external reveals and square reveals introduced the same amount of light at reference point BI. For the area extending from the center of the room back to the rear wall, the window with external reveals introduced the higher levels of illumination. At reference points BII and BIII Figure 48, the window with external reveals gave double the illumination produced by the window with square reveals and about four and a half times that produced by the window with internal reveals.

. The illumination near the rear wall was evenly distributed with all three types of windows, but it was lowest in the case of the internal reveal, Figure

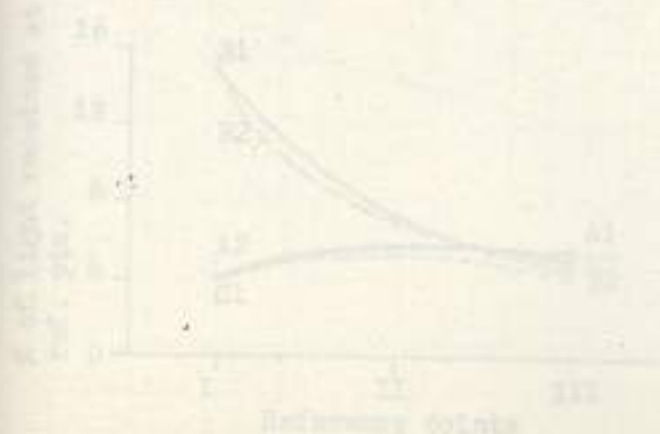
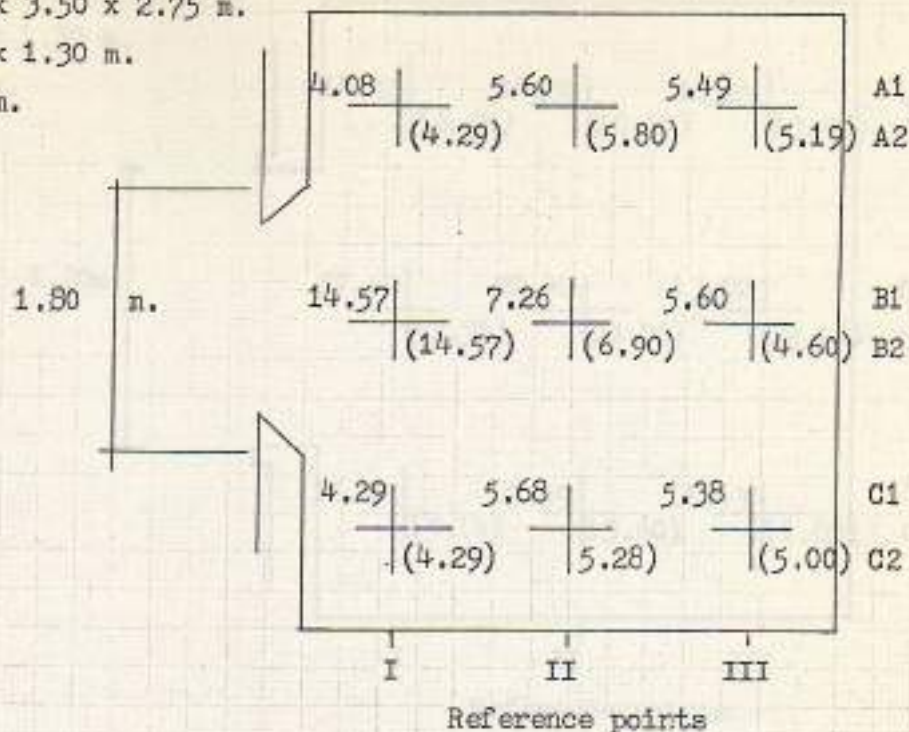

Fig. 46. Arrangement of window 1.80 x 1.30 meters with reveals located on the interior

Room = 4.00 x 3.50 x 2.75 m.

Window = 1.80 x 1.30 m.

Sill = 0.90 m.



Plan 1:50

Light source = NATURAL
 Readings = On work plane
 ----- = Model on Lawn
 _____ = Model on concrete

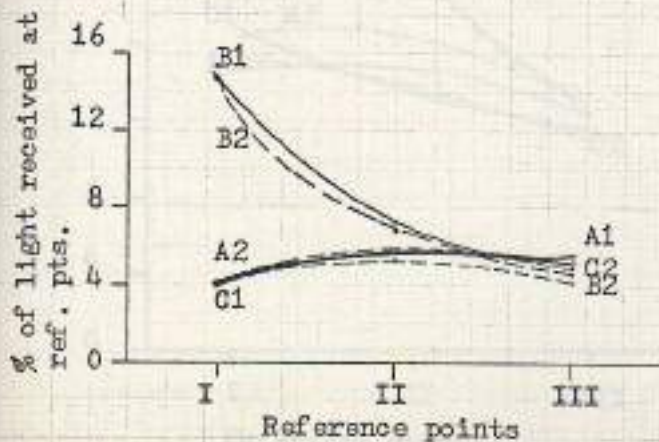
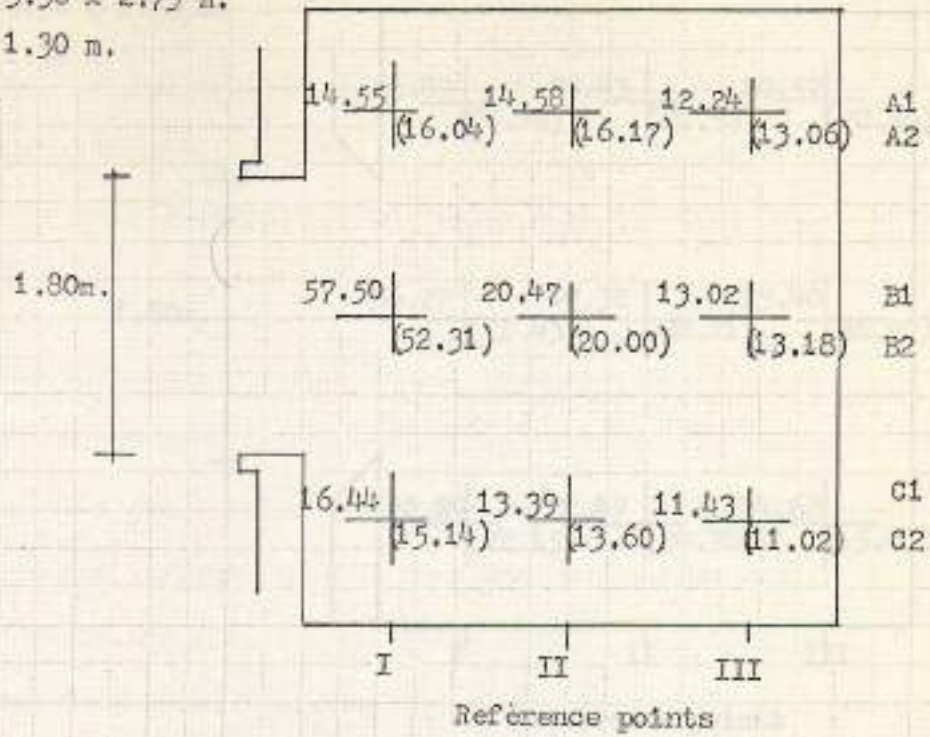

Fig. 46 Performance of window 1.80 x 1.30 meters with reveals beveled to the interior

Room = 4.00 x 3.50 x 2.75 m.
 Window = 1.80 x 1.30 m.
 Sill = 0.90 m.



Reference points
 Plan 1:50

Light source = NATURAL
 Readings = On work plane
 ----- = Model on lawn
 _____ = Model on concrete

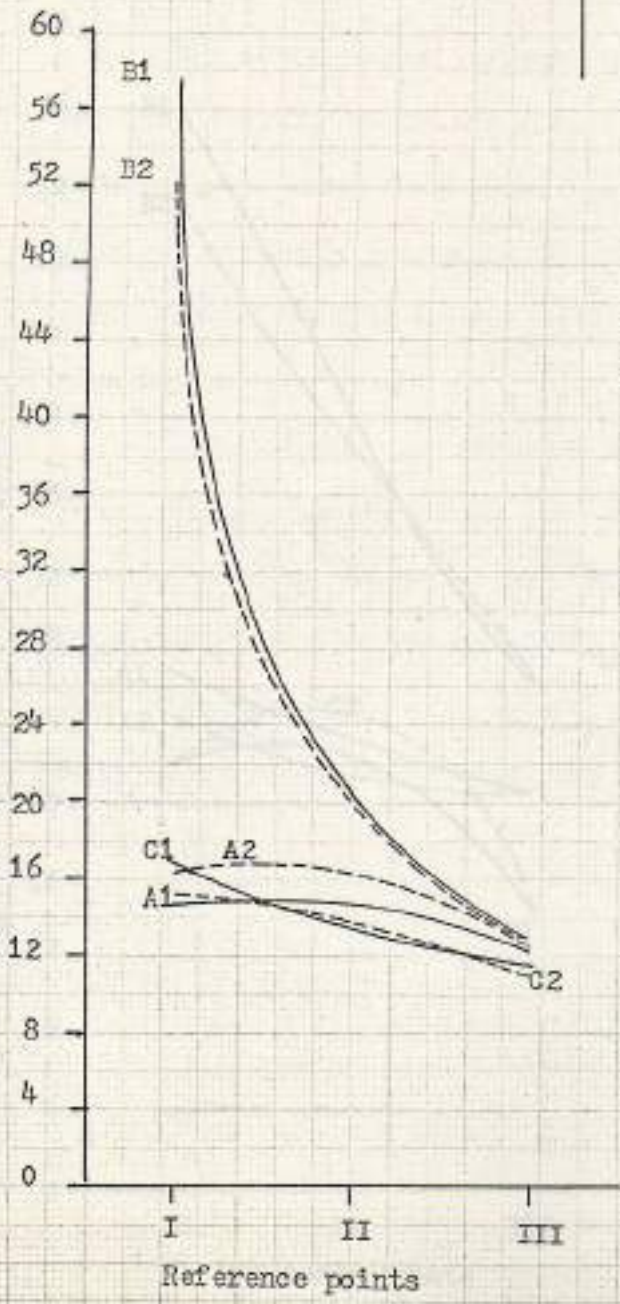
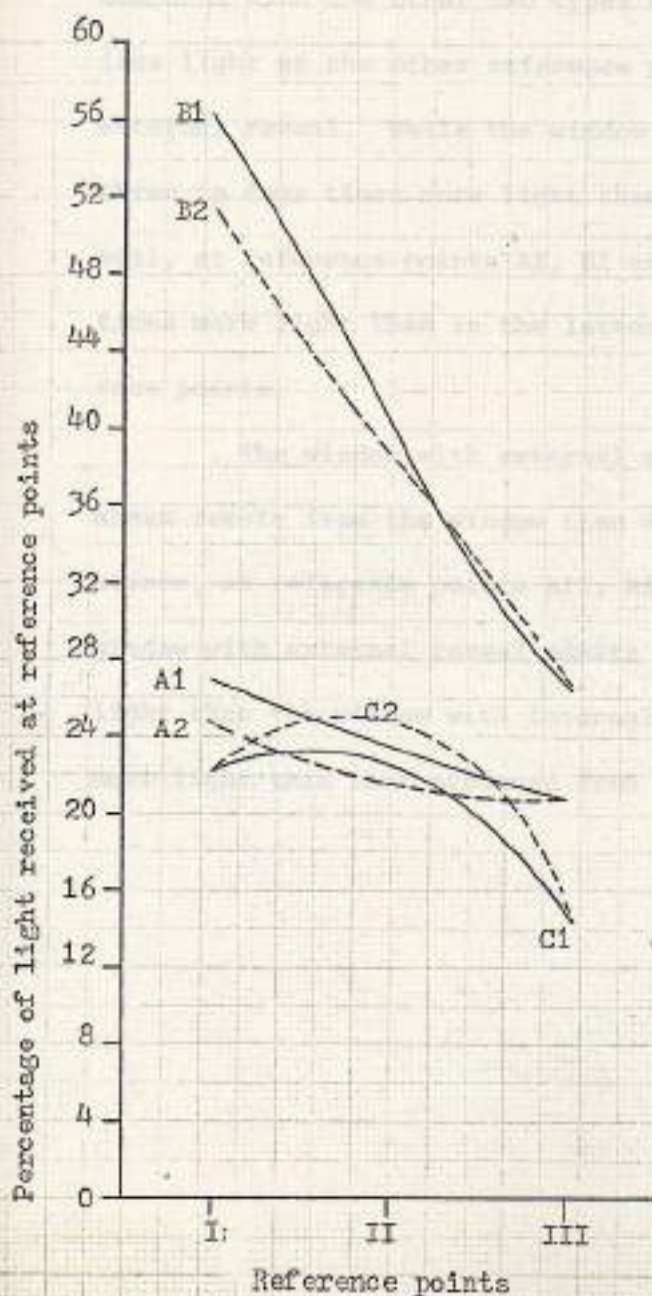
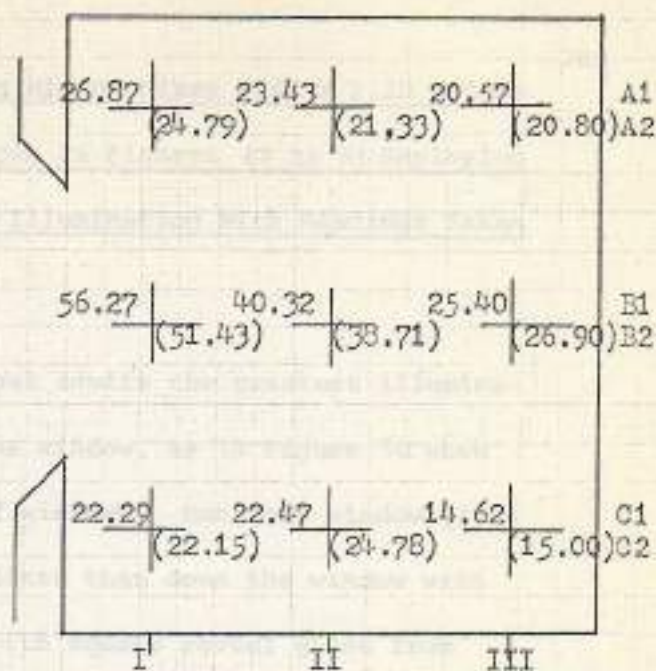

Fig. 47 Performance of window 1.80 x 1.30 Meters with square reveals

Room = 4.00 x 3.50 x 2.75 m.

Window = 1.80 x 1.30 m.

Sill = 0.90 m.



Reference points

Plan 1:50

Light source = NATURAL

Readings = On work plane

----- = Model on lawn

———— = Model on concrete

Fig. 48 Performance of window 1.80 x 1.30 Meters with reveals beveled to the interior.

Comparative Analysis Of Rooms Having Window Sizes 2.40 x 1.30 Meters
With Different Reveal Shapes, As Shown In Figures 49 to 51 Employing
Natural Light As The Main Source Of Illumination With Readings Taken
On The Work Plane.

. The window with square reveal admits the greatest illumination at points AI, BI and CI near the window, as in Figure 50 when compared with the other two types of windows. But this window gives less light at the other reference points than does the window with external reveal. While the window with square reveal gives from three to four times more light than does the window with internal reveal, at reference points AI, BI and CI, it gives approximately three times more light than in the latter case for the rest of the reference points.

. The window with external reveal admits more light into the areas remote from the window than do the other two types. For instance, at reference points AII, AIII, BII, BIII and CII, CIII, the window with external reveal admits about three and a half times more light than the window with internal reveal, and about 20 percent more light than that produced from the window with square reveal.

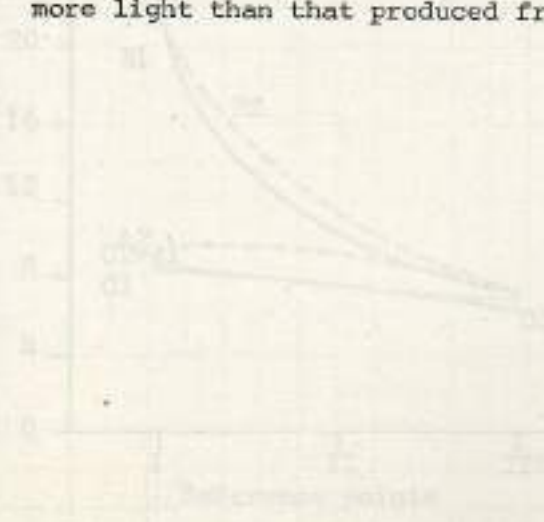

FIG. 50 Performance of window
2.40 x 1.30 meters
with reveals revealed
to the interior.

Room = 4.00 x 3.50 x 2.75 m.

Window = 2.40 x 1.30 m.

Sill = 0.90 m.

2.40m.

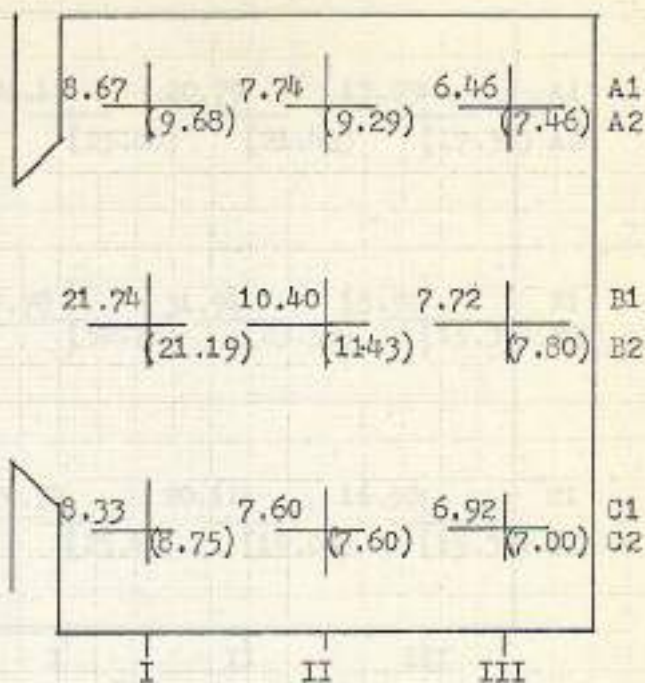

Reference points

Plan 1:50

Light source = Natural

Readings = On work plane

----- = Model on lawn

————— = Model on concrete

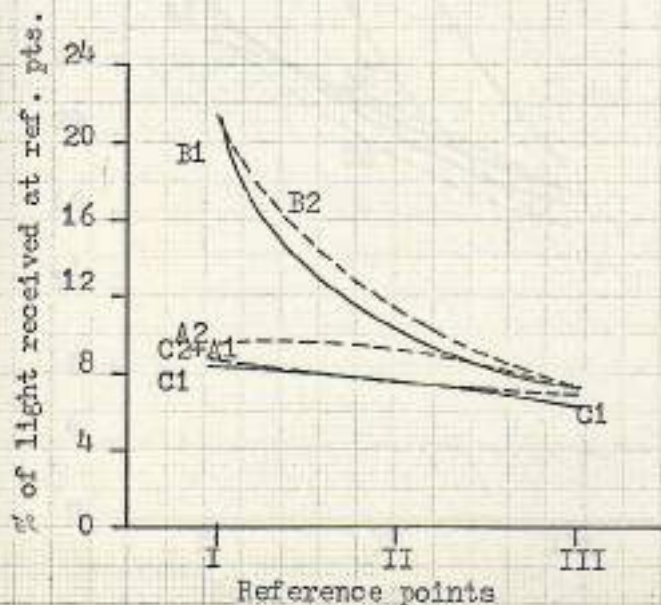
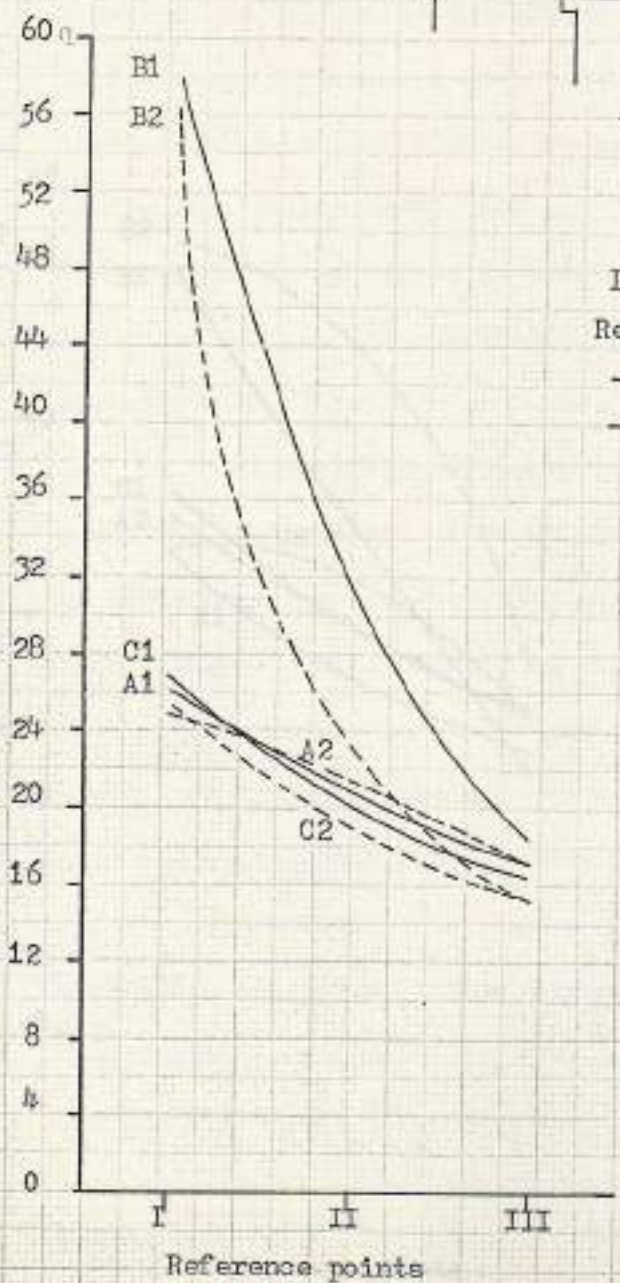
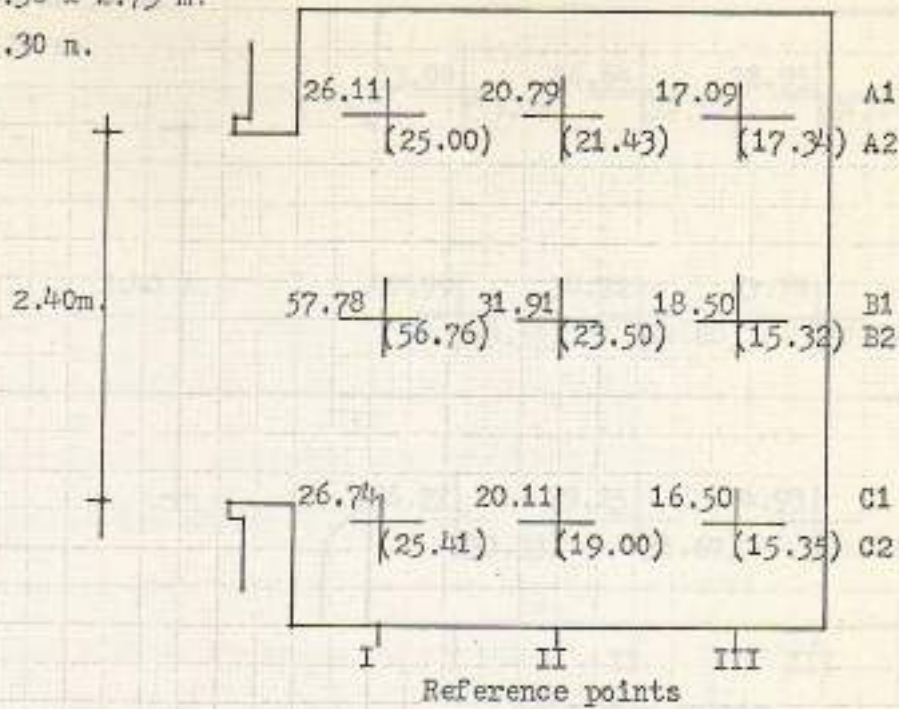

Fig. 49 Performance of window 2.40 x 1.30 Meters with reveals beveled to the interior

Room = 4.00 x 3.50 x 2.75 m.

Window = 2.40 x 1.30 m.

Sill = 0.90 m.



Light source = NATURAL
 Readings = ON work plane
 ----- = Model on lawn
 _____ = Model on concrete

Fig. 50 Performance of window 2.40 x 1.30 Meters with square reveals

Room = 4.00 x 3.50 x 1.30 m.

Window = 2.40 x 1.30 m.

Sill = 0.90 m.

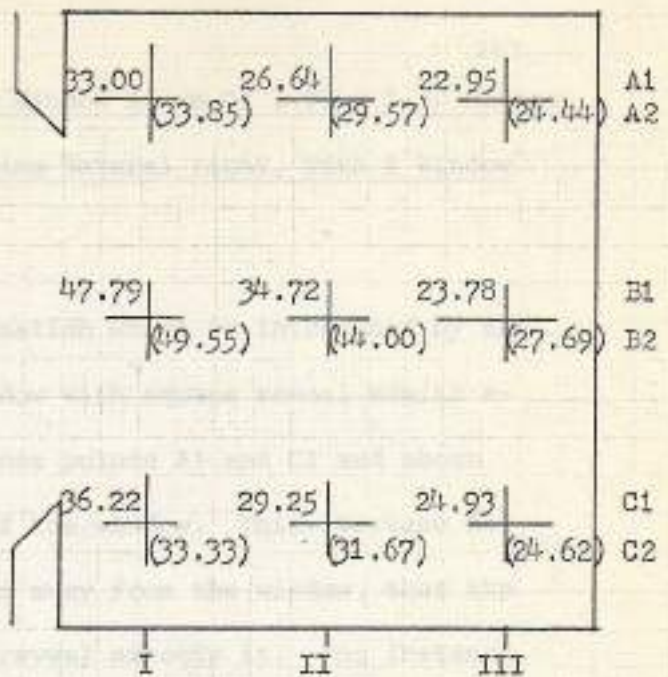
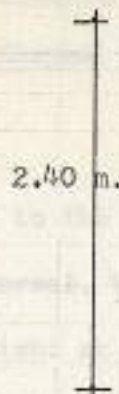

Reference points
Plan 1:50

- Light source = NATURAL
- Readings = On work plane
- = Model on lawn
- = Model on concrete

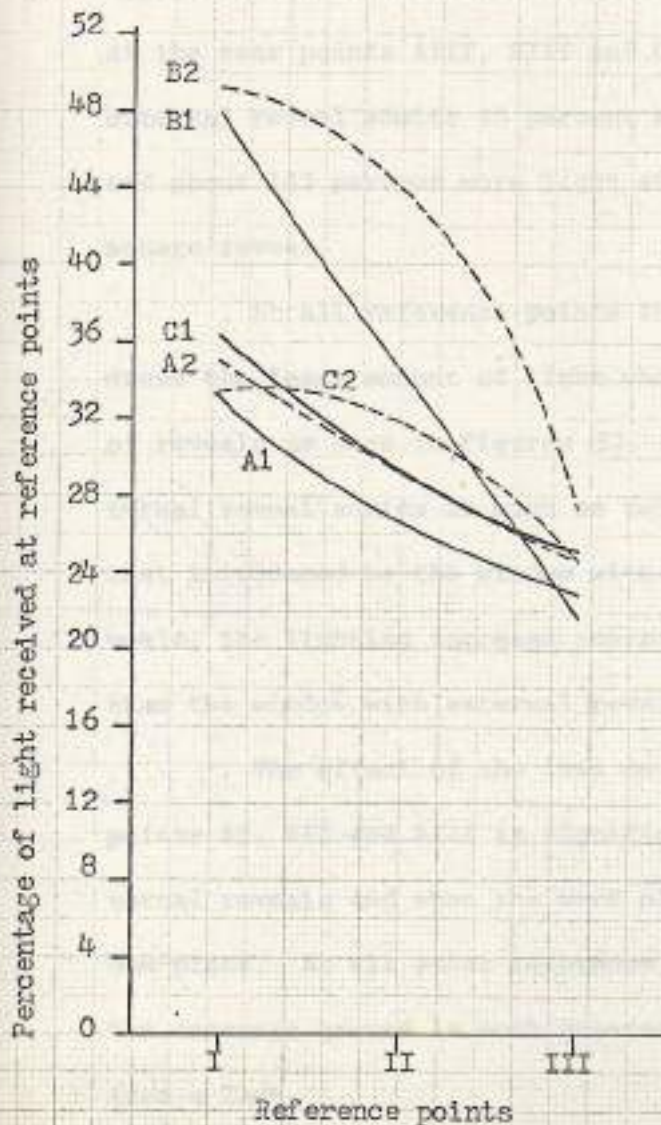

Fig. 51 Performance of window 2.40 x 1.30 Meters with reveals beveled to the exterior

Comparative Analysis Of Rooms Having Window Sizes Of 3.00 x 1.30 Meters
With Different Reveal Shapes, Employing Natural Light, With A Window
Centrally Located.

. When compared to the illumination which is introduced by the window with external reveal, the window with square reveal admits about 40 percent more light at reference points AI and CI and about 6 percent more light at the center of the window. This increase declines so rapidly as one goes farther away from the window, that the light from the window with external reveal exceeds it. For instance, at the rear points AIII, BIII and CIII in Figure 54, the window with external reveal admits 40 percent more light at points AIII and CIII and about 143 percent more light at BIII than does the window with square reveal.

. At all reference points the window with internal reveal produces the least amount of light when compared to the other two types of reveals as seen in Figures 52, 53, and 54. The window with external reveal admits as much as two to three times more light than that introduced by the window with internal reveal. With square reveals, the lighting increase averaged two and one-third times more than the window with external reveal.

. The effect of the lawn on the light received at reference points BI, BII and BIII is significant only when the window had external reveals and when the work plane was perpendicular to the window plane. At all other reference points the light reflected from the concrete ground is much greater than that which can be reflected from a lawn.

Room = 4.00 x 3.50 x 2.75 m.

Window = 3.00 x 1.30 m.

Sill = 0.90 m.

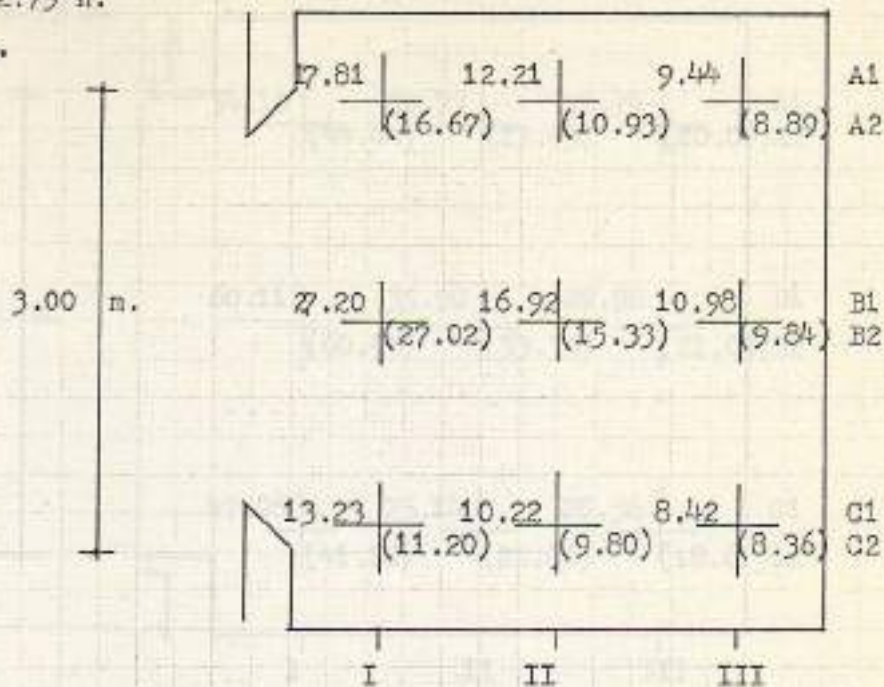

Reference points

Plan 1:50

Light source = NATURAL
 Readings = On work plane
 ----- = Model on lawn
 ————— = Model on concrete

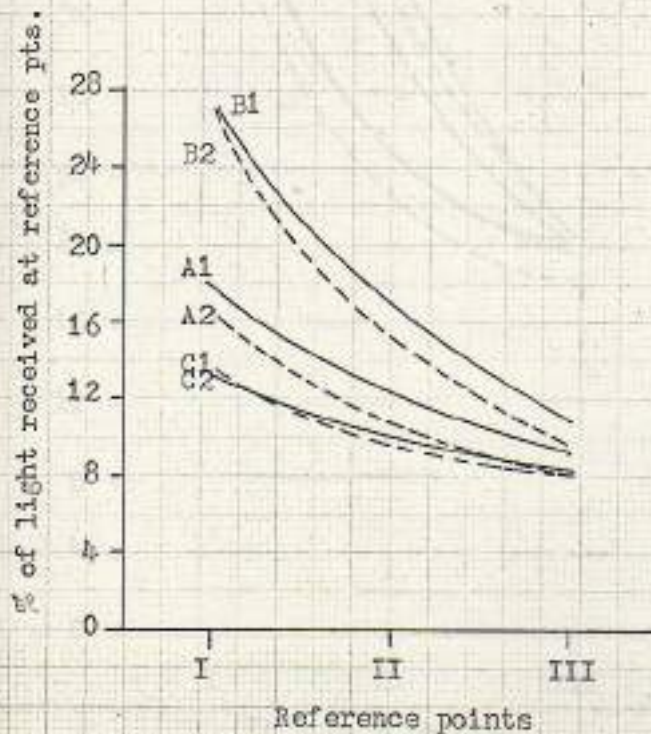

Fig. 52 Performance of window 3.00 x 1.30 Meters with reveals beveled to the interior

Room = 4.00 x 3.50 x 2.75 m.

Window = 3.00 x 1.30 m.

Sill = 0.90 m.

3.00 m.

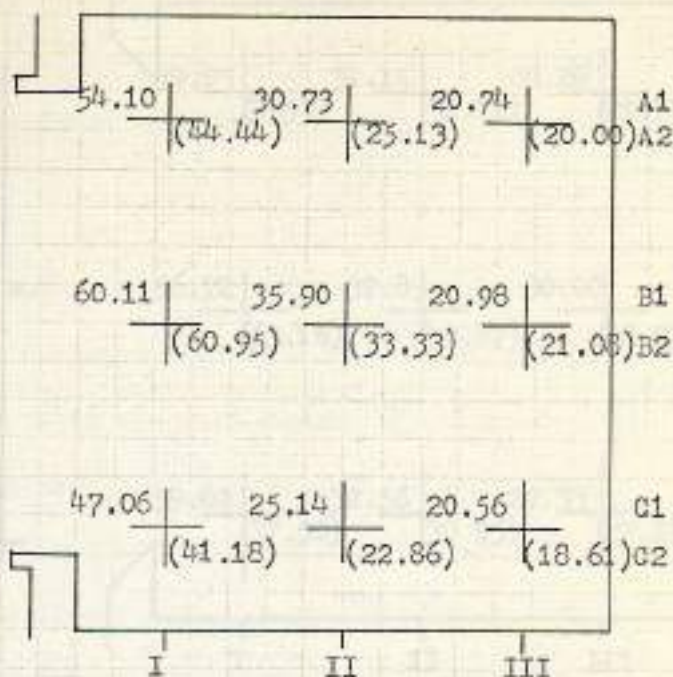

Plan 1:50

Reference points

Light source = NATURAL

Readings = On work plane

----- = Model on lawn

————— = Model on concrete

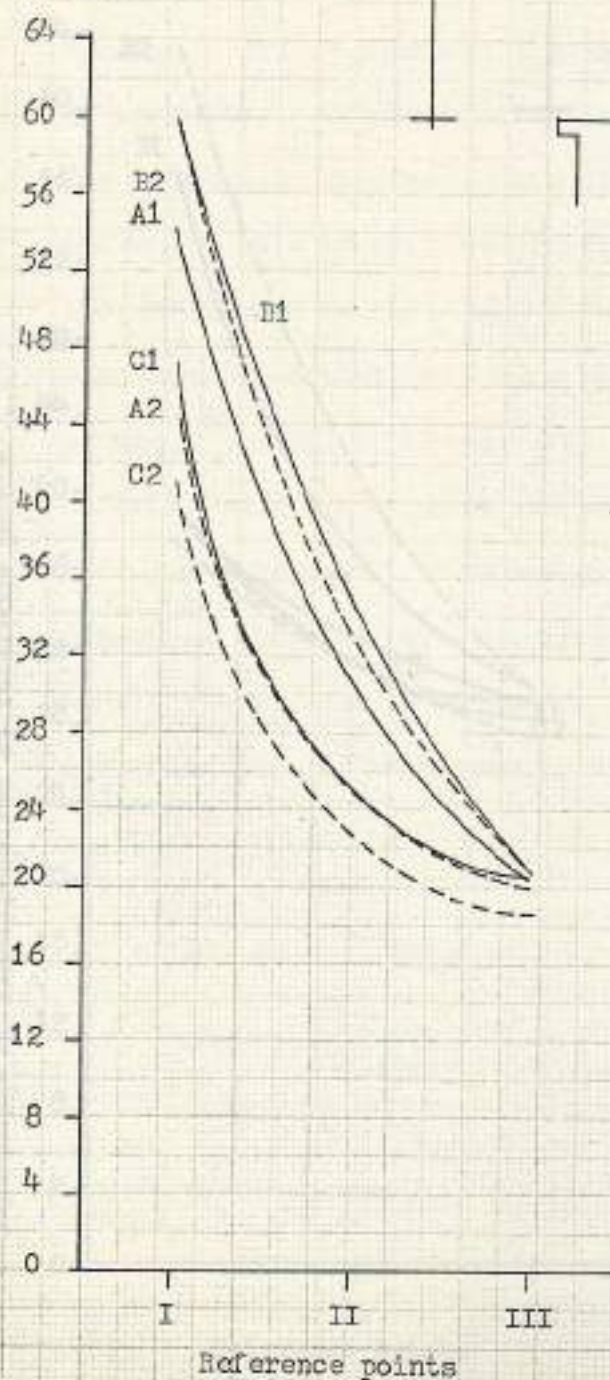

Fig. 53 Performance of window
3.00 x 1.30 with square
reveals

Room = 4.00 x 3.50 x 2.75 m.

Window = 3.00 x 1.30 m.

Sill = 0.90 m.

3.00 m.

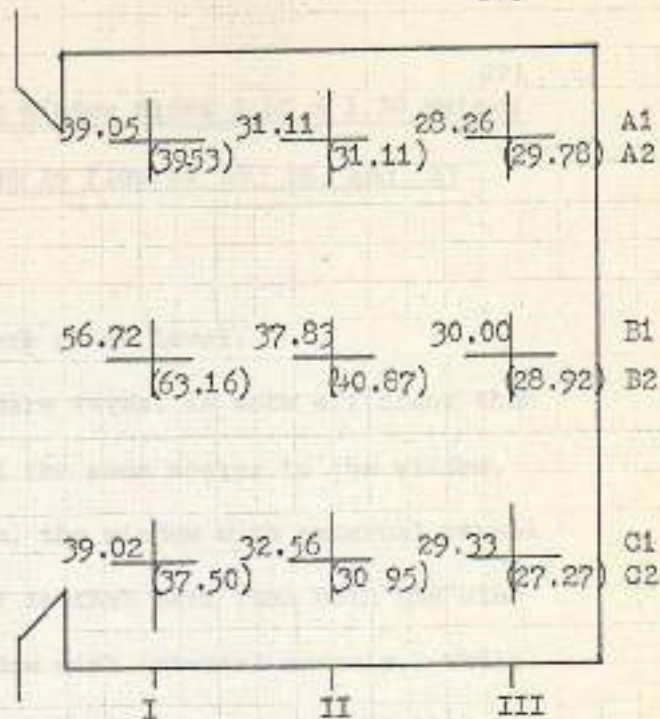

Reference points

Plan 1:50

- Light source = NATURAL
- Readings = On work plane
- = Model on lawn
- = Model on concrete

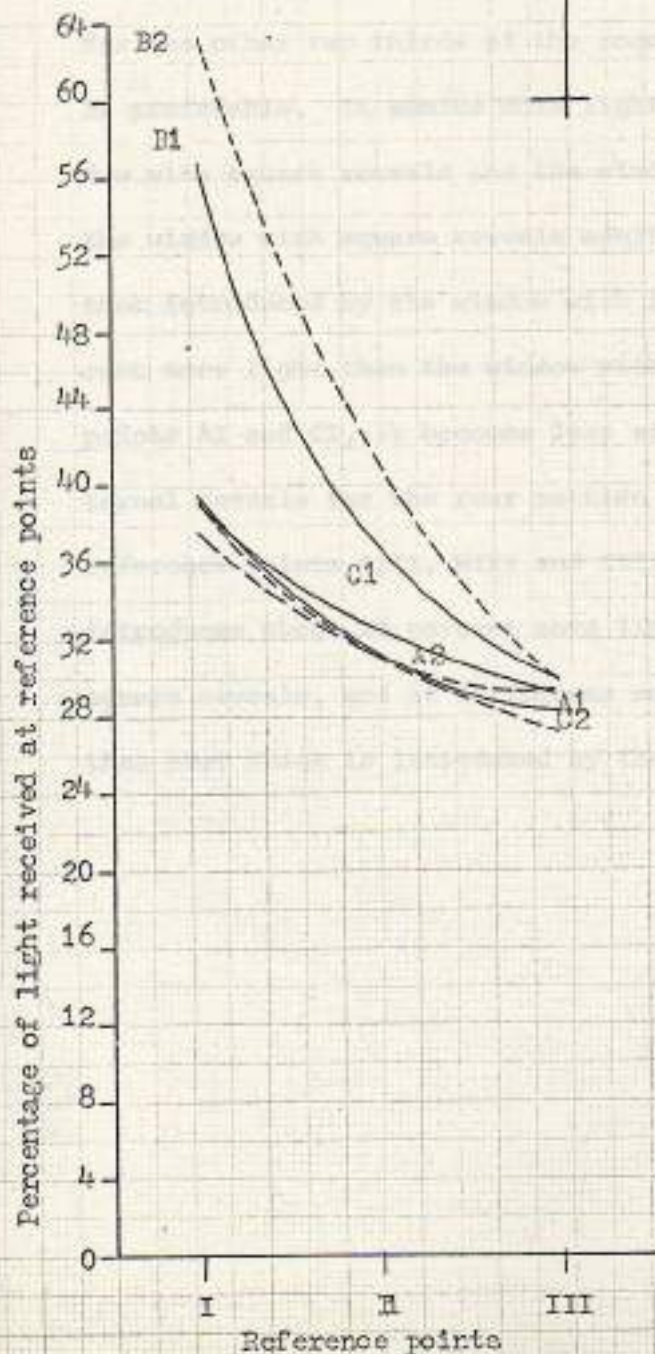

Fig. 54 Performance of window 3.00 x 1.30 Meters with reveals beveled to the exterior

Comparative Analysis Of Rooms Having Window Sizes 3.60 x 1.30 Meters
With Different Reveal Shapes As Shown In Figures 55, 56, and 57
Employing Natural Light.

Readings were taken at the work plane level.

While the window with a square reveal is more efficient than the other two types for the third of the room nearer to the window, for the other two thirds of the room, the window with external reveal is preferable. It admits more light in that part than both the window with square reveals and the window with internal reveals. While the window with square reveals admits three times more light than that introduced by the window with internal reveals and about 20 percent more light than the window with square reveals at reference points AI and CI, it becomes less efficient than the window with external reveals for the rear section of the room. For example, at reference points AIII, BIII and CIII, the window with external reveals introduces about 20 percent more light than does the window with square reveals, and it introduces more than two and a half times more than that which is introduced by the window with internal reveals.

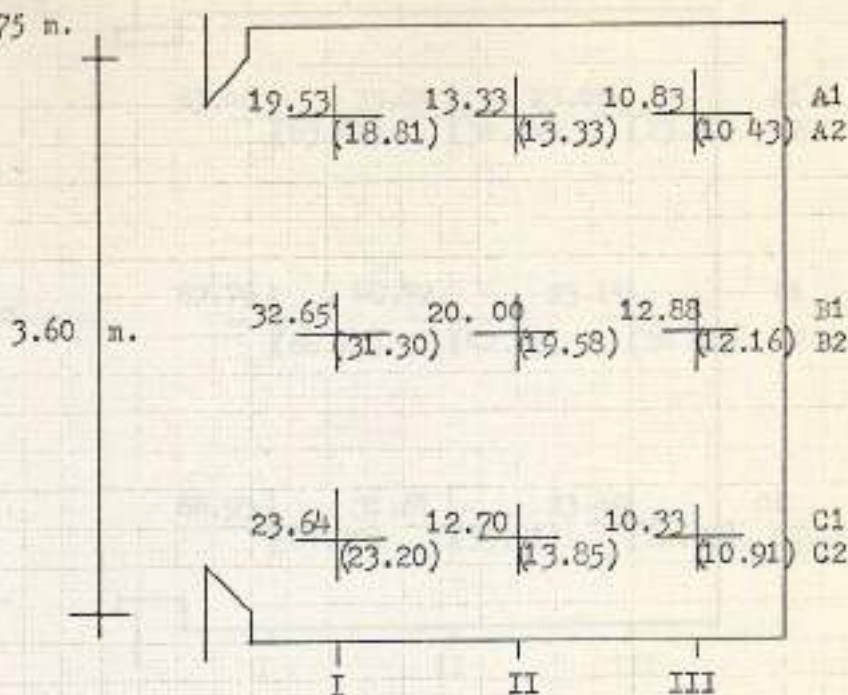

Fig. 55 Performance of window with reveals provided on the ceiling (window size 3.60 x 1.30 Meters)

Room = 4.00 x 3.50 x 2.75 m.

Window = 3.60 x 1.30 m.

Sill = 0.90 m.



Reference points

Plan 1:50

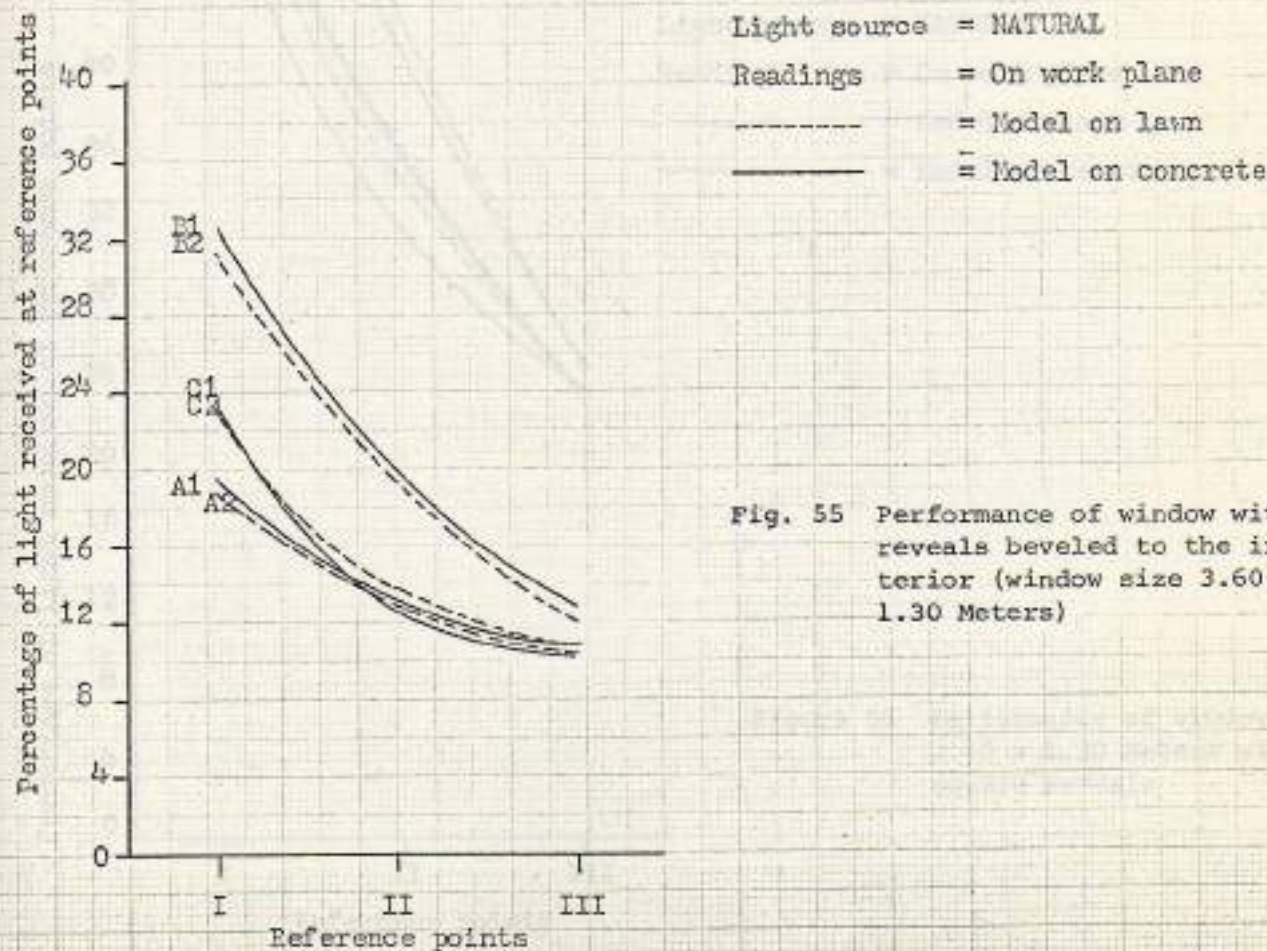
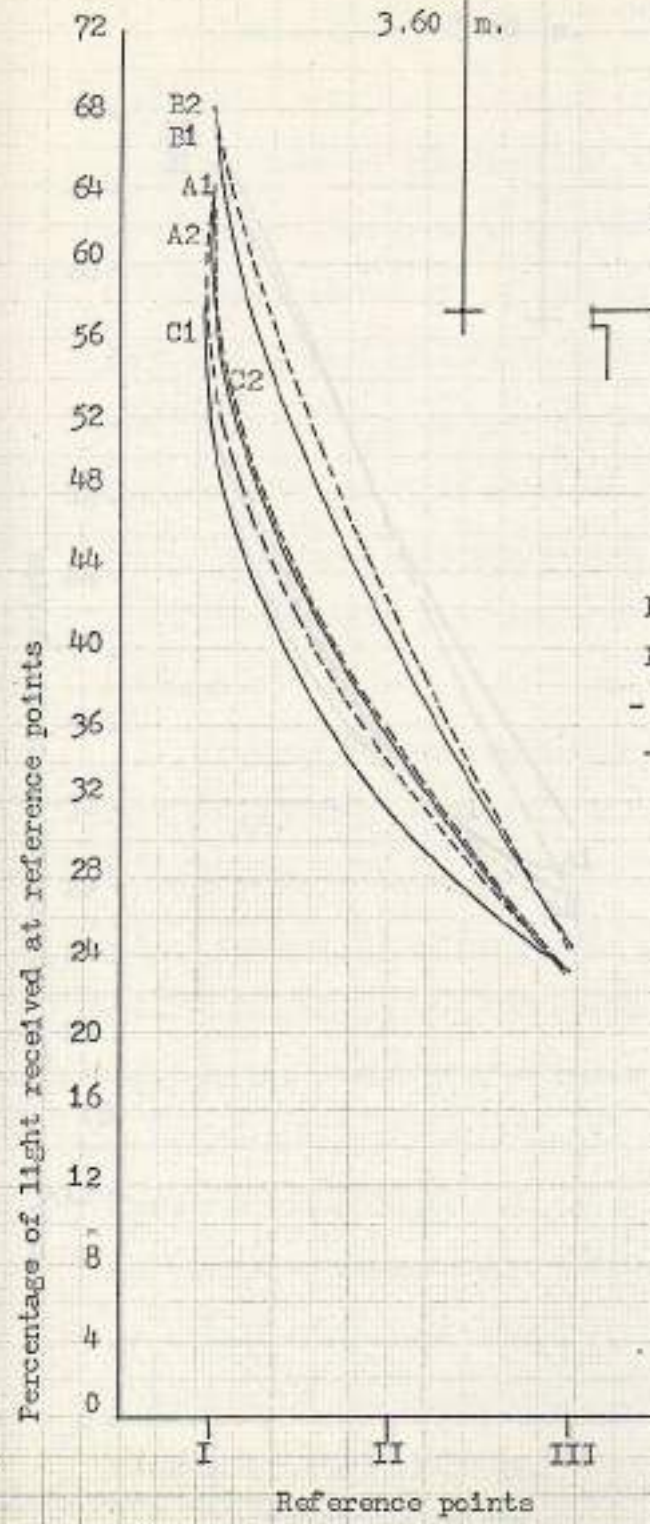
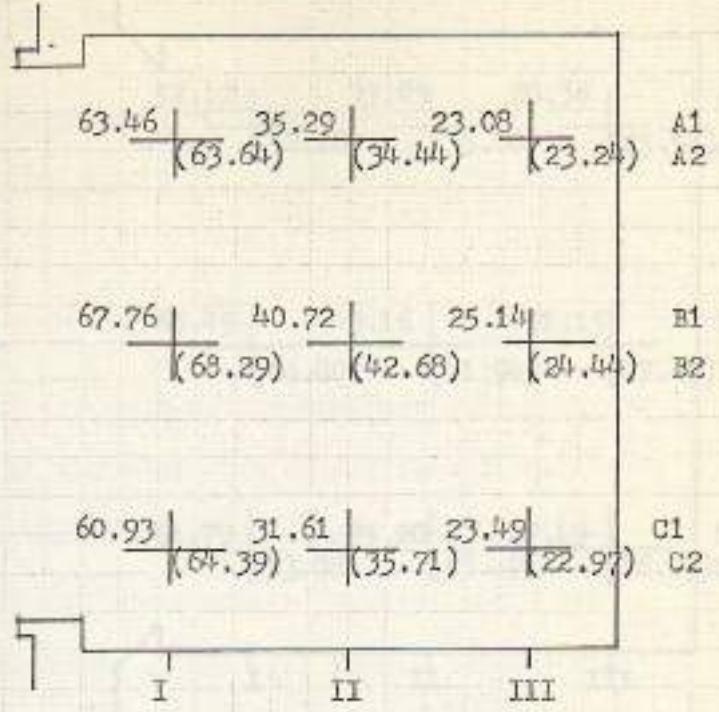

Fig. 55 Performance of window with reveals beveled to the interior (window size 3.60 x 1.30 Meters)

Room = 4.00 x 3.50 x 2.75 m.
 Window = 3.60 x 1.30 m.
 Sill = 0.90 m.



Light source = NATURAL
 Readings = On work plane
 - - - - - = Model on lawn
 ————— = Model on concrete

Figure 56 Performance of window
 3.60 x 1.30 Meters with
 square reveals

Room = 4.00 x 3.50 x 2.75 m.
 Window = 3.60 x 1.30 m.
 Sill = 0.90 m.

3.60 m.

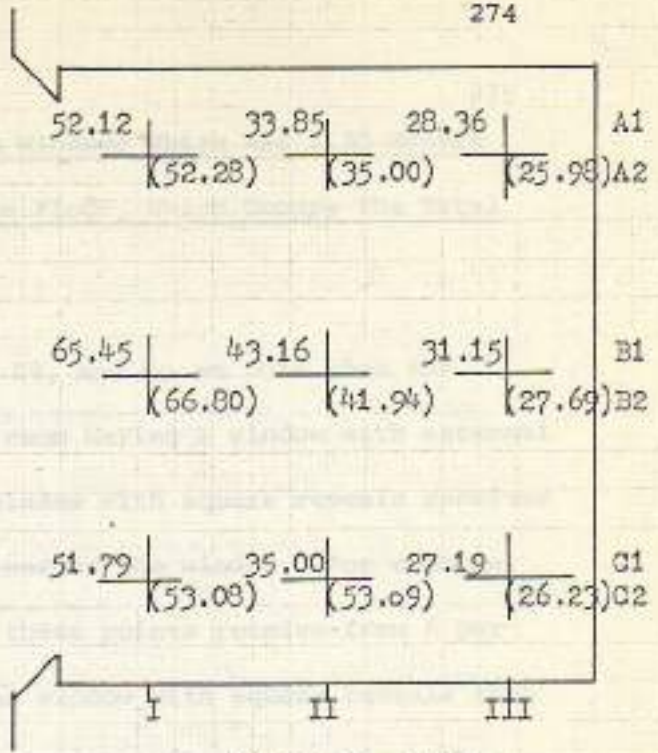

Reference points
 Plan 1:50

Light source = NATURAL
 Readings = On work plane
 ----- = Model on lawn
 _____ = Model on concrete

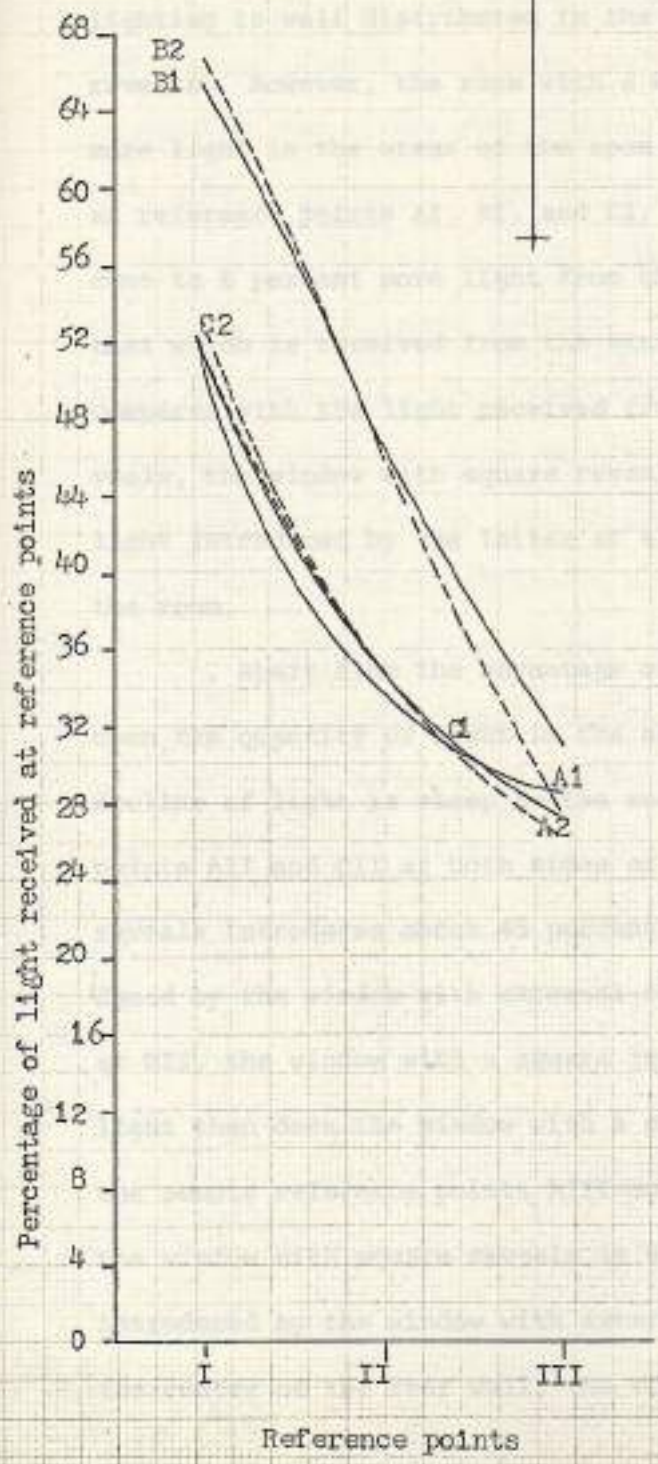

Fig. 57 Performance of window 3.60 x 1.30 Meters with reveals beveled to the exterior

Comparative Analysis Of Rooms Having Windows Which Are 1.30 Meters High With Sills 0.90 Meters Above The Floor, Which Occupy The Total Width Of The Room.

. When comparing Figures 58, 59, and 60 we note that the lighting is well distributed in the room having a window with external reveals. However, the room with a window with square reveals receives more light in the areas of the room nearer the window. For example, at reference points AI, BI, and CI, these points receive from 6 percent to 8 percent more light from the window with square reveals than that which is received from the window with external reveals. When compared with the light received from the window with internal reveals, the window with square reveals introduces more than twice the light introduced by the latter at almost all the reference points in the room.

. Apart from the advantage of the square reveals of the window upon the quantity of light in the area adjacent to the window, the decline of light is steep in the rest of the room. At reference points AII and CII at both sides of the window, the window with square reveals introduces about 45 percent less light than the light introduced by the window with external reveals. At the center of the room, at BII, the window with a square reveal introduces 20 percent less light than does the window with a external reveal. Furthermore, at the remote reference points AIII and CIII, the light introduced by the window with square reveals is 60 percent less than the light introduced by the window with external reveals. Also, at BIII near the center of the rear wall, the efficiency of the window with square

reveals is about 40 percent less than that of the window with external reveals.

. In the case of the window with internal reveals, the light is evenly spread over the entire space, but the level of illumination is still lower than that found in the other two rooms. The window with square reveals introduces twice as much as the light that is introduced by the window with internal reveals at almost all the reference points, as seen in Figures 58 and 60 . The window with external reveals introduces two to three times the light that is admitted by the window with internal reveals. For example, at reference points AIII, BIII and CIII, the window with external reveals introduces about three times the light that is admitted by the window with internal reveals. For the rest of the reference points, the window with external reveals introduces between two and three times the light that is introduced by the window with internal reveals.

. In this experiment, the effect of the lawn upon the quality of light in the interior of the room was found to be generally less than the effect of the concrete ground on the latter.

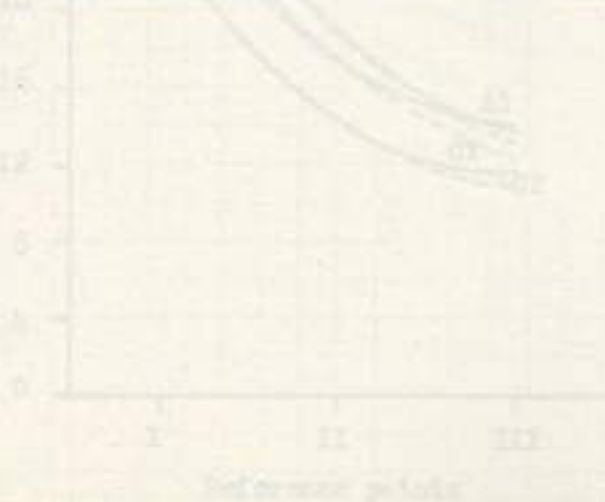
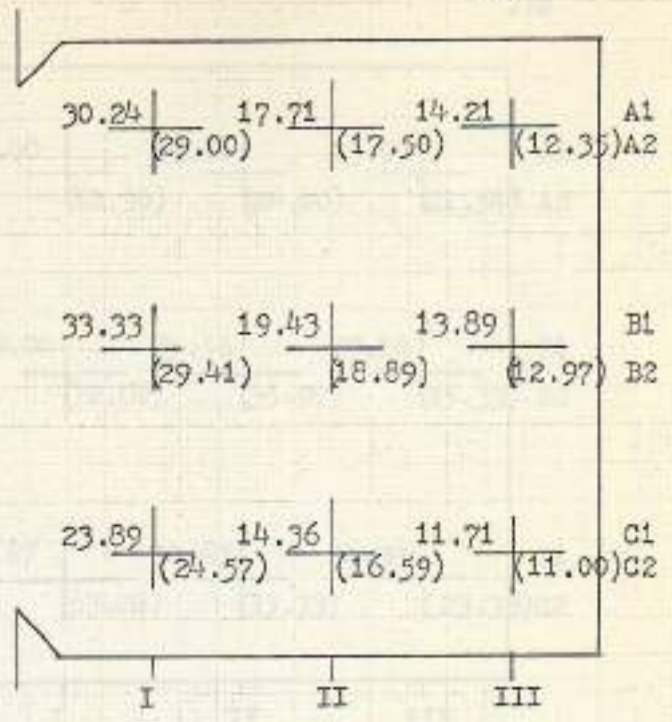

Fig. 58 Performance of window 1.20 x 1.20 meters with reveals revealed to the interior.

Room = 4.00 x 3.50 x 2.75 m.
 Window = 4.00 x 1.30 m.
 Sill = 0.90 m.

4.00m.



Reference points

Plan 1:50

Light source = NATURAL
 Readings = On work plane
 ----- = Model on lam
 _____ = Model on concrete

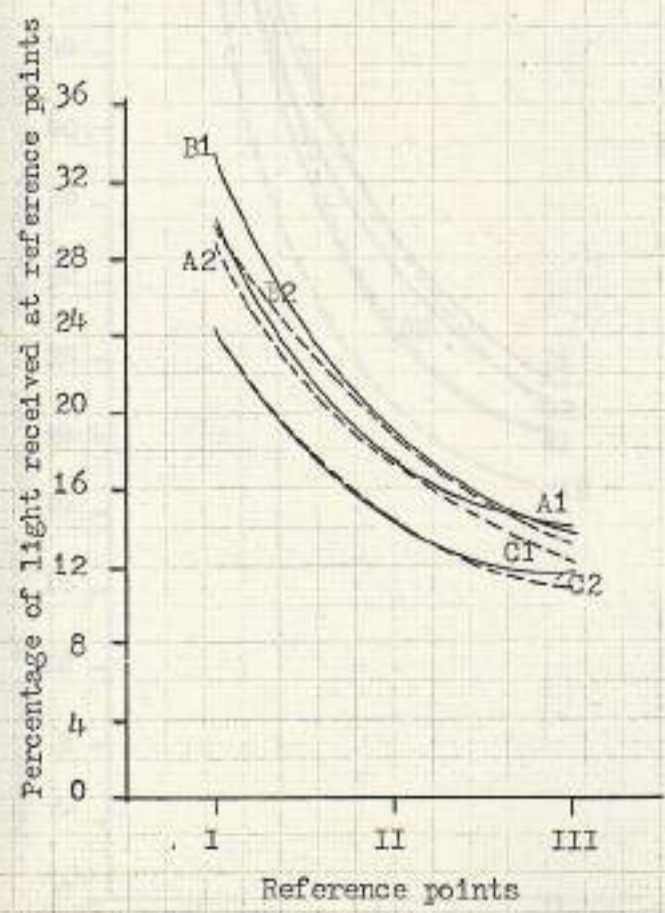
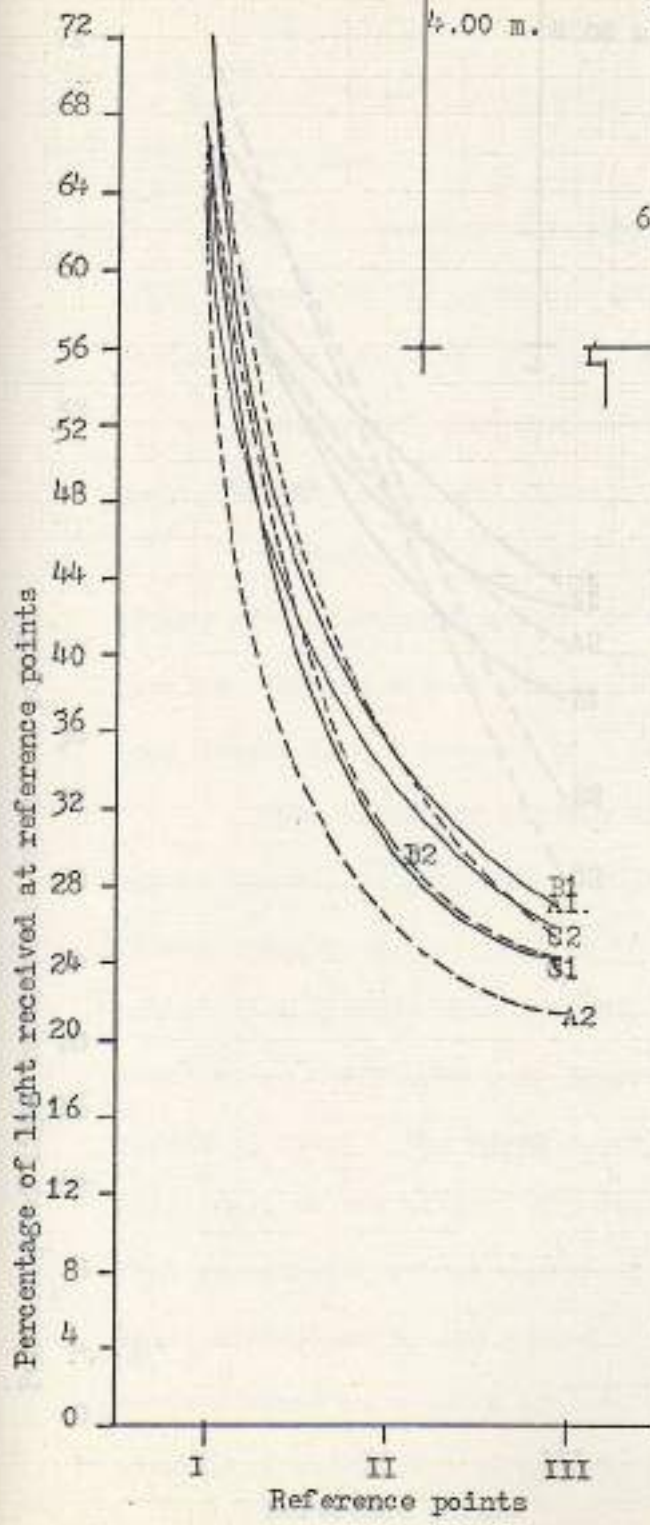
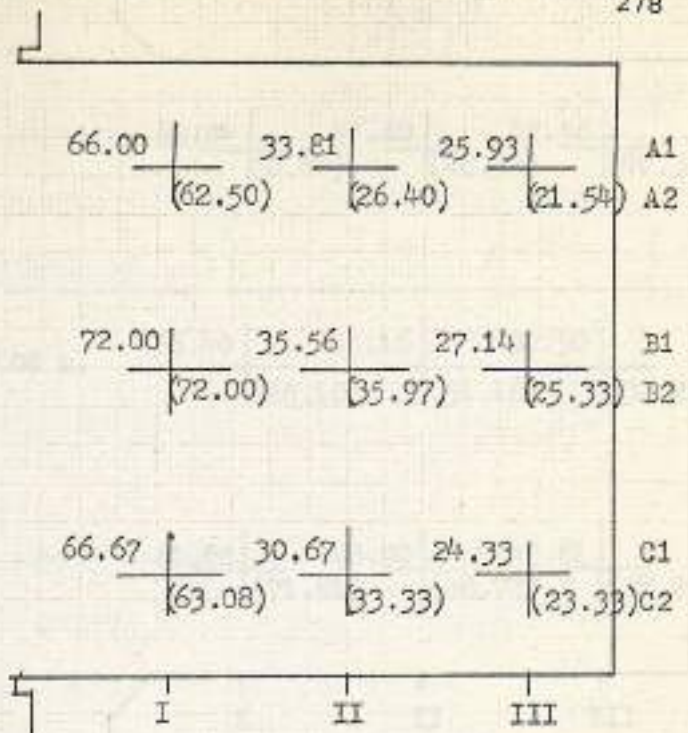

Fig. 58 Performance of window 4.00 x 1.30 Meters with reveals beveled to the interior

Room = 4.00x3.50x2.75 m.
 Window = 4.00 x 1.30
 Sill = 0.90 m.



Plan 1:50

Light source = NATURAL
 Readings = On work plane
 ----- = Model on lawn
 _____ = Model on concrete

Fig. 59 Performance of window 4.00 x 1.30 Meters with square reveals

Room = 4.00 x 3.50 x 2.75 m.

Window = 4.00 x 1.30 m.

Sill = 0.90m.

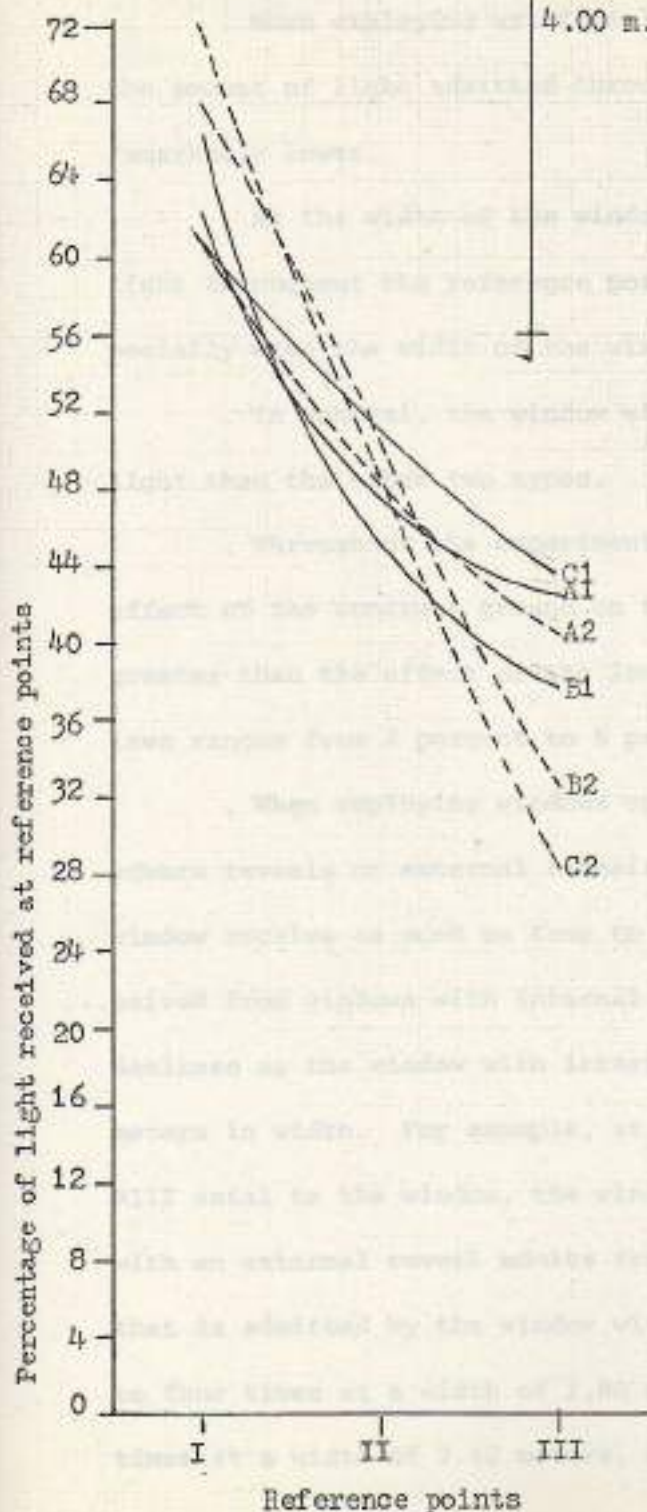

62.24 | 47.80 | 42.56 | A1
 |-----|-----|-----| A2
 60.87 | (48.33) | (40.31)

66.40 | 45.16 | 37.50 | B1
 |-----|-----|-----| B2
 (68.10) | (51.16) | (32.22)

61.02 | 48.00 | 43.61 | C1
 |-----|-----|-----| C2
 (71.81) | (48.72) | (28.29)

4.00 m.

I II III

Reference points

Plan 1:50

Light source = NATURAL

Readings = On work plane

----- = Model on lawn

————— = Model on concrete

Fig. 60 Performance of window 4.00 x 1.30 Meters with reveals beveled to the exterior

Comparative Analysis Of Rooms Having Windows With Different Reveal Shapes, Employing Artificial Lighting With Reference To Work Planes, As Indicated In Figures 61 through 78.

. When employing artificial light rather than natural light, the amount of light admitted through the window in all three cases is remarkably lower.

. As the width of the window increases, the distribution of light throughout the reference points becomes more homogeneous, especially when the width of the window exceeds 2.40 meters.

. In general, the window with an external reveal admits more light than the other two types.

. Throughout the experiments with artificial lighting, the effect of the concrete ground on the quantity of illumination is greater than the effect of the lawn. The loss of light due to the lawn ranges from 2 percent to 5 percent.

. When employing windows up to 1.80 meters in width with square reveals or external reveals, the reference points near the window receive as much as four to five times the light that is received from windows with internal reveals. However, this proportion declines as the window with internal reveals increases beyond 1.80 meters in width. For example, at the reference points BI, BII, and BIII axial to the window, the window whose width is 1.70 meters with an external reveal admits from four to five times the light that is admitted by the window with internal reveals, but from three to four times at a width of 1.80 meters, from two and a half to three times at a width of 2.40 meters, and from two to less than three

Room = 3.30 x 3.30 x 2.70 m.
 Windows = 1.20 x 1.20 m.

times at a width of 3.00 meters. This also happens to the reference points flanking the windows. However, this amount becomes two times less when the window with internal reveals occupies the whole width of the room.

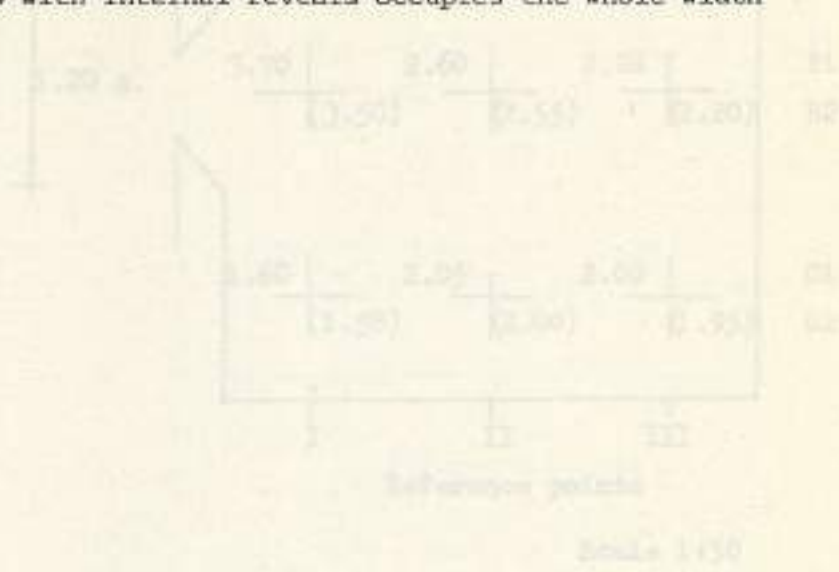

- Light source = ARTIFICIAL
- Seatings = On work plane
- _____ = Model on lamp
- _____ = Model on concrete

Fig. 21 Performance of window 1.20 x 1.20 meters with reveals revealed to the interior when employing artificial light.



Room = 4.00 x 3.50 x 2.75 m.

Window = 1.20 x 1.30 m.

Sill = 0.90 m.

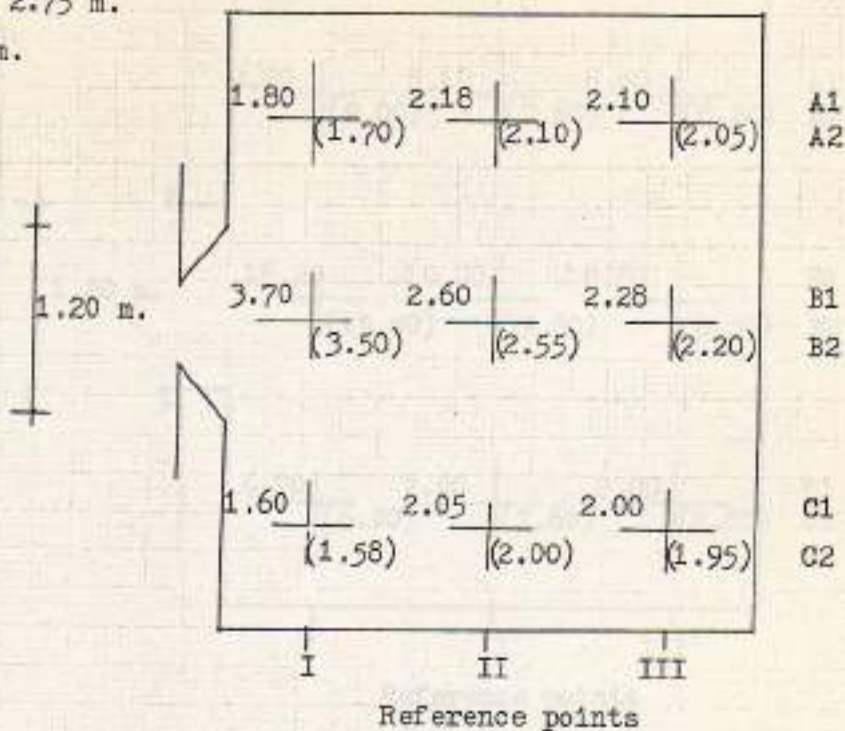

Scale 1:50

Light source = ARTIFICIAL
 Readings = On work plane
 ----- = Model on lawn
 _____ = Model on concrete

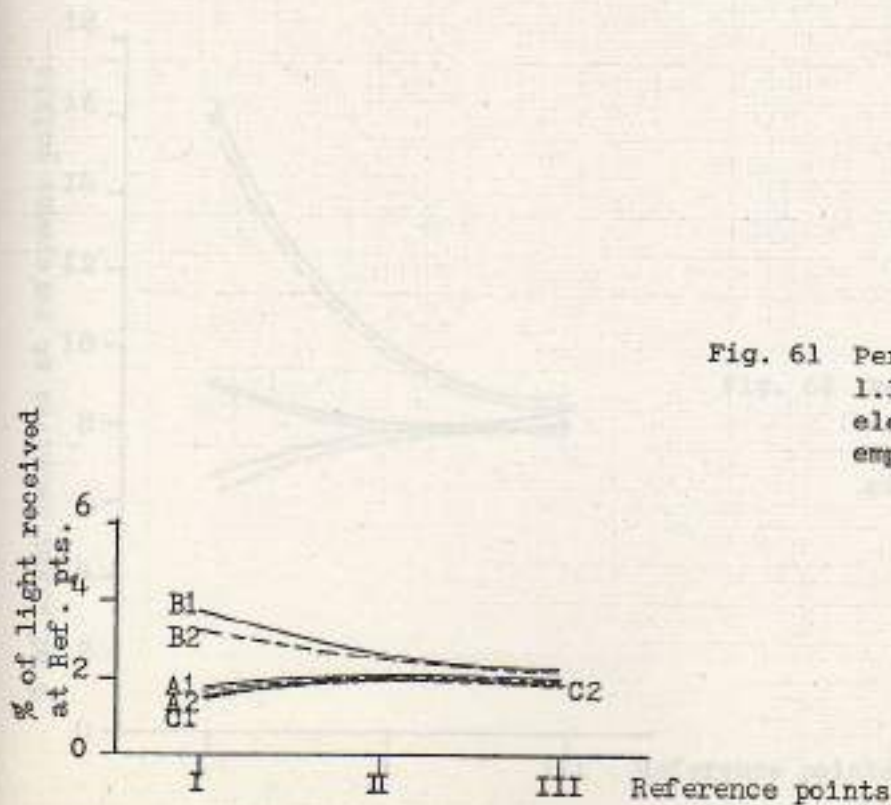
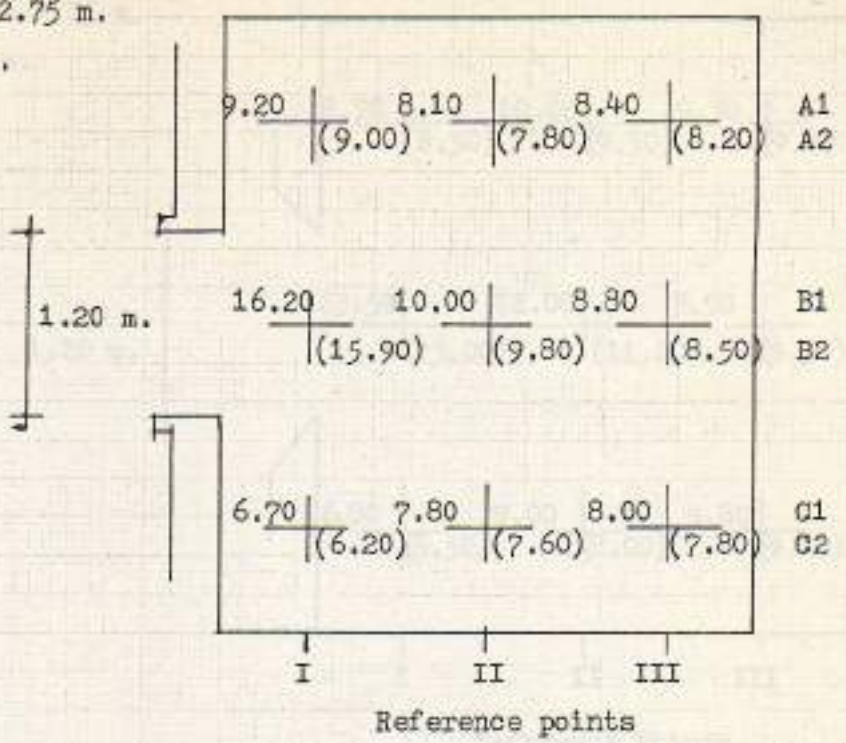

Fig. 61 Performance of window 1.20 x 1.30 Meters with reveals beveled to the interior when employing artificial light

Room = 4.00 x 3.50 x 2.75 m.
 Window = 1.20 x 1.30 m.
 Sill = 0.90 m.



Plan 1:50

Light source = ARTIFICIAL
 Readings = On work plane
 ----- = Model on lawn
 ————— = Model on concrete

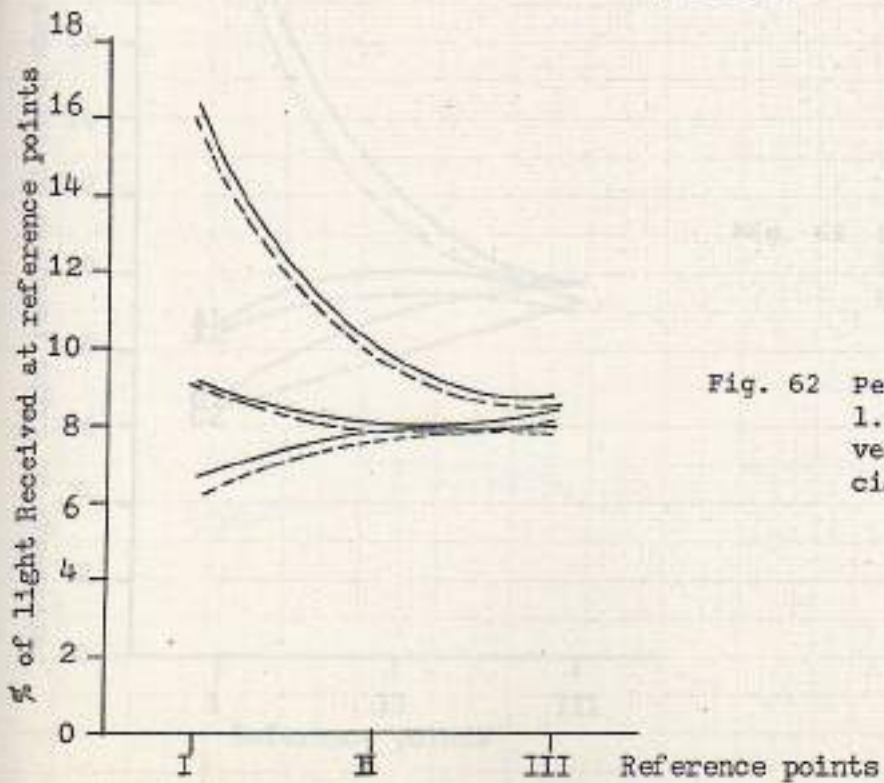

Fig. 62 Performance of window 1.20 x 1.30 Meters with square reveals when employing artificial light

Room = 4.00 x 3.50 x 2.75 m.

Window = 1.20 x 1.30 m.

Sill = 0.90 m.

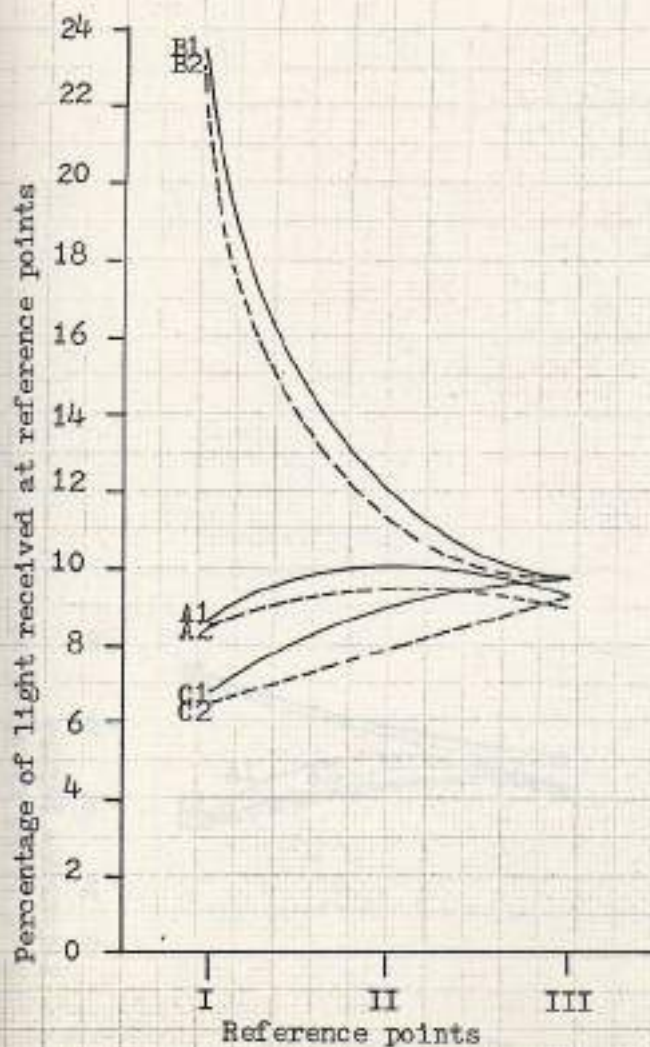
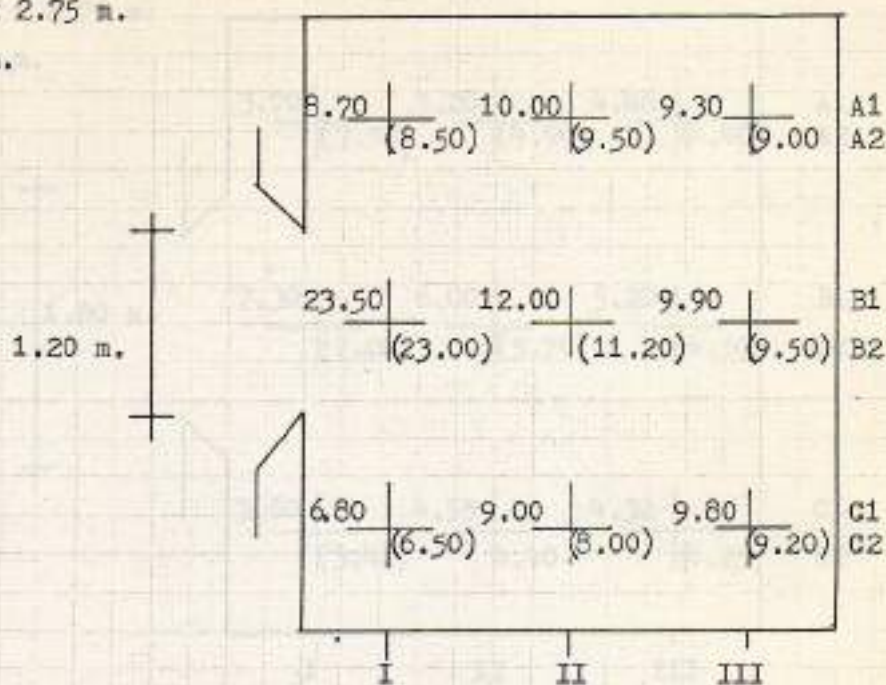
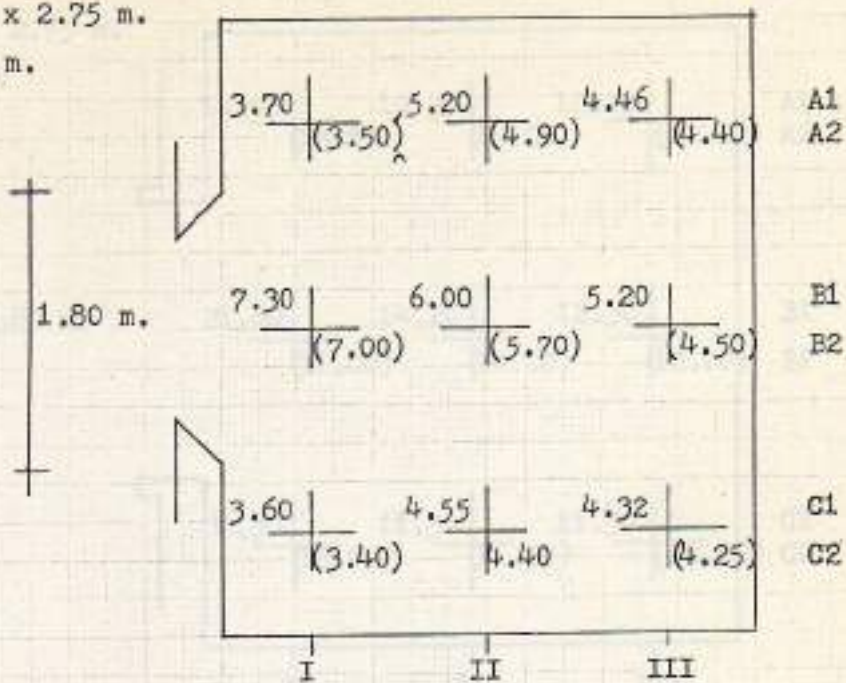

Fig. 63 Performance of window 1.20 x 1.30 Meters with reveals beveled to the exterior

Room = 4.00 x 3.50 x 2.75 m.
 Window = 1.80 x 1.30 m.
 Sill = 0.90 m.



Reference points

Plan 1:50

- Light source = ARTIFICIAL
- Readings = On work plane
- = Model on lawn
- = Model on concrete

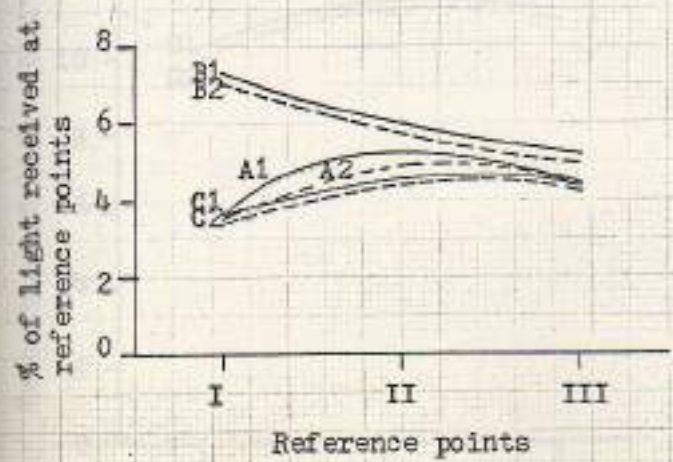
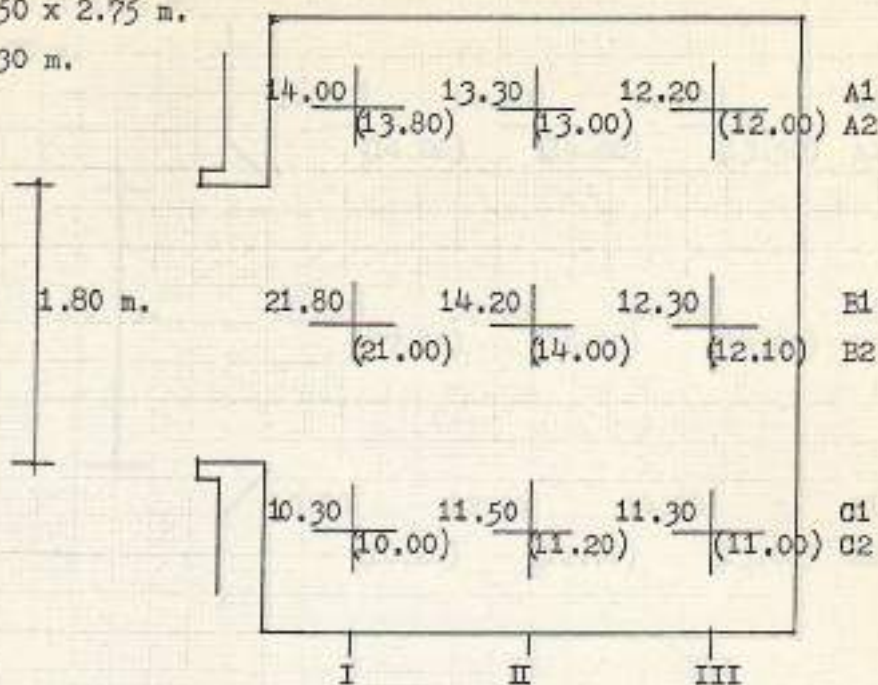

Fig. 64 Performance of window 1.80 x 1.30 Meters having reveals beveled to the interior

Room = 4.00 x 3.50 x 2.75 m.

Window = 1.80 x 1.30 m.

Sill = 0.90 m.



Reference points

Plan 1:50

Light source = ARTIFICIAL
 Readings = On work plane
 ----- = Model on lawn
 ————— = Model on concrete

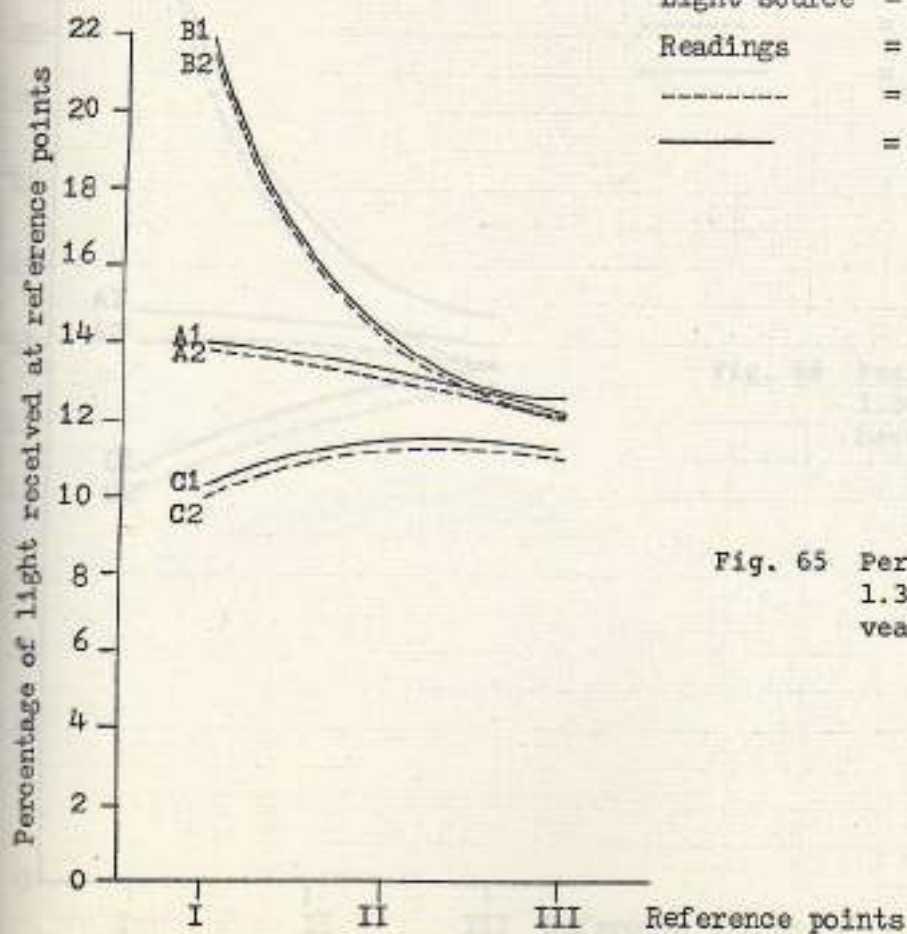
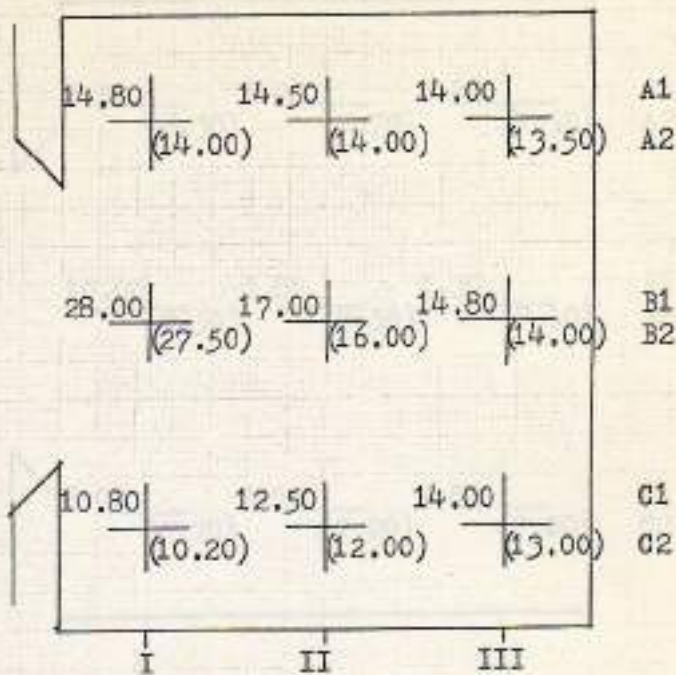
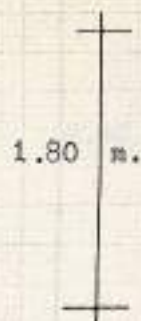

Fig. 65 Performance of window 1.80 x 1.30 Meters with square reveals

Room = 4.00 x 3.50 x 2.75 m.
 Window = 1.80 x 1.30 m.
 Sill = 0.90 m.



Reference points
 Plan 1:50

Light source = ARTIFICIAL
 Readings = On work plane
 - - - - - = Model on lawn
 ————— = Model on concrete

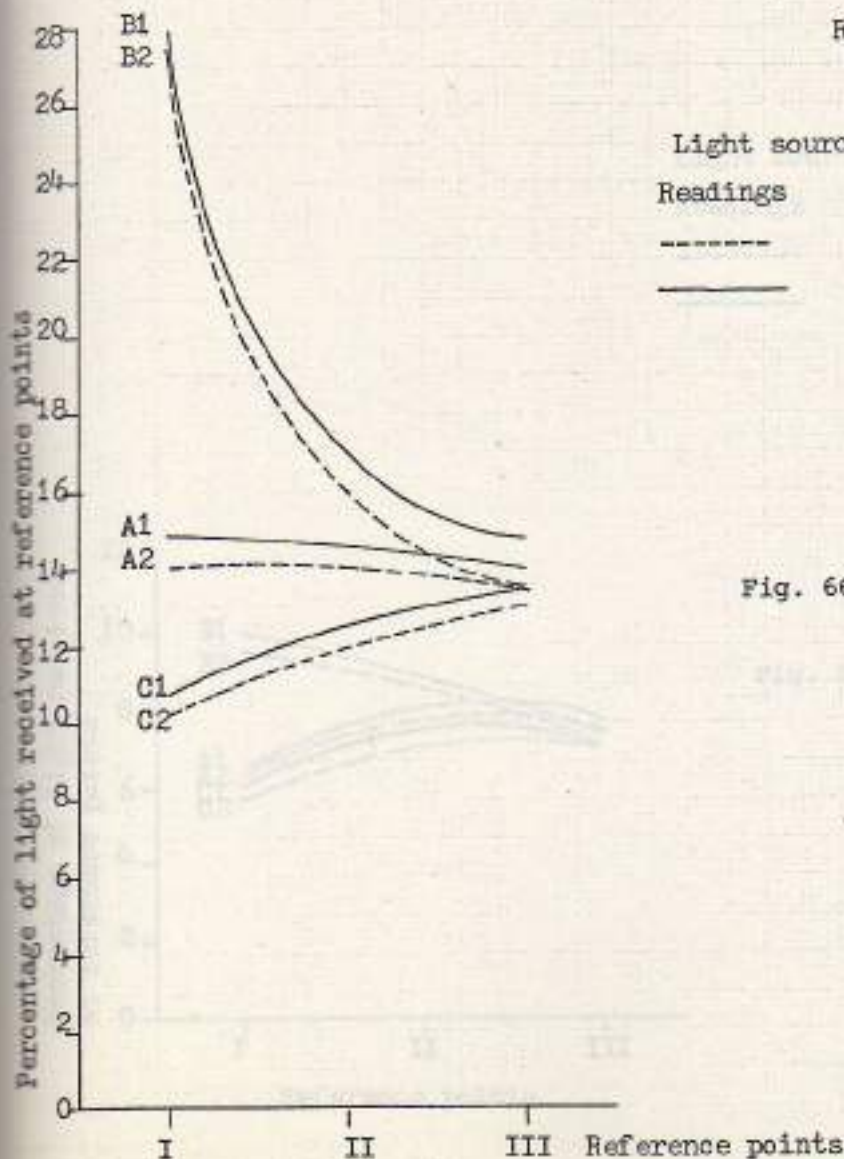
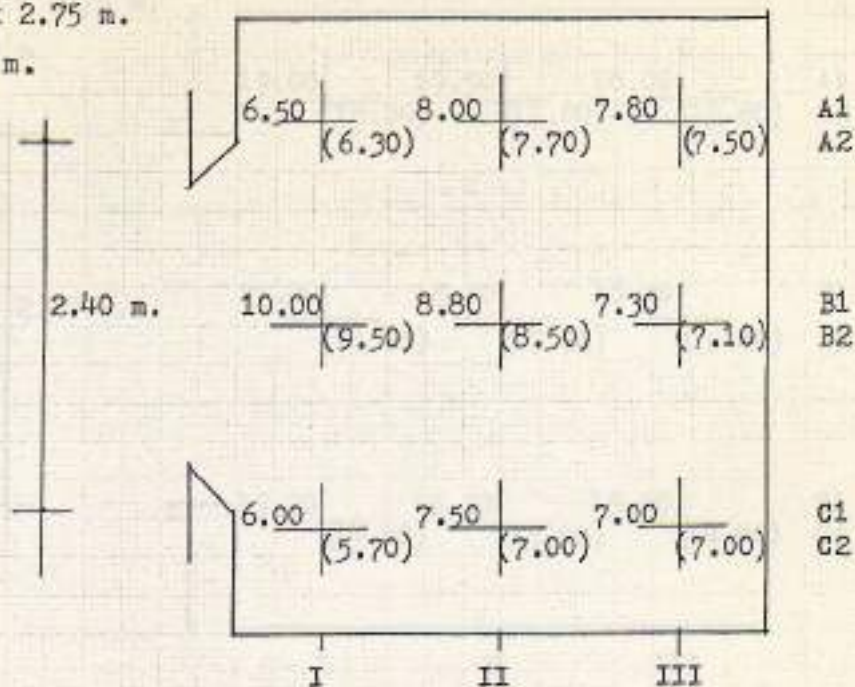

Fig. 66 Performance of window 1.80 x 1.30 Meters having reveals beveled to the exterior

Room = 4.00 x 3.50 x 2.75 m.

Window = 2.40 x 1.30 m.

Sill = 0.90 m.



Reference points

Plan 1:50

Light source = ARTIFICIAL

Readings = ON work Plane

----- = Model on lawn

————— = Model on concrete

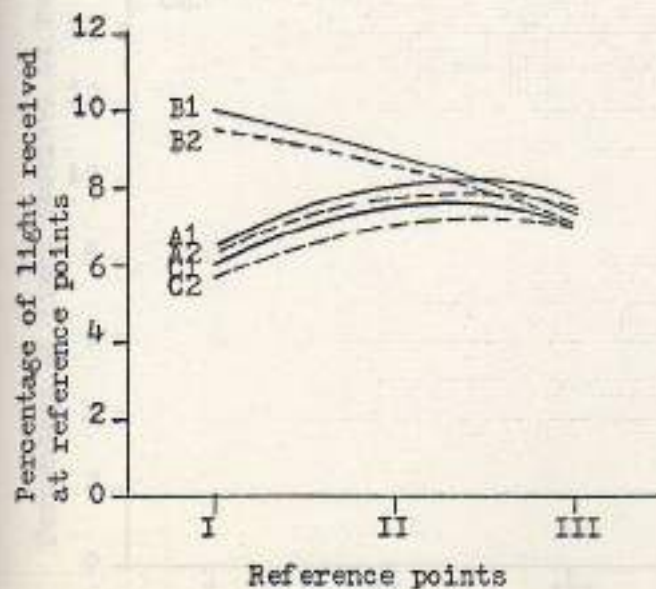
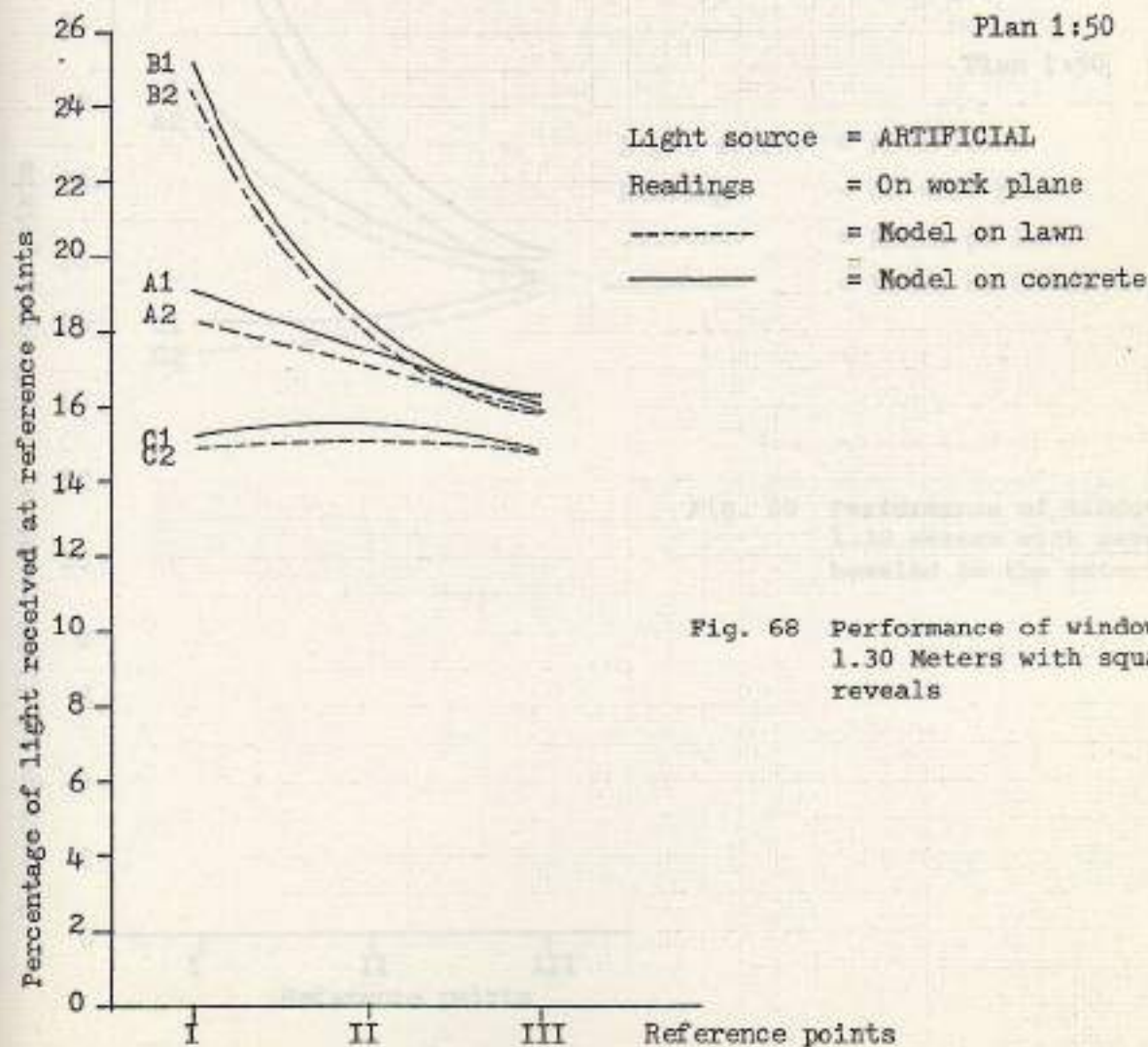
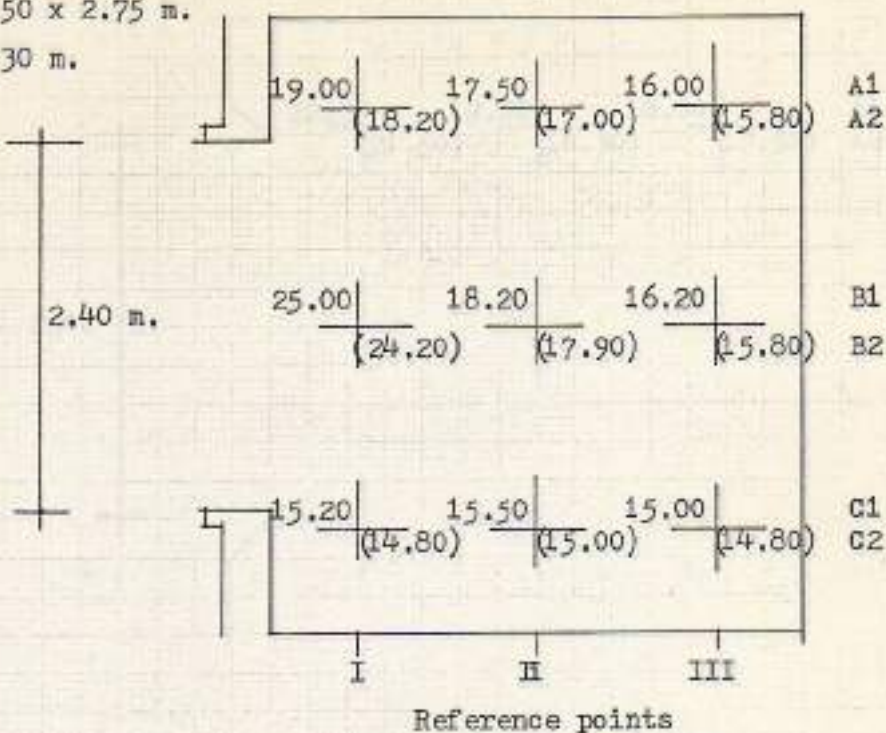

Fig. 67 Performance of window 2.40 x 1.30 Meters having reveals beveled to the interior

Room = 4.00 x 3.50 x 2.75 m.

Window = 2.40 x 1.30 m.

Sill = 0.90 m.



Room = 4.00 x 3.50 x 2.75 m.

Window = 2.40 x 1.30 m.

Sill = 0.90 m.

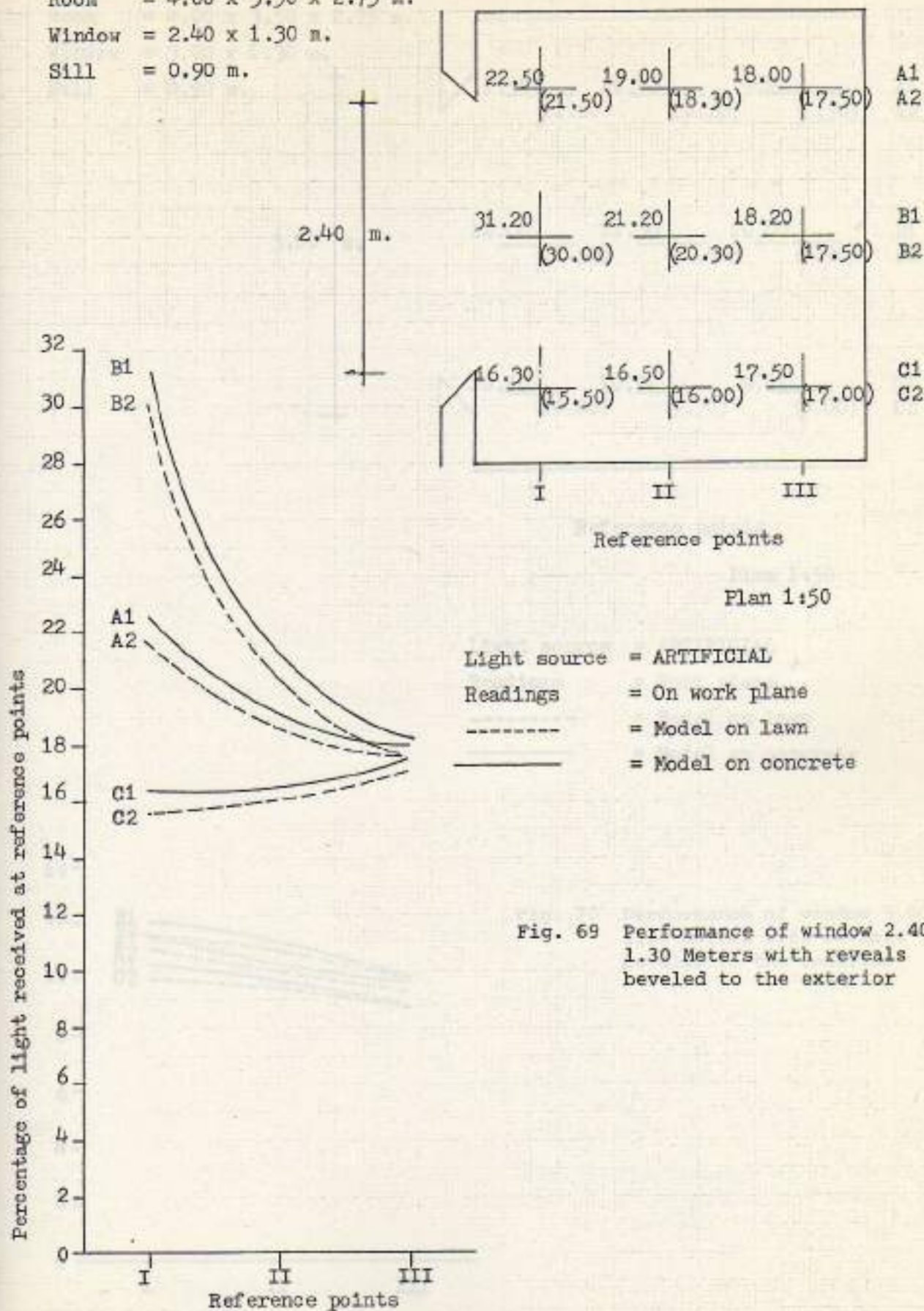
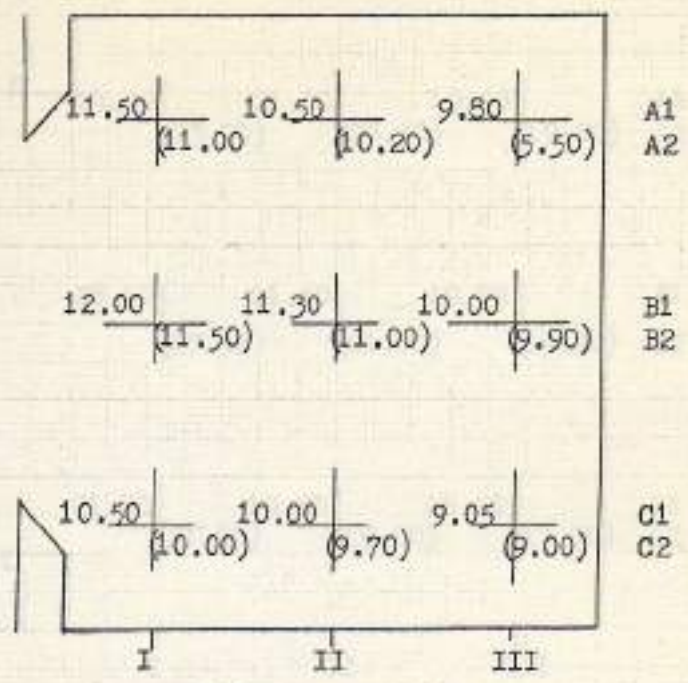

Fig. 69 Performance of window 2.40 x 1.30 Meters with reveals beveled to the exterior

Room = 4.00 x 3.50 x 2.75 m.
 Window = 3.00 x 1.30 m.
 Sill = 0.90 m.



Reference points

Plan 1:50

- Light source = ARTIFICIAL
- Readings = Work plane
- = Model on lawn
- = Model on concrete

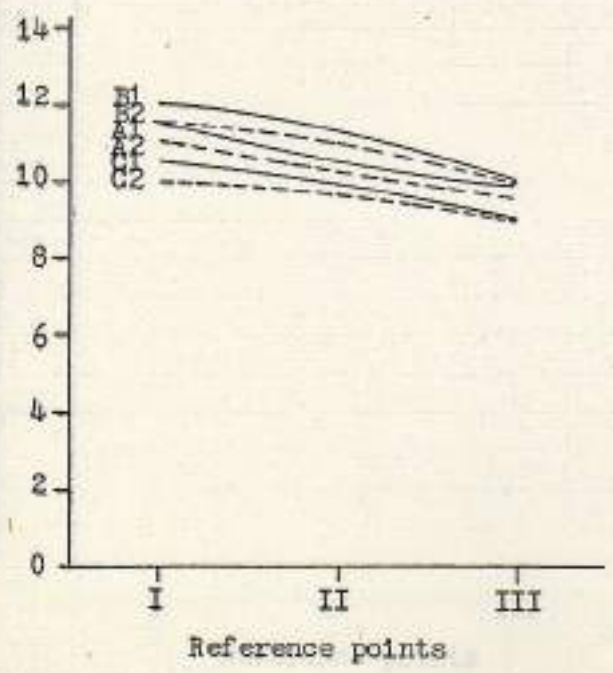

Fig. 70 Performance of window 3.00 x 1.30 Meters with reveals beveled to the interior

Fig. 71 Performance of window 3.00 x 1.30 Meters with square reveals

Room = 4.00 x 3.50 x 2.75 m.

Window = 3.00 x 1.30 m.

Sill = 0.90 m.

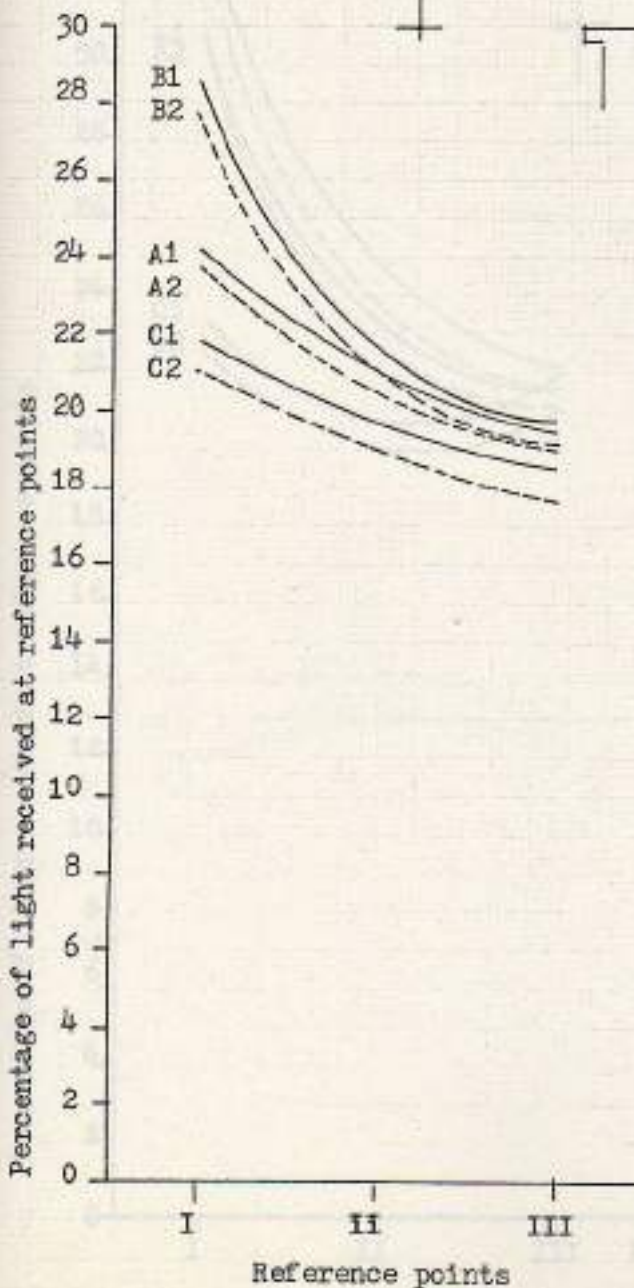
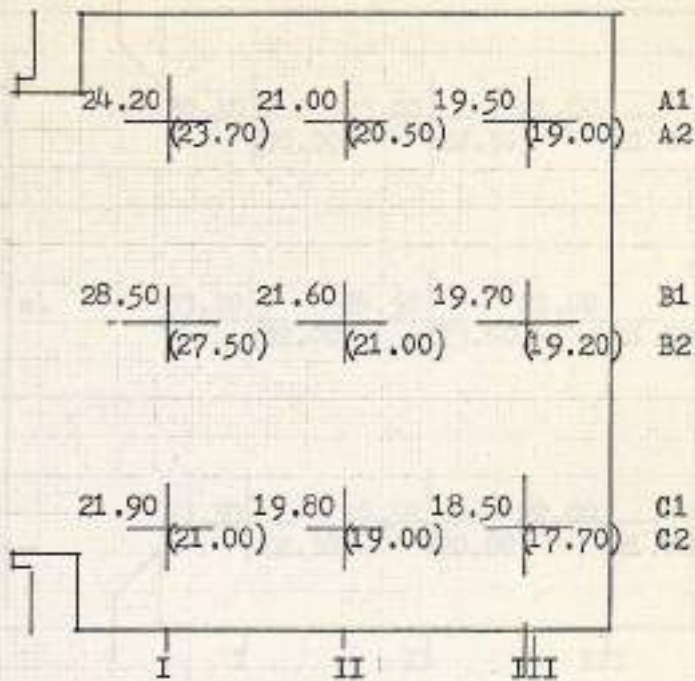

Light source = ARTIFICIAL
 Readings = On work plane
 ----- = Model on lawn
 _____ = Model on concrete

Fig. 71 Performance of window 3.00 x 1.30 Meters with square reveals

Room = 4.00 x 3.50 x 2.75 m.

Window = 3.00 x 1.30 m.

Sill = 0.90 m.

3.00 m.

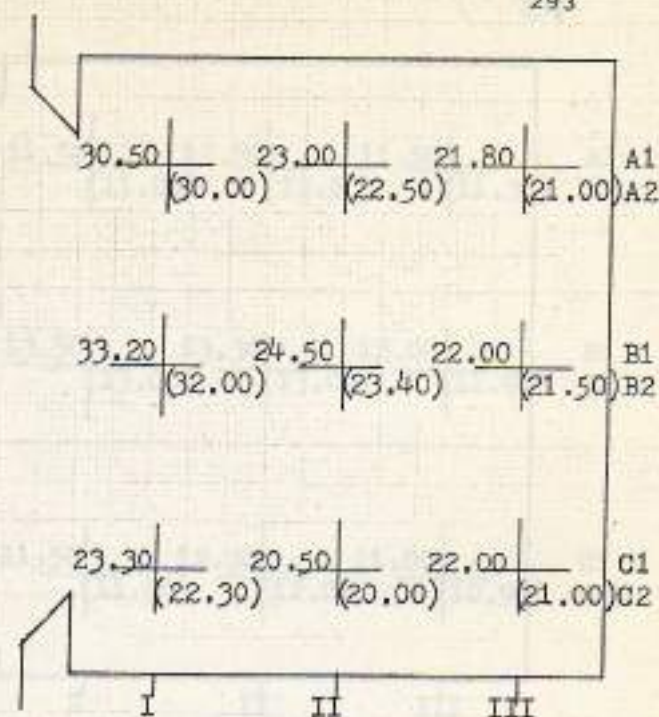

Reference points

Plan 1:50

Light source = ARTIFICIAL
 Readings = On work plane
 - - - - - = Model on lawn
 ———— = Model on concrete

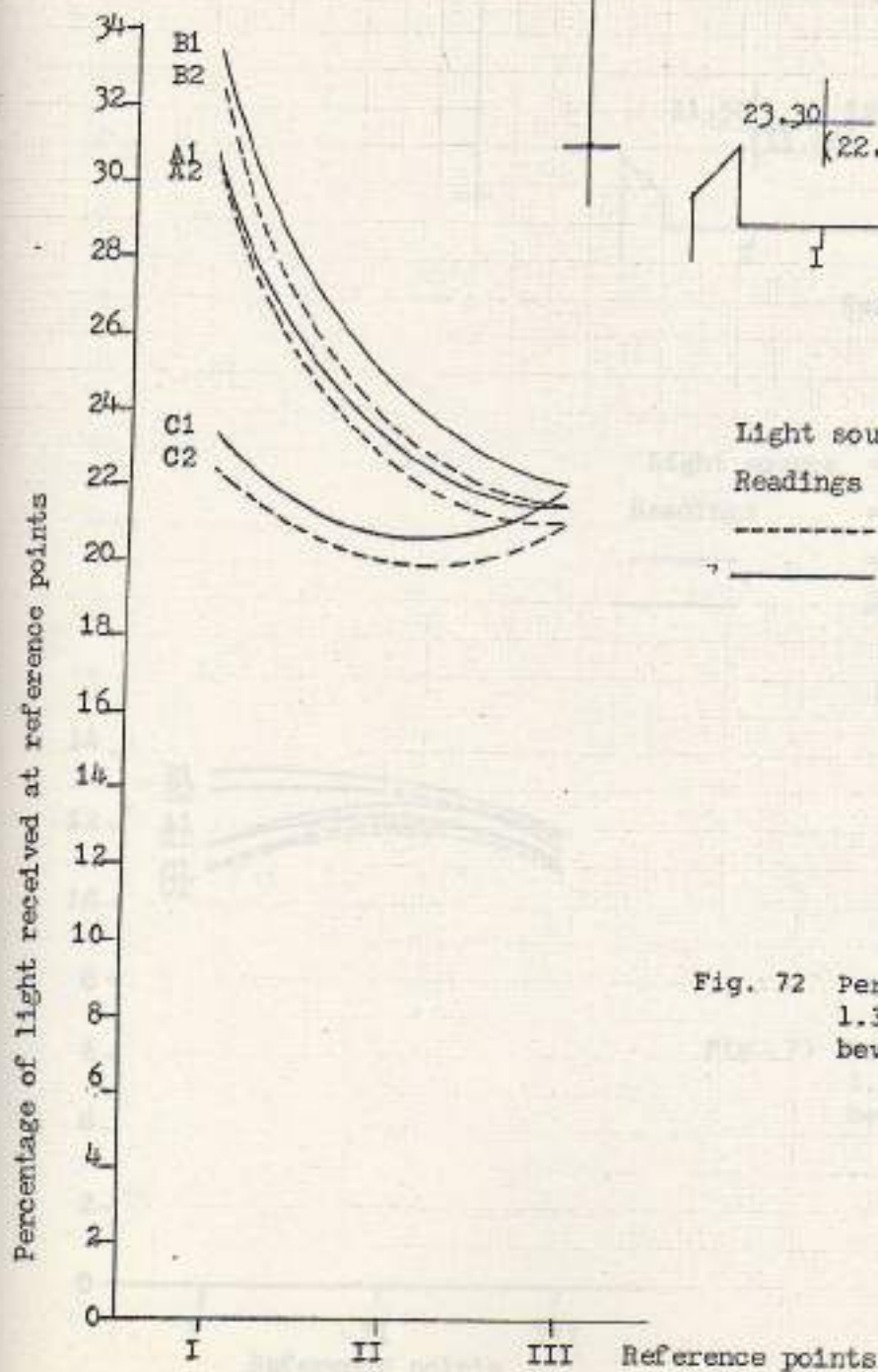
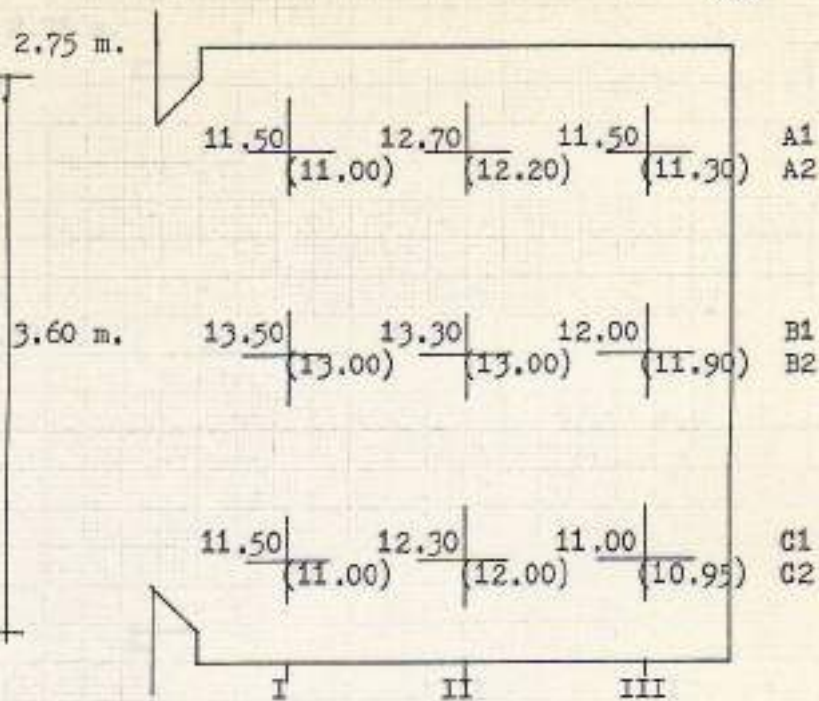

Fig. 72 Performance of window 3.00 x 1.30 Meters with reveals beveled to the exterior

Room = 4.00 x 3.50 x 2.75 m.

Window = 3.60 x 1.30 m.

Sill = 0.90 m.



Reference points

Plan 1:50

Light source = ARTIFICIAL

Readings = Work plane

----- = Model on lawn

———— = Model on lawn

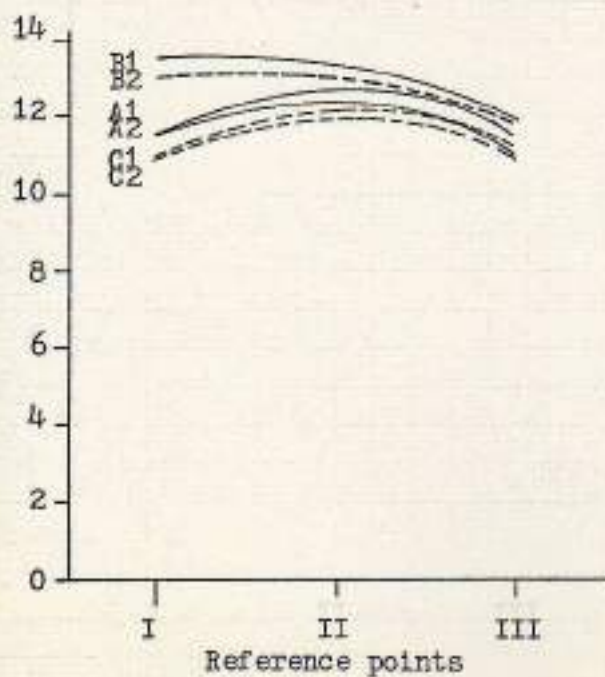
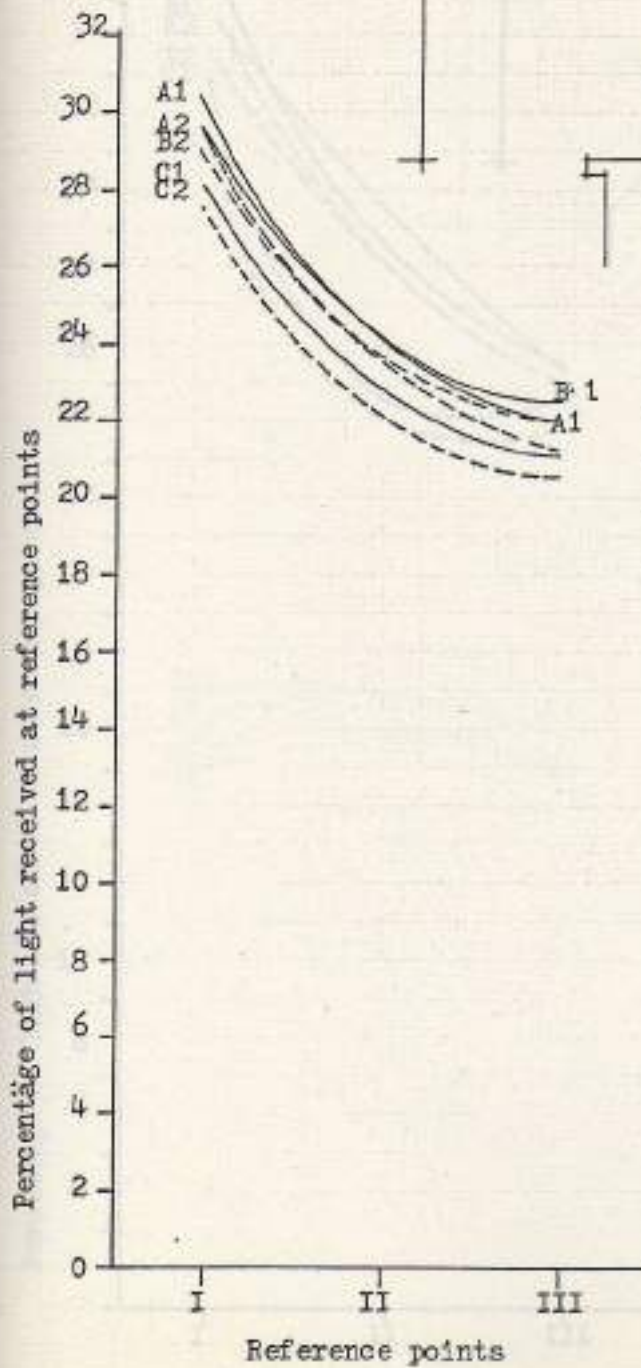
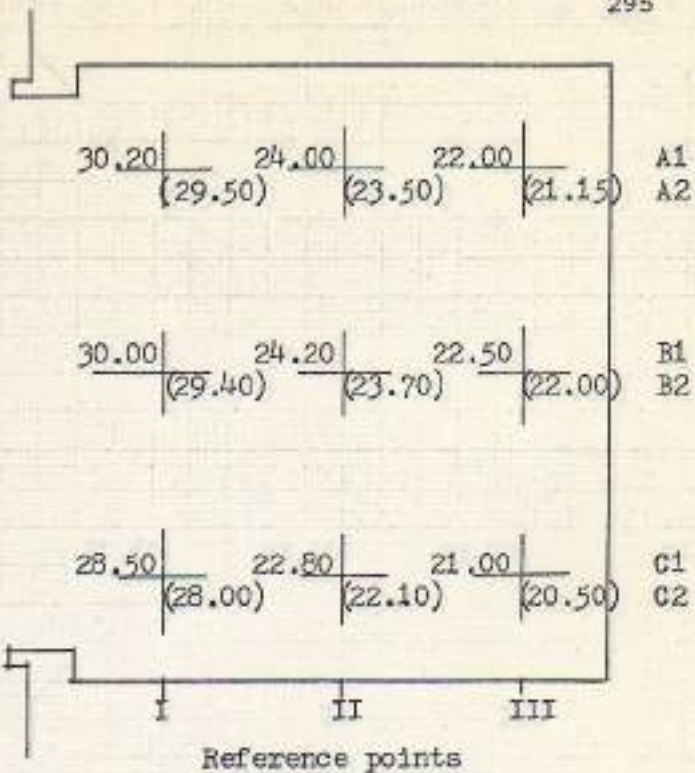

Fig. 73 Performance of window 3.60 x 1.30 Meters with reveals beveled to the interior

Room = 4.00 x 3.50 x 2.75 m.

Window = 3.60 x 1.30 m.

Sill = 0.90 m.



Light source = ARTIFICIAL
 Readings = On work plane
 ----- = Model on lawn
 _____ = Model on concrete

Plan 1:50

Fig. 74 Performance of window 3.60 x 1.30 Meters with square reveals

*Room = 4.00 x 3.50 x 2.75 m.
 Window = 3.60 x 1.30 m.
 Sill = 0.90 m.

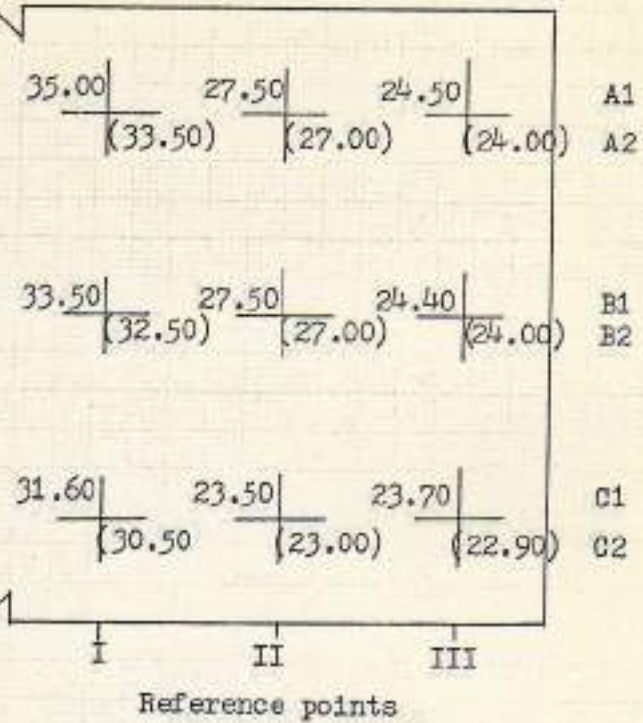
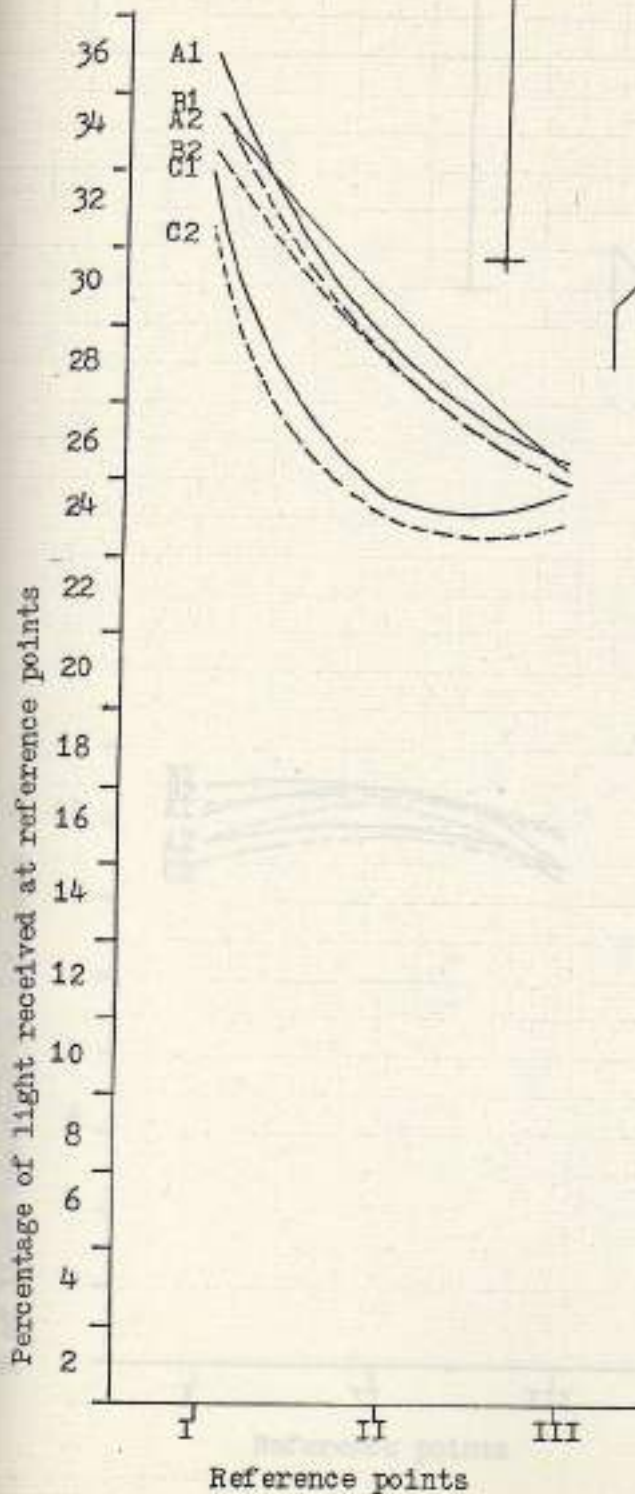

Plan 1:50

Light source = ARTIFICIAL
 Readings = On work plane
 ----- = Model on lawn
 _____ = Model on concrete

Fig. 75 Performance of window 3.60 x 1.30 Meters with square reveals

Fig. 75 Performance of window 3.60 x 1.30 Meters with square reveals

Room = 4.00 x 3.50 x 2.75 m.
 Window = 4.00 x 1.30 m.
 Sill = 0.90 m.

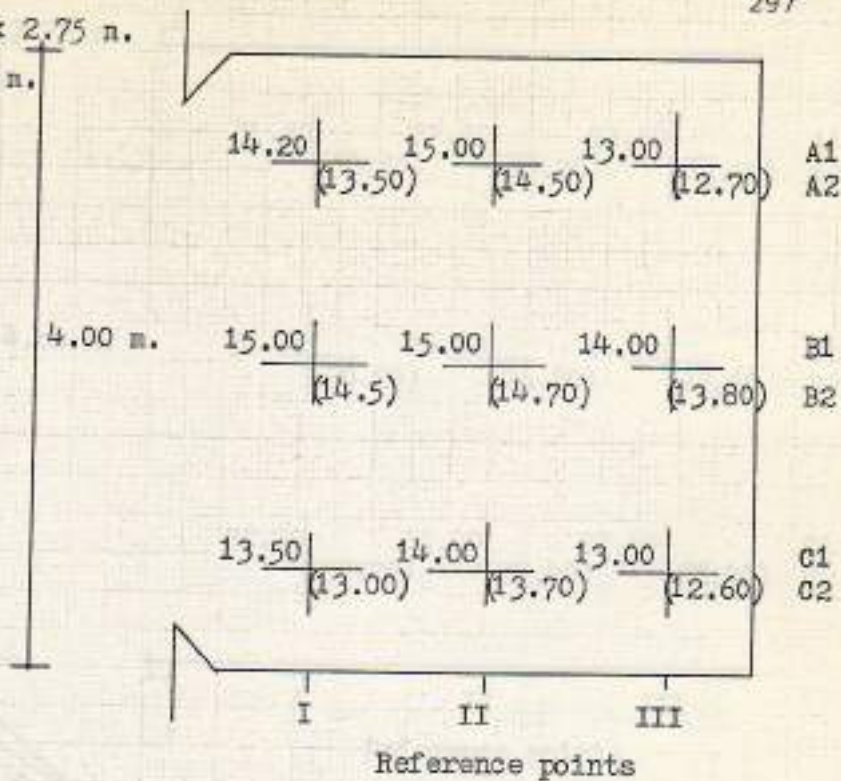

Plan 1:50

Light source = ARTIFICIAL
 Readings = On work plane
 - - - - - = Model on lawn
 ————— = Model on concrete

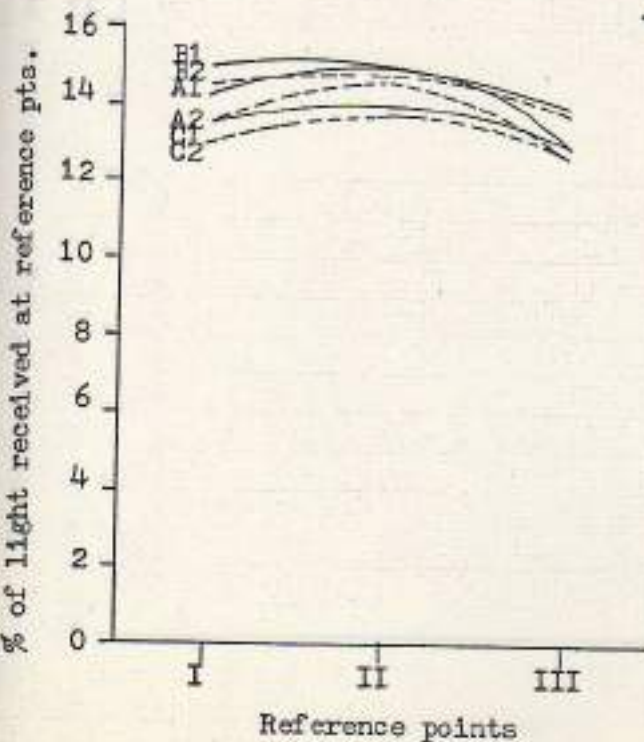

Fig. 76 Performance of window 4.00 x 1.30 Meters with reveals beveled to the interior

Room = 4.00 x 3.50 x 2.75 m.

Window = 4.00 x 1.30 m.

Sill = 0.90 m.

4.00 m.

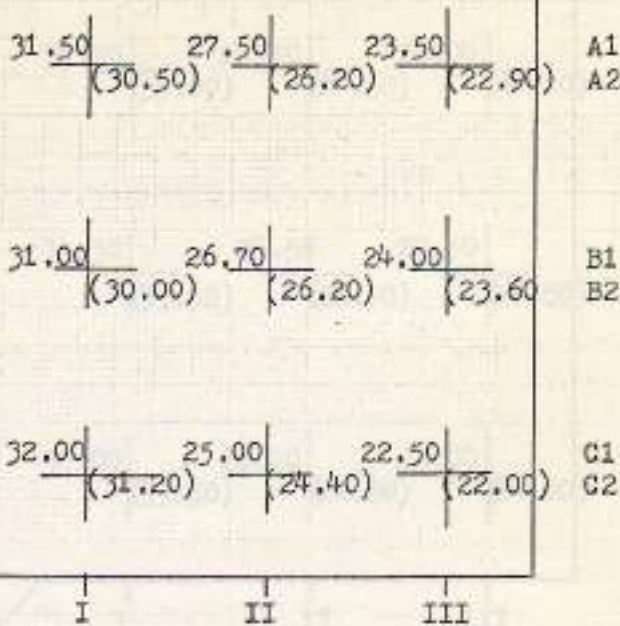

Reference points

Plan 1:50

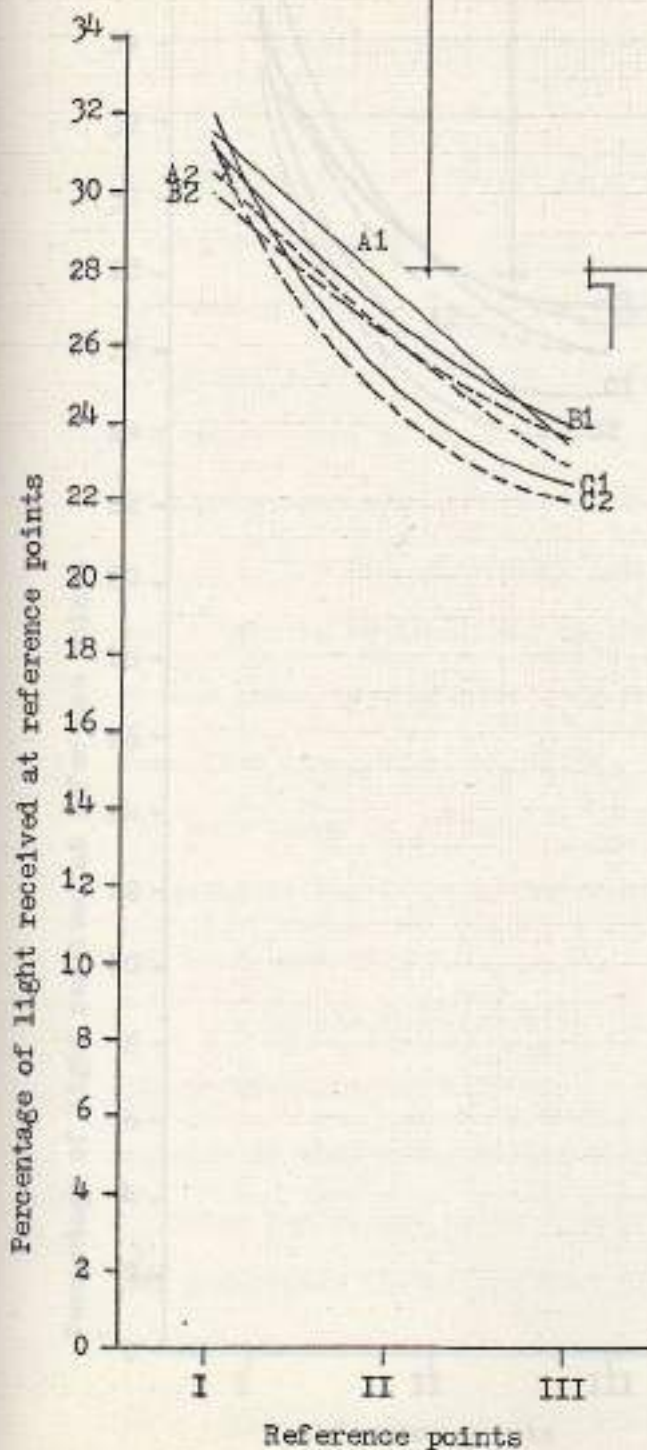

Fig. 77 Performance of window 4.00 x 1.30 Meters with square reveals

Room = 4.00 x 3.50 x 2.75 m.
 Window = 4.00 x 1.30 m.
 Sill = 0.90 m.

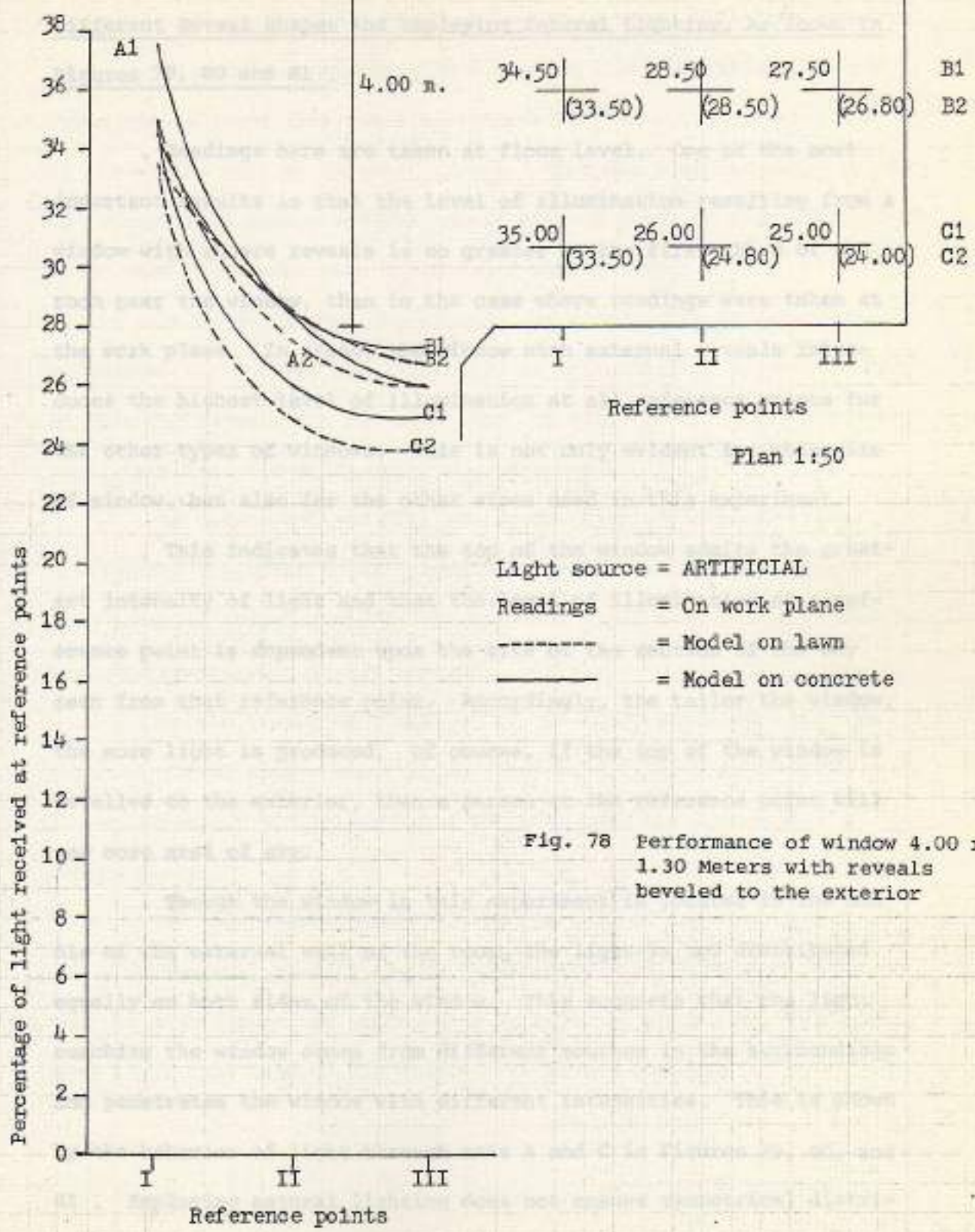

Fig. 78 Performance of window 4.00 x 1.30 Meters with reveals beveled to the exterior

Comparative Analysis Of The Level Of Illumination At The Floor Level Of Rooms Having Equal Window Sizes Of 1.20 x 1.30 Meters, But Having Different Reveal Shapes And Employing Natural Lighting, As Shown In Figures 79, 80 and 81 .

. Readings here are taken at floor level. One of the most important results is that the level of illumination resulting from a window with square reveals is no greater at the first third of the room near the window, than in the case where readings were taken at the work plane. In stead, the window with external reveals introduces the highest level of illumination at all reference points for the other types of windows. This is not only evident for this size of window, but also for the other sizes used in this experiment.

. This indicates that the top of the window admits the greatest intensity of light and that the level of illumination at a reference point is dependent upon the size of the section of the sky seen from that reference point. Accordingly, the taller the window, the more light is produced. Of course, if the top of the window is bevelled to the exterior, then a person at the reference point will see more area of sky.

. Though the window in this experiment is located in the middle of the external wall of the room, the light is not distributed equally on both sides of the window. This suggests that the light reaching the window comes from different sources in the surroundings and penetrates the window with different intensities. This is shown by the behavior of light through axis A and C in Figures 79, 80, and 81 . Employing natural lighting does not ensure symmetrical distri-

bution of light at both sides of the center lines of the window. The intensity of light is greater at the zenith than at the horizon, and the surroundings, variable though they may be, have different albedoes.

. At reference points AI and CI, the window with external reveals admits about five and a half times the light that is admitted by the window with an internal reveal. At these same reference points the window with square reveals admits between three to four times the light that the window with an internal reveal admits.

. At point BI near the window, the window with external reveals introduces three times the light that is introduced by the window with an internal reveal. At the same time, it gives about 20 percent more light than does the window with a square reveal.

. At points AII and CII, the window with an external reveal gives about three and a half times more light than the same window with internal reveals, and 34 percent more light than if the window was constructed with square reveals.

. At the center of the floor of the room, the window with an external reveal admits about three times more light than a window with internal reveals and 14 percent more light than the window with a square reveal.

. At the central point BIII of the rear of the room, the window with external reveals admits three and a half times more light than is admitted by the window with an internal reveal and 30 percent more light than that of the window with square reveals.

Room = 4.00 x 3.00 x 2.75 m.

Window = 1.20 x 1.70 m.

At the dimmest corners of the room at points AIII and CIII, the window with external reveals introduces about three times more light than is admitted from the window with internal reveals and about 25 percent more light than is admitted by the window with a square reveal.

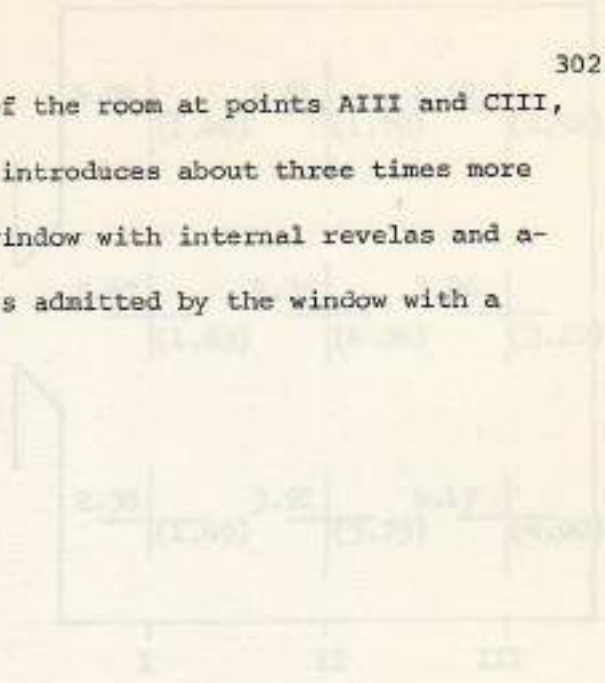

Reference points

Fig. 25

- Light source = SUN
- Headings = on floor level
- = field of view
- = total illuminance

Fig. 25 Performance of window with a 1.20-meters with reveals located to the interior with respect to the floor level.



Reference points

Room = 4.00 x 3.50 x 2.75 m.

Window = 1.20 x 1.30 m.

Sill = 0.90 m.

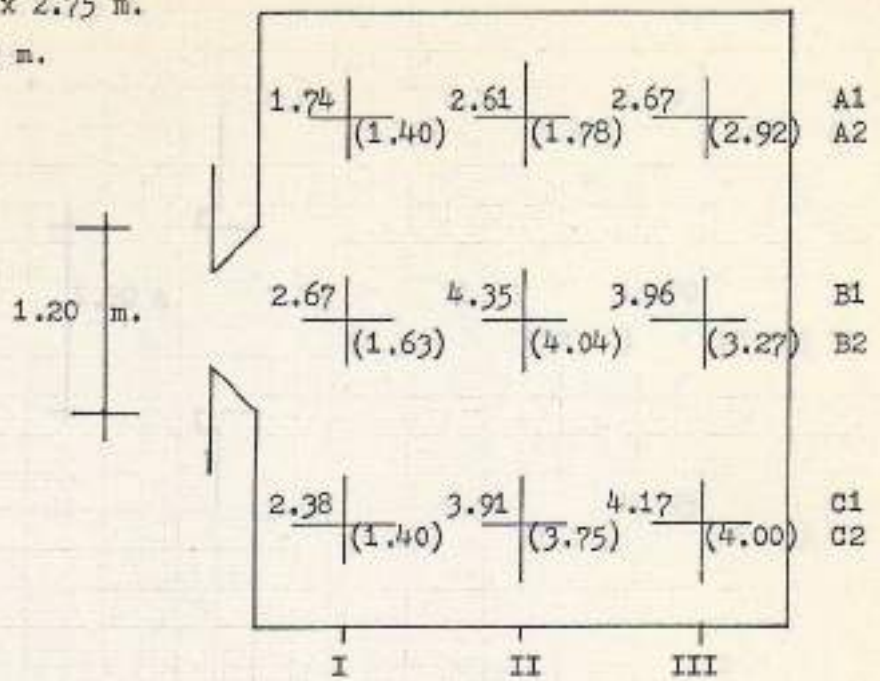

Reference points

Plan 1:50

Light source = NATURAL

Readings = on floor level

----- = Model on lawn

————— = Model on concrete

Fig. 79. Performance of window 1.20 x 1.30 Meters with reveals beveled to the interior with respect to the floor level

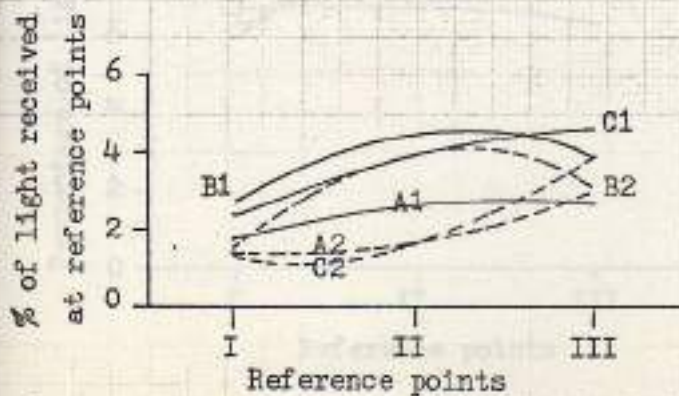

Room = 4.00 x 3.50 x 2.75 m.

Window = 1.20 x 1.30 m.

Sill = 0.90 m.

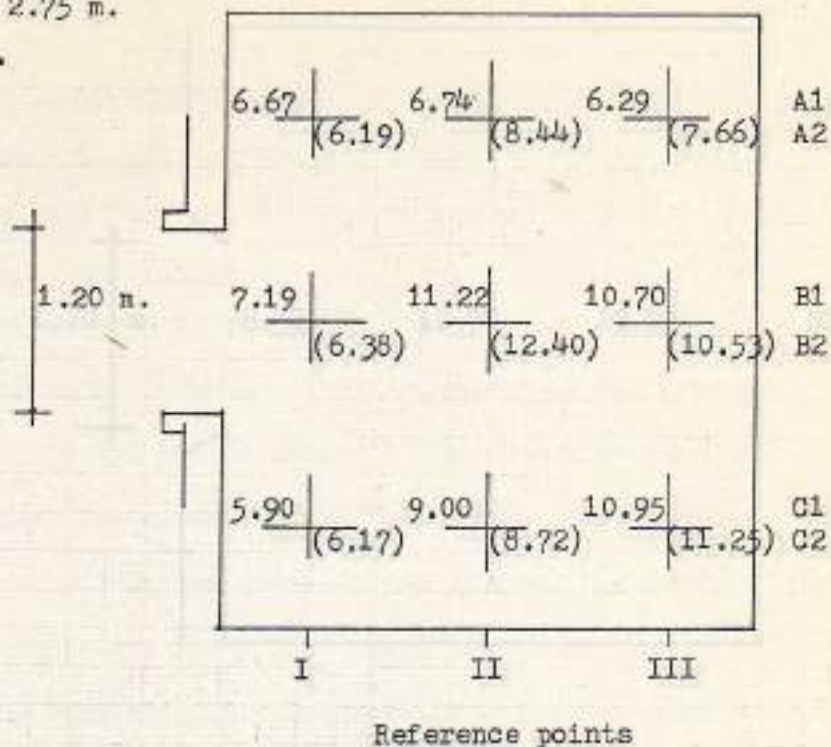

Plan 1:50

- Light source = NATURAL
- Readings = On floor level
- = Model on lawn
- = Model on concrete

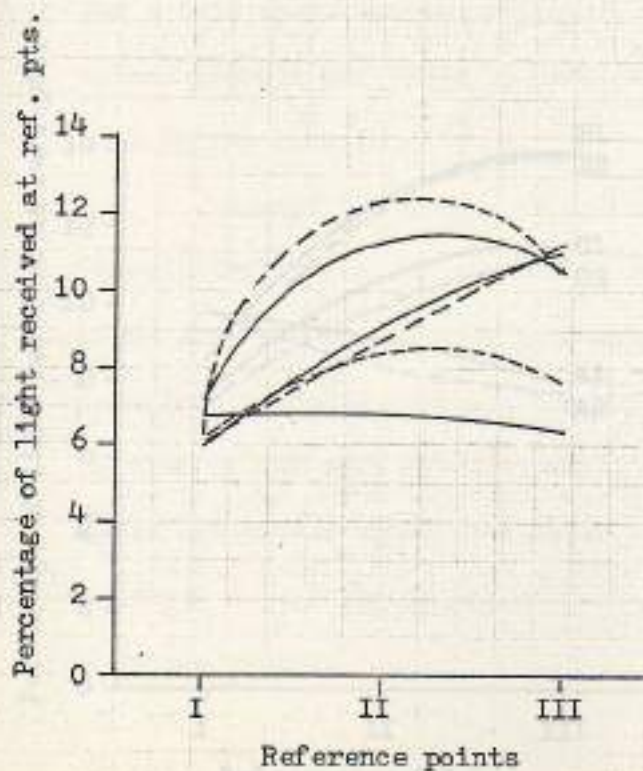
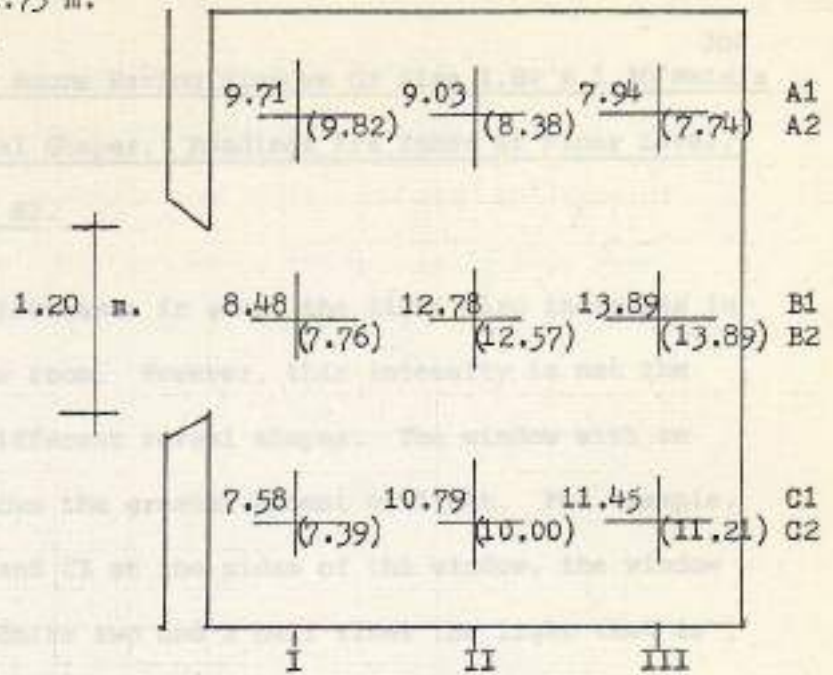

Fig. 80 Performance of window 1.20 x 1.30 Meters with square reveals

Room = 4.00 x 3.50 x 2.75 m.

Window = 1.20 x 1.30 m.

Sill = 0.90 m.



Reference points

Plan 1:50

Light source = NATURAL

Readings = On floor level

----- = Model on lawn

————— = Model on concrete

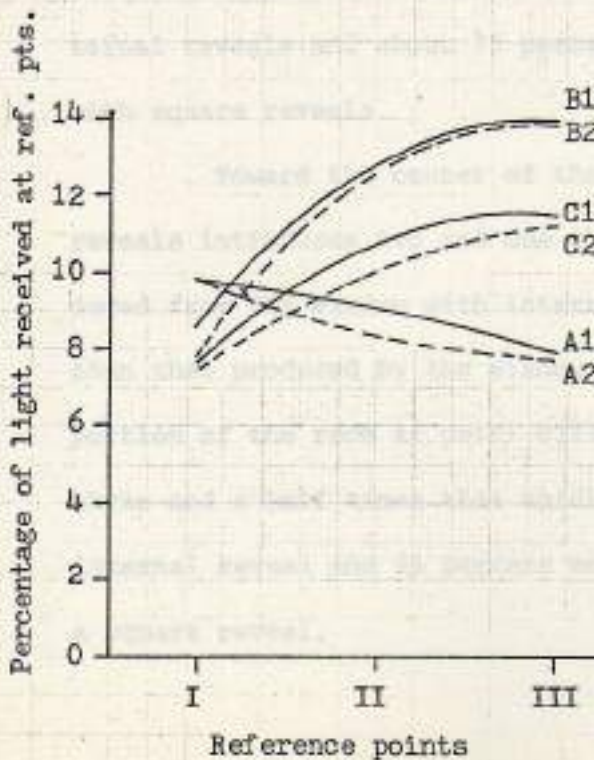

Fig. 81 Performance of window 1.20 x 1.30 Meters with external reveals

Comparative Analysis Of Rooms Having Windows Of Size 1.80 x 1.30 Meters
But With Different Reveal Shapes. Readings Are Taken At Floor Level.
See Figures 82, 83, and 83.

. As the window increases in size, the light also increases in intensity throughout the room. However, this intensity is not the same for windows with different reveal shapes. The window with an external reveal introduces the greater amount of light. For example, at reference points AI and CI at the sides of the window, the window with external reveals admits two and a half times the light that is admitted from the window with the internal reveals, while the same window being constructed with square reveals introduces only twice the light that is admitted by the window with internal reveals.

. At point BI near the center of the window, the window with external reveals exhibits a superior performance. It admits three and a half times the light that is introduced by the window with internal reveals and about 75 percent more light than does the window with square reveals.

. Toward the center of the room, the window with external reveals introduces two and one third times more light than is introduced from the window with internal reveals, and 14 percent more than that produced by the window with a square reveal. At the rear portion of the room at point BIII, this window introduces about three and a half times that which is admitted by the window with an internal reveal and 25 percent more light than from the window with a square reveal.

. At the corners of the room, at points AIII and CIII, the light admitted from the window with external reveals is about three times the light that is admitted from the window with an internal revela, while the window with the square reveal admits less than two and a half times the light that is admitted by the latter.

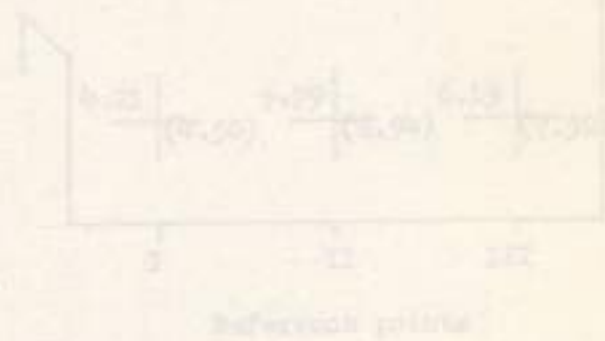

Light source - NATURAL
 Readings - On floor level
 ———— - Noted on floor
 ———— - Noted on concrete

Fig. 32 Performance of window 1.20 x 1.20 meters having reveals leveled to the interior



Room = 4.00 x 3.50 x 2.75 m.

Window = 1.80 x 1.30 m.

Sill = 0.90 m.

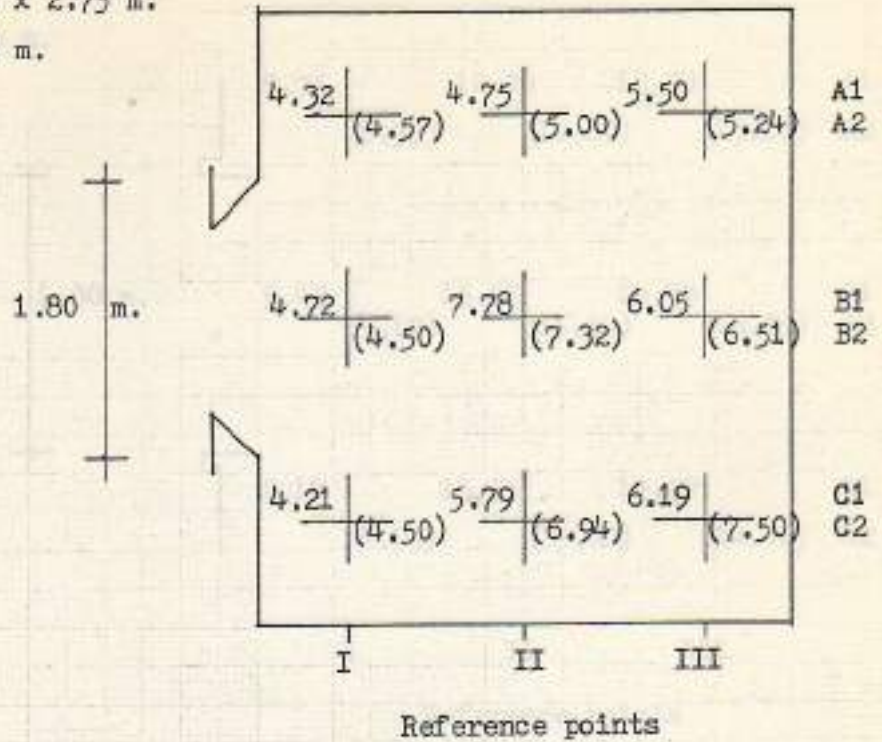

Plan 1:50

Light source = NATURAL

Readings = On floor level

----- = Model on lawn

————— = Model on concrete

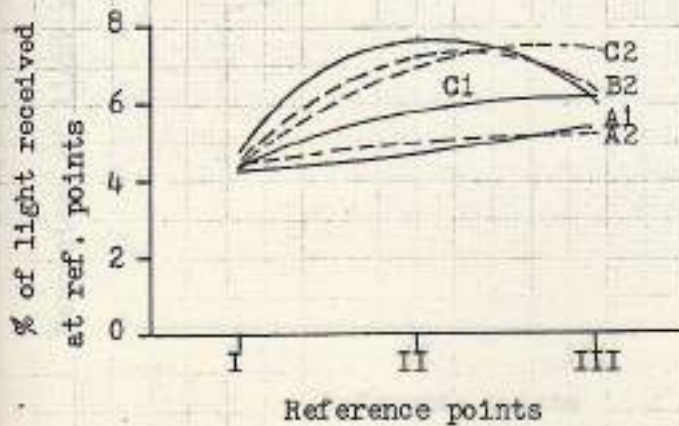

Fig. 82 Performance of window 1.80 x 1.30 Meters having reveals beveled to the interior

Room = 4.00 x 3.50 x 2.75 m.

Window = 1.80 x 1.30 m.

Sill = 0.90 m.

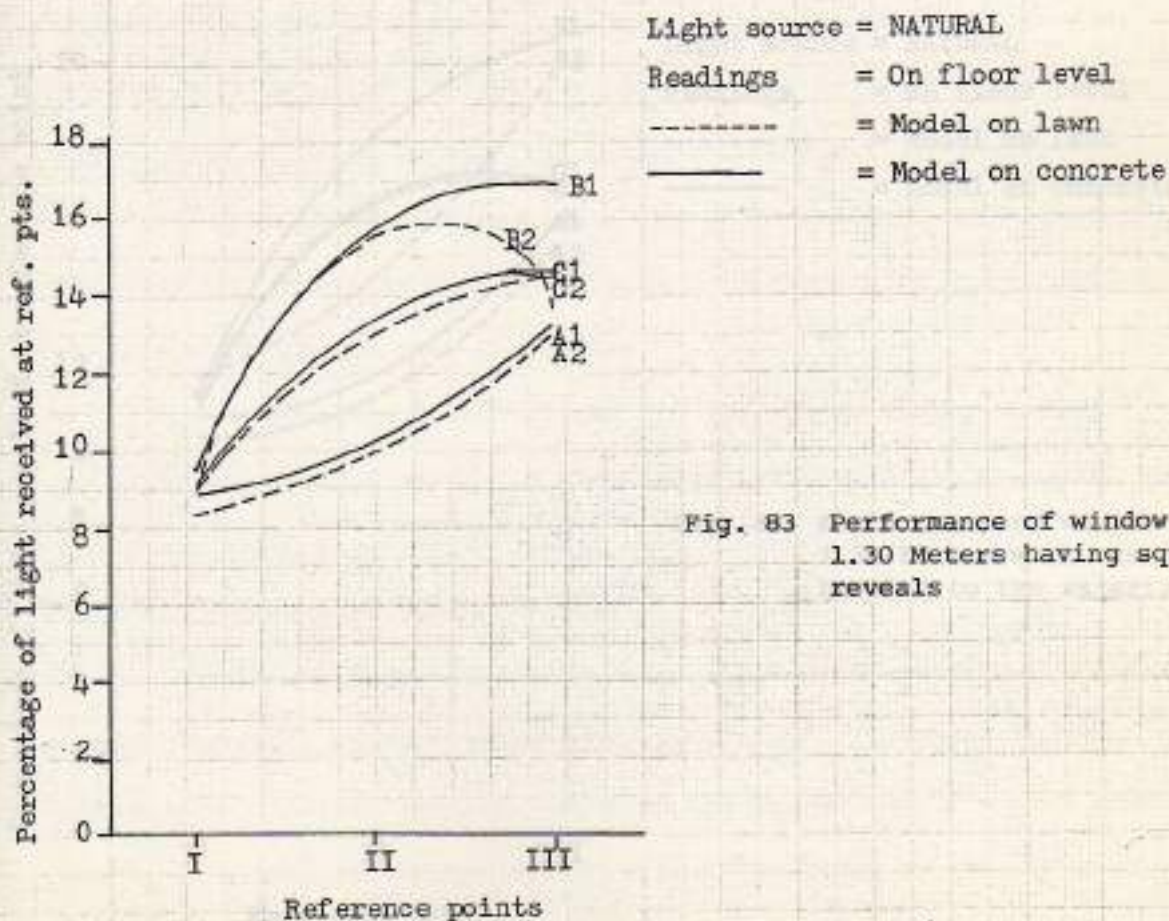
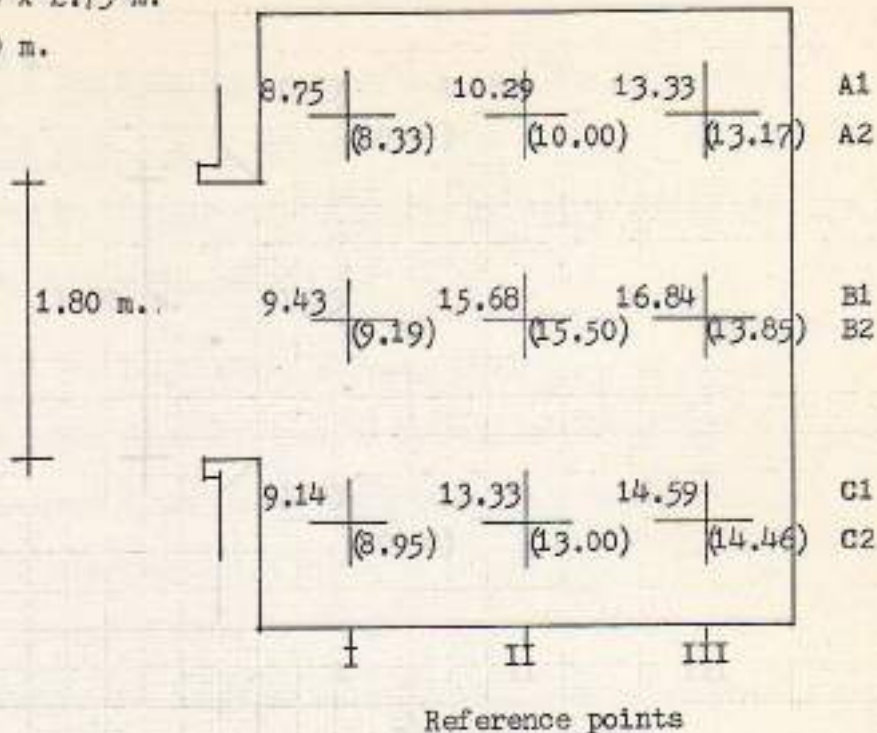
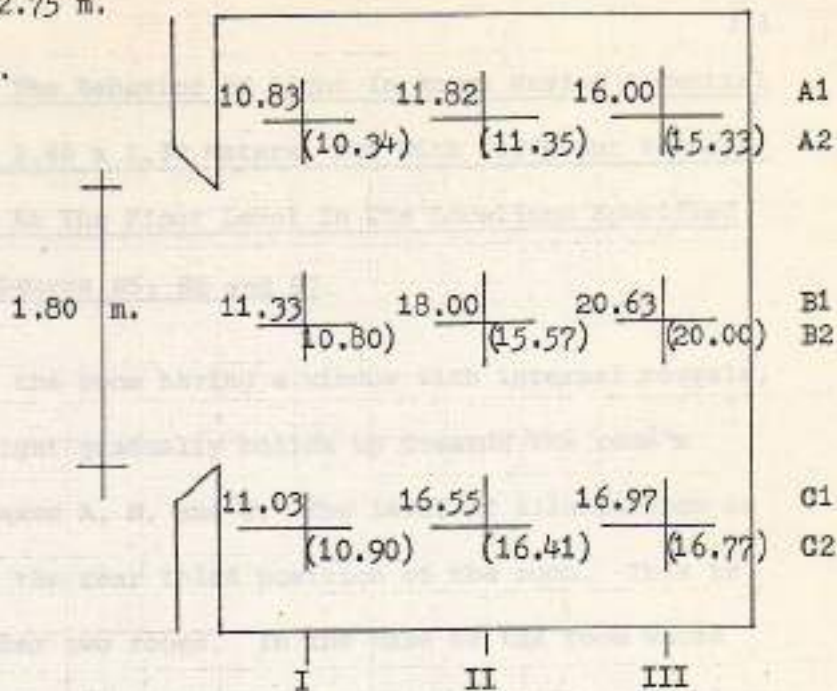

Fig. 83 Performance of window 1.80 x 1.30 Meters having square reveals

Room = 4.00 x 3.50 x 2.75 m.

Window = 1.80 x 1.30 m.

Sill = 0.90 m.



Reference points

Plan 1:50

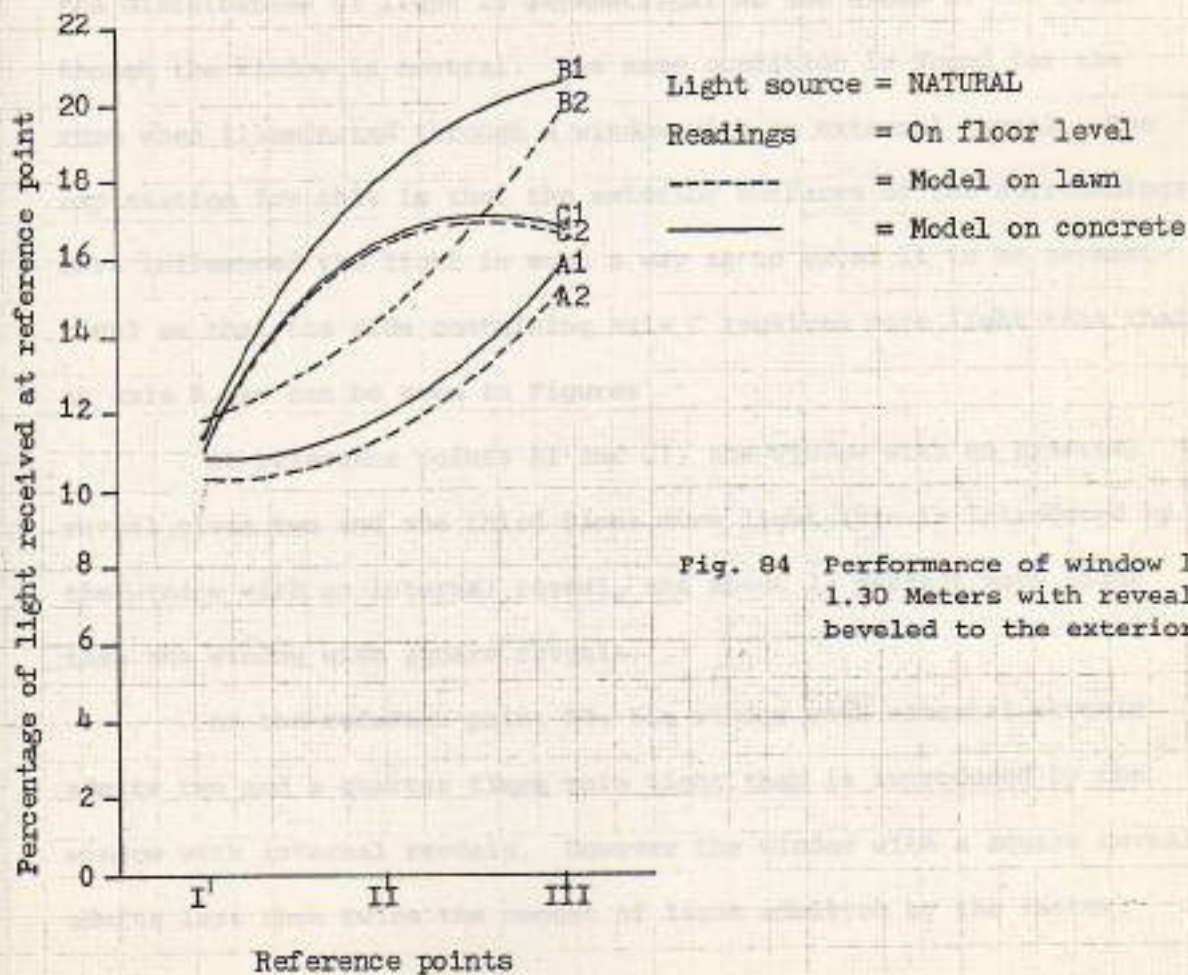

Fig. 84 Performance of window 1.80 x 1.30 Meters with reveals beveled to the exterior

Comparative Analysis Of The Behavior Of Light In Rooms Having A Central Window With The Size Of 2.40 x 1.30 Meters, But With Different Reveals. Measurements Were Taken At The Floor Level In The Locations Specified In The Drawings. See Figures 85, 86 and 87.

. In the case of the room having a window with internal reveals, as seen in Figure 85 light gradually builds up towards the room's center with respect to axes A, B, and C. The level of illumination is relatively constant for the rear third position of the room. This is not the case for the other two rooms. In the case of the room whose window has square reveals, the increase in illumination is remarkably varied for the three axes perpendicular to the window, Figure 86 and the distribution of light is asymmetrical at the sides of the room, though the window is central. The same condition is found for the room when illuminated through a window with an external reveal. The explanation for this is that the exterior surfaces of the surroundings have influenced the light in such a way as to cause it to be asymmetrical so that the side containing axis C receives more light than that at axis A, as can be seen in Figures

. At reference points AI and CI, the window with an external reveal gives two and one third times more light than is introduced by the window with an internal reveal, and about 23 percent more light than the window with square reveals.

. At the reference point BI, the window with external reveals admits two and a quarter times more light than is introduced by the window with internal reveals. However the window with a square reveal admits less than twice the amount of light admitted by the latter.

Room = 4.00 x 3.30 = 13.23 m.

Window = 2.40 x 1.30 m.

. At the remote corners of the room, at points AIII and CIII the window with internal reveals admits two and two third times more light than that which is admitted by the window with internal reveals. The window with square reveals admits about twice the light that the window with an internal reveal does.

. At point BIII along the axis of the window, near the rear wall, the window with external reveals introduces about three times the light that is admitted by the window with internal reveals. The window with square reveals admits only two and a quarter times the light that the latter admits.

- Light source = SUN
- Seatings = On floor level
- = Metal on glass
- = Metal on concrete

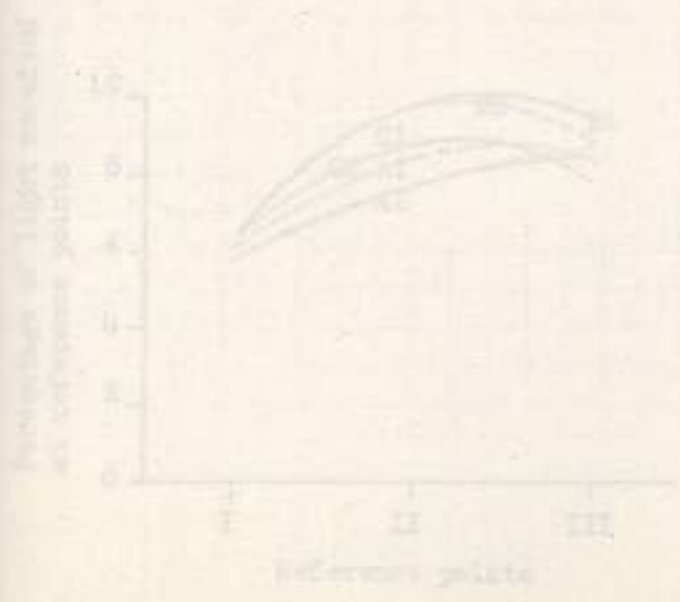
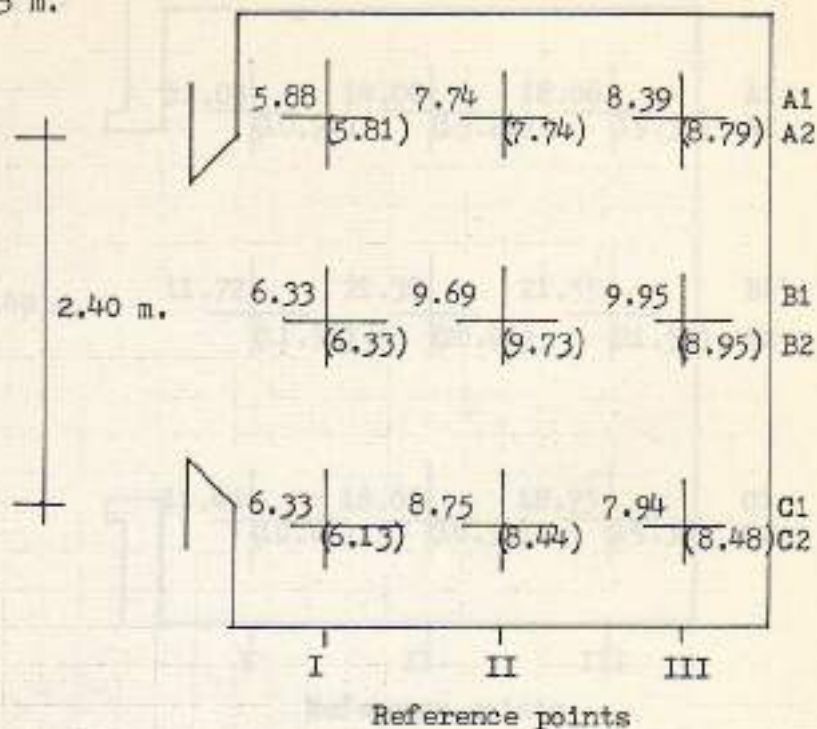

Fig. 23 Performance of window 2.40 x 1.30 meters having reveals revealed on the interior

Room = 4.00 x 3.50 x 2.75 m.

Window = 2.40 x 1.30 m.

Sill = 0.90m.



Plan 1.:50

Light source = NATURAL
 Readings = On floor level
 ----- = Model on lawn
 _____ = Model on concrete

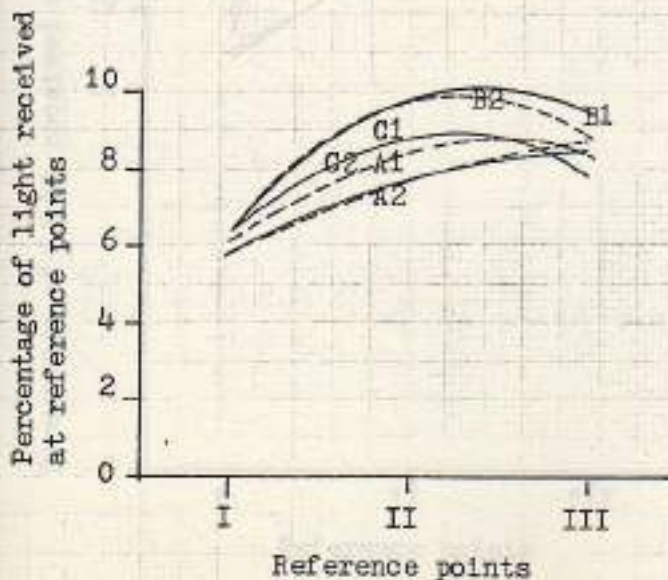
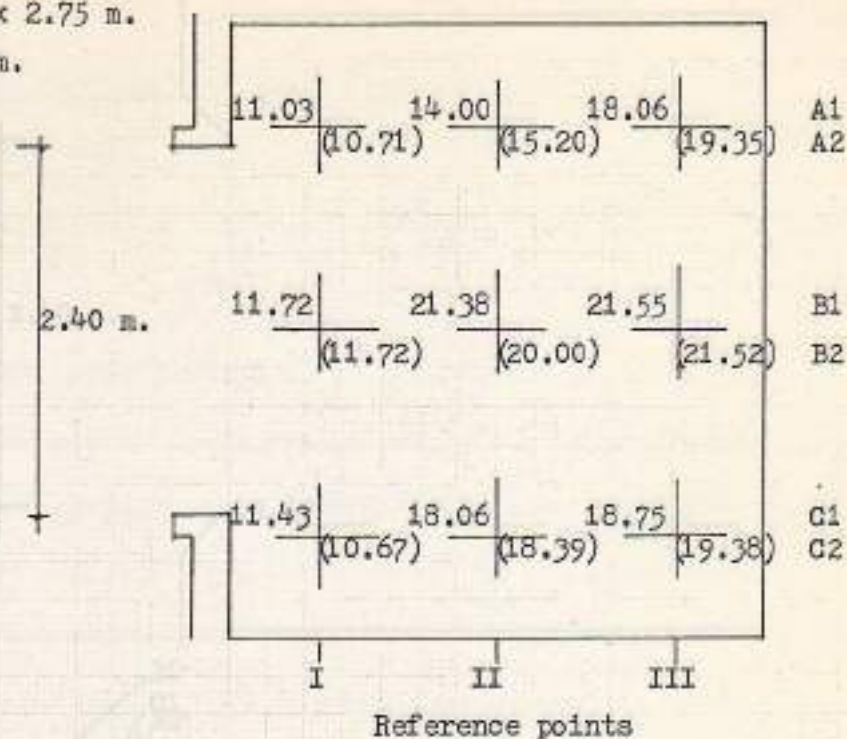

Fig. 85 Performance of window 2.40 x 1.30 Meters having reveals beveled to the interior

Room = 4.00 x 3.50 x 2.75 m.

Window = 2.40 x 1.30 m.

Sill = 0.90 m.



Plan 1:50

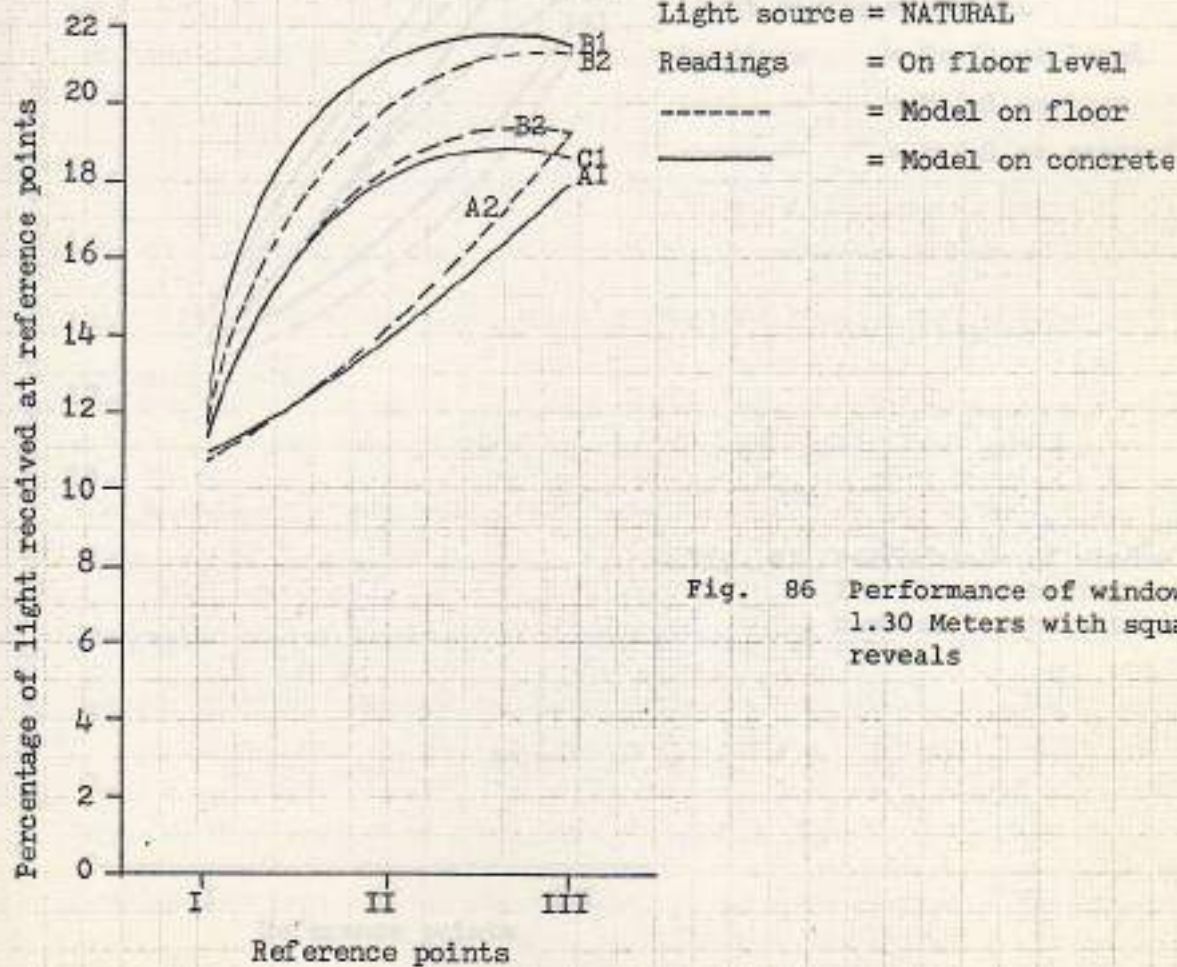
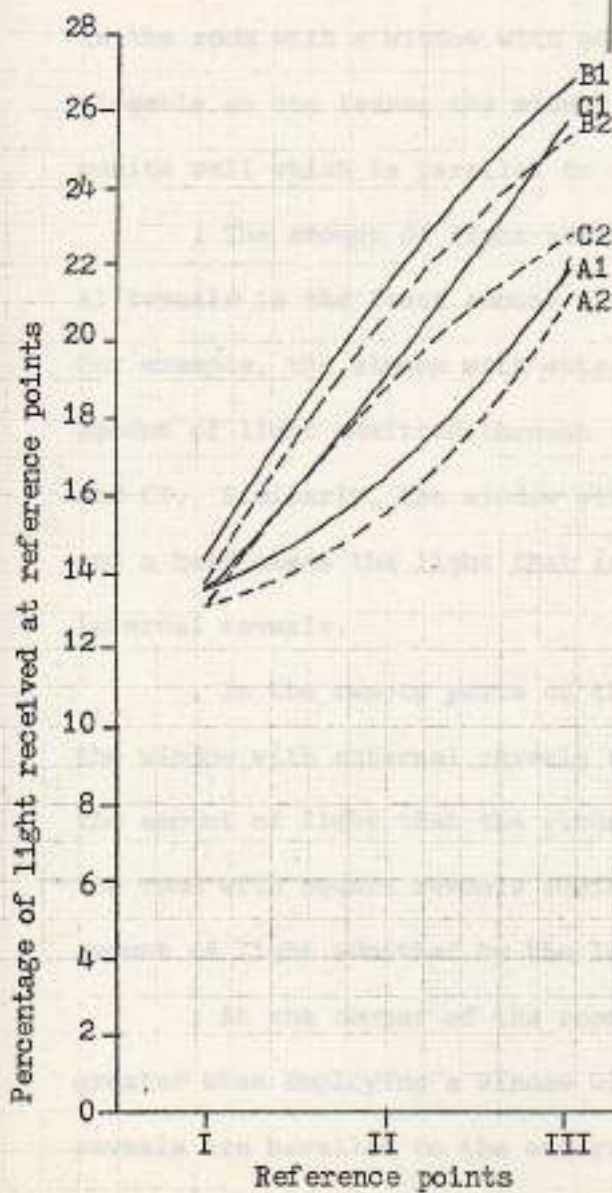
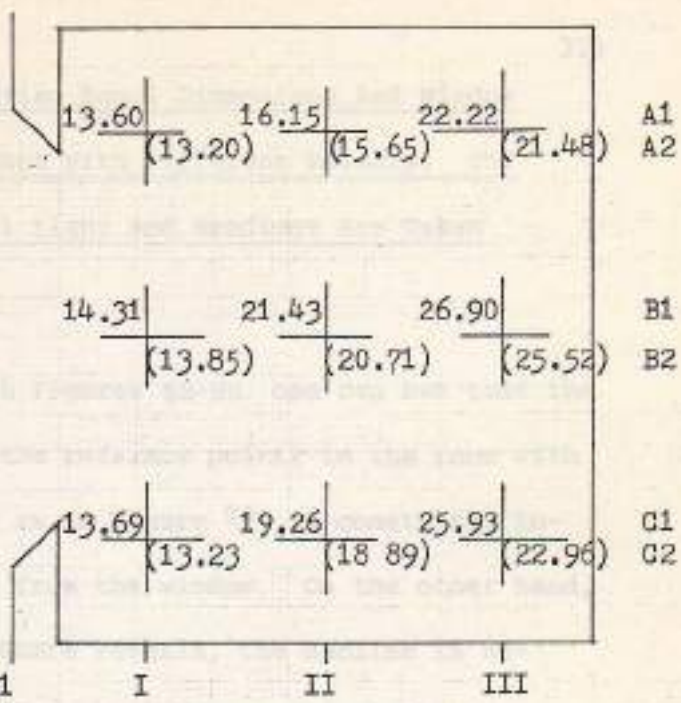
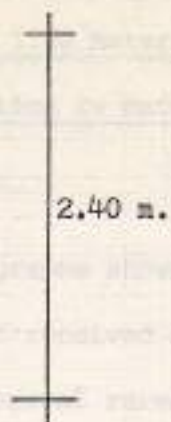

Fig. 86 Performance of window 2.40 x 1.30 Meters with square reveals

Room = 4.00 x 3.50 x 2.75 m.

Window = 2.40 x 1.30 m.

Sill = 0.90 m.



Light source = NATURAL
 Readings = On floor level
 ----- = Model on lawn
 _____ = Model on concrete

Fig. 87 Performance of window 2.40 x 1.30 Meters having reveals beveled to the exterior

Comparative Analysis Of Rooms Having Equal Dimensions And Window Openings of 3.00 x 1.30 Meters, But With Different Reveals. The Source Of Illumination Is Natural Light And Readings Are Taken At The Floor Level.

. From the graphs shown in Figures 88-90, one can see that the percentage of light received at the reference points in the room with a window having external reveals as in Figure 90, is constantly increasing with increased distance from the window. On the other hand, in the room with a window with square reveals, the decline is noticeable as one leaves the middle of the room, approaching the opposite wall which is parallel to the window.

. The amount of light admitted through the window with internal reveals is the least amount when compared to the other two cases. For example, the window with external reveals admits about twice the amount of light admitted through the latter at reference points AI and CI. Similarly, the window with square reveals admits only one and a half times the light that is admitted through the window with internal reveals.

. In the remote parts of the room at points AIII and CIII the window with external reveals admits about two and a half times the amount of light that the window with internal reveals admits. The room with square reveals admits a slightly more than twice the amount of light admitted by the latter.

. At the center of the room the level of illumination is greater when employing a window with square reveals than when the reveals are bevelled to the exterior or to the interior. This con-

condition did not occur when artificial light was employed. (This suggests that the movement of the sun in the sky creates a variation of reflections. However, these experiments were performed under totally overcast skies and within a limited time framework.) Nevertheless, for the reference points other than this point, the level of illumination remained less than those illuminated by the window with the external reveals.



Fig. 75 Performance of window 1.70 x 1.10 meters having reveals located on the interior



Fig. 76 Performance of window 1.70 x 1.10 meters having reveals located on the exterior

Room = 4.00 x 3.50 x 2.75 m.

Window = 3.00 x 1.30 m.

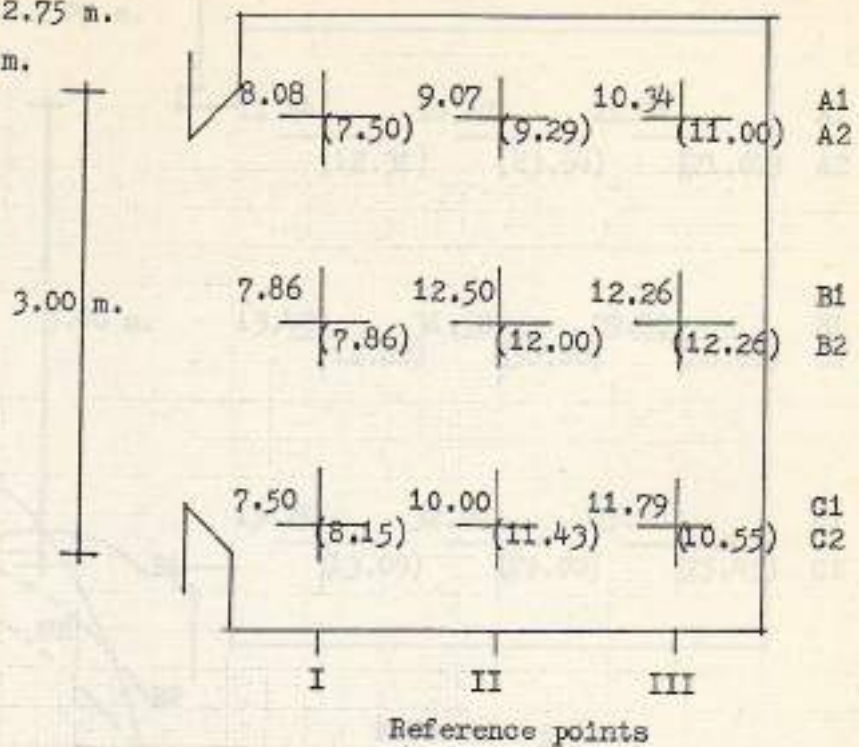

Plan 1:50

- Light source = NATURAL
- Readings = On floor level
- = Model on lawn
- = Model on concrete

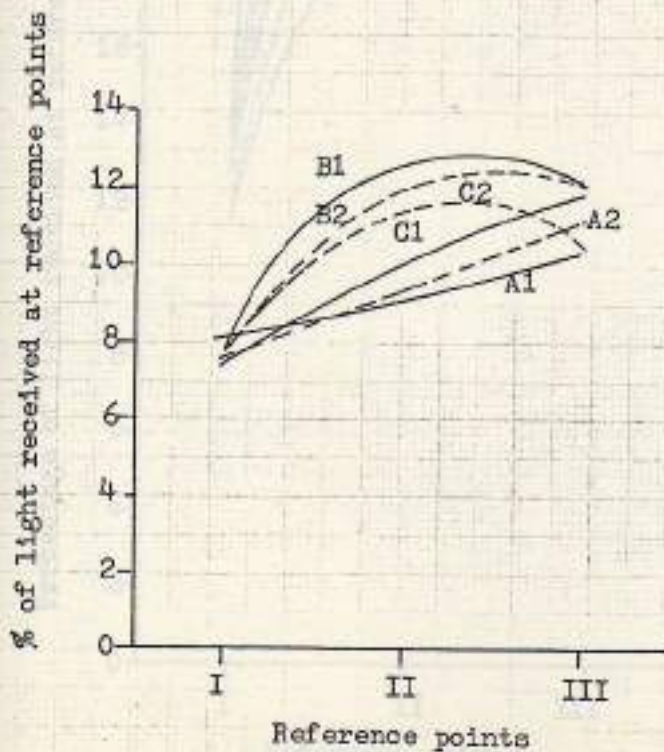

Fig. 88 Performance of window 3.00 x 1.30 Meters having reveals beveled to the interior

Room = 4.00 x 3.50 x 2.75 m.

Window = 3.00 x 1.30 m.

Sill = 0.90 m.

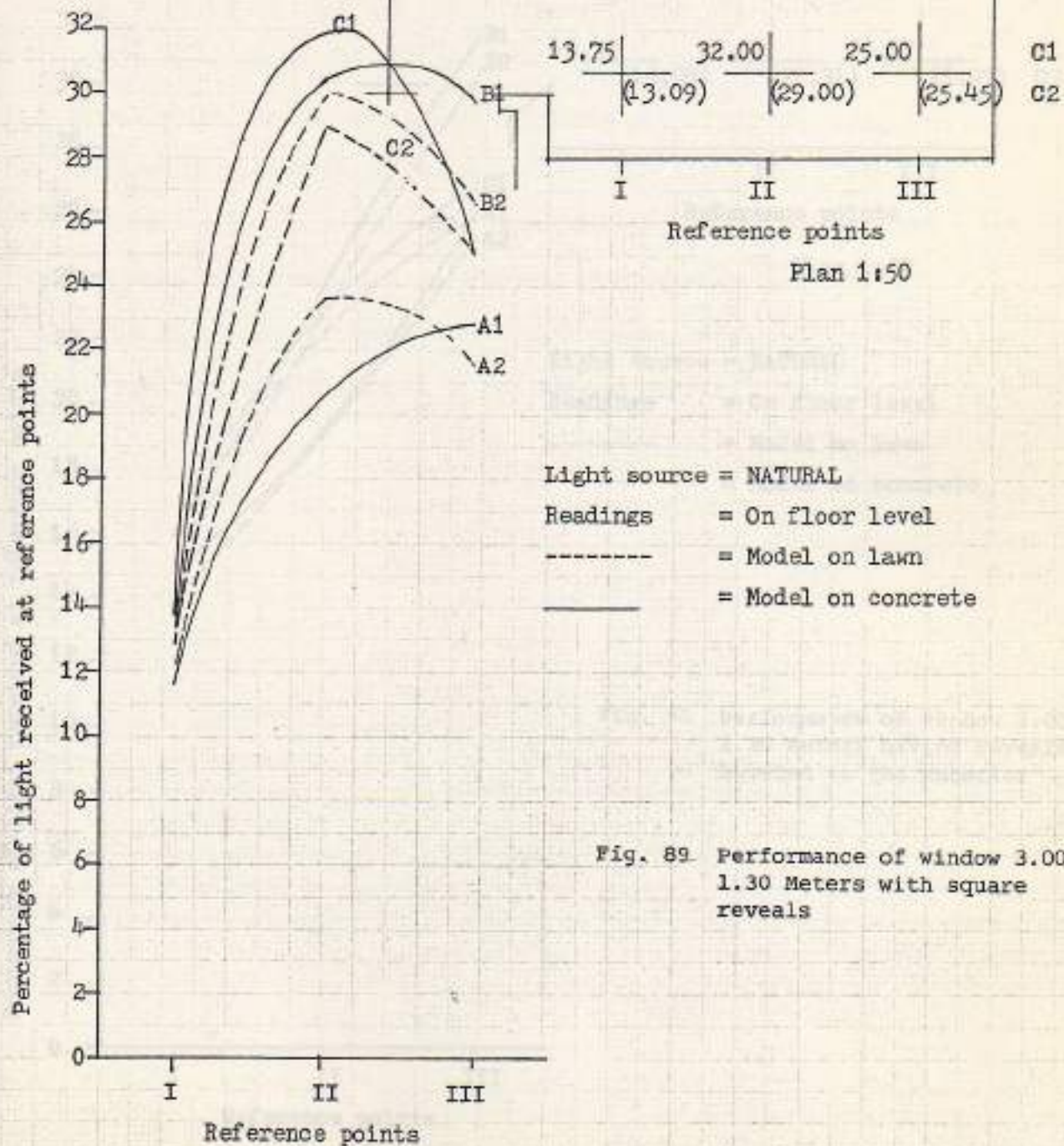

Fig. 89 Performance of window 3.00 x 1.30 Meters with square reveals

Room = 4.00 x 3.50 x 2.75 m.

Window = 3.00 x 1.30 m.

Sill 0.90 m.

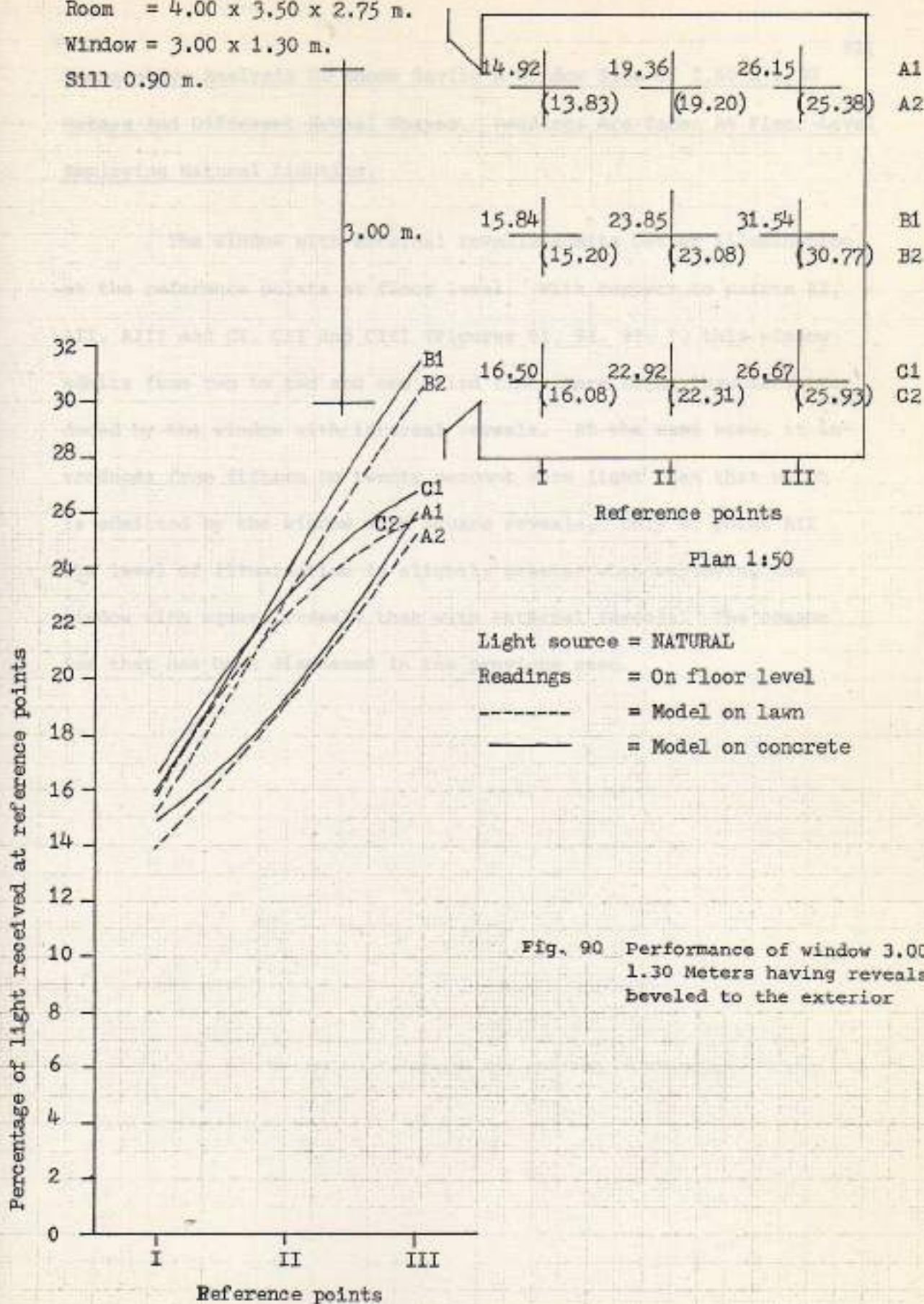

Fig. 90 Performance of window 3.00 x 1.30 Meters having reveals beveled to the exterior

Comparative Analysis Of Rooms Having A Window Size Of 3.60 x 1.30

Meters And Different Reveal Shapes. Readings Are Taken At Floor Level
Employing Natural Lighting.

. The window with external reveals admits better illumination at the reference points at floor level. With respect to points AI, AII, AIII and CI, CII and CIII (Figures 91, 92, 93.), this window admits from two to two and one third times more light than is introduced by the window with internal reveals. At the same time, it introduces from fifteen to twenty percent more light than that which is admitted by the window with square reveals. Only at point AII the level of illumination is slightly greater when employing the window with square reveals than with external reveals. The reason for that has been discussed in the previous case.



Fig. 91 Performance of window 3.60 x 1.30 meters with reveals opening to the interior with respect to the floor level.

Room = 4.00 x 3.50 x 2.75 m.
 Window = 3.60 x 1.30 m.
 Sill = 0.90 m.

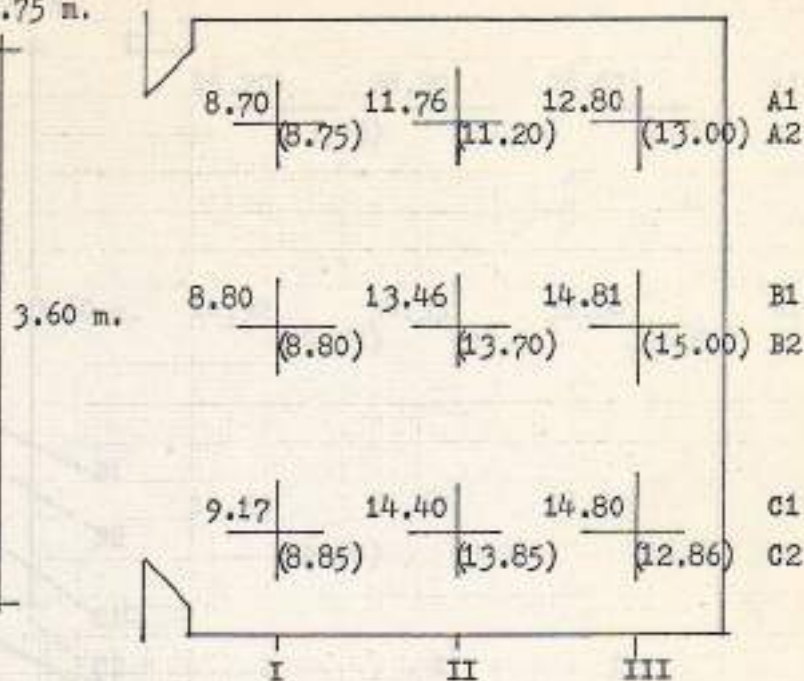

Reference points

Plan 1:50

Light source = NATURAL
 Readings = On floor level
 ----- = Model on lawn
 ————— = Model on concrete

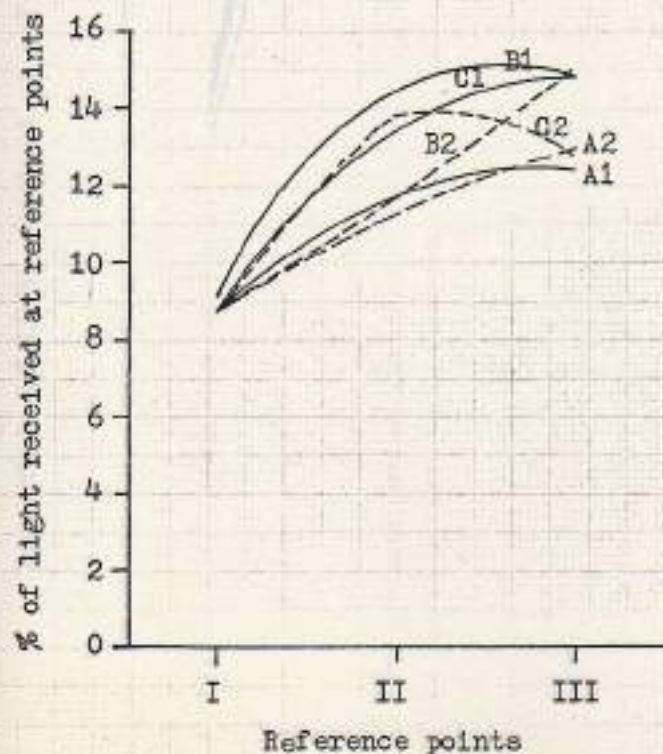

Fig. 91 Performance of window
 3.60 x 1.30 Meters with
 reveals beveled to the
 interior with respect
 to the floor level

Room = 4.00 x 3.50 x 2.75 m.
 Window = 3.60 x 1.30 m.

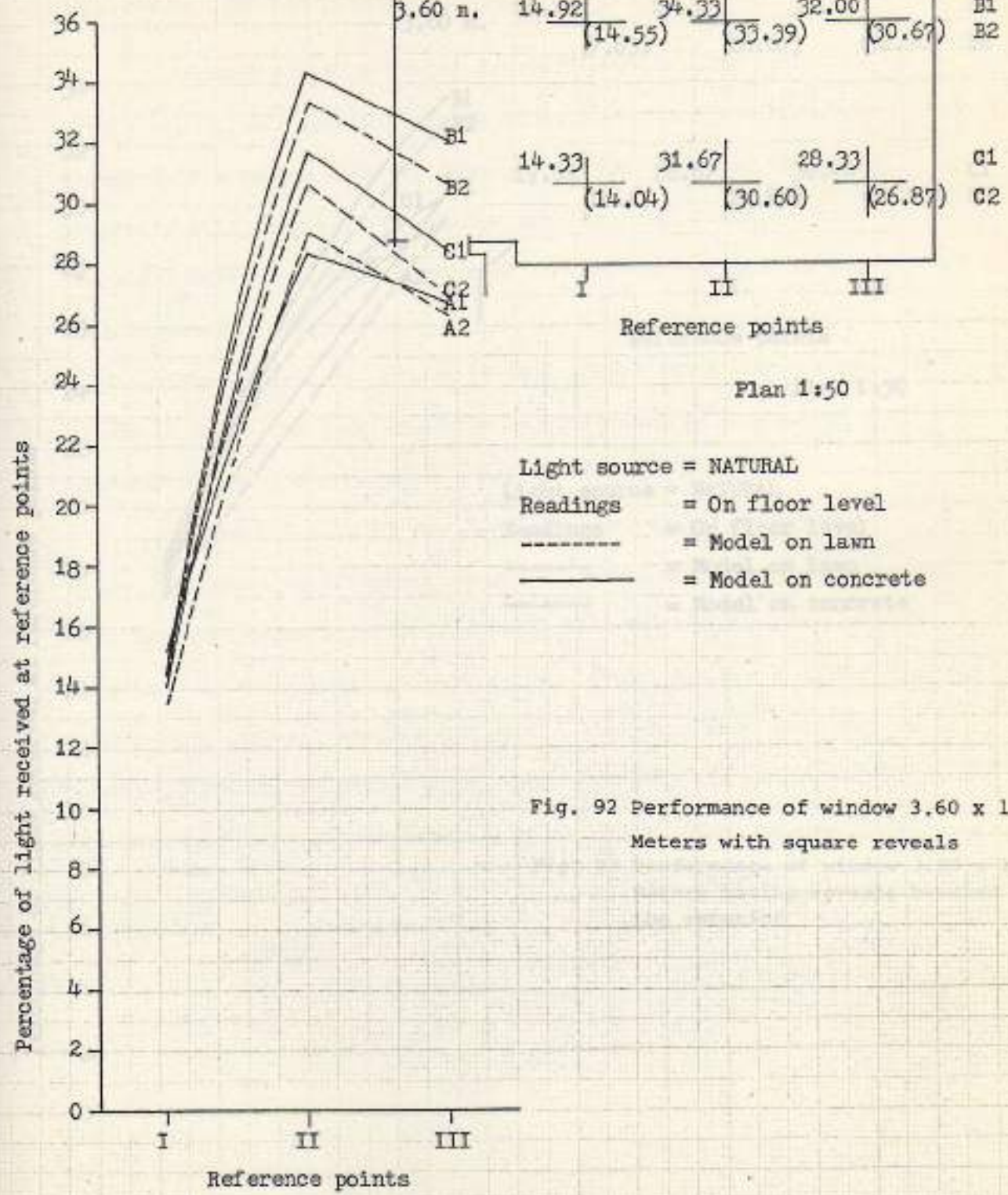

Fig. 92 Performance of window 3.60 x 1.30 Meters with square reveals

Room = 4.00 x 3.50 x 2.75 m.

Window = 3.60 x 1.30 m.

Sill = 0.90 m.

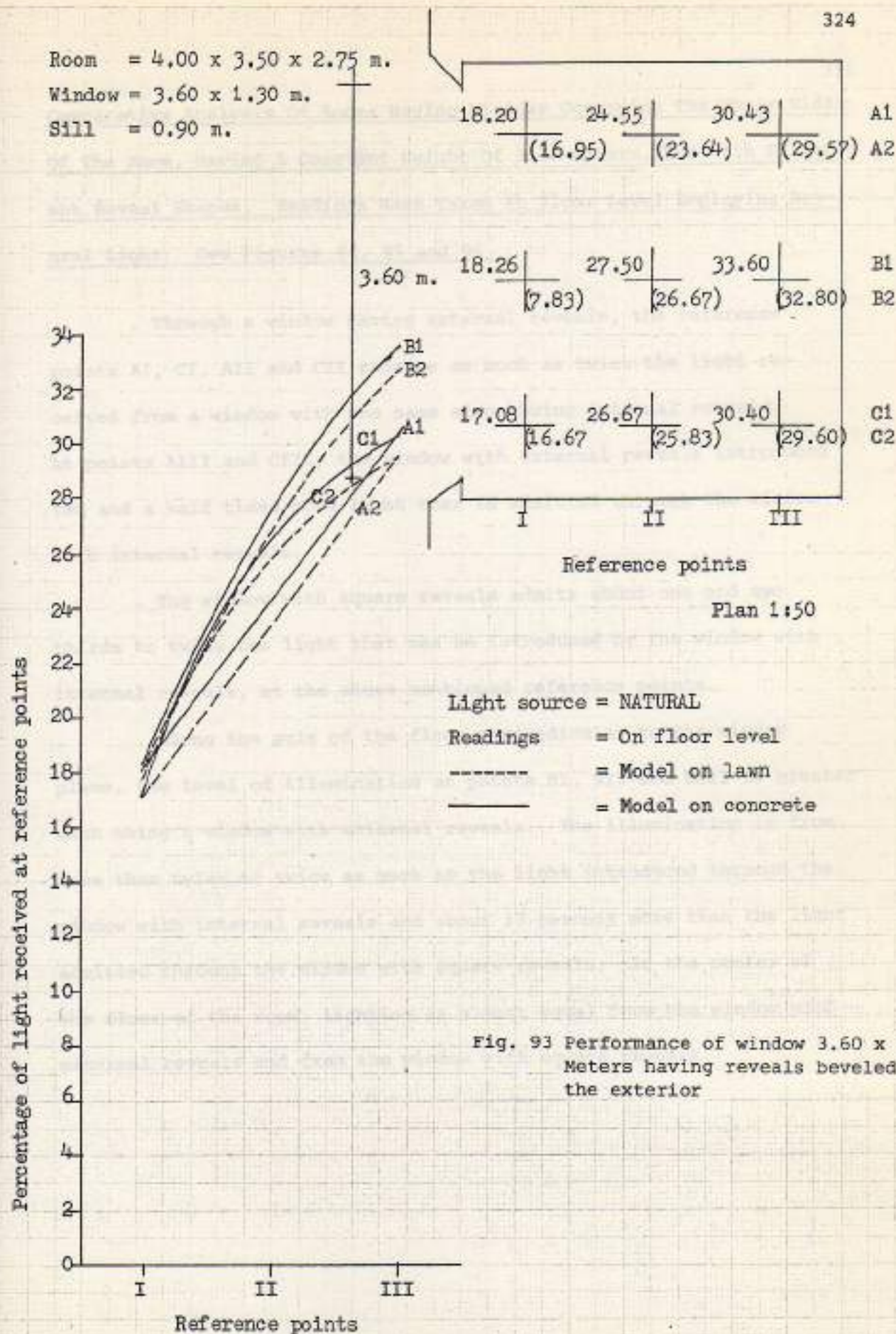

Fig. 93 Performance of window 3.60 x 1.30 Meters having reveals beveled to the exterior

Comparative Analysis Of Rooms Having Windows Occupying The Whole Width Of The Room, Having A Constant Height Of 1.30 Meters, But With Different Reveal Shapes. Readings Were Taken At Floor Level Employing Natural Light. See Figures 94, 95 and 96.

. Through a window having external reveals, the reference points AI, CI, AII and CII receive as much as twice the light received from a window with the same size having internal reveals. At points AIII and CIII, the window with external reveals introduced two and a half times more light than is admitted through the window with internal reveals.

. The window with square reveals admits about one and two thirds to twice the light that can be introduced by the window with internal reveals, at the above mentioned reference points.

. Along the axis of the floor perpendicular to the window plane, the level of illumination at points BI, BII and BIII is greater when using a window with external reveals. The illumination is from less than twice to twice as much as the light introduced through the window with internal reveals and about 13 percent more than the light admitted through the window with square reveals. At the center of the floor of the room, lighting is almost equal from the window with external reveals and from the window with square reveals.

Room = 4.00 x 3.50 x 2.76 m.

Window = 4.00 x 1.30 m.

Sill = 0.90 m.

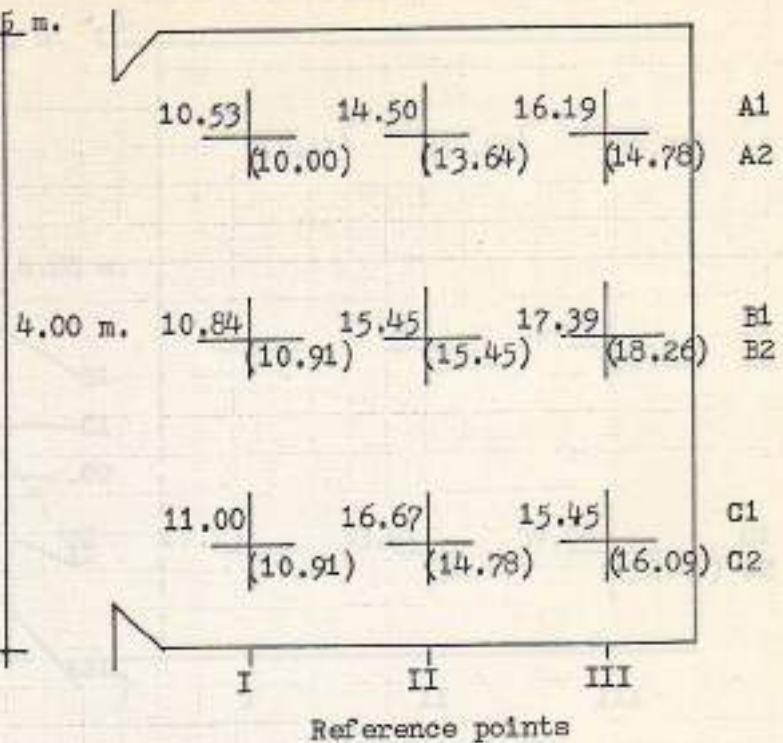

Plan 1:50

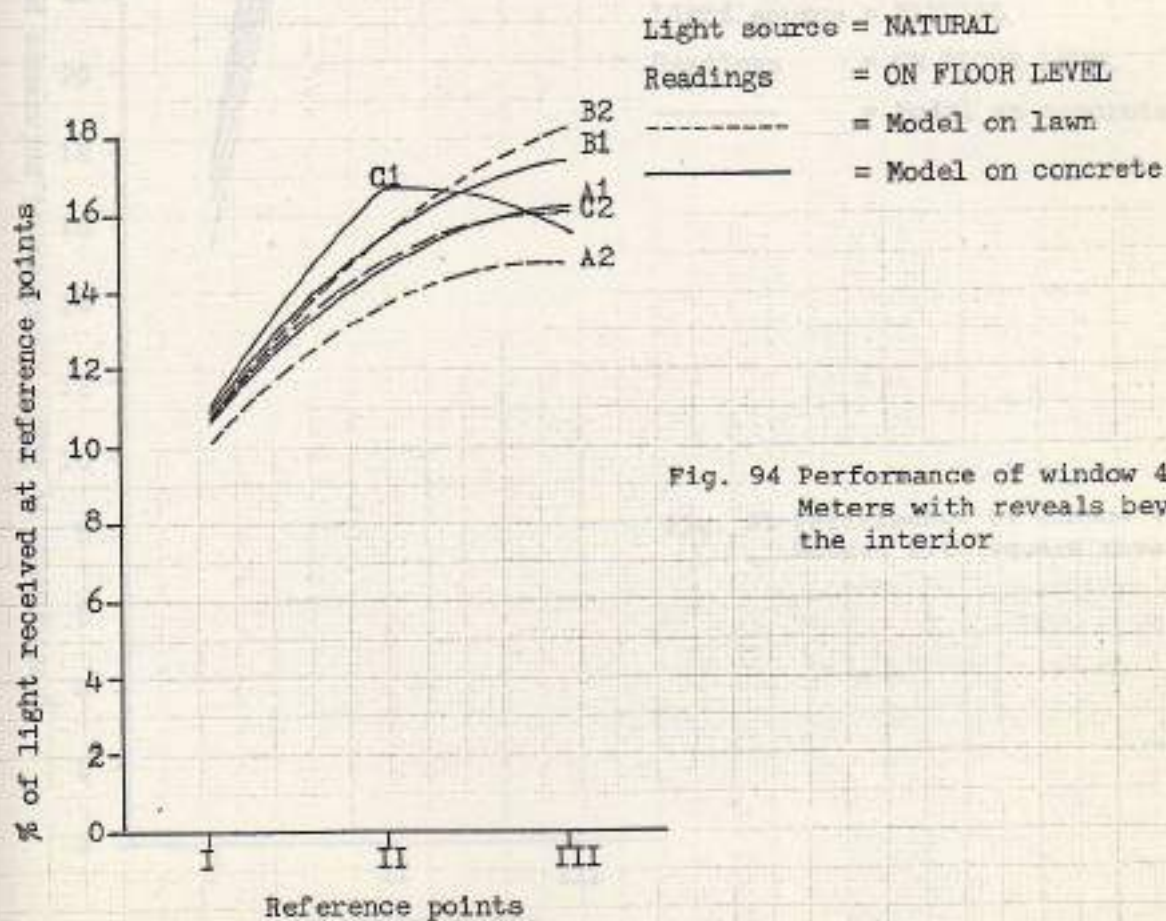

Fig. 94 Performance of window 4.00 x 1.30 Meters with reveals beveled to the interior

Room = 4.00 x 3.50 x 2.75 m.

Window = 4.00 x 1.30 m.

Sill = 0.90 m.

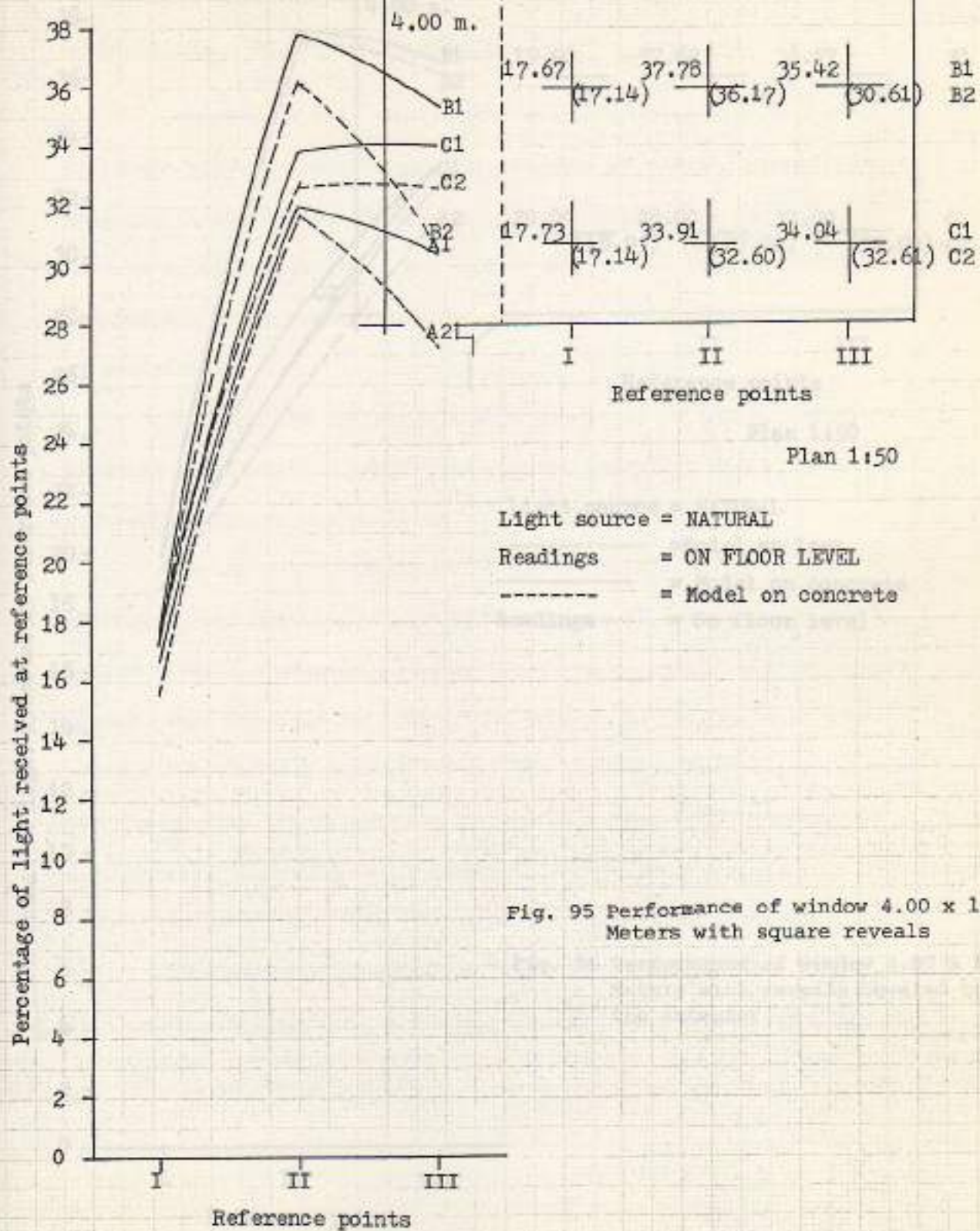
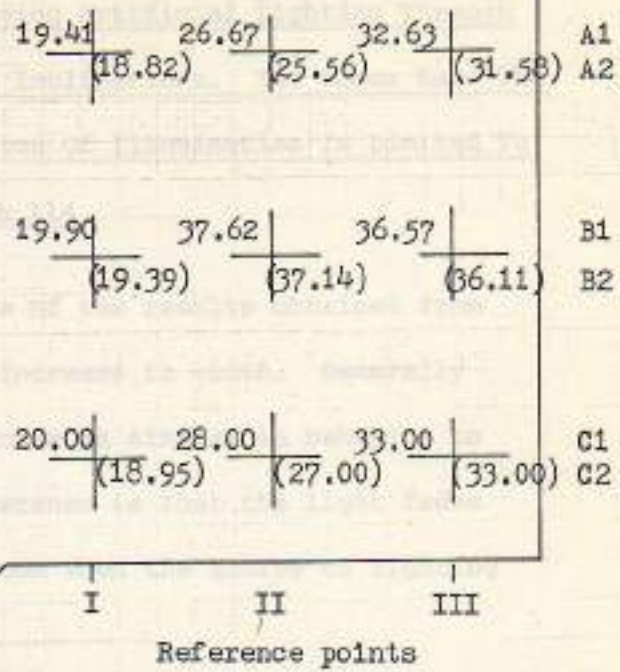
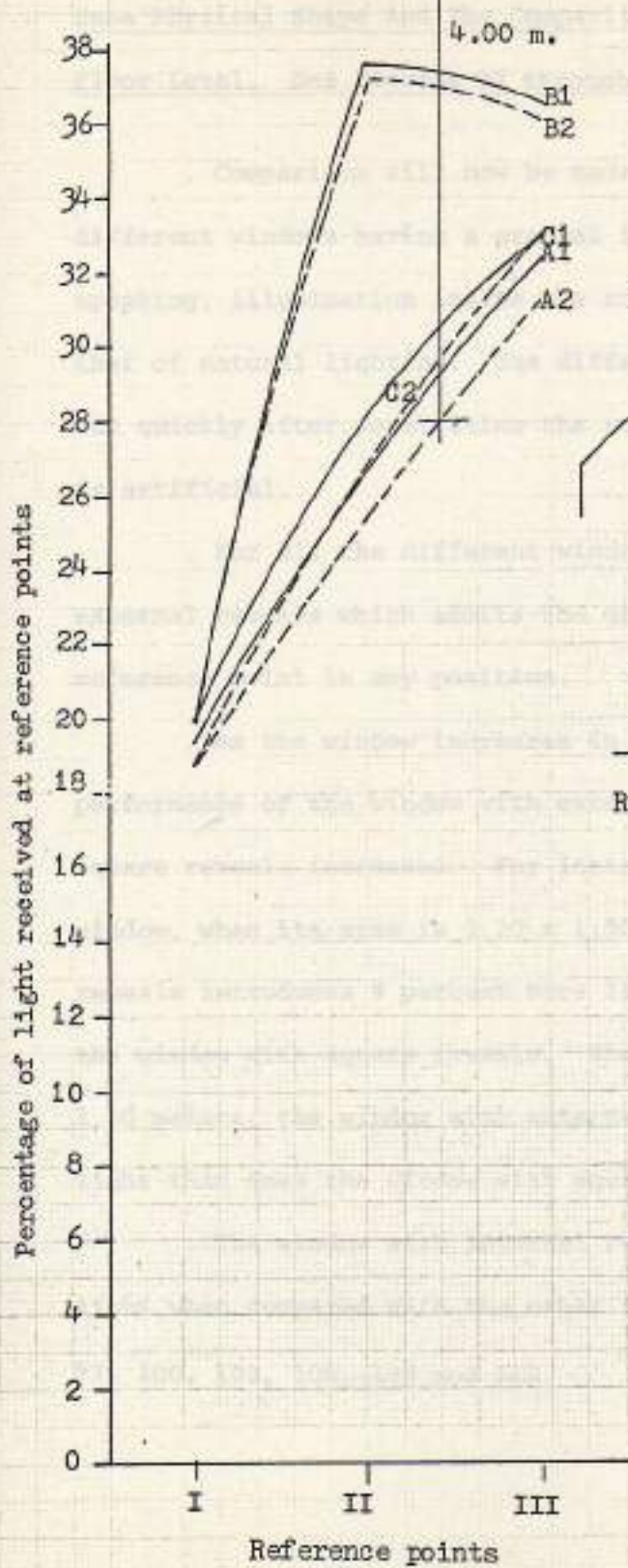

Fig. 95 Performance of window 4.00 x 1.30 Meters with square reveals

Room = 4.00 x 3.50 x 2.75 m.

Window = 4.00 x 1.30 m.

Sill = 0.90 m.



Plan 1:50

Light source = NATURAL
 ----- = Model on lawn
 _____ = Model on concrete
 Readings = On floor level

Fig. 96 Performance of window 4.00 x 1.30 Meters with reveals beveled to the exterior

Comparative Analysis Of Rooms Receiving Artificial Lighting Through Windows Which Have Different Reveal Inclinations. The Rooms Have The Same Physical Shape And The Comparison Of Illumination Is Limited To Floor Level. See Figures 97 through 114.

. Comparison will now be made of the results obtained from different windows having a gradual increase in width. Generally speaking, illumination inside the rooms is similar in behavior to that of natural lighting. The difference is that the light fades out quickly after penetrating the room when the source of lighting is artificial.

. For all the different window sizes, it is the window with external reveals which admits the greater amount of light to the reference point in any position.

. As the window increases in width the difference between the performance of the window with external reveals and the window with square reveals increases. For instance, at point BI in front of the window, when its size is 1.20 x 1.30 meters, the window with external reveals introduces 9 percent more light than that introduced through the window with square reveals. When the window size becomes 3.00 x 1.30 meters, the window with external reveals admits 22 percent more light than does the window with square reveals (see Figures 98 and 99).

. The window with internal reveals admits the least amount of light when compared with the other two types of windows (see Figures 97, 100, 103, 106, 109 and 112).

Room = 4.00 x 3.50 x 2.75 m.

Window = 1.20 x 1.30 m.

Sill = 0.90 m.

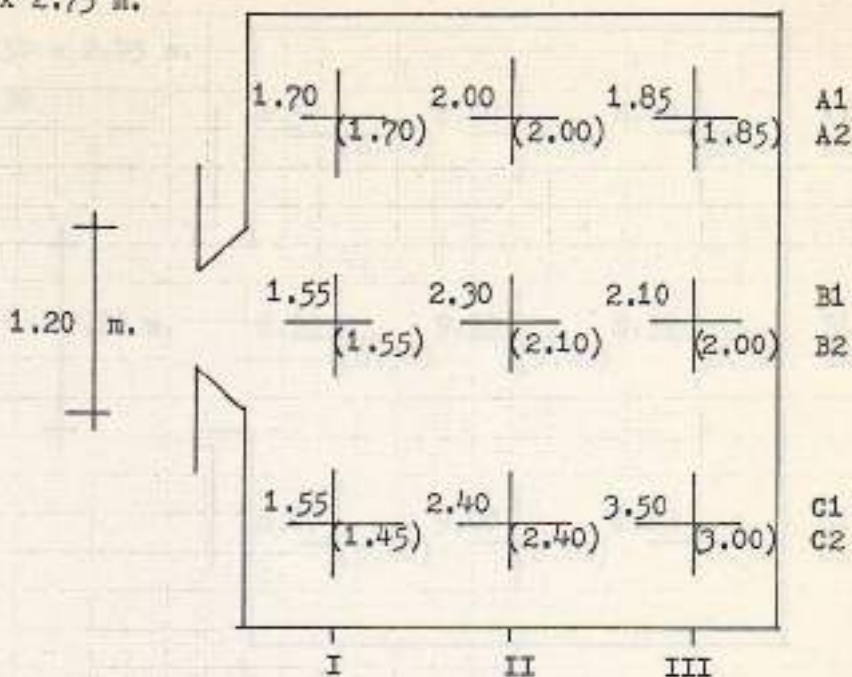

Reference points

Plan 1:50

Light source = ARTIFICIAL

Readings = On floor level

----- = Model on lawn

———— = Model on lawn

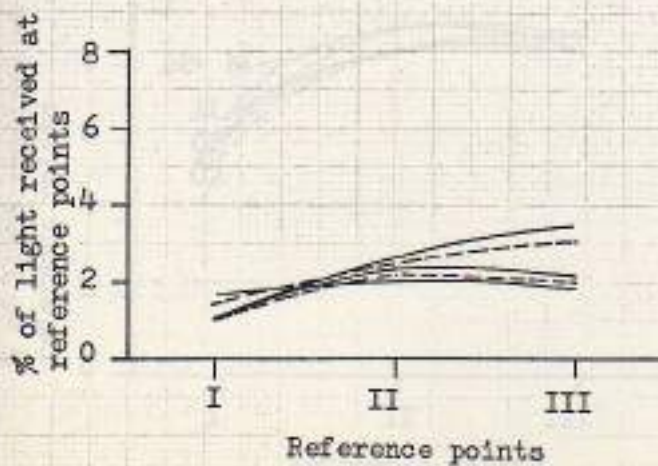
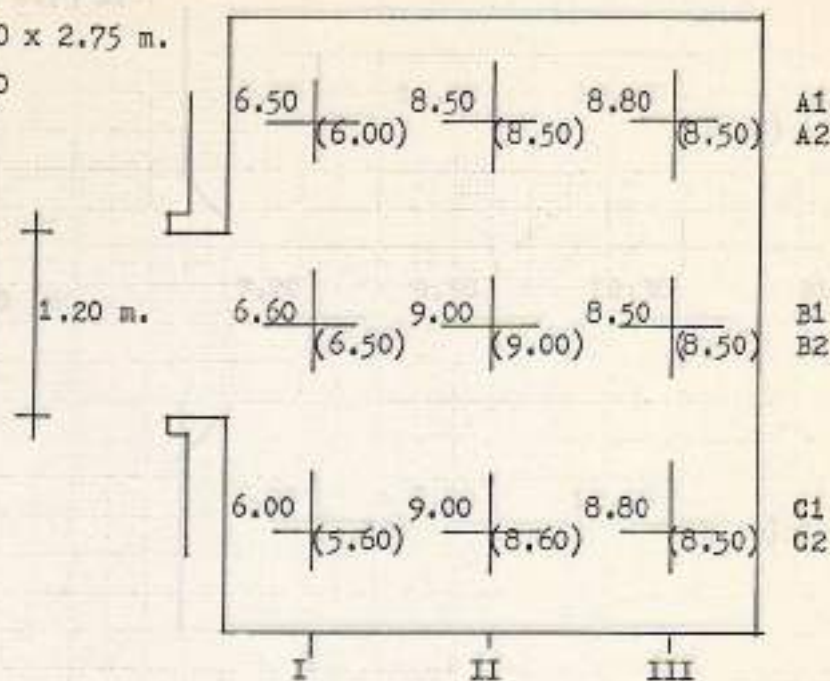

Fig. 97 Performance of window 1.20 x 1.30 Meters with reveals beveled to the interior

Room = 4.00 x 3.50 x 2.75 m.

Window = 1.20 x 1.30

Sill = 0.90 m.



Reference points

Plan 1:50

Light source = ARTIFICIAL

Readings = On floor level

----- = Model on lawn

————— = Model on concrete

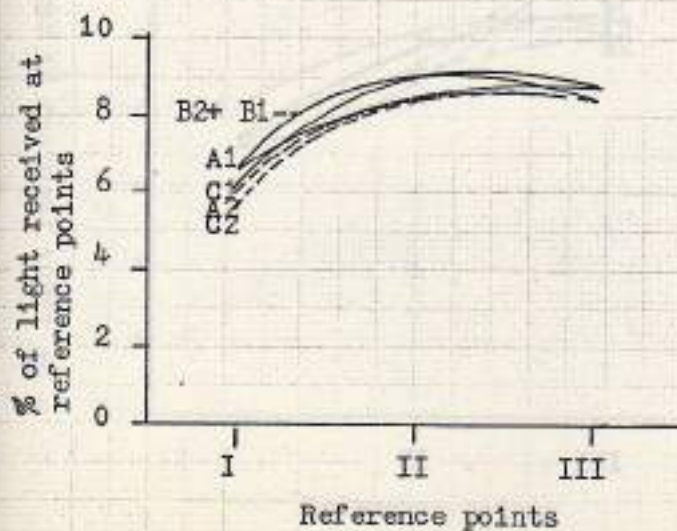
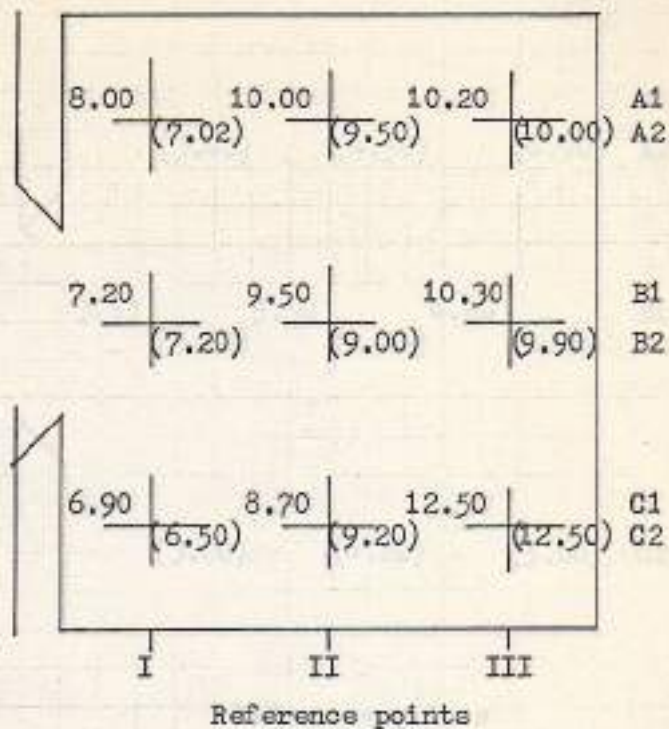
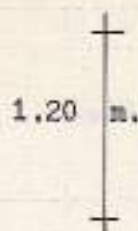

Fig. 98 Performance of window 1.20 x 1.30 Meters with square reveals

Room = 4,00 x 3,50 x 2,75 m.

Window = 1,20 x 1,30

Sill = 0,90 m.



Plan 1:50

Light source = ARTIFICIAL

Readings = On floor level

----- = Model on lawn

————— = Model on lawn

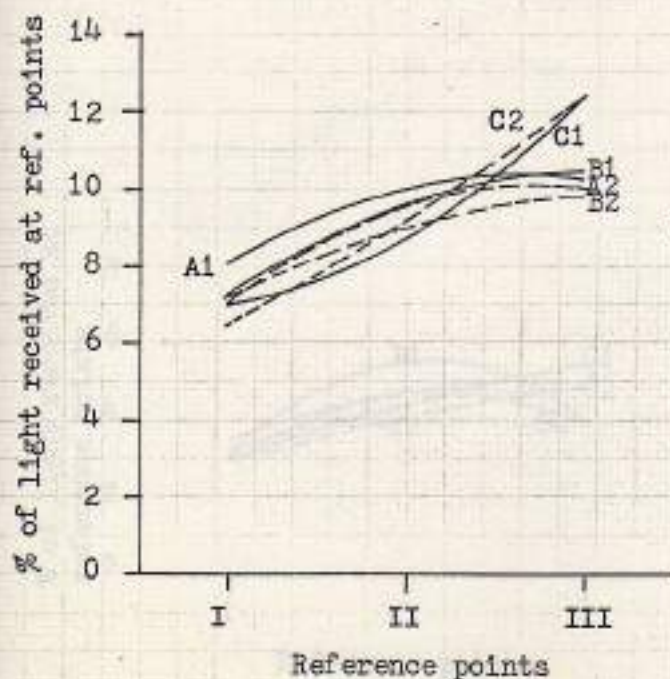
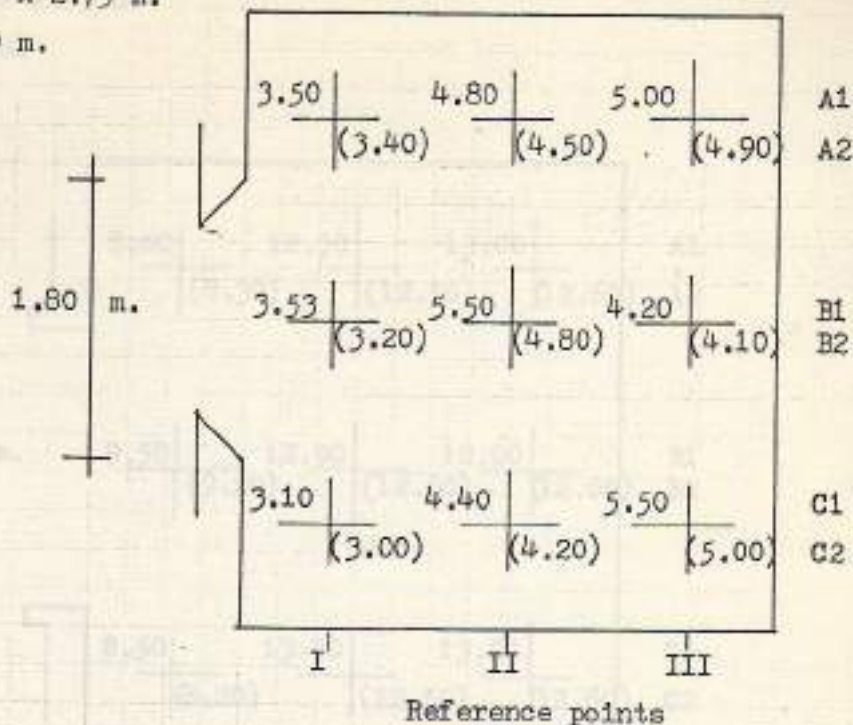

Fig. 99 Performance of window 1,20 x 1,30 Meters with reveals beveled to the exterior

Room = 4.00 x 3.50 x 2.75 m.

Window = 1.80 x 1.30 m.

Sill = 0.90 m.



Plan 1:50

Light source = ARTIFICIAL

Readings = On floor level

----- = Model on lawn

————— = Model on lawn

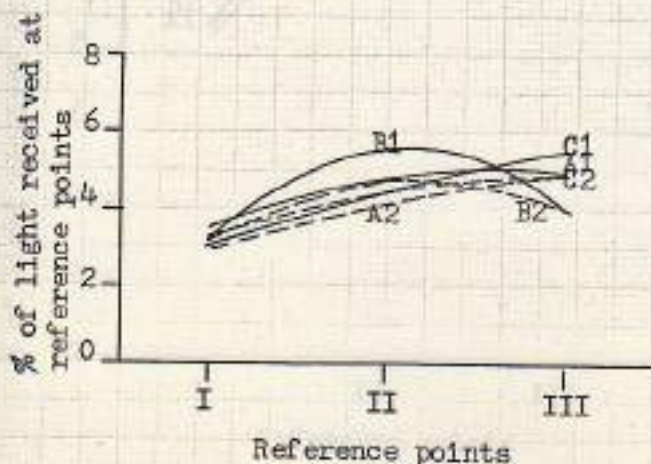
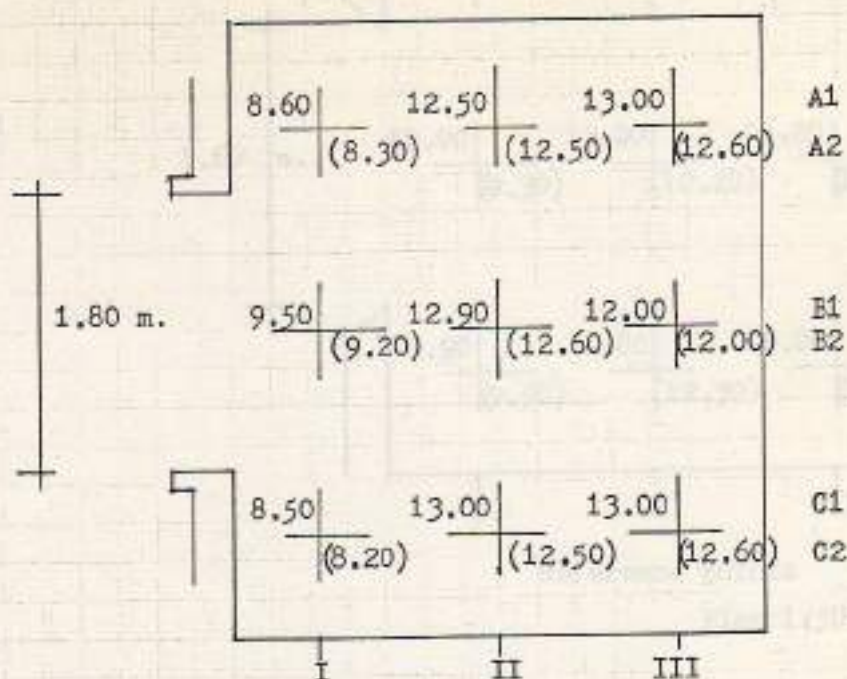

Fig. 100 Performance of window 1.80 x 1.30 Meters with reveals beveled to the interior

Room = 4.00 x 3.50 x 2.75 m.

Window = 1.80 x 1.30 m.

Sill = 0.90 m.



Reference points

Plan 1:50

Light source = ARTIFICIAL

Readings = on floor level

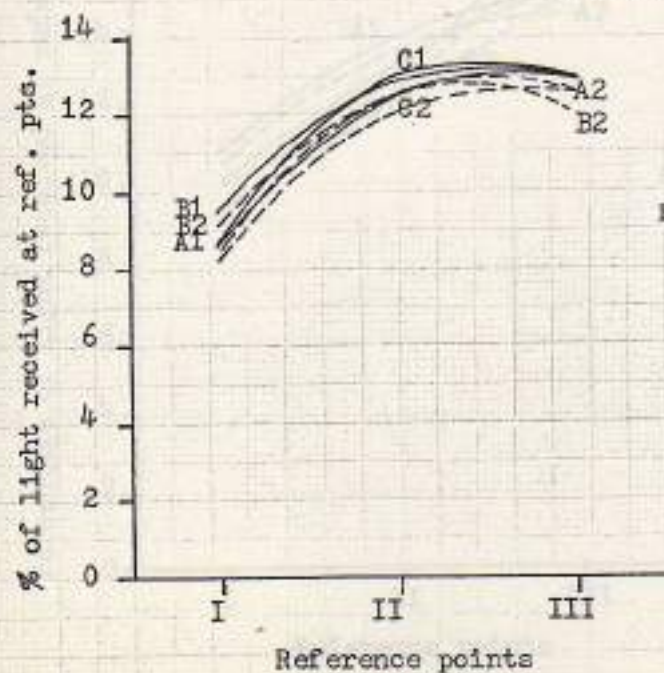

Fig. 101 Performance of window 1.80 x 1.30 Meters with square reveals

----- = Model on lawn

————— = Model on concrete

Room = 4.00 x 3.50 x 2.75 m.

Window = 1.80 x 1.30 m.

Sill = 0.90 m.

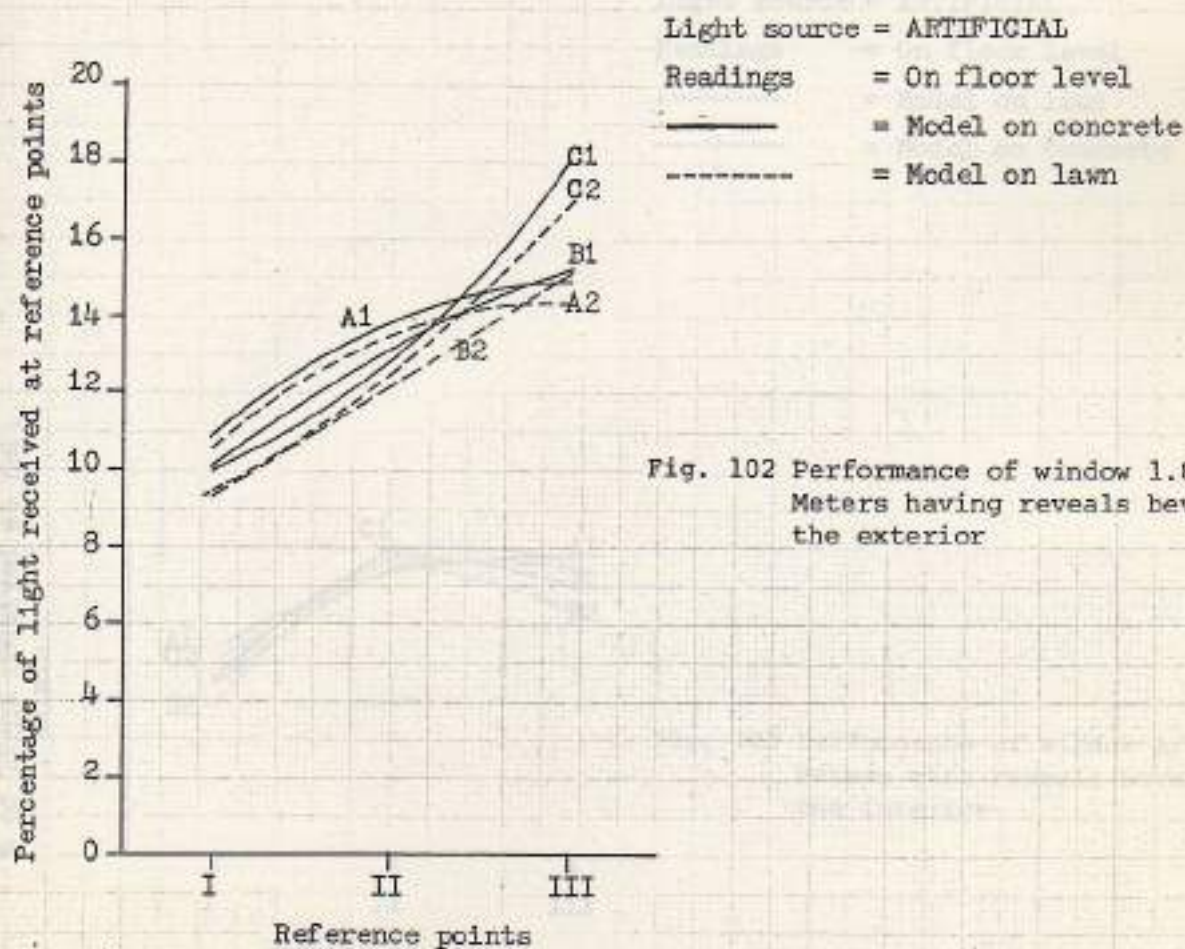
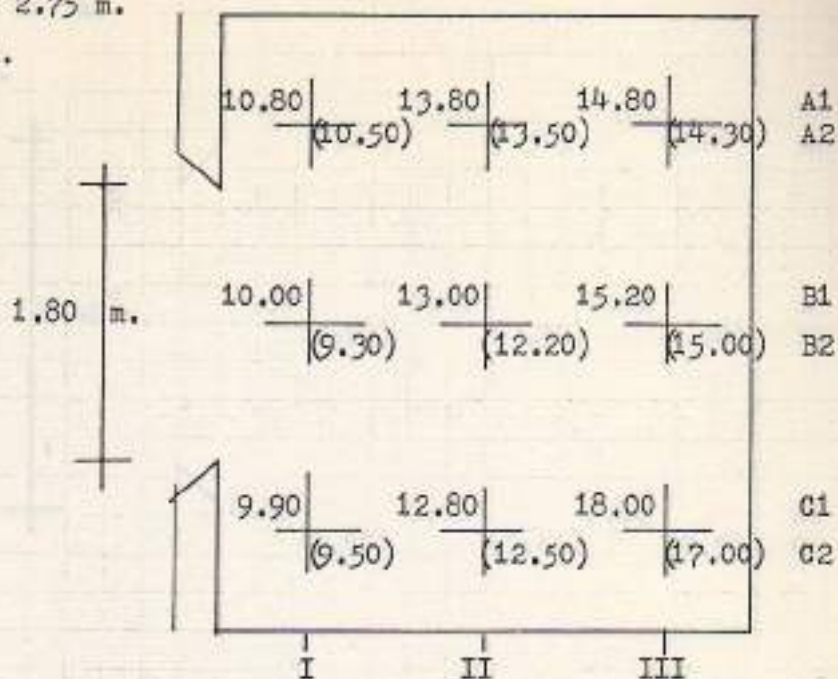
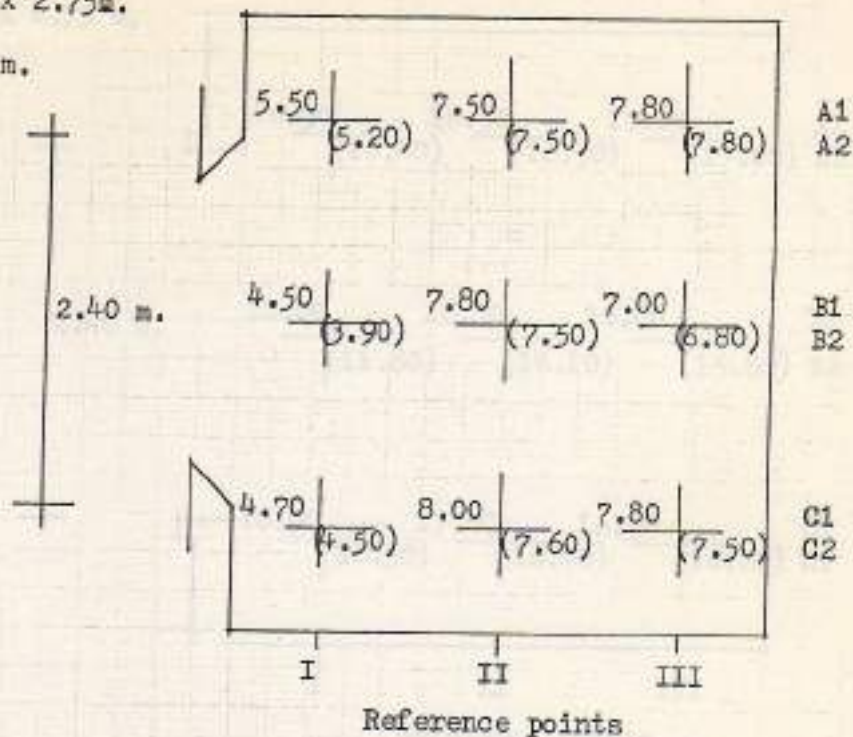

Fig. 102 Performance of window 1.80 x 1.30 Meters having reveals beveled to the exterior

Room = 4.00 x 3.50 x 2.75m.

Window = 2.40 x 1.30 m.

Sill = 0.90 m.



Plan 1:50

Light source = ARTIFICIAL

Readings = On floor level

----- = Model on lawn

————— = Model on concrete

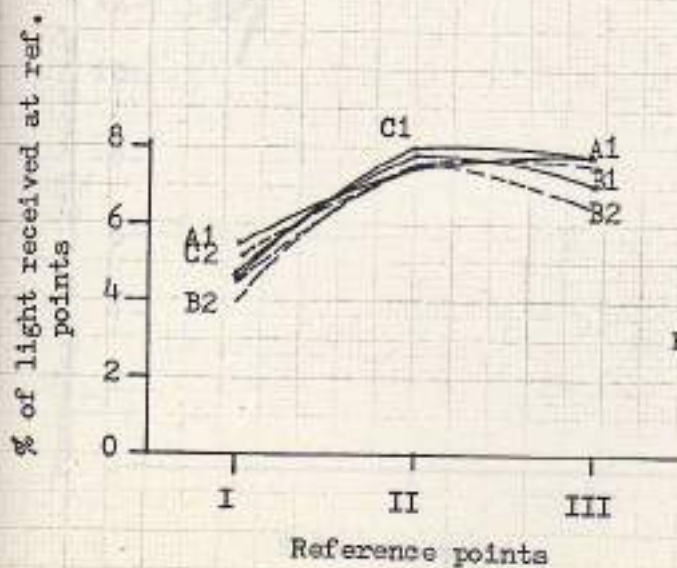

Fig. 103 Performance of window 2.40 x 1.30 Meters with reveals beveled to the interior

Room = 4.00 x 3.50 x 2.75 m.

Window = 2.40 x 1.30 m.

Sill = 0.90 m.

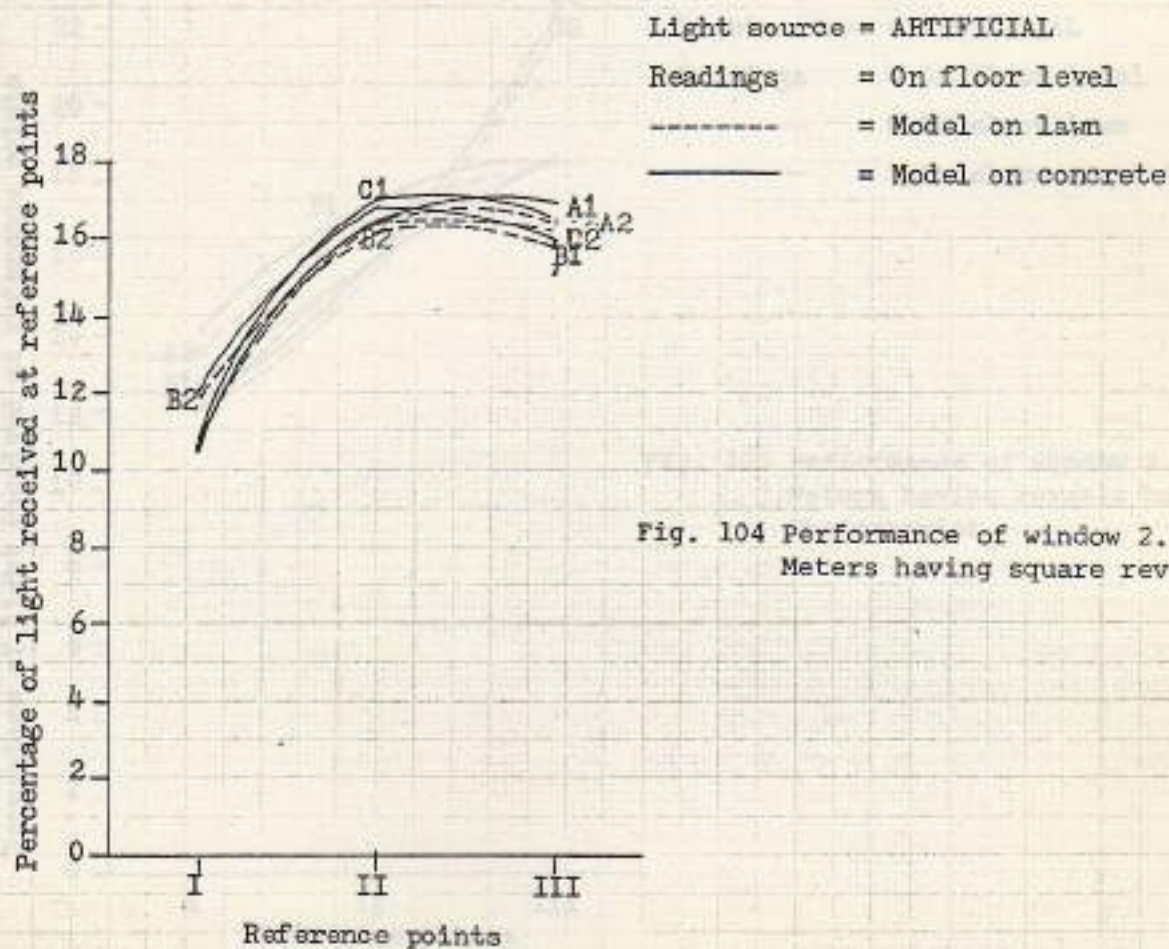
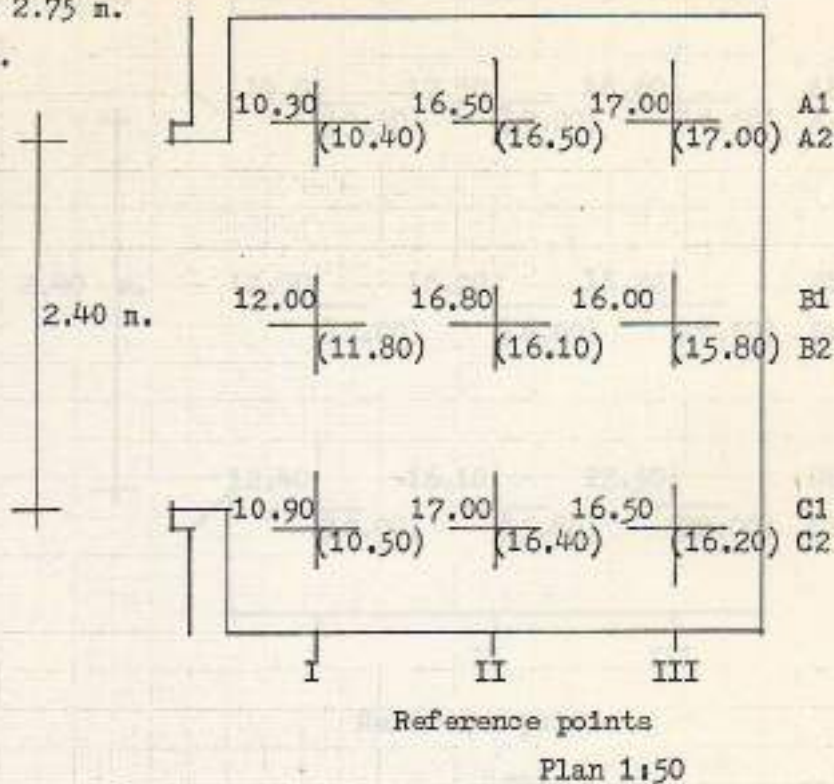
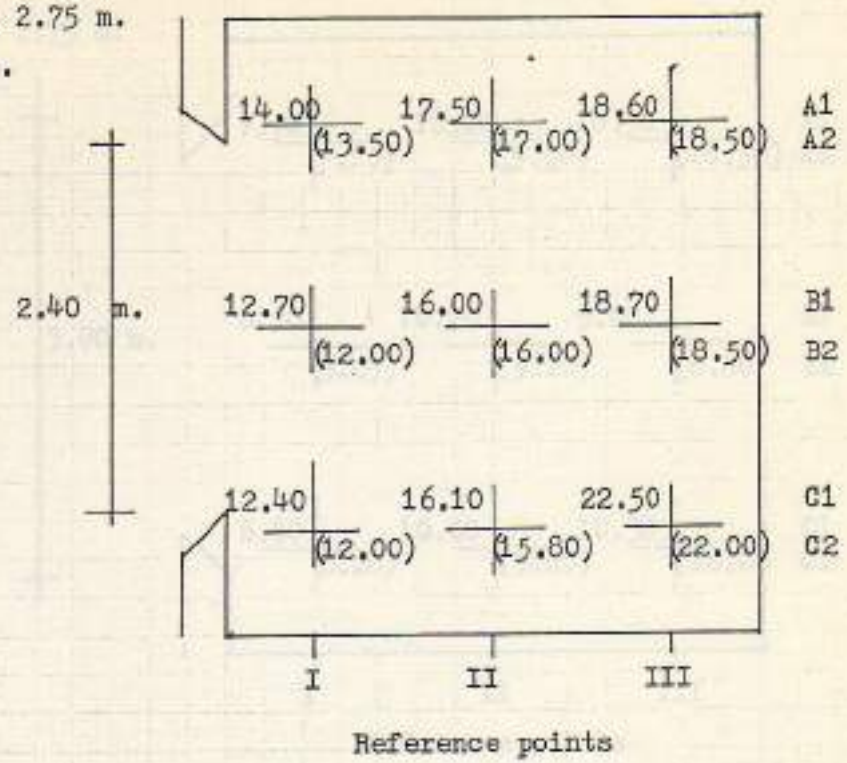

Fig. 104 Performance of window 2.40 x 1.30 Meters having square reveals

Room = 4.00 x 3.50 x 2.75 m.
 Window = 2.40 x 1.30 m.
 Sill = 0.90 m.



Reference points

Plan 1:50

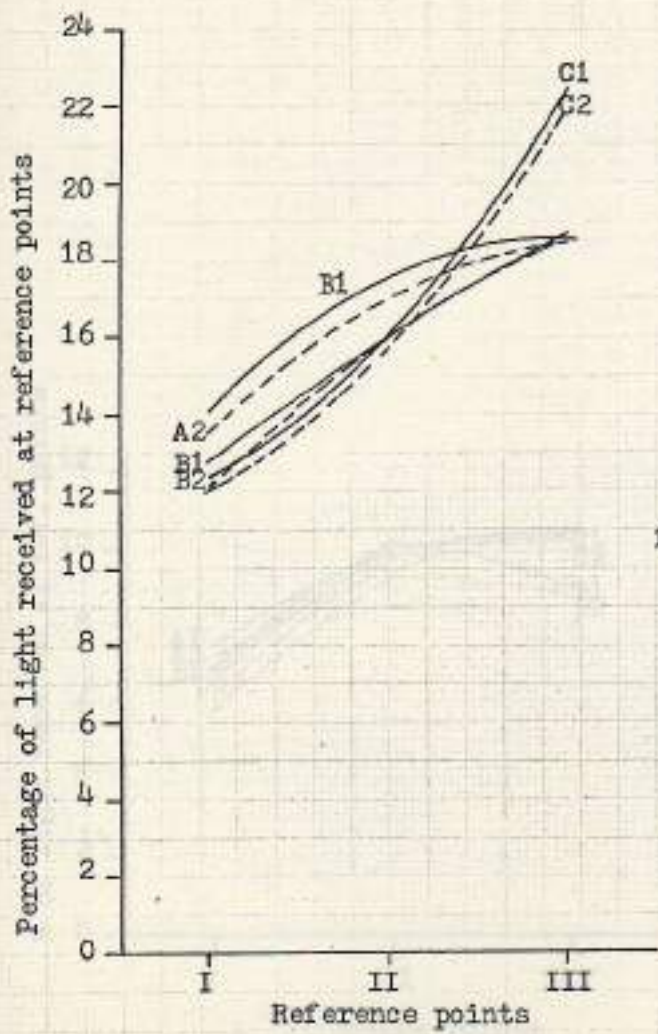

Light source = ARTIFICIAL
 Readings = On floor level
 ----- = Model on lawn
 _____ = Model on concrete

Fig. 105 Performance of window 2.40 x 1.30 Meters having reveals beveled to the exterior

Room = 4.00 x 3.50 x 2.75 m.

Window = 3.00 x 1.30 m.

Sill = 0.90 m.

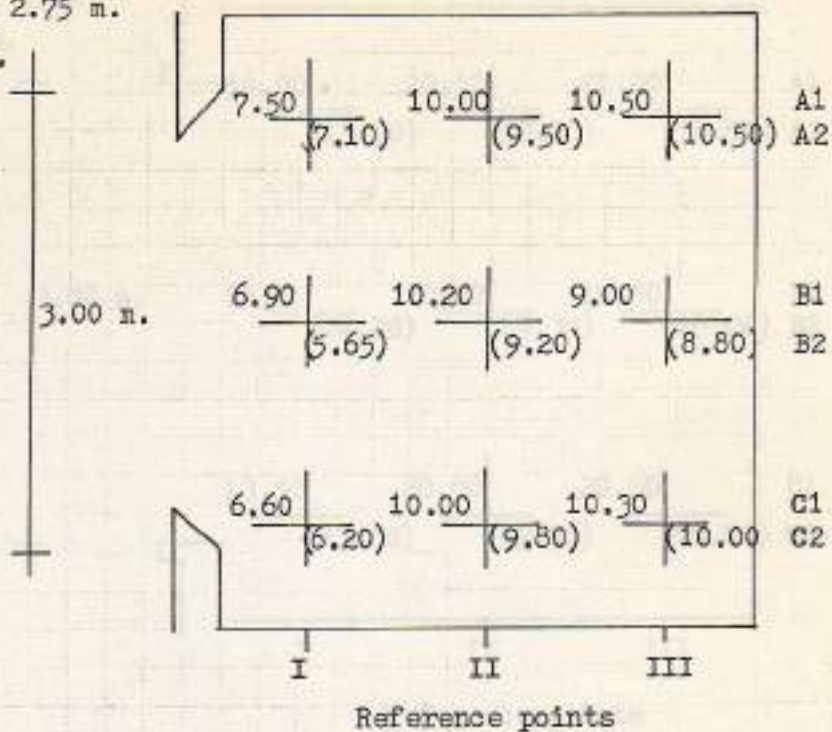

Plan 1:50

Light source = ARTIFICIAL

Readings = On floor level

----- = Model on lawn

————— = Model on concrete

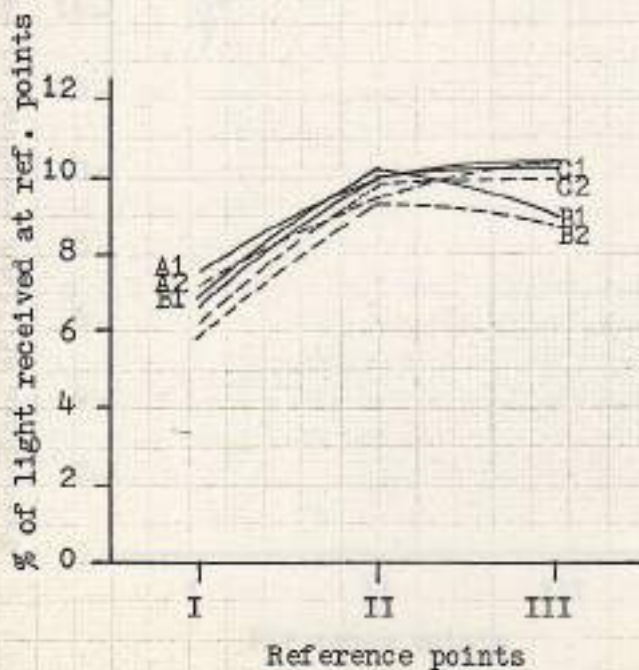
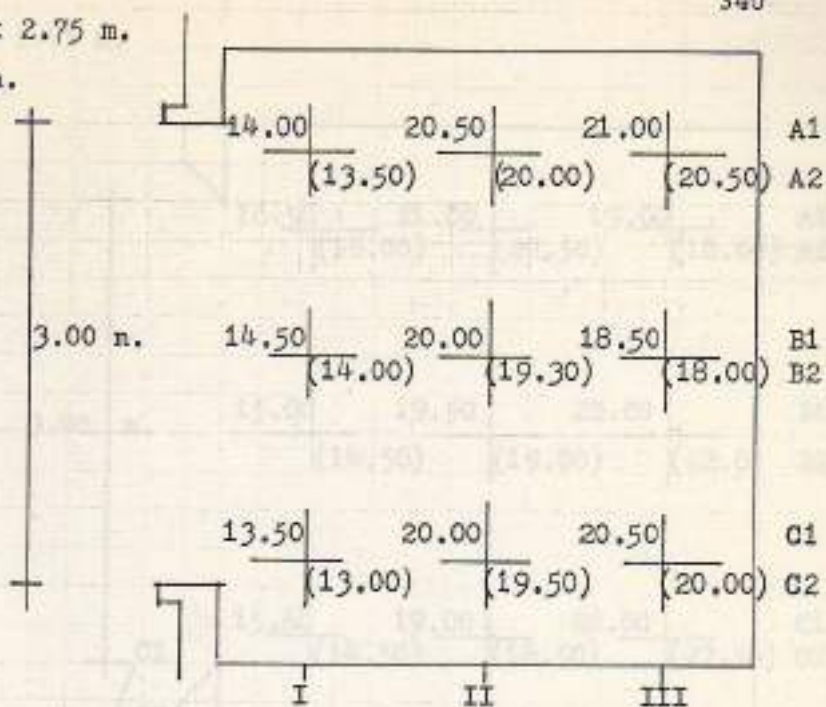

Fig. 106 Performance of window 3.00 x 1.30 Meters having reveals beveled to the interior

Room = 4.00 x 3.50 x 2.75 m.

Window = 3.00 x 1.30 m.

Sill = 0.90 m.



Reference points

Plan 1:50

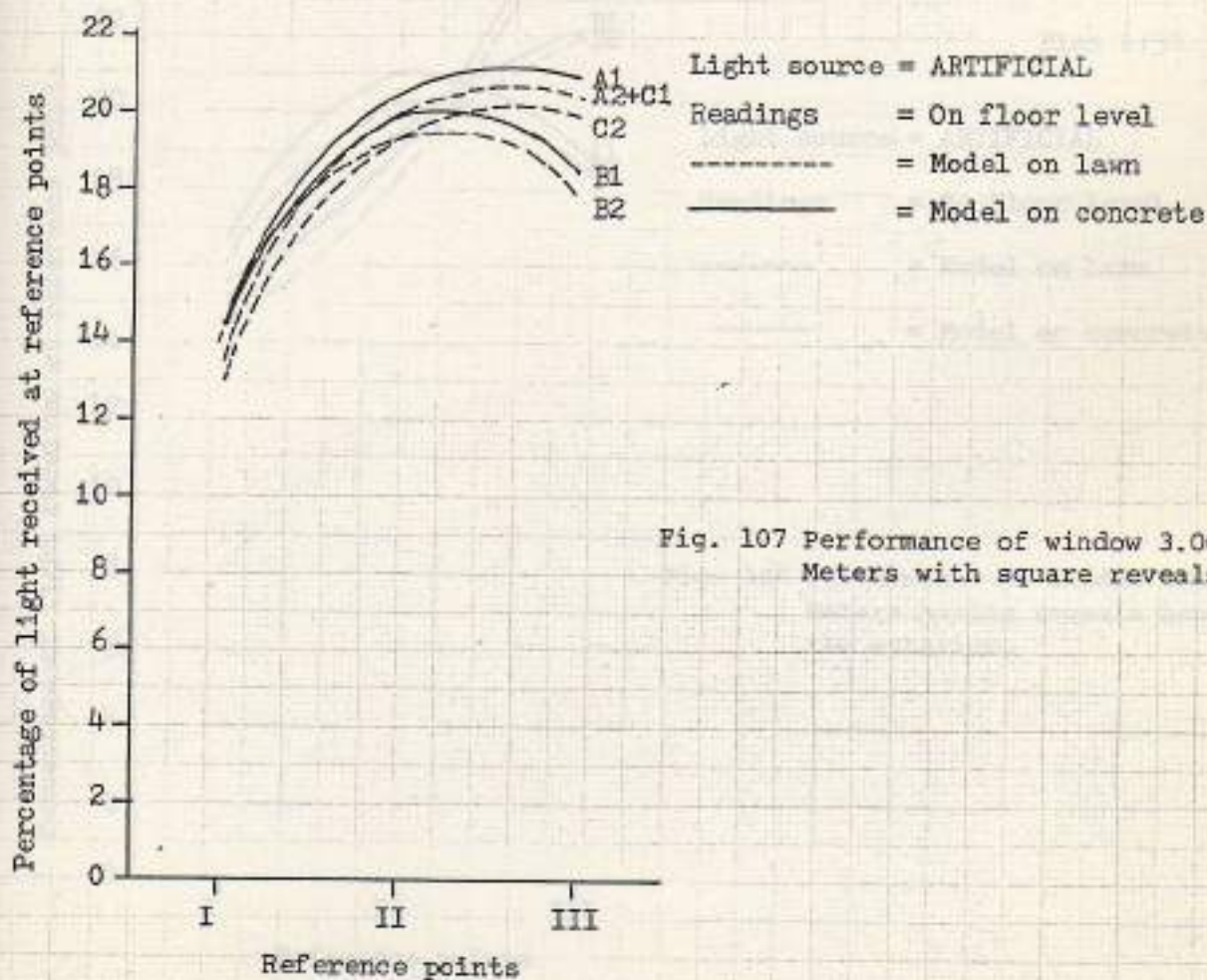

Fig. 107 Performance of window 3.00 x 1.30 Meters with square reveals

Room = 4.00 x 3.50 x 2.75 m.

Window = 3.00 x 1.30 m.

Sill = 0.90 m.

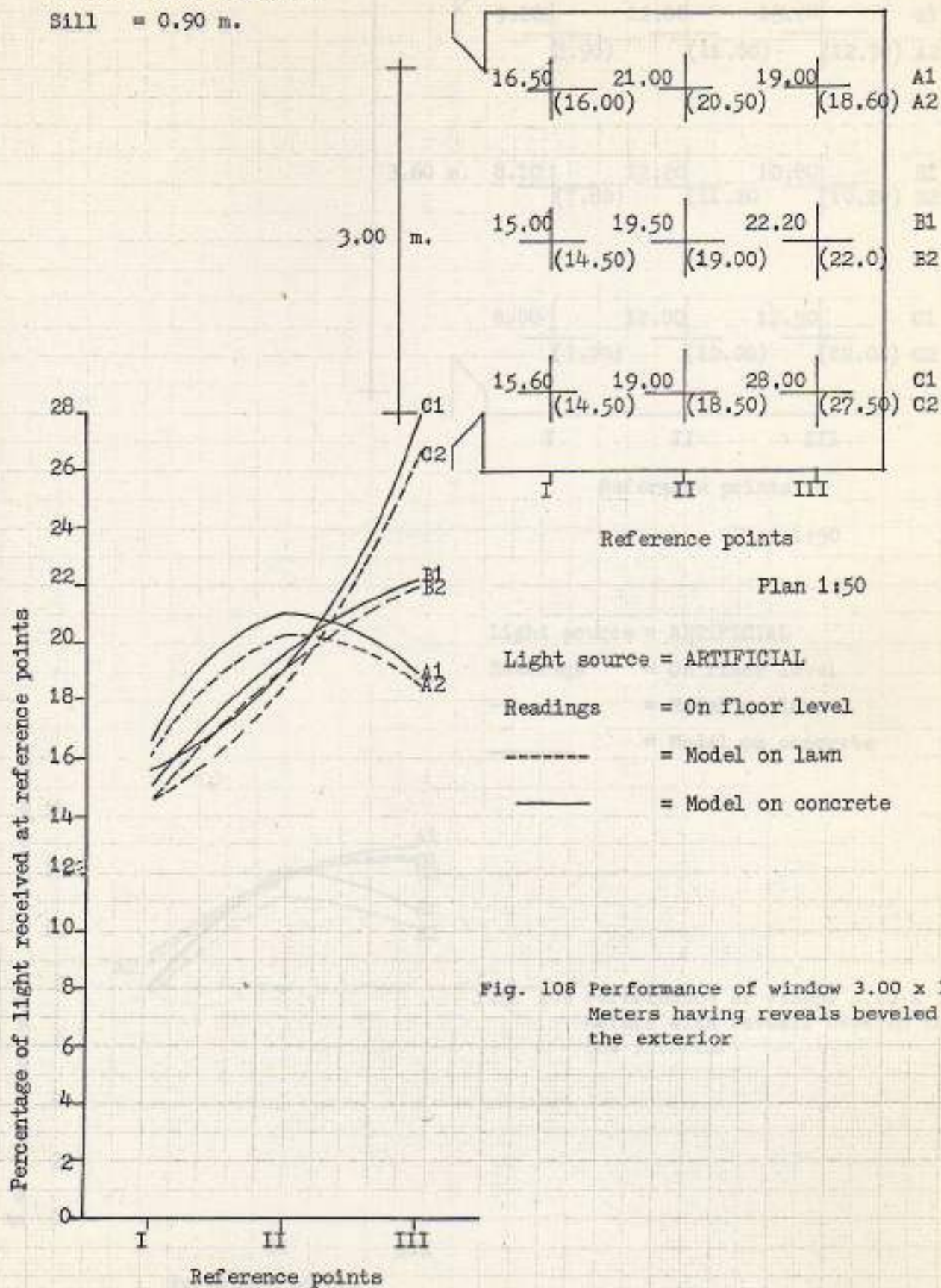
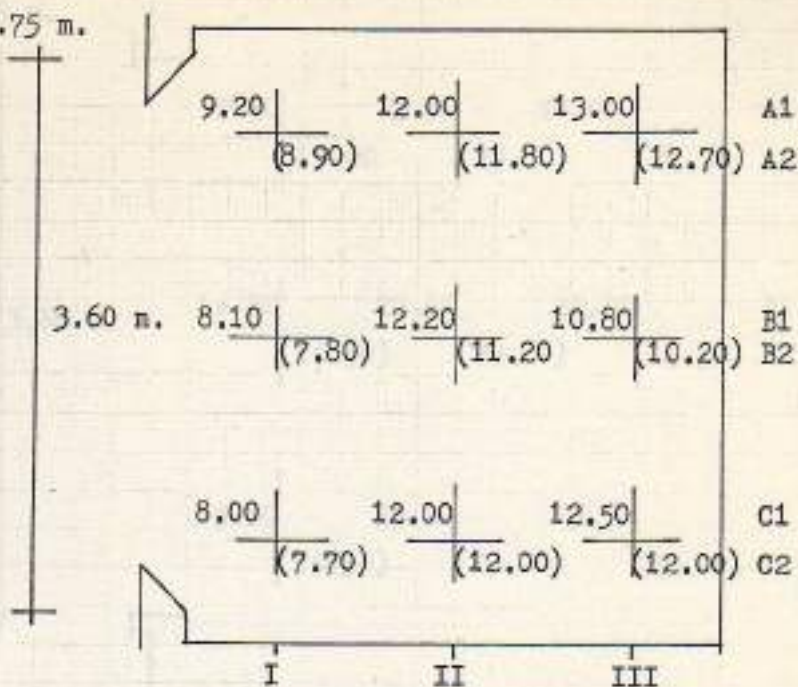

Fig. 108 Performance of window 3.00 x 1.30 Meters having reveals beveled to the exterior

Room = 4.00 x 3.50 x 2.75 m.

Window = 3.60 x 1.30 m.

Sill = 0.90 m.



Reference points

Plan 1:50

Light source = ARTIFICIAL

Readings = On floor level

----- = Model on lawn

————— = Model on concrete

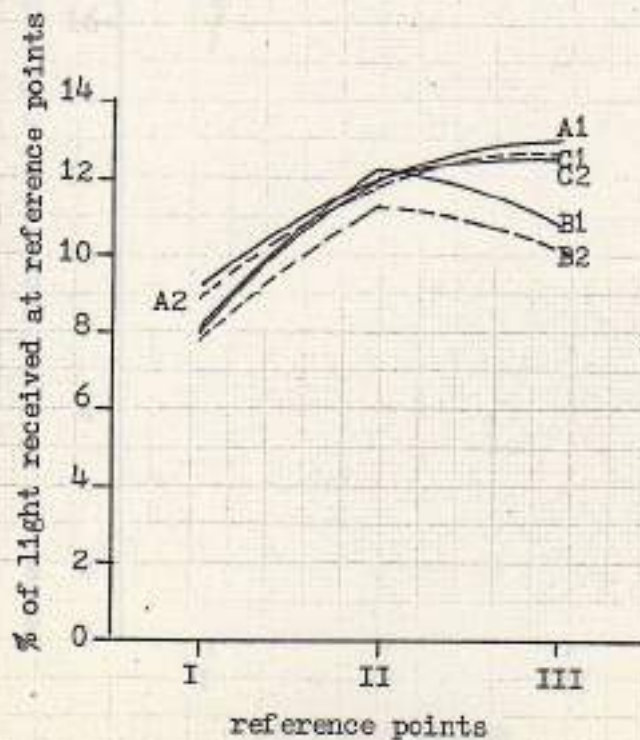
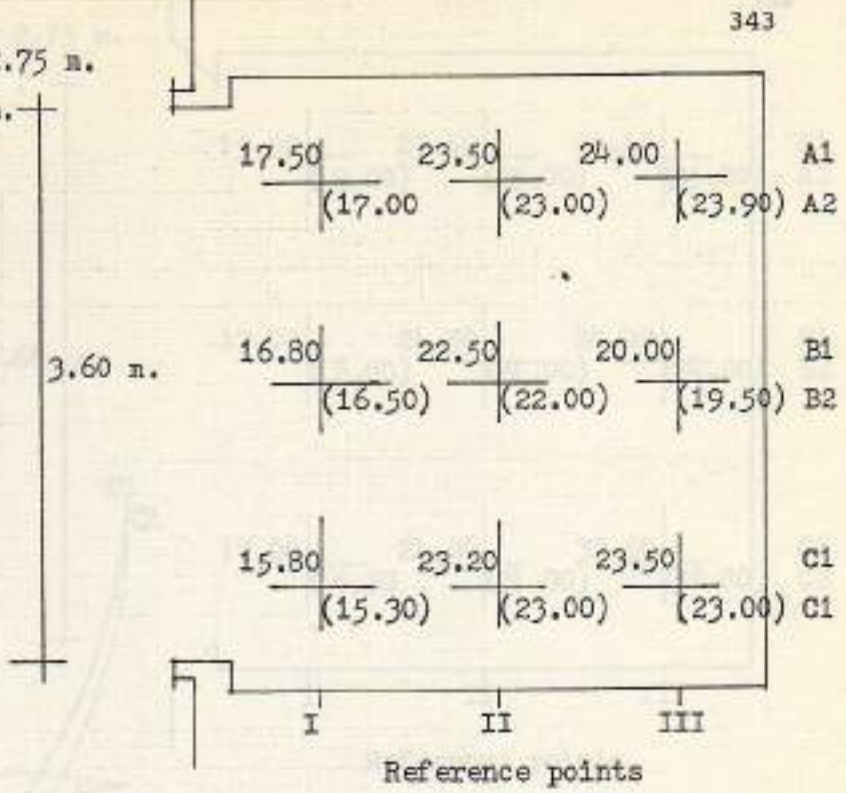

Fig. 109 Performance of window 3.60 x 1.30 Meters with reveals beveled to the interior

Room = 4.00 x 3.50 x 2.75 m.
 Window = 3.60 x 1.30 m.
 Sill = 0.90 m.



Reference points

Plan 1:50

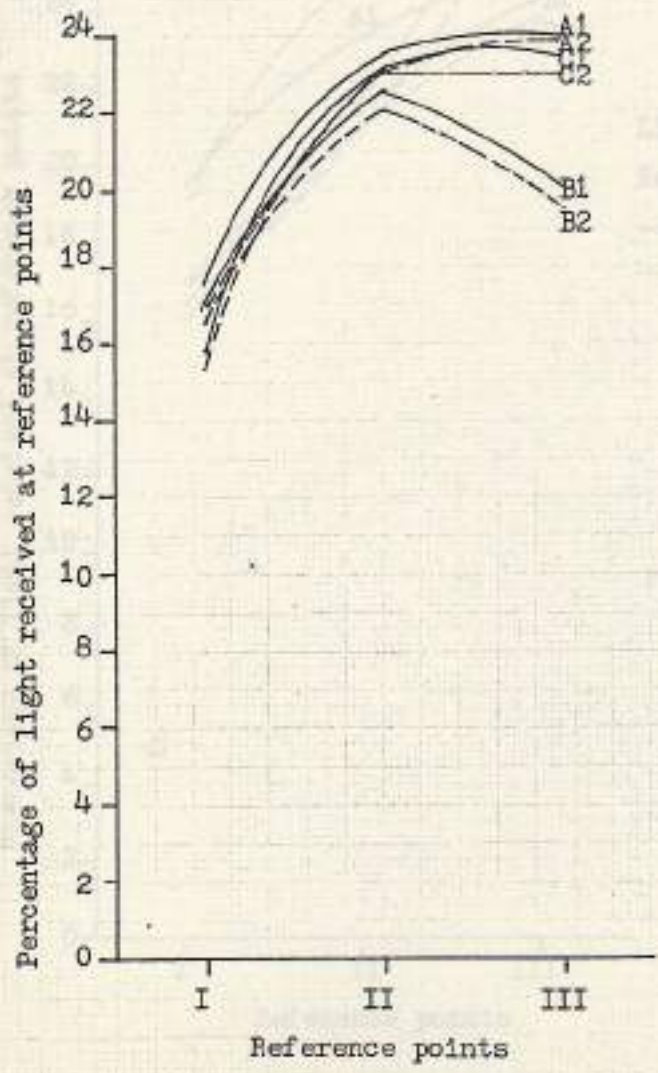

Light source = ARTIFICIAL
 Readings = On floor level
 ----- = Model on lawn
 _____ = Model on concrete

Fig. 110 Performance of window 3.60 x 1.30 Meters having square reveals

Room = 4.00 x 3.50 x 2.75 m.

Window = 3.60 x 1.30 m.

Sill = 0.90 m.

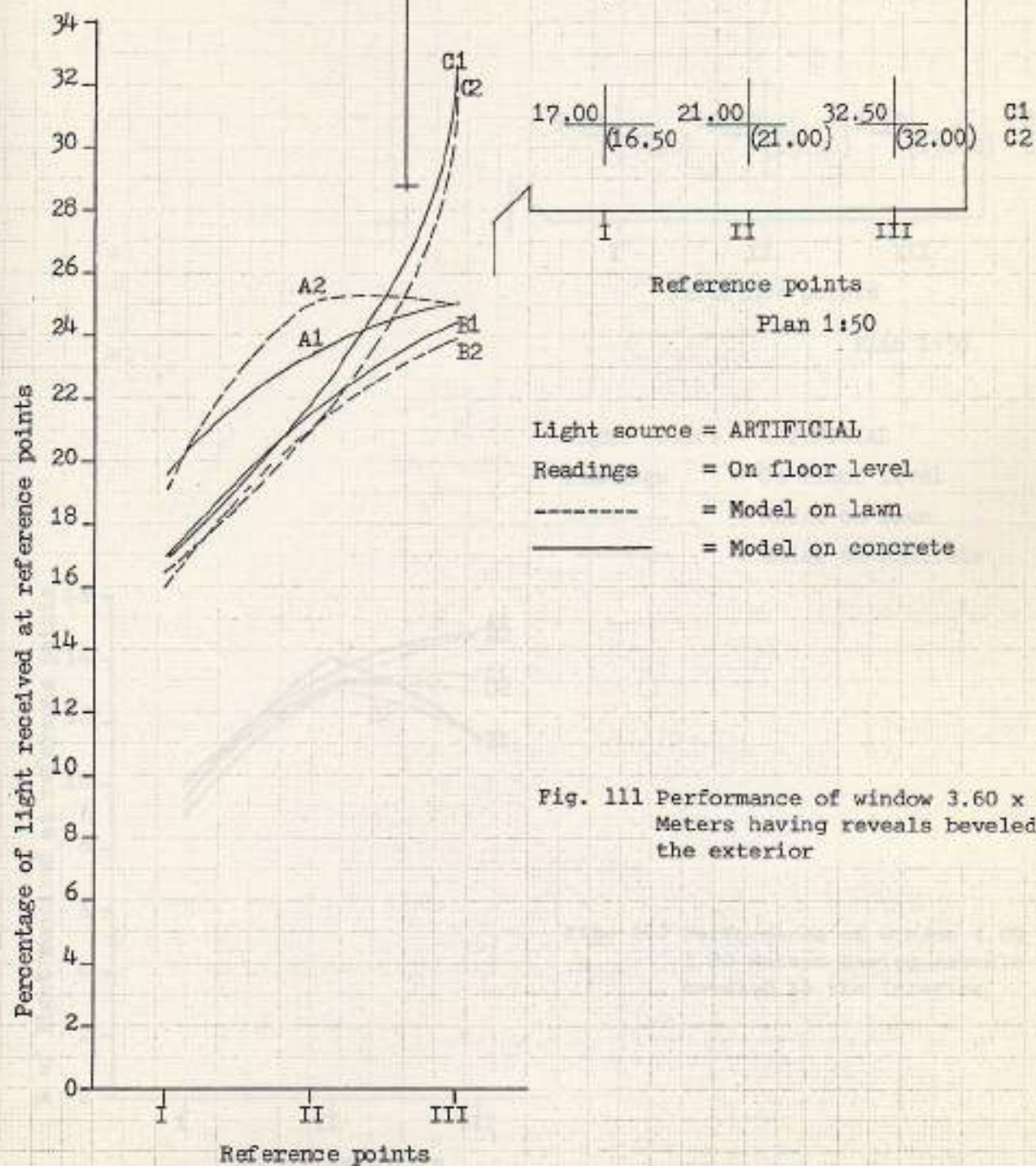

Fig. 111 Performance of window 3.60 x 1.30 Meters having reveals beveled to the exterior

Room = 4.00 x 3.50 x 2.25 m.

Window = 4.00 x 1.30 m.

Sill = 0.90 m.

4.00 m.

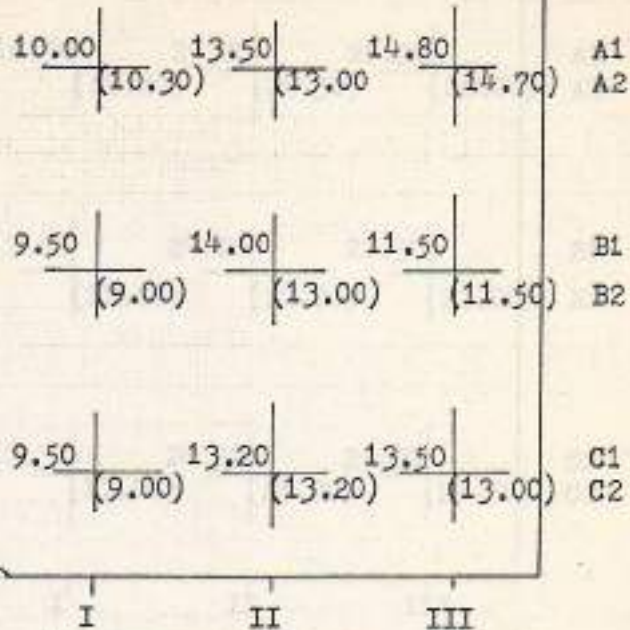

Reference points

Plan 1:50

Light source = ARTIFICIAL

Readings = On floor level

----- = Model on lawn

———— = Model on concrete

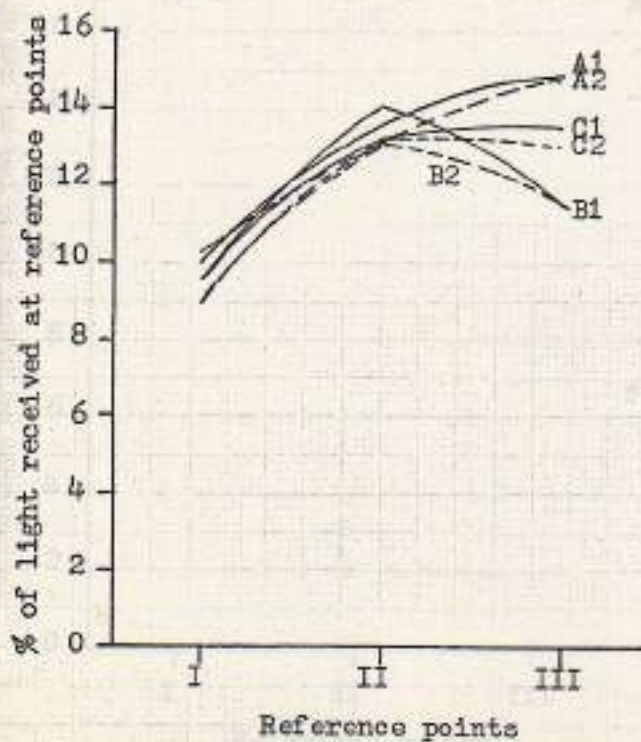

Fig. 112 Performance of window 4.00 x 1.30 Meters having reveals beveled to the interior

Room = 4.00 x 3.50 x 2.75 m.

Window = 4.00 x 1.30 m.

Sill = 0.90 m.

4.00 m.

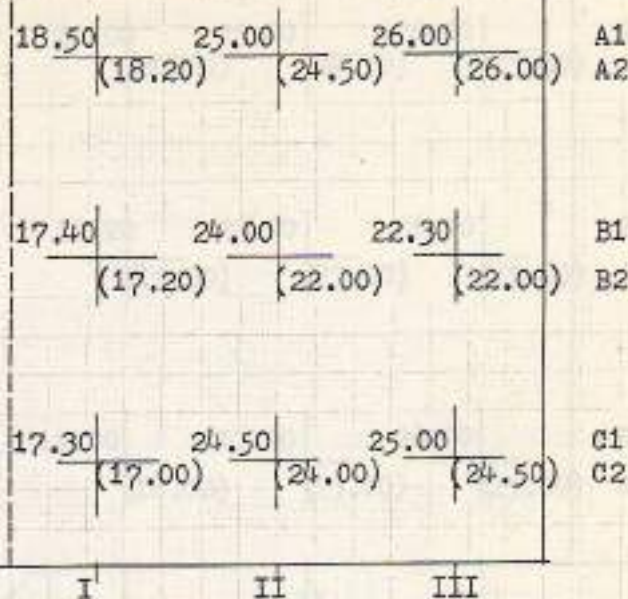

Reference points

Plan 1:50

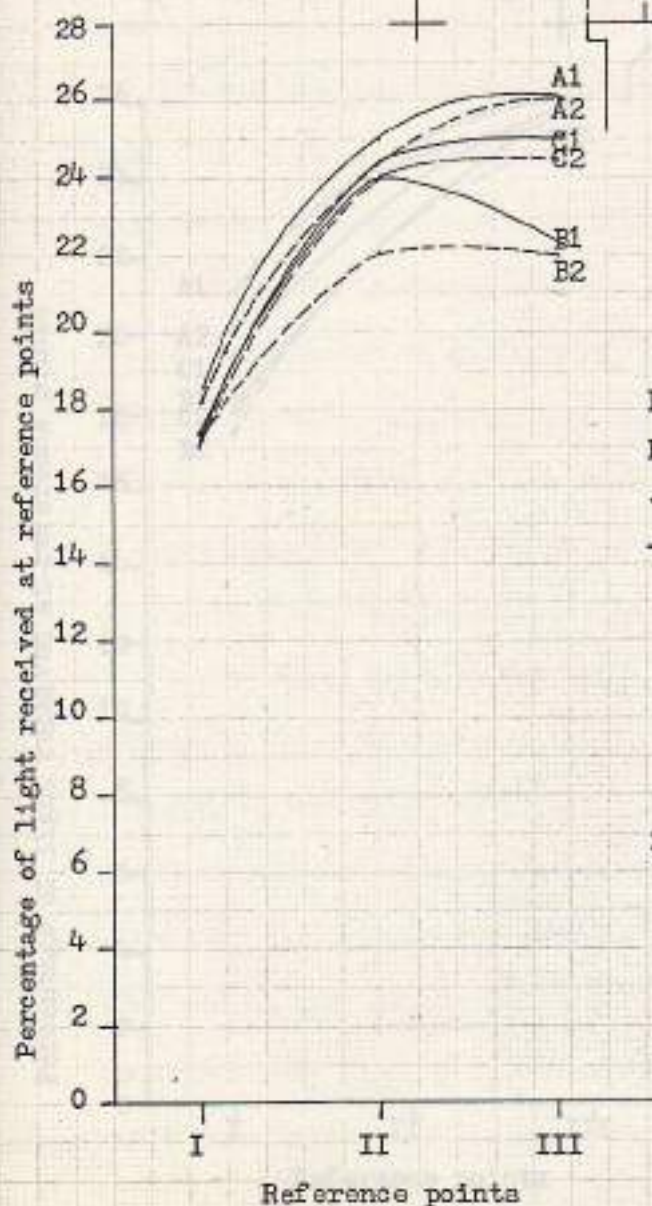

Light source = ARTIFICIAL

Readings = On floor level

----- = Model on lawn

————— = Model on concrete

Fig. 113 Performance of window 4.00 x 1.30 Meters having square reveals

Room = 4.00 x 3.50 2.75 m.
 Window = 4.00 x 1.30 m.
 Sill = 0.90 m.

4.00 m.

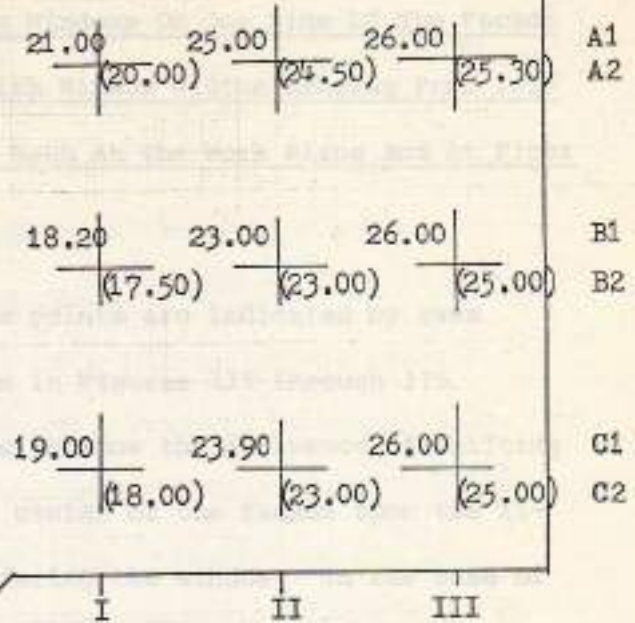

Reference points

Plan 1:50

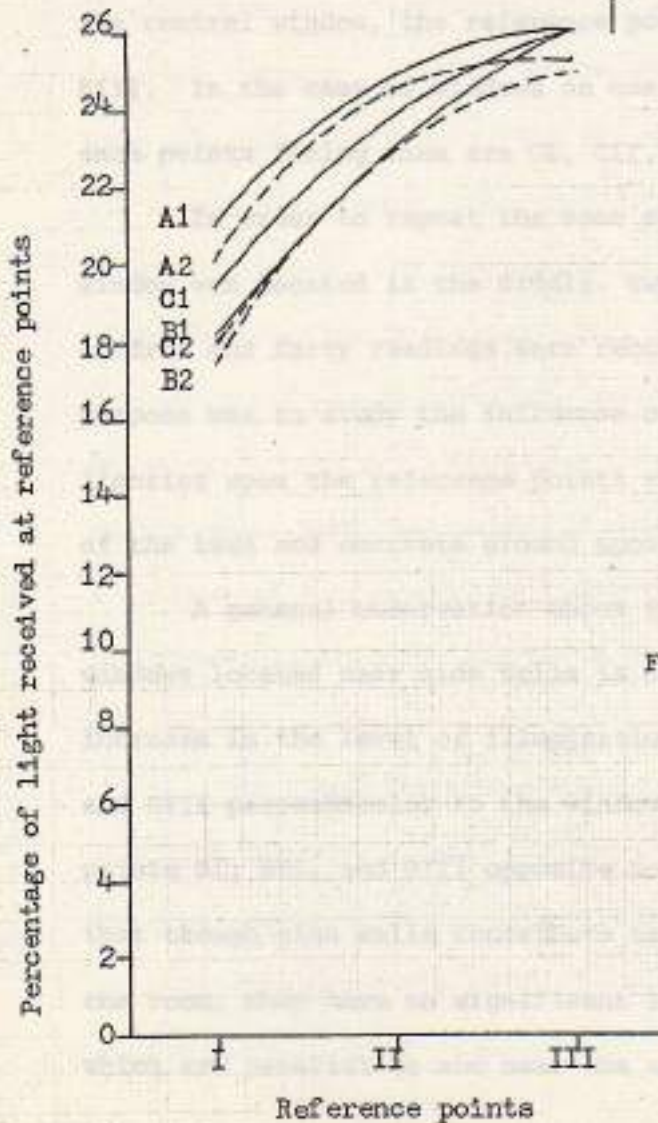

Light source = ARTIFICIAL
 Readings = On floor level
 ----- = Model on lawn
 _____ = Model on concrete

Fig. 114 Performance of window 4.00 x 1.30 Meters with reveals beveled to the exterior

Comparative Analysis Of Rooms Having Windows On One Side Of The Facade
But With Different Reveal Shapes, With Window Widths Ranging From 1.20
To 3.60 Meters. Readings Are Taken Both At The Work Plane And At Floor
Level.

The position of the reference points are indicated by axes A, B, C, and I, II, and III as shown in Figures 115 through 175.

The aim of this experiment is to know the influence of shifting the position of the window from the center of the facade upon the illumination at the reference points facing the window. In the case of the central window, the reference points facing them are BI, BII, and BIII. In the case of windows on one side of the facade, the reference points facing them are CI, CII, and CIII.

In order to repeat the same steps detailed previously when the window was located in the middle, twenty four experiments and two hundred and forty readings were recorded for each window size. The purpose was to study the influence of both natural and artificial lighting upon the reference points at different planes and the impact of the lawn and concrete ground upon the illumination at these points.

A general observation about the results obtained when using windows located near side walls is as follows. There is no significant increase in the level of illumination at the reference points CI, CII, and CIII perpendicular to the window when compared to the reference points BI, BII, and BIII opposite to the centered windows. This means that though side walls contribute to the general illumination inside the room, they have no significant impact upon the reference points which are parallel to and near the side walls.

. The window with internal reveals is the least efficient in illuminating the room when compared to the other types of reveal shapes.

. In general, except at the points adjacent to the windows, the windows with external reveals introduced a greater amount of light at the reference points than did the window having square reveals or internal reveals. For instance, through a window 1.20 meters wide, with external reveals, at the remote point of CIII located in front of the window at the work plane, the light is about four and two thirds times more that which is admitted through the window with the internal reveals. With a window width of 1.80 meters, and in the same position, the window with the external reveals admits about three and a half times more light than is admitted by the window with the internal reveals. In the same way, the window with external reveals admits two and three quarter times the light that is admitted through the internal bevelled window with the size of 2.40 meters. The same is true for the window sizes of 3.00 meters and 3.60 meters. On the other hand, the window with square reveals admits about two to a maximum of four times the light that is admitted through the window with internal reveals, depending upon window size and the position of the reference points.

. At the other side of the room away from the window, the window with external reveals produces the superior lighting. For instance for the window which is 1.20 meters in width and has external reveals at reference point AI, twice the amount of light is admitted by the window with internal reveals. The window with square reveals admits

Room = 4.00 x 3.50 x 2.25 m

only about one and a half times the light that is admitted through the latter. This happens for all reference points no matter where their position is in the room.

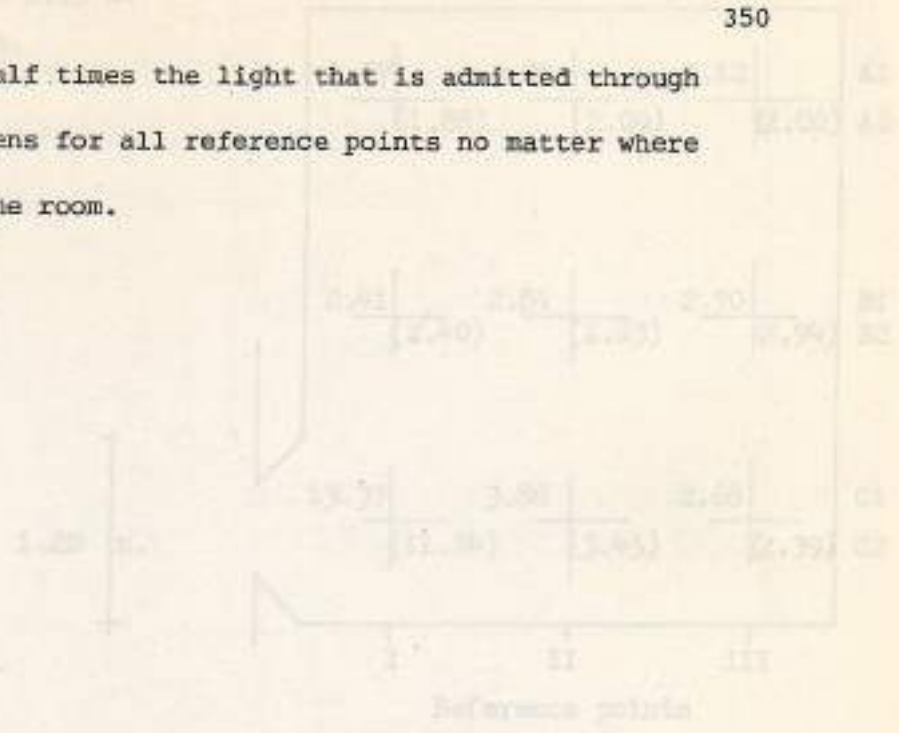

Plan 1490

- Light Source = NATURAL
- Readings = On work plane
- = Wardrobe
- = Wardrobe on concrete

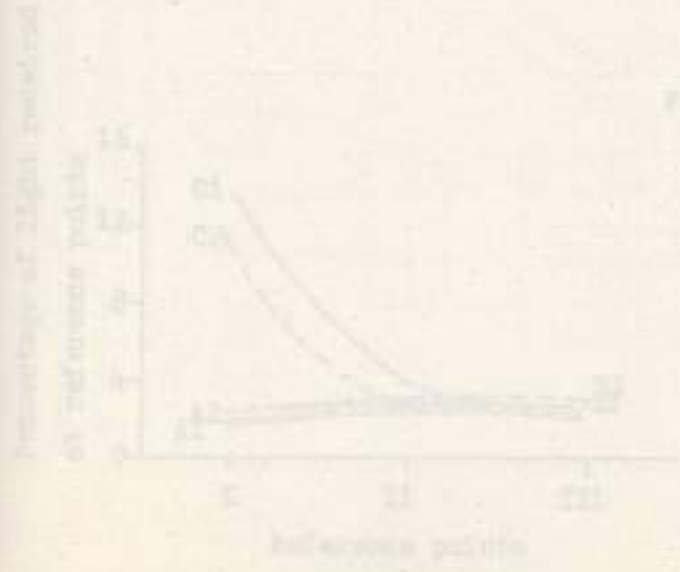

Fig. 115 Performance of window 1.20 x 1.30 meters having panels devoted to the interior

Room = 4.00 x 3.50 x 2.75 m.

Window = 1.20 x 1.30 m.

Sill = 0.90 m.

1.20 m.

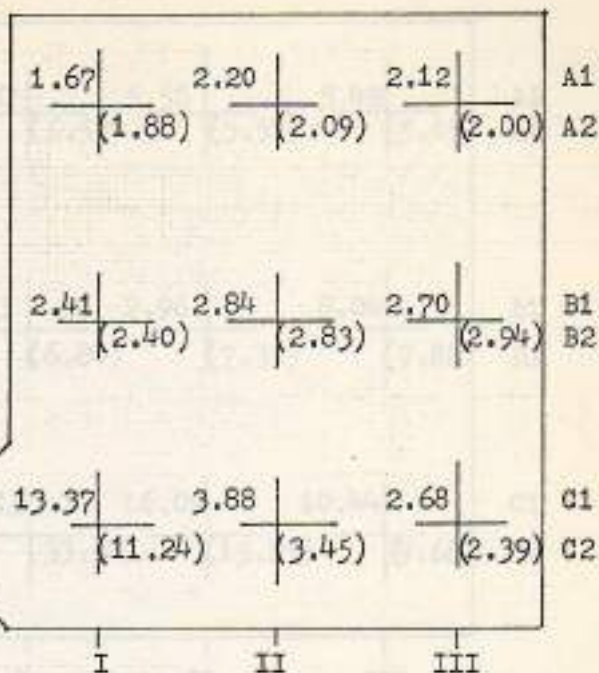

Reference points

Plan 1:50

Light source = NATURAL

Readings = On work plane

----- = Model on lawn

————— = Model on concrete

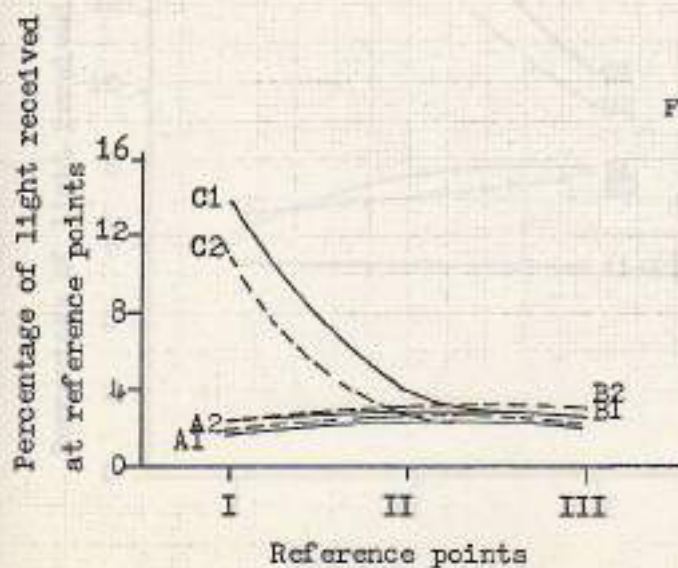

Fig. 115 Performance of window 1.20 x 1.30 Meters having reveals beveled to the interior

Room = 4.00 x 3.50 x 2.75 m.

Window = 1.20 x 1.30 m,

Sill = 0.90 m.

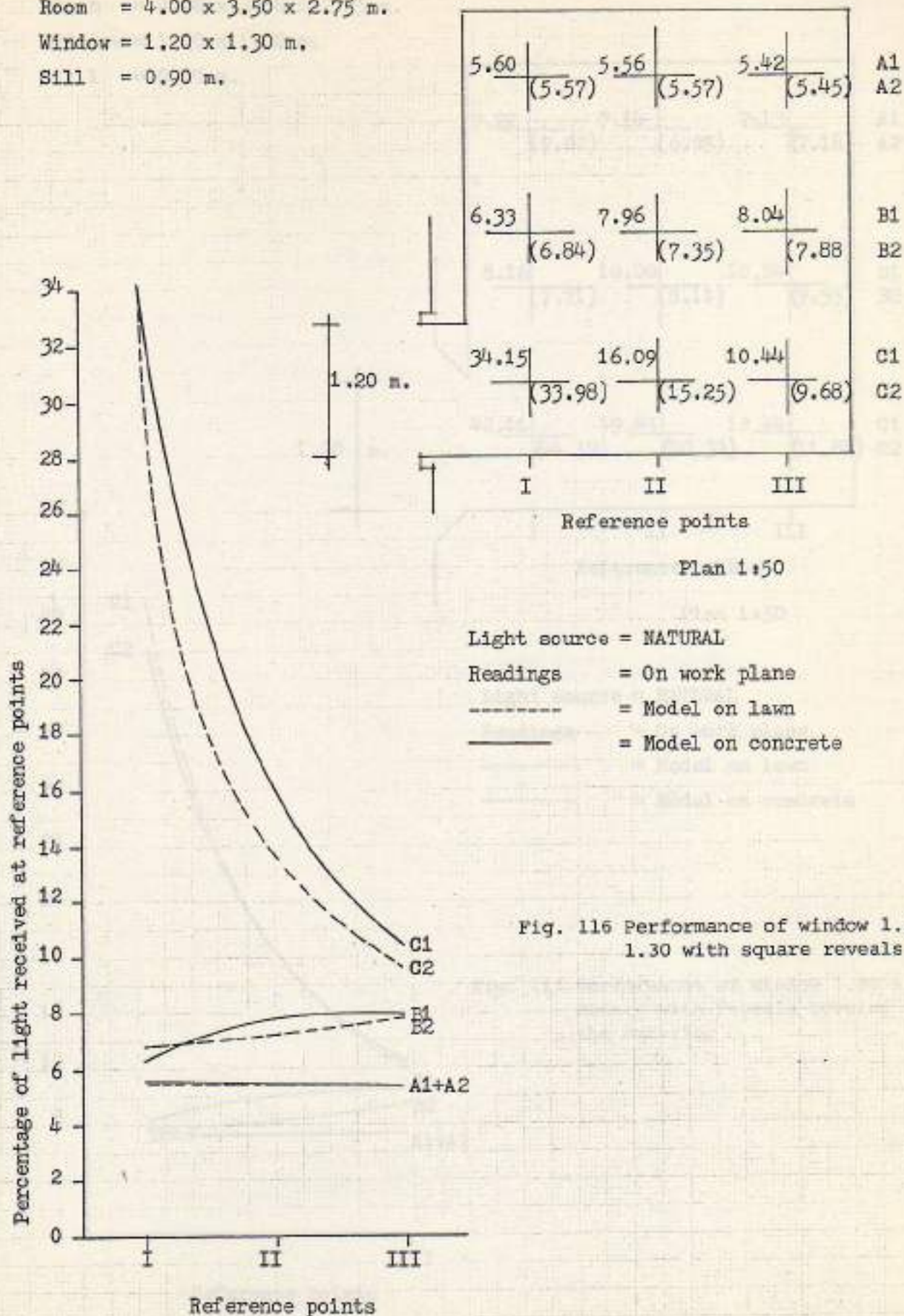
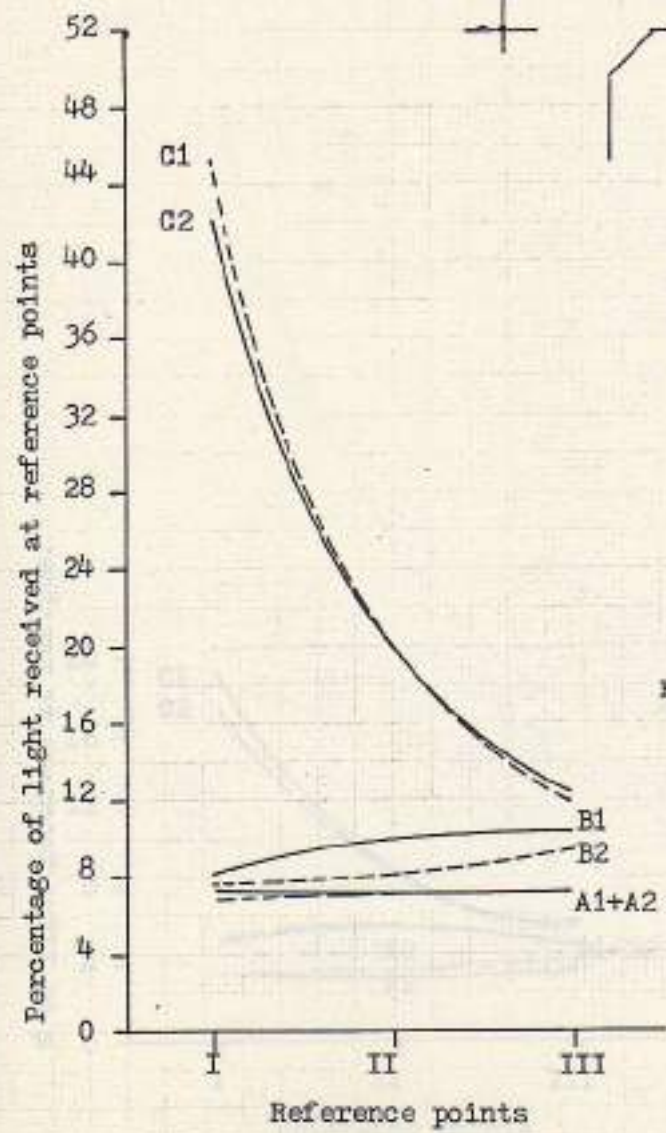
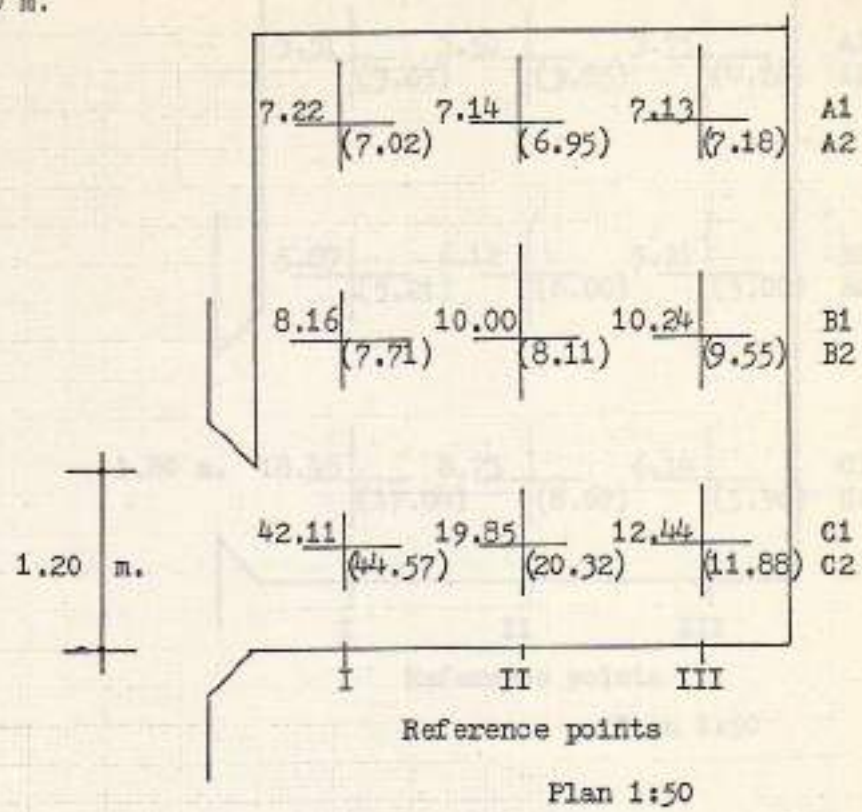

Fig. 116 Performance of window 1.20 x 1.30 with square reveals

Room = 4.00 x 3.50 x 2.75 m.
 Window = 1.20 x 1.30 m.
 Sill = 0.90 m.



Light source = NATURAL
 Readings = On work plane
 ----- = Model on lawn
 _____ = Model on concrete

Fig. 117 Performance of window 1.20 x 1.30 Meters with reveals beveled to the exterior

Room = 4.00 x 3.50 x 2.75 m.

Window = 1.80 x 1.30

Sill = 0.90 m.

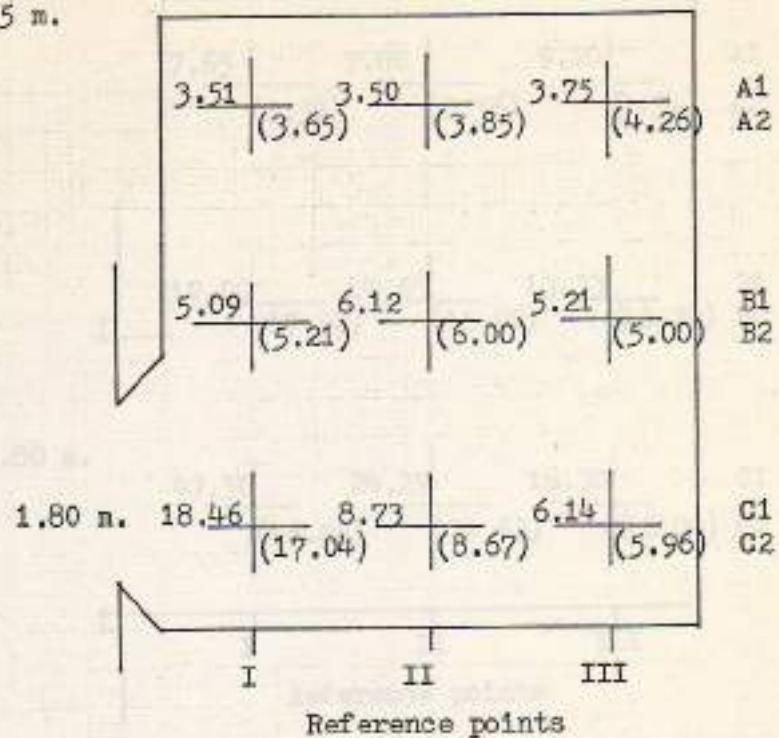

Plan 1:50

Light source = NATURAL

Readings = On work plane

----- = Model on lawn

————— = Model on concrete

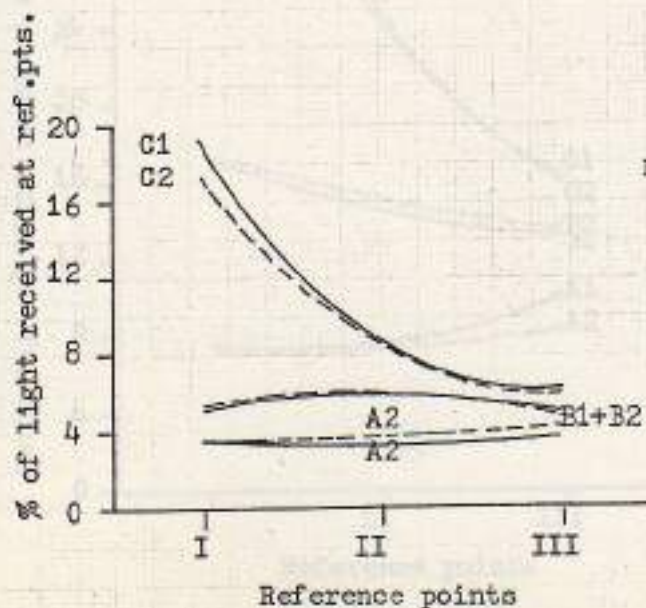
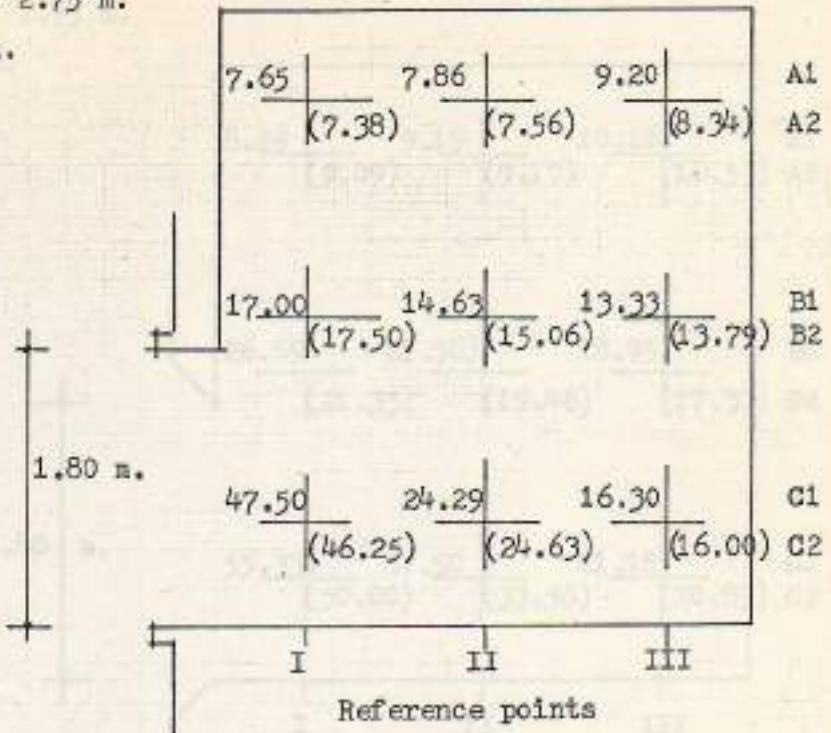

Fig. 118 Performance of window 1.80 x 1.30 Meters with reveals beveled to the interior

Room = 4.00 x 3.50 x 2.75 m.
 Window = 1.80 x 1.30 m.
 Sill = 0.90 m.



Plan 1:50

Light source = NATURAL
 Readings = On work plane
 ----- = Model on lawn
 _____ = Model on concrete

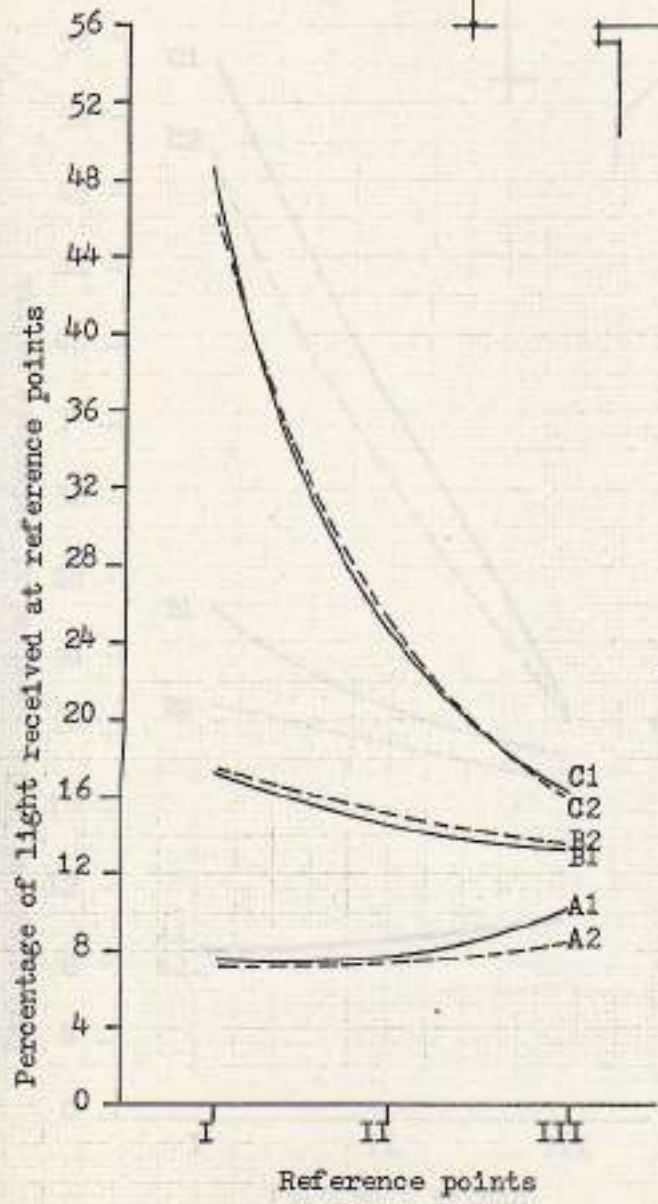
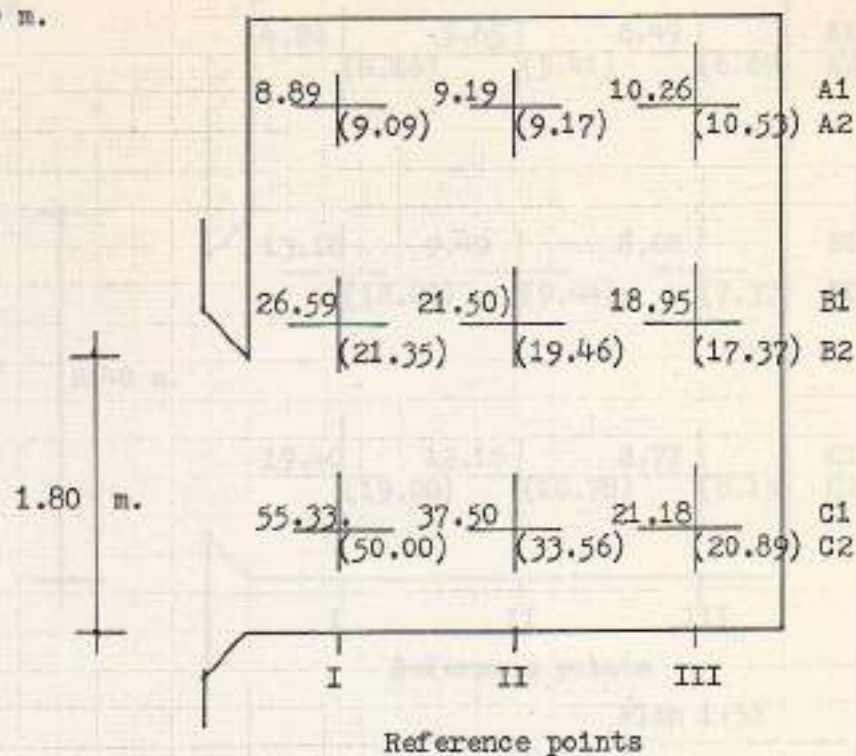

Fig. 120 Performance of window 1.80 x 1.30 Meters with square reveals

Room = 4.00 x 3.50 x 2.75 m.

Window = 1.80 x 1.30 m.

Sill = 0.90 m.



Plan 1:50

Light source = NATURAL

Readings = On work plane

----- = Model on lawn

————— = Model on concrete

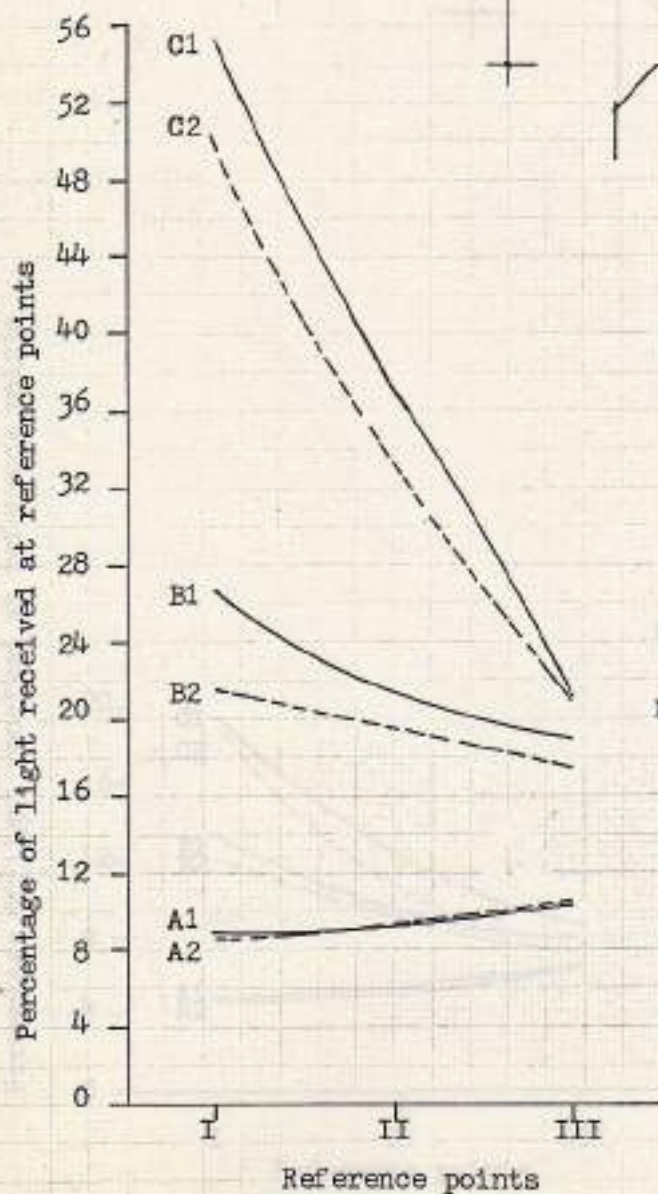
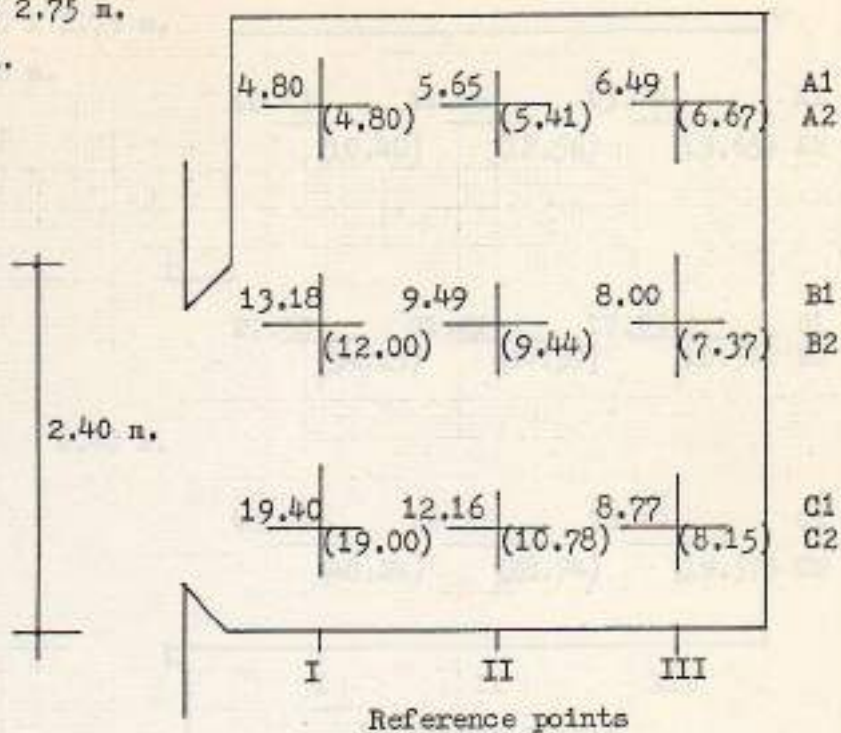

Fig. 121 Performance of window 1.80 x 1.30 Meters having reveals beveled to the exterior

Room = 4.00 x 3.50 x 2.75 m.

Window = 2.40 x 1.30 m.

Sill = 0.90 m.



Light source = NATURAL

Readings = On work plane

----- = Model on lawn

———— = Model on concrete

Fig. 122 Performance of window 2.40 x 1.30 Meters having reveals beveled to the interior

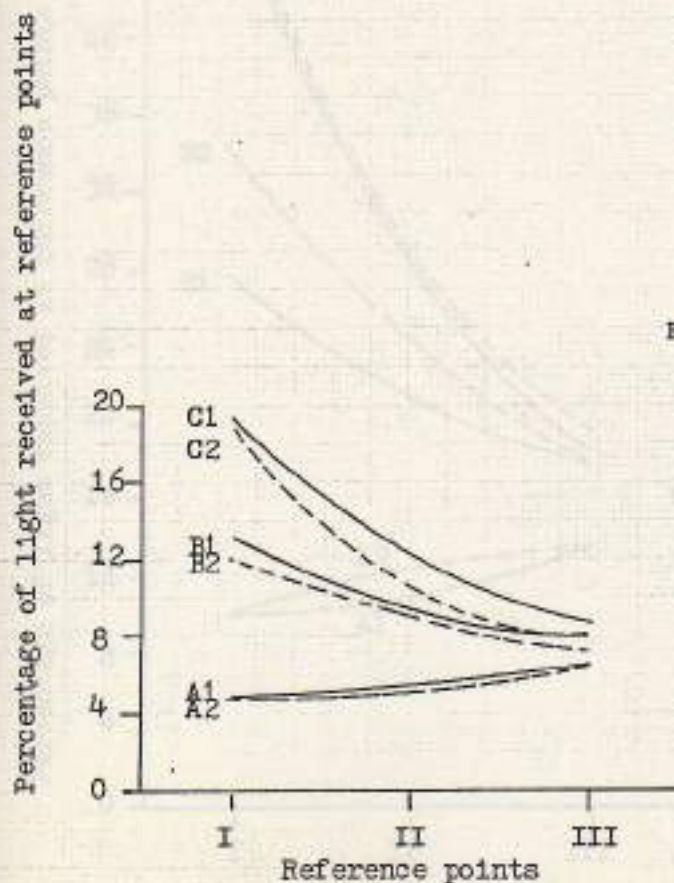

Room = 4.00 x 3.50 x 2.75 m.

Window = 2.40 x 1.30 m.

Sill = 0.90 m.

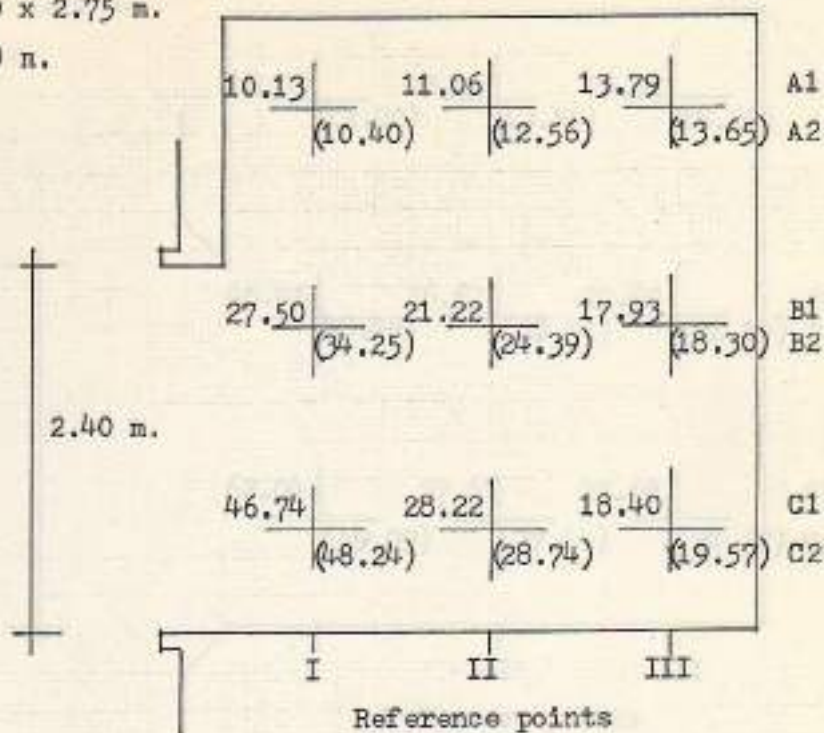

Plan 1:50

Percentage of light received at reference points

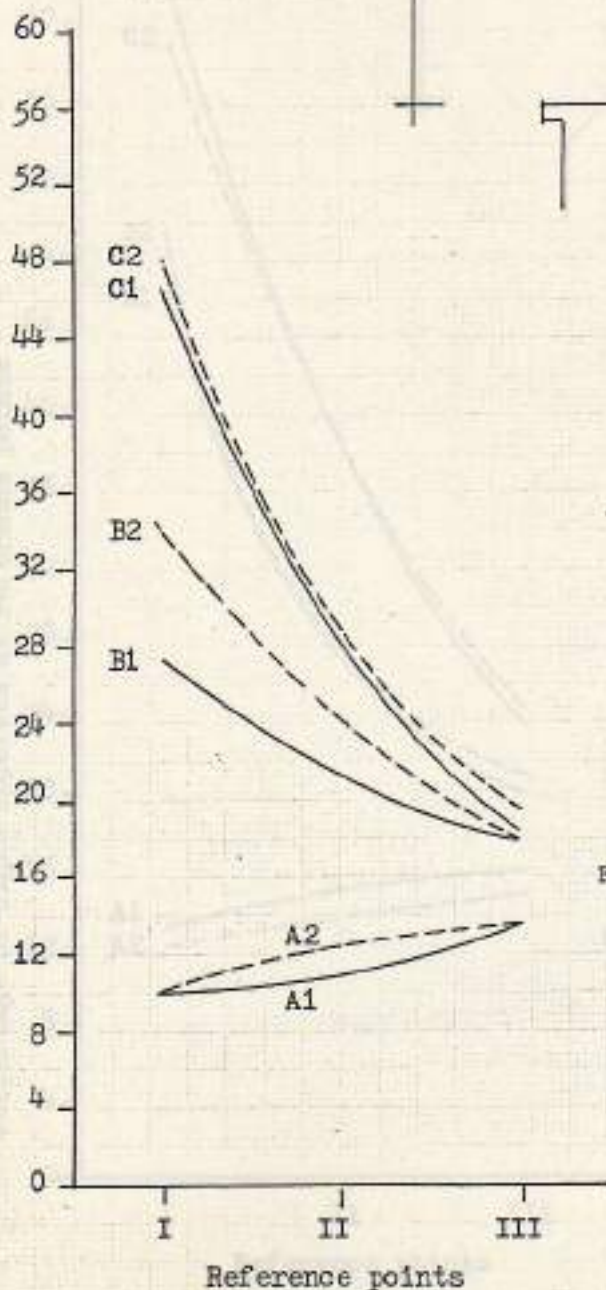

Light source = NATURAL

Readings = On work plane

----- = Model on lawn

————— = Model on concrete

Fig. 123 Performance of window 2.40 x 1.30 Meters having square reveals

Room = 4.00 x 3.50 x 2.75 m.

Window = 2.40 x 1.30 m.

Sill = 0.90 m.

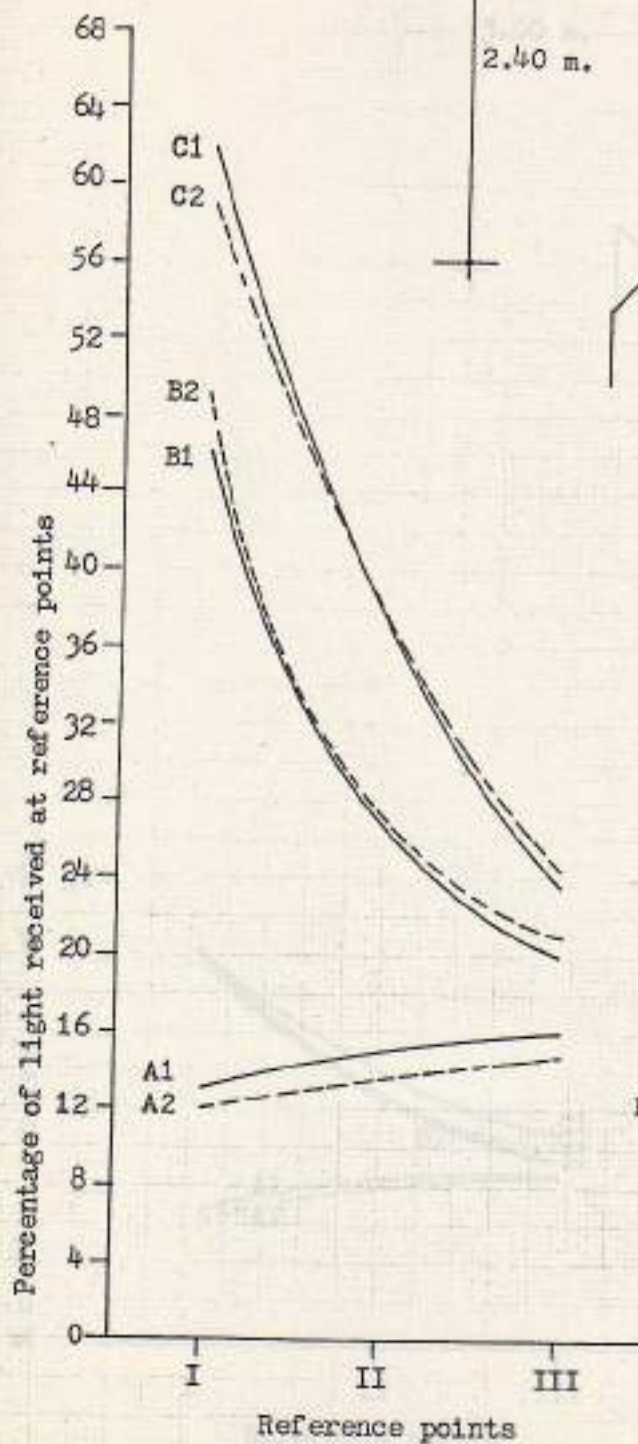
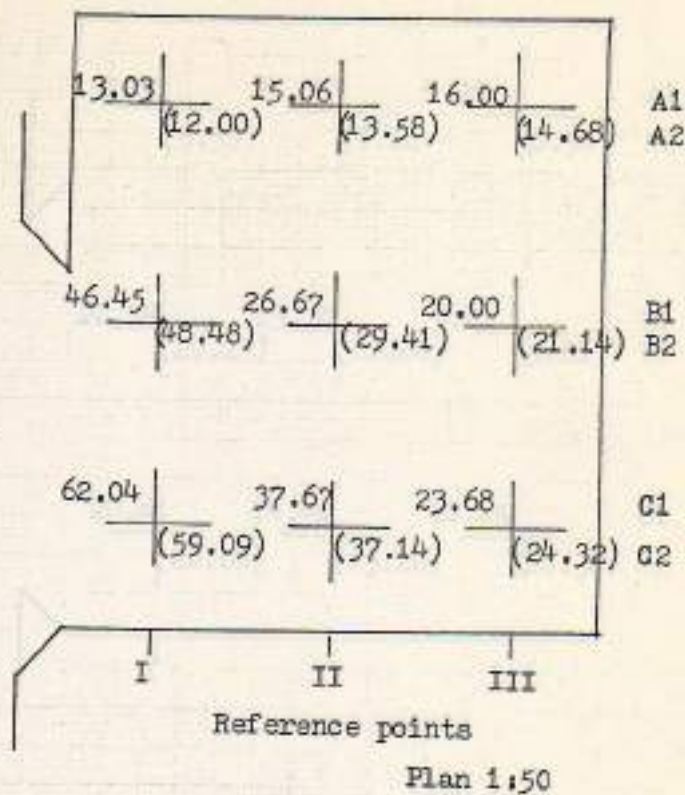

Light source = NATURAL

Readings = On work plane

----- = Model on lawn

———— = Model on concrete

Fig. 124 Performance of window 2.40 x 1.30 Meters having reveals beveled to the exterior

Room = 4.00 x 3.50 x 2.75 m

Window = 3.00 x 1.30 m.

Sill = 0.90 m.

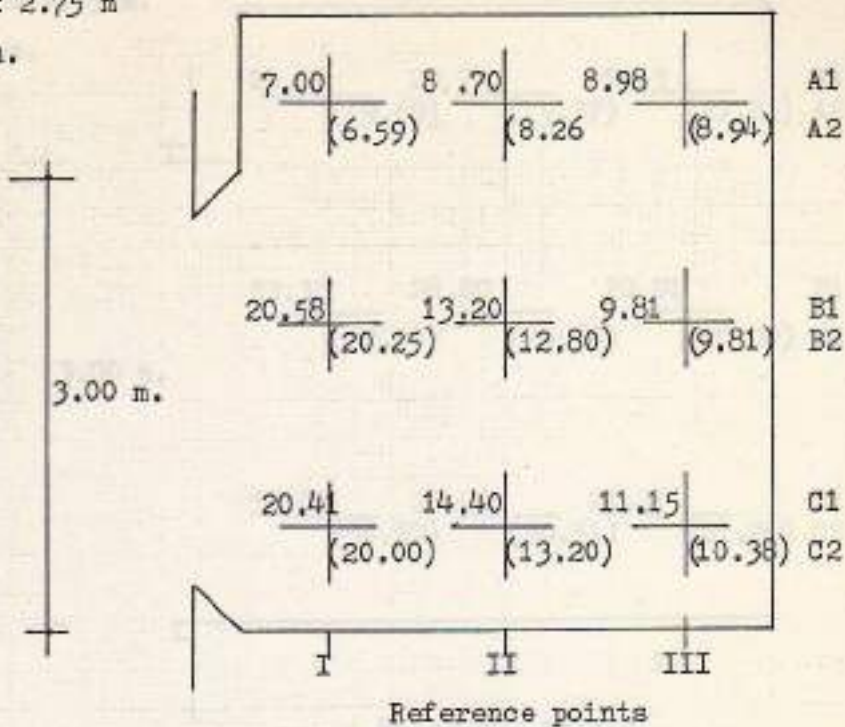

Light source = NATURAL

Readings = On Work plane

----- = Model on lawn

————— = Model on concrete

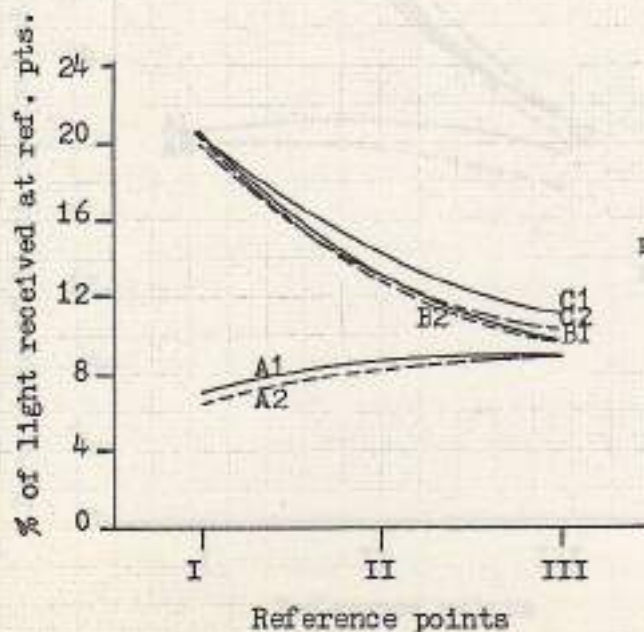
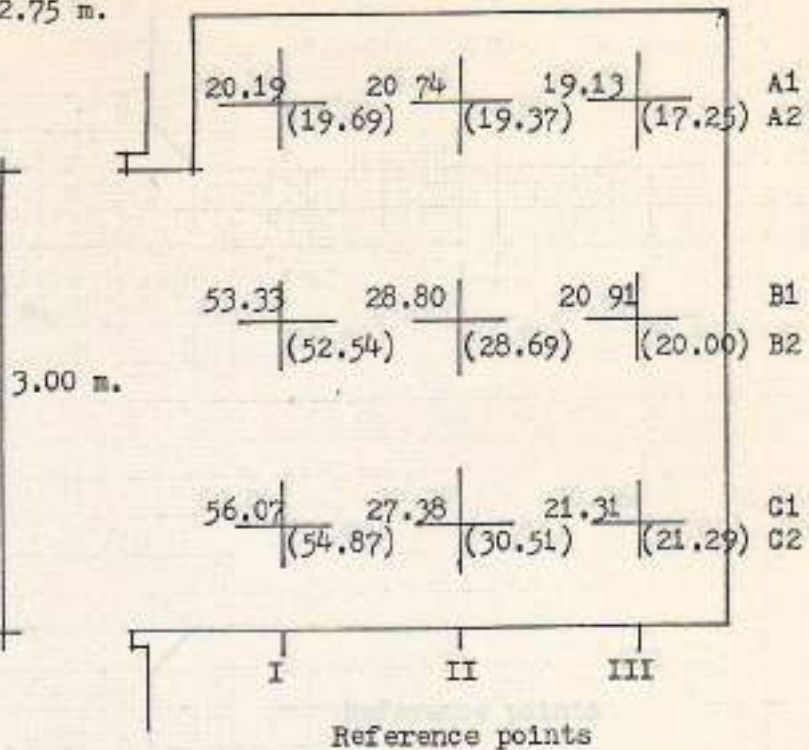

Fig. 125 Performance of window 3.00 x 1.30 Meters having reveals beveled to the interior

Room = 4.00 x 3.50 x 2.75 m.

Window = 3.00 x 1.30 m.

Sill = 0.90 m.



Plan 1:50

Percentage of light received at reference points

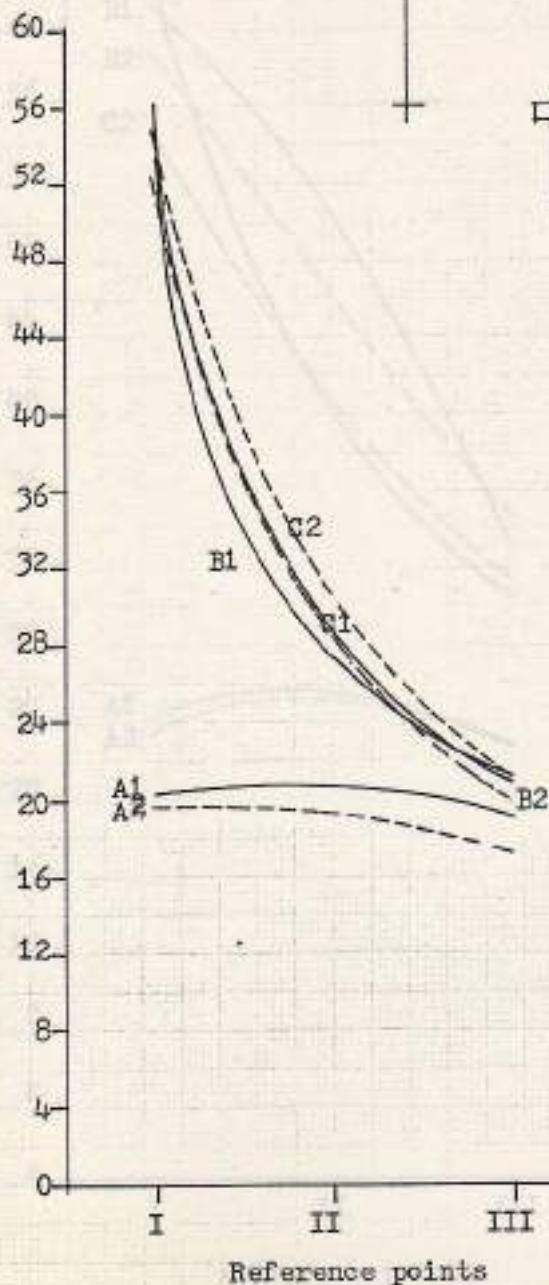

Light source = NATURAL

Readings = On work plane

----- = Model on lawn

————— = Model on concrete

Fig. 126 Performance of window 3.00 x 1.30 Meters having square reveals located at one side of the wall

Room = 4.00 x 3.50 x 2.75 m.

Window = 3.00 x 1.30 m.

Sill = 0.90 m.

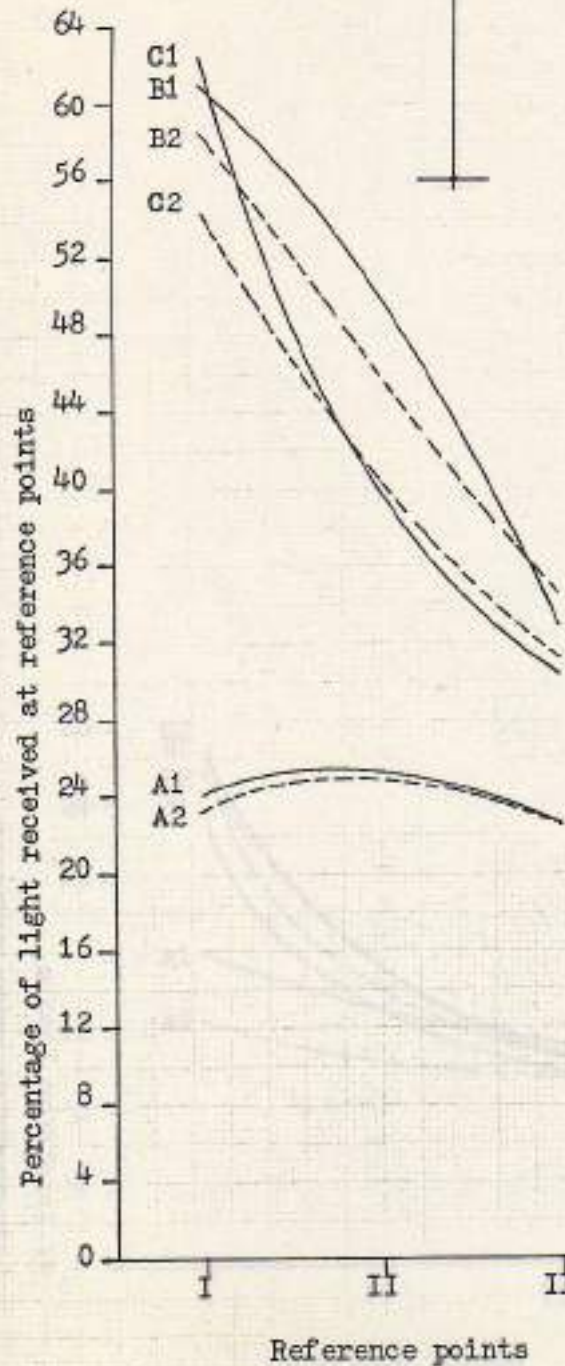
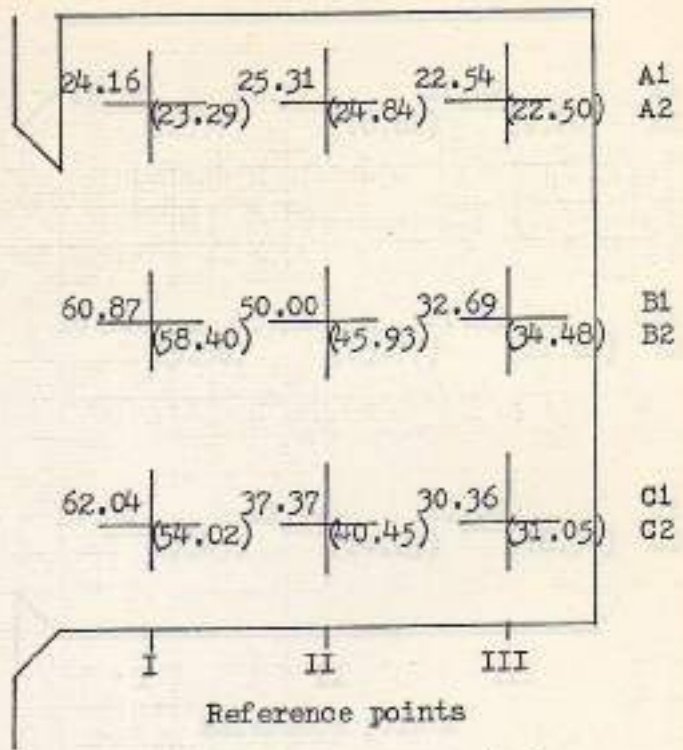

Light source = NATURAL
 Readings = On work plane
 ----- = Model on lawn
 _____ = Model on concrete

Fig. 127 Performance of window 3.00 x 1.30 Meters having reveals beveled to the exterior

Room = 4.00 x 3.50 2.75 m.
 Window = 3.60 x 1.30 m.
 Sill = 0.90 m.

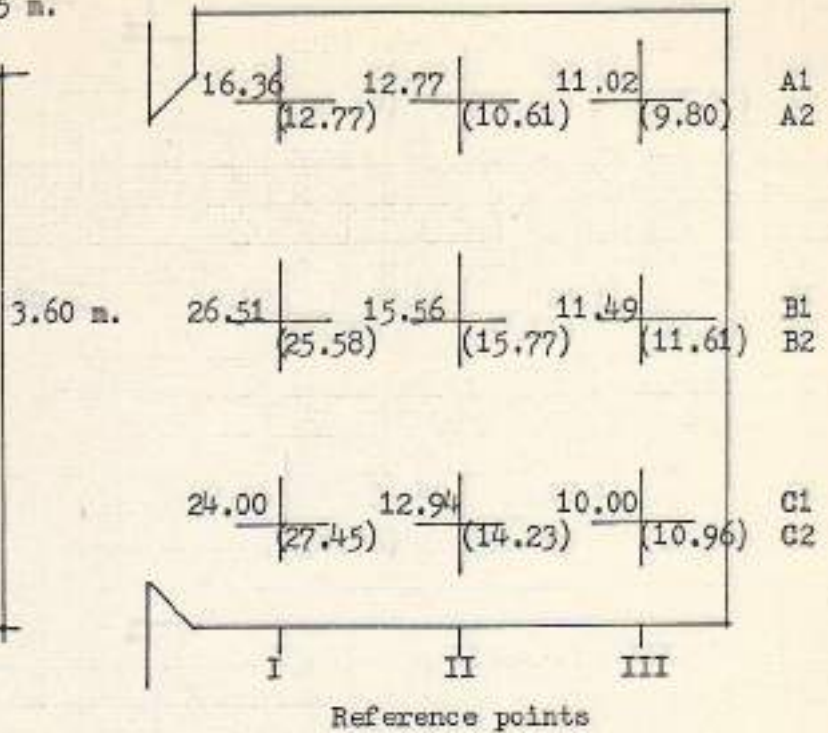

Reference points
 Plan 1:50

Light source = NATURAL
 Readings = On work plane
 ----- = Model on lawn
 ————— = Model on concrete

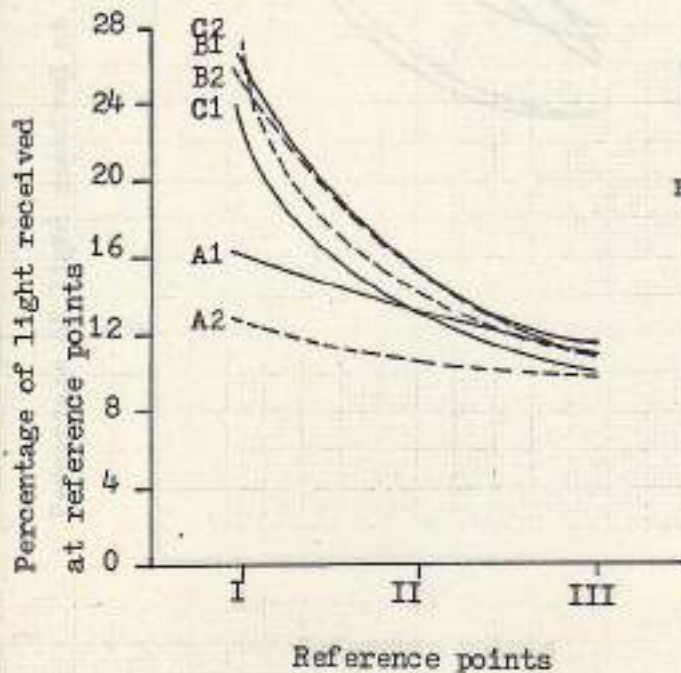
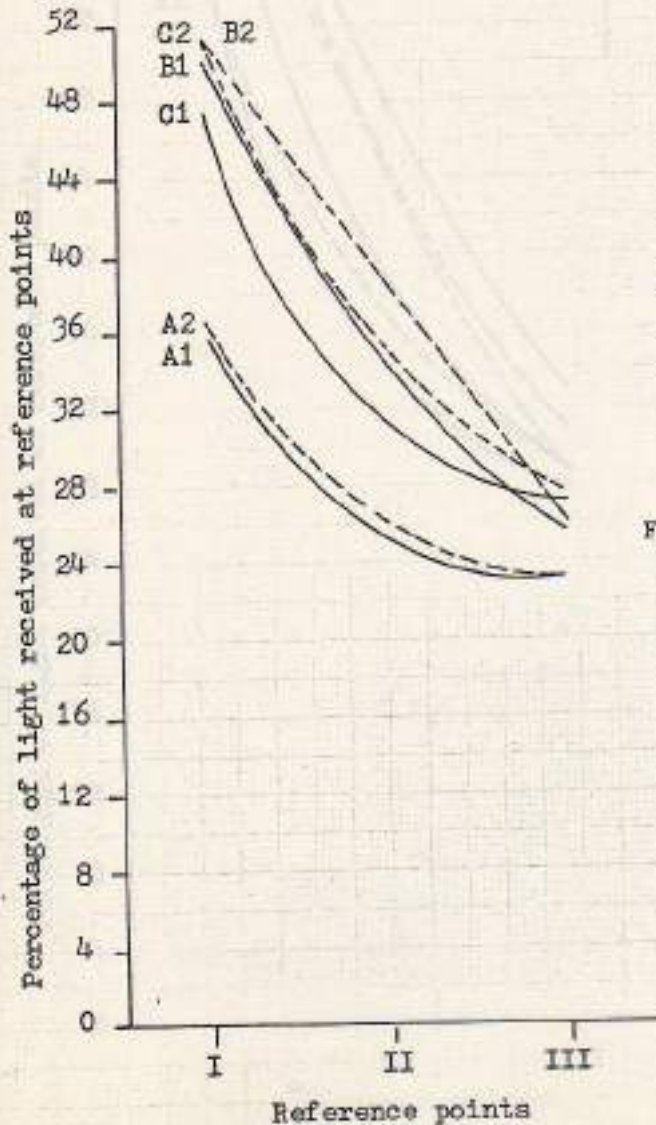
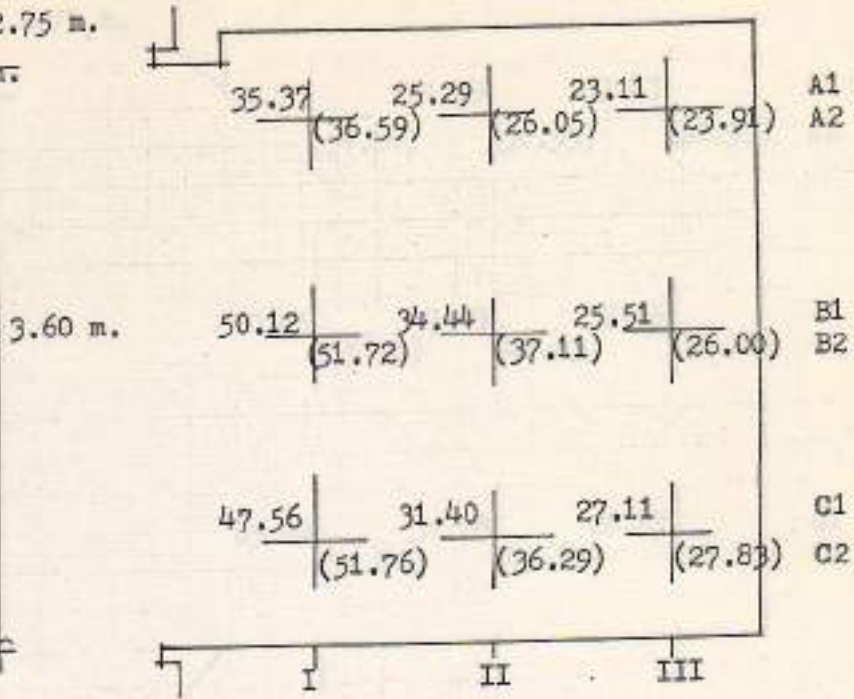

Fig. 128 Performance of window 3.60 x 1.30 Meters having reveals beveled to the interior

Room = 4.00 x 3.50 x 2.75 m.

Window = 3.60 x 1.30 m.

Sill = 0.90 m.



Reference points

Plan 1:50

Light source = NATURAL

Readings = On work plane

----- = Model on lawn

————— = Model on concrete

Fig. 129 Performance of window 3.60 x 1.30 Meters with square reveals

Room = 4.00 x 3.50 x 2.75 m.

Window = 3.60 x 1.30 m.

Sill = 0.90 m.

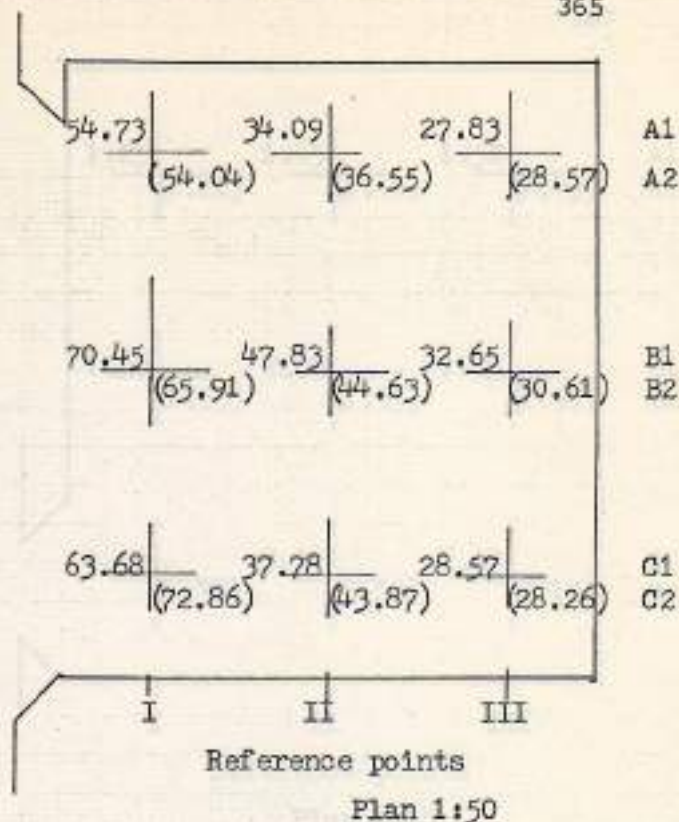
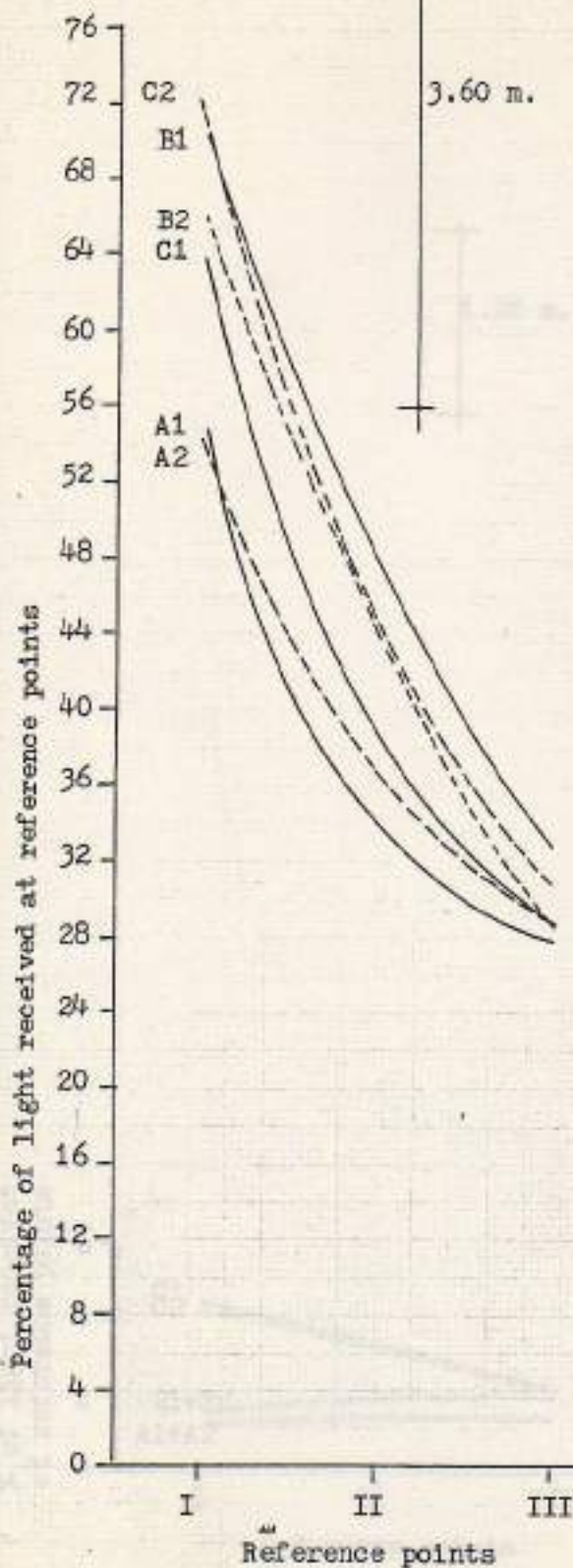

Light source = NATURAL

Readings = On work plane

----- = Model on lawn

————— = Model on concrete

Fig. 130 Performance of window 3.60 x 1.30 Meters having reveals beveled to the exterior

Room = 4.00 x 3.50 x 2.75 m.
 Window = 1.20 x 1.30 m.
 Sill = 0.90 m.

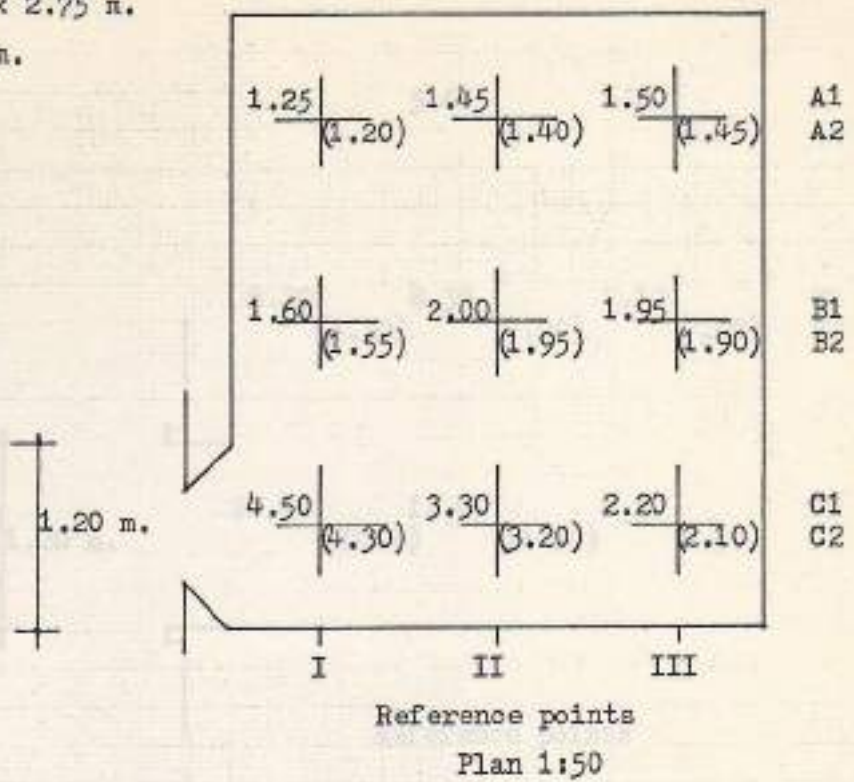

Light source = ARTIFICIAL
 Readings = On work plane
 ----- = Model on lawn
 _____ = Model on concrete

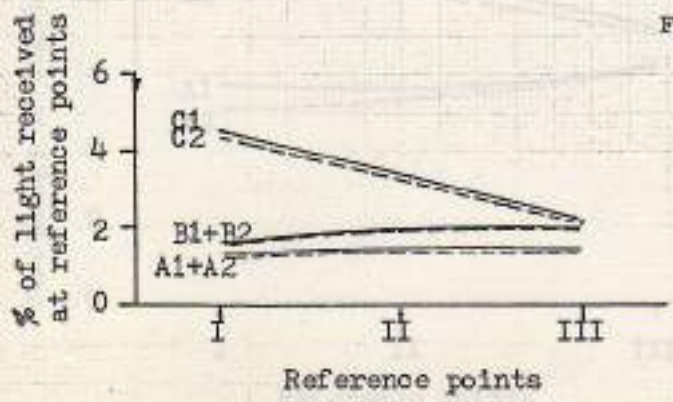
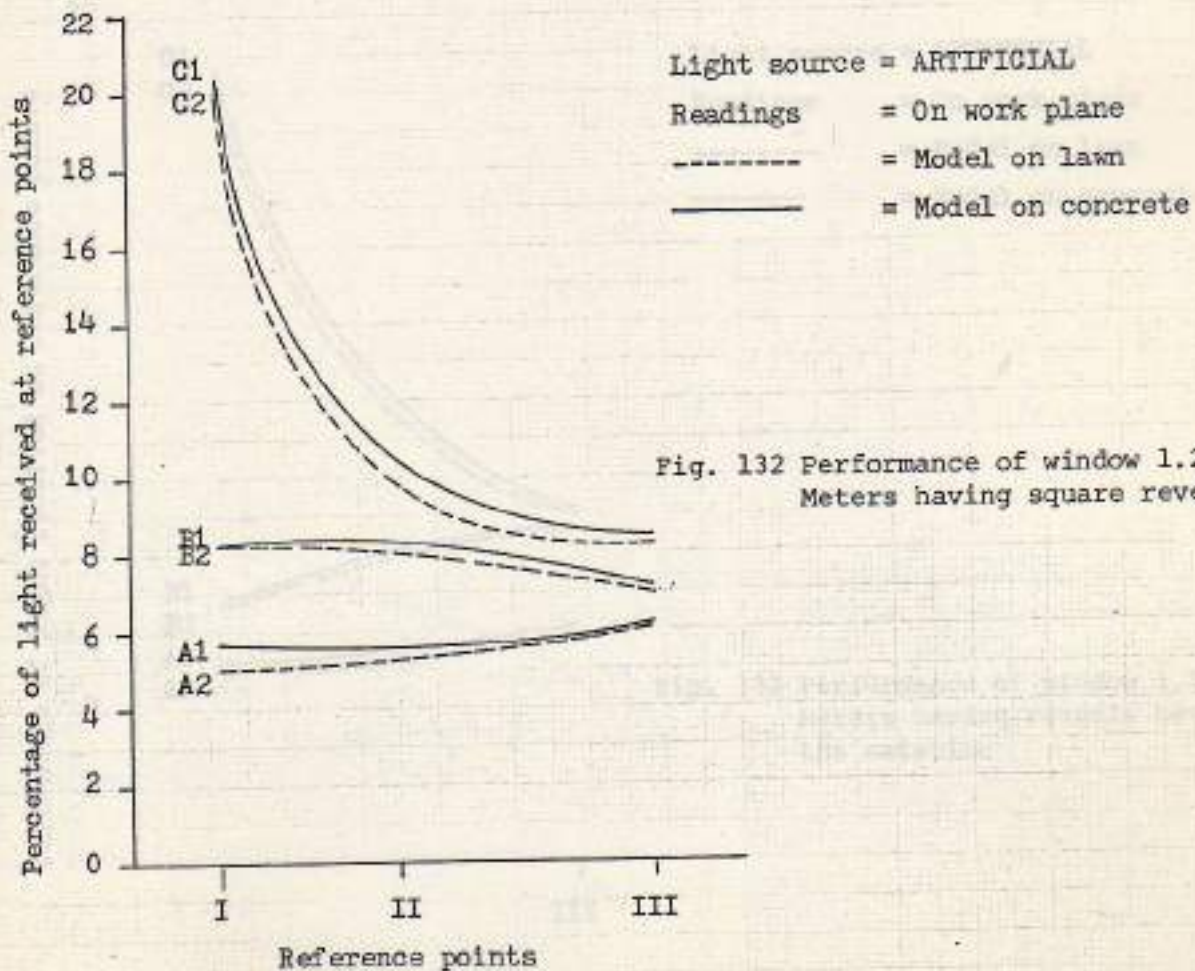
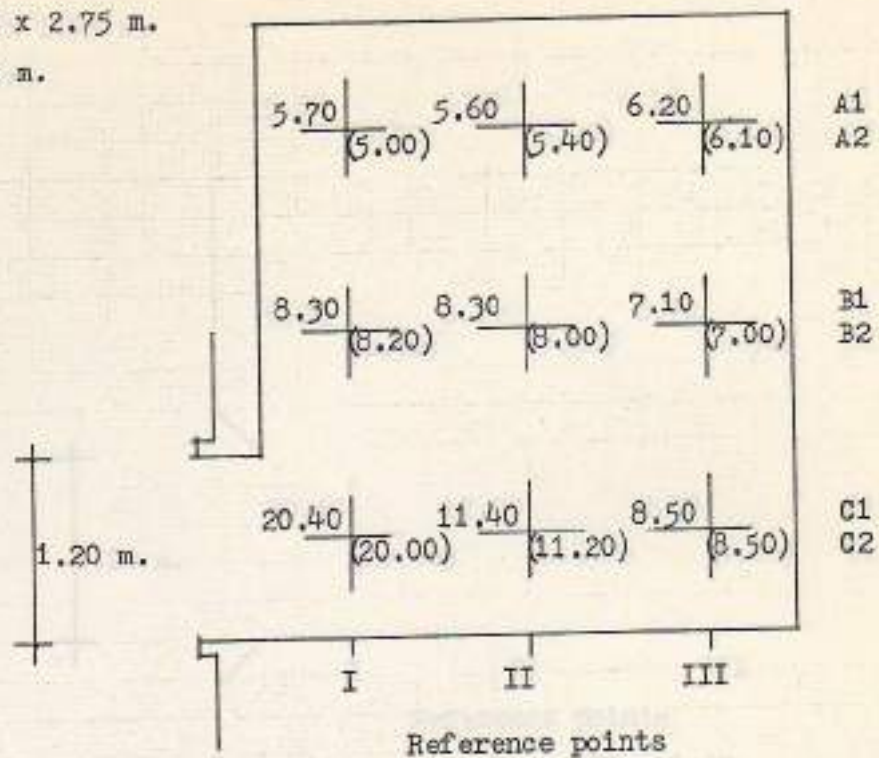

Fig. 131 Performance of window 1.20 x 1.30 Meters having reveals beveled to the interior

Room = 4.00 x 3.50 x 2.75 m.

Window = 1.20 x 1.30 m.

Sill = 0.90 m.



Room = 4.00 x 3.50 x 2.75 m.

Window = 1.20 x 1.30 m.

Sill = 0.90 m.

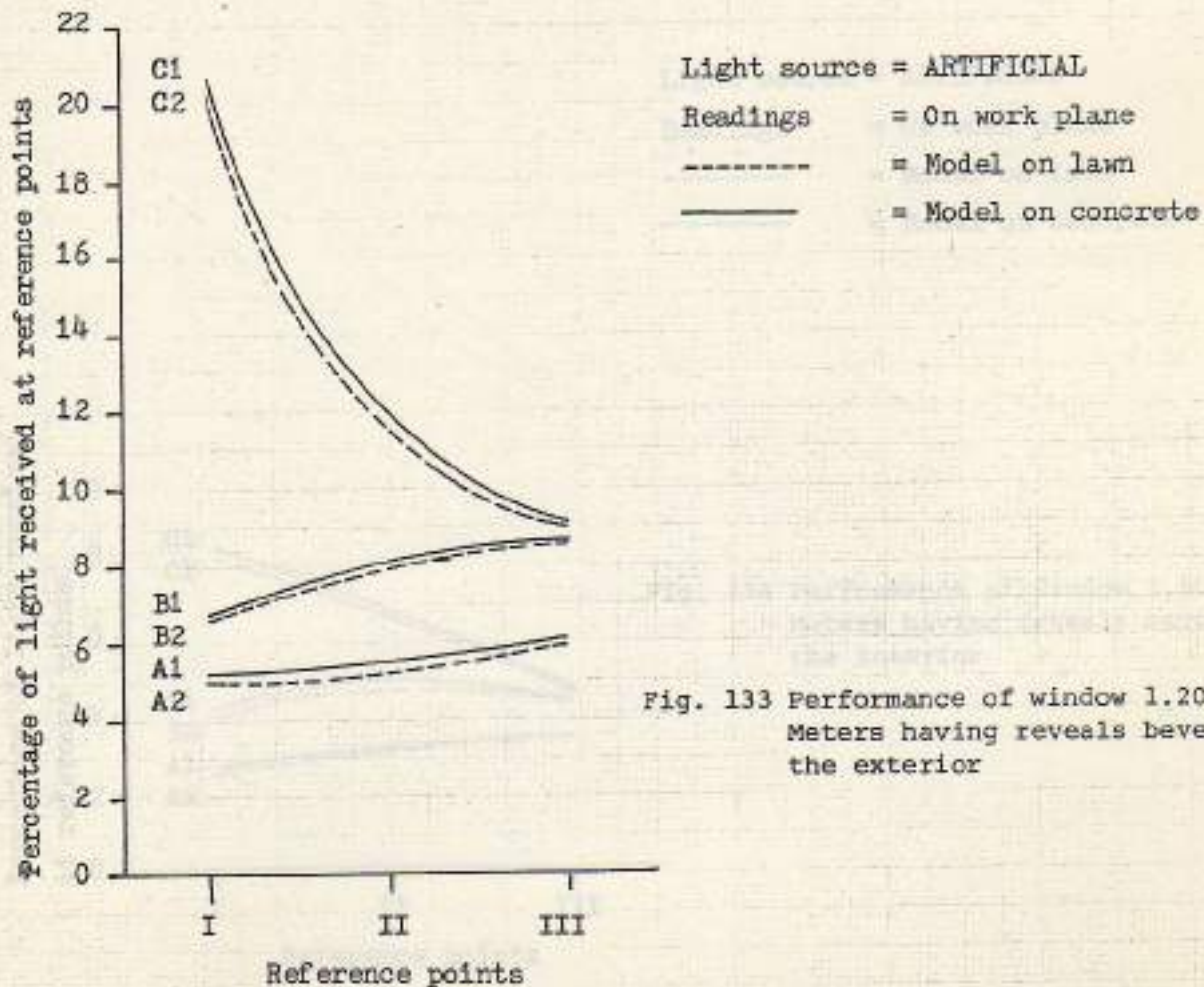
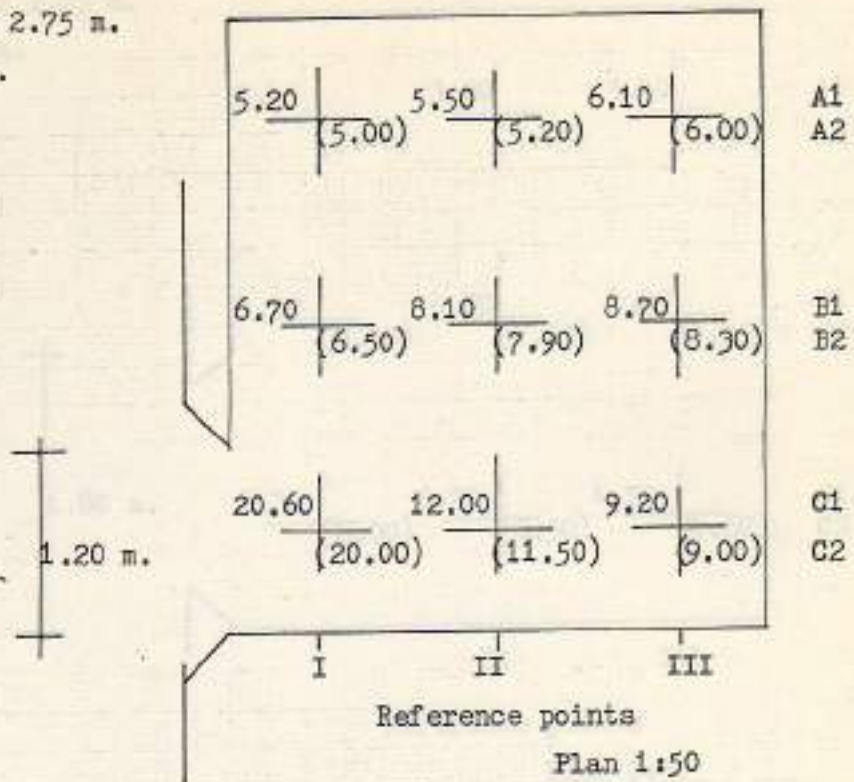
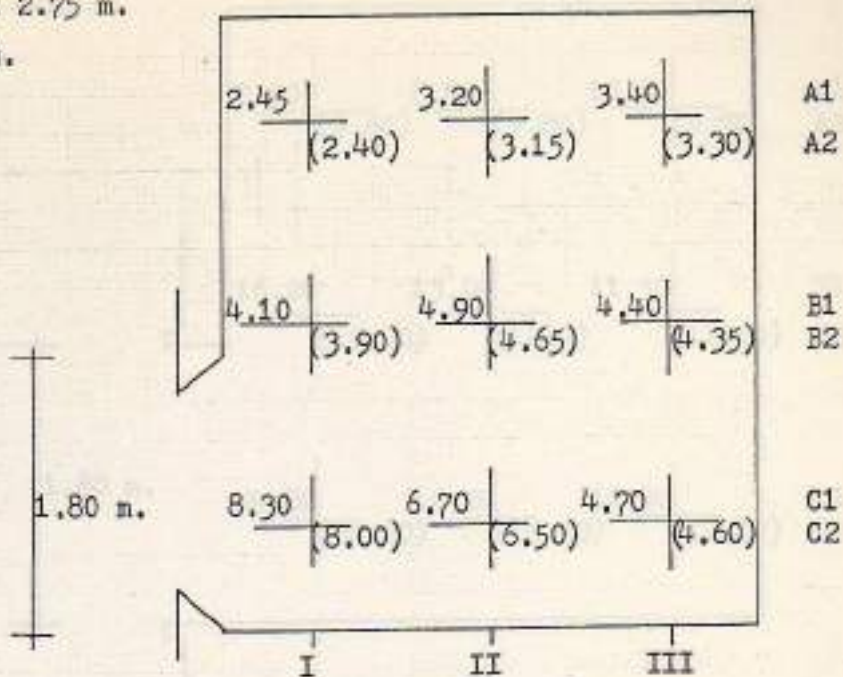

Fig. 133 Performance of window 1.20 x 1.30 Meters having reveals beveled to the exterior

Room = 4.00 x 3.50 x 2.75 m.

Window = 1.80 x 1.30 m.

Sill = 0.90 m.



Reference points
Plan 1:50

Light source = ARTIFICIAL
 Readings = On work plane
 ----- = Model on lawn
 _____ = Model on concrete

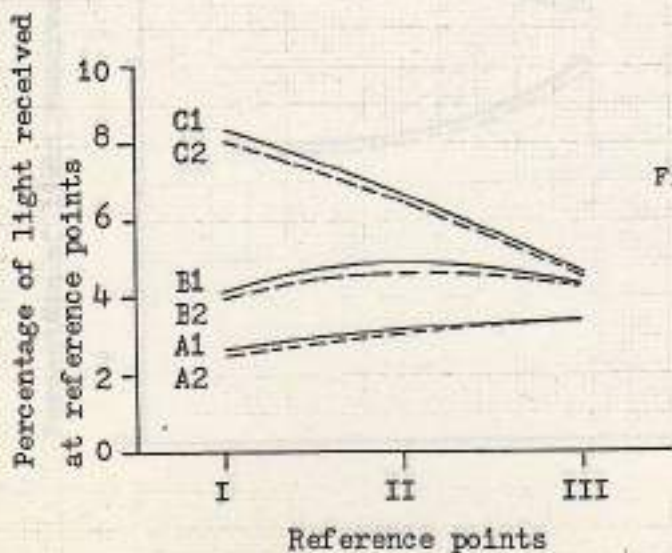

Fig. 134 Performance of window 1.80 x 1.30 Meters having reveals beveled to the interior

Room = 4.00 x 3.50 x 2.75 m.

Window = 1.80 x 1.30 m.

Sill = 0.90 m.

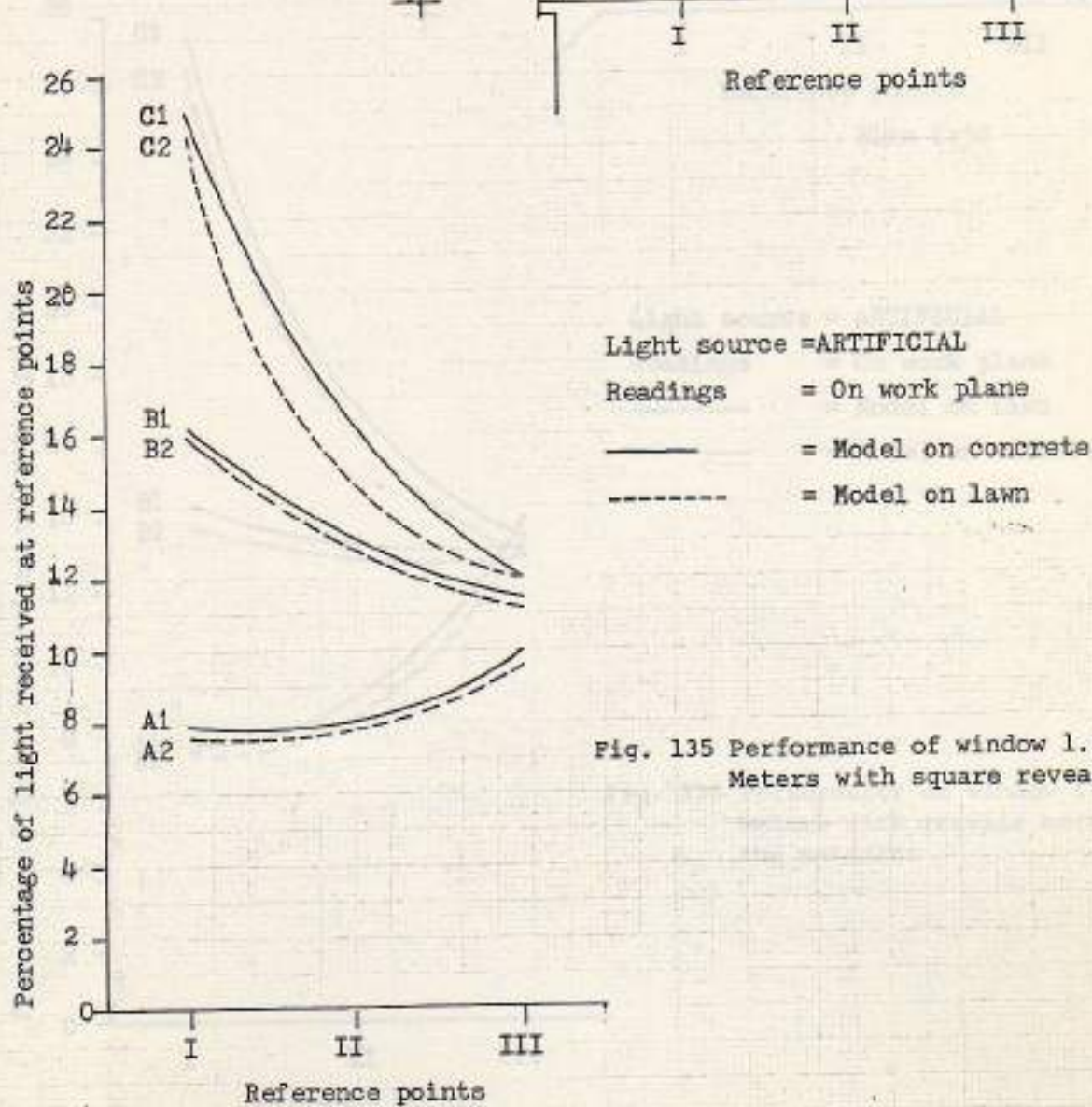
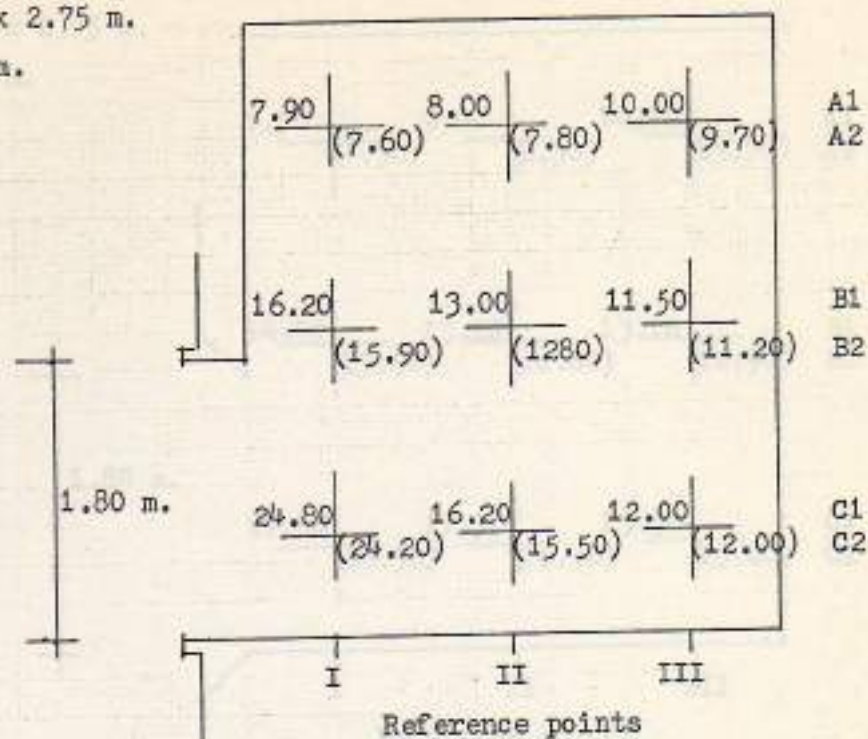
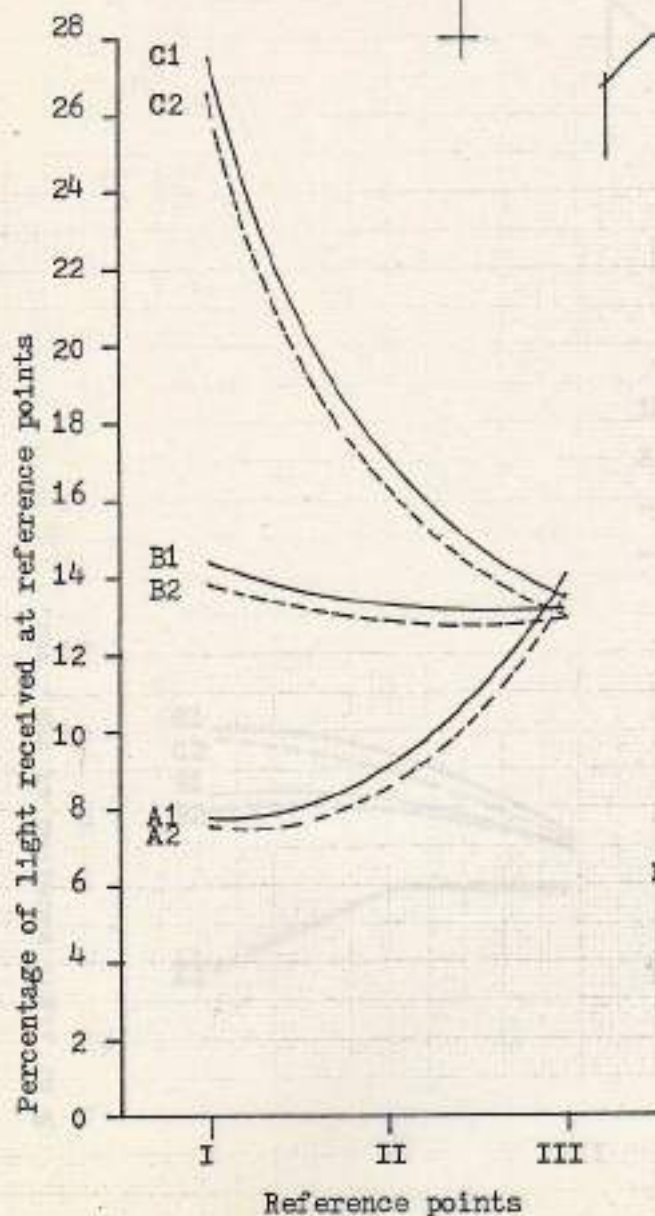
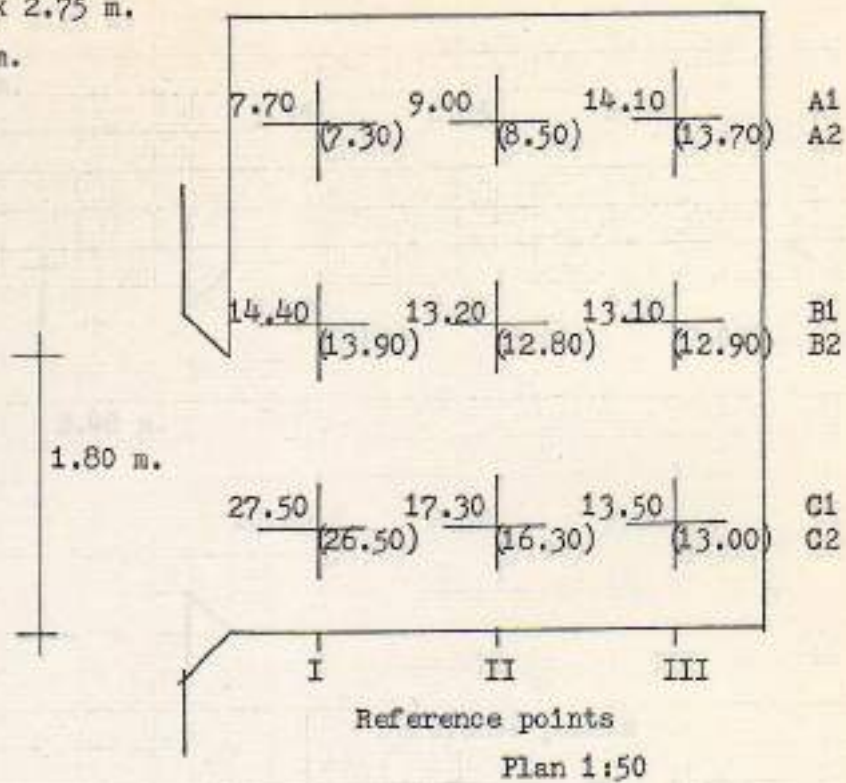

Fig. 135 Performance of window 1.80 x 1.30 Meters with square reveals

Room = 4.00 x 3.50 x 2.75 m.
 Window = 1.80 x 1.30 m.
 Sill = 0.90 m.



Light source = ARTIFICIAL
 Readings = On work plane
 ----- = Model on lawn
 _____ = Model on concrete

Fig. 136 Performance of window 1.80 x 1.30 Meters with reveals beveled to the exterior

Room = 4.00 x 3.50 x 2.75 m.

Window = 2.40 x 1.30 m.

Sill = 0.90 m.

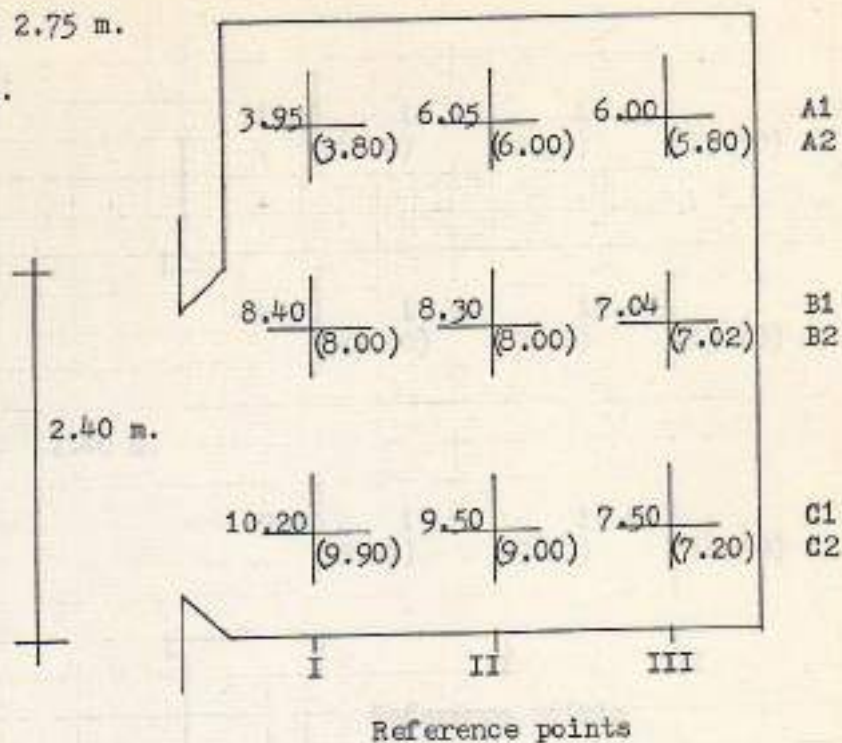

Light source = ARTIFICIAL

Readings = On work plane

----- = Model on lawn

————— = Model on concrete

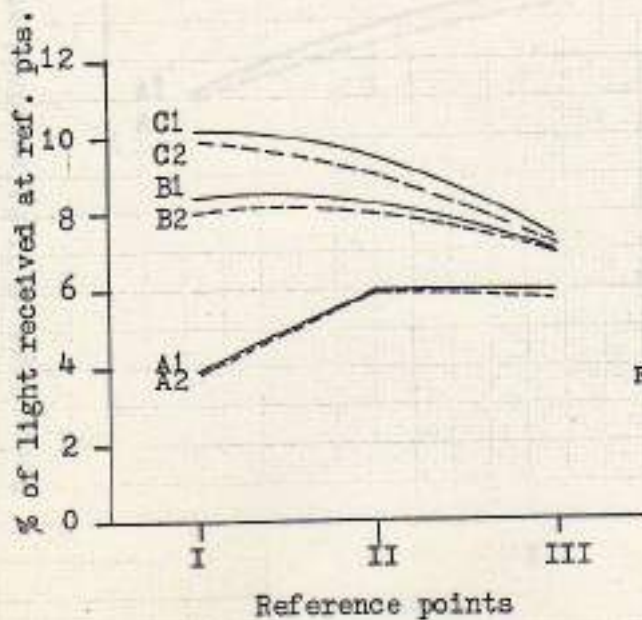
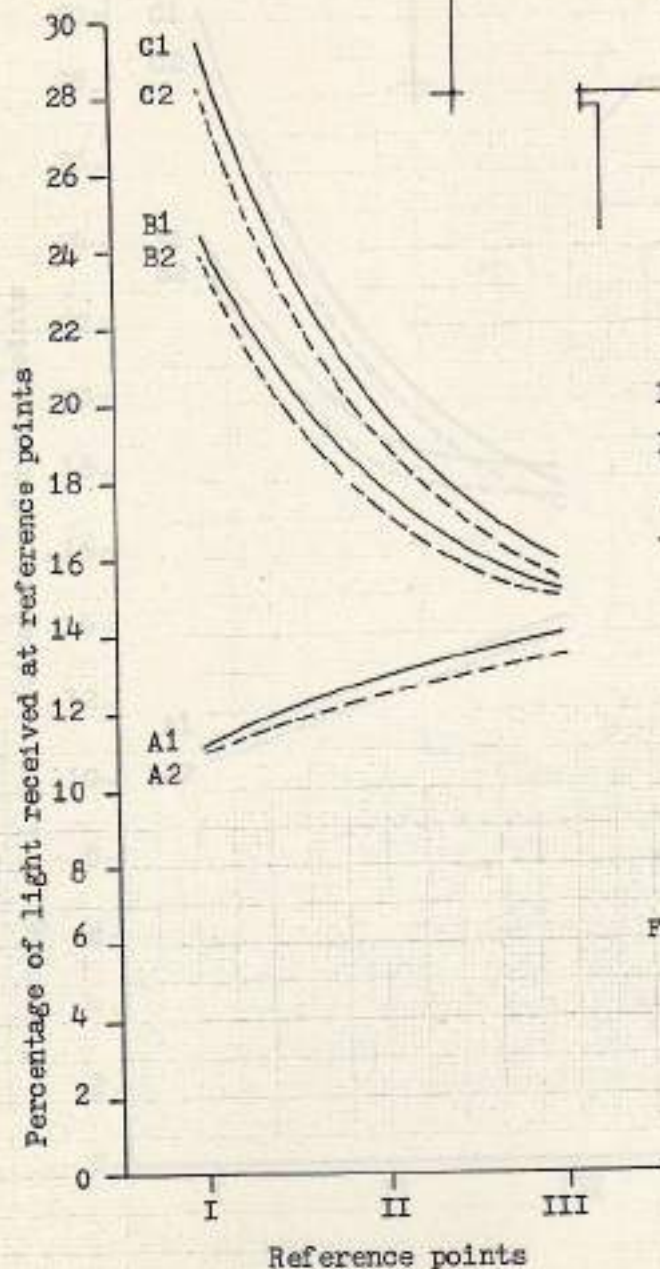
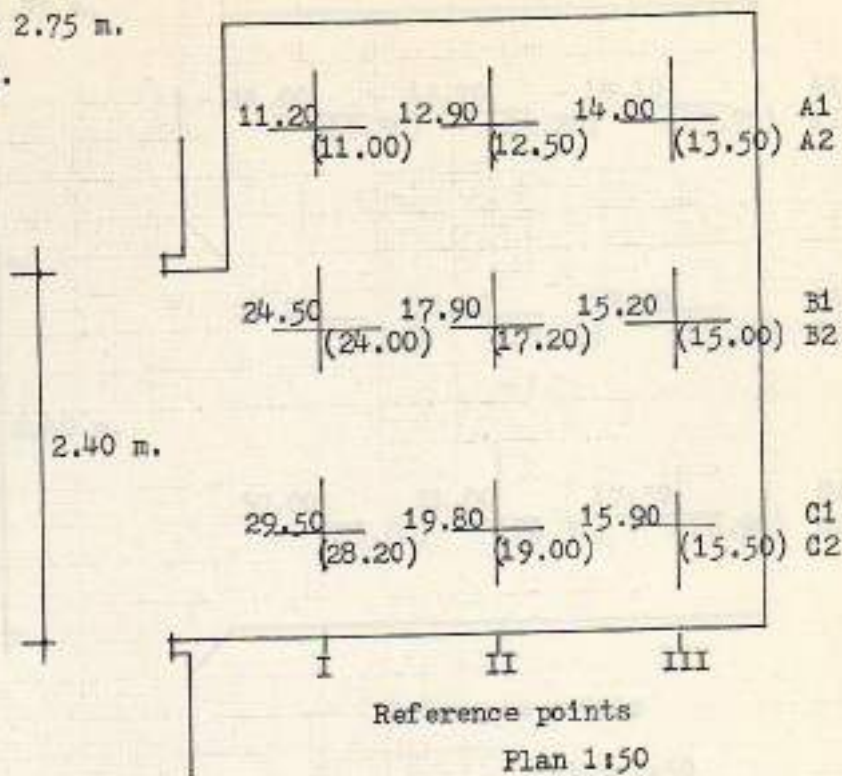

Fig. 137 Performance of window 2.40 x 1.30 Meters with reveals beveled to the interior

Room = 4.00 x 3.50 x 2.75 m.

Window = 2.40 x 1.30 m.

Sill = 0.90 m.



Light source = ARTIFICIAL
 Readings = On work plane
 ----- = Model on lawn
 _____ = Model on concrete

Fig. 138 Performance of window 2.40 x 1.30 Meters with square reveals

Room = 4.00 x 3.50 x 2.75 m.

Window = 2.40 x 1.30 m.

Sill = 0.90 m.

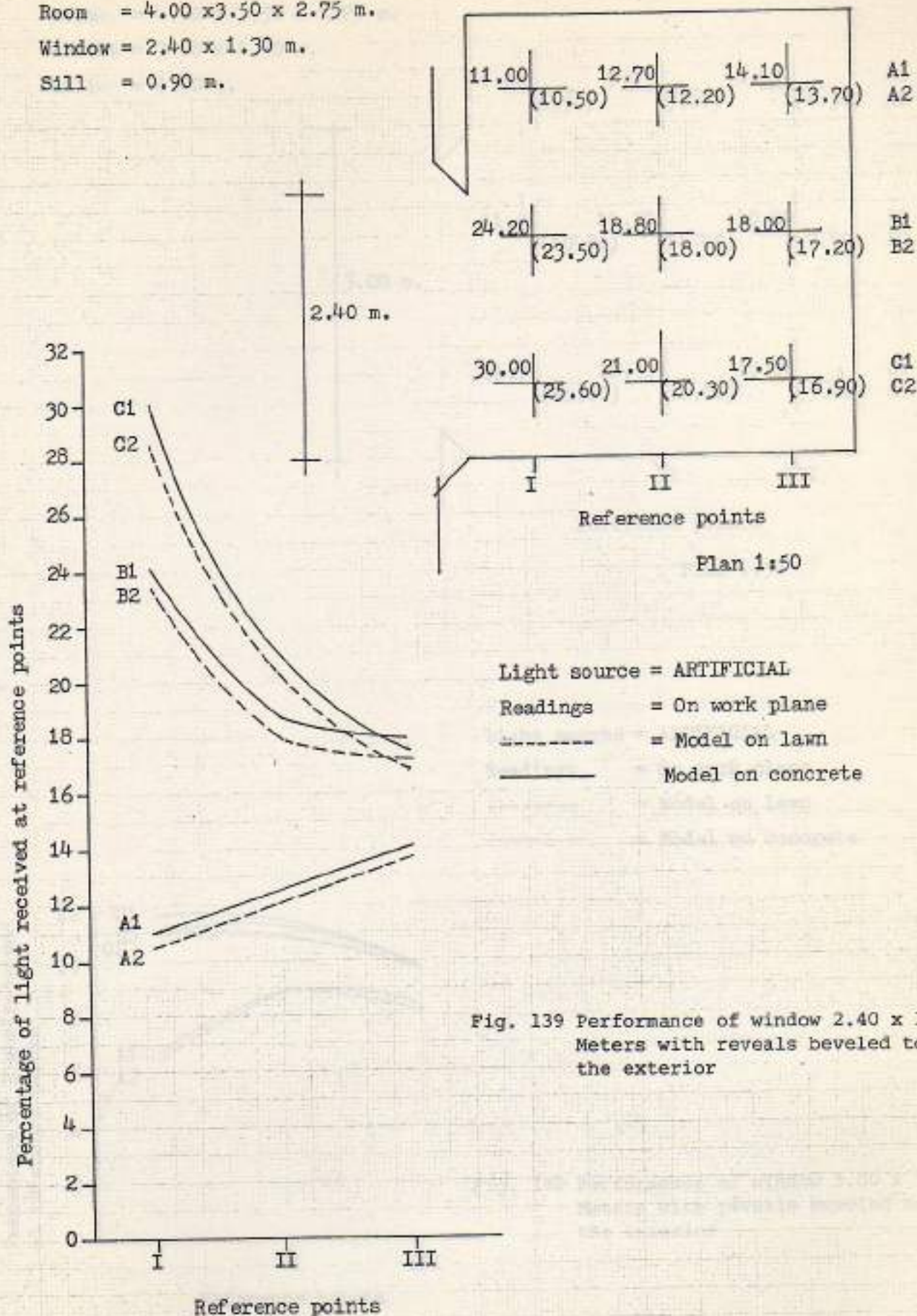
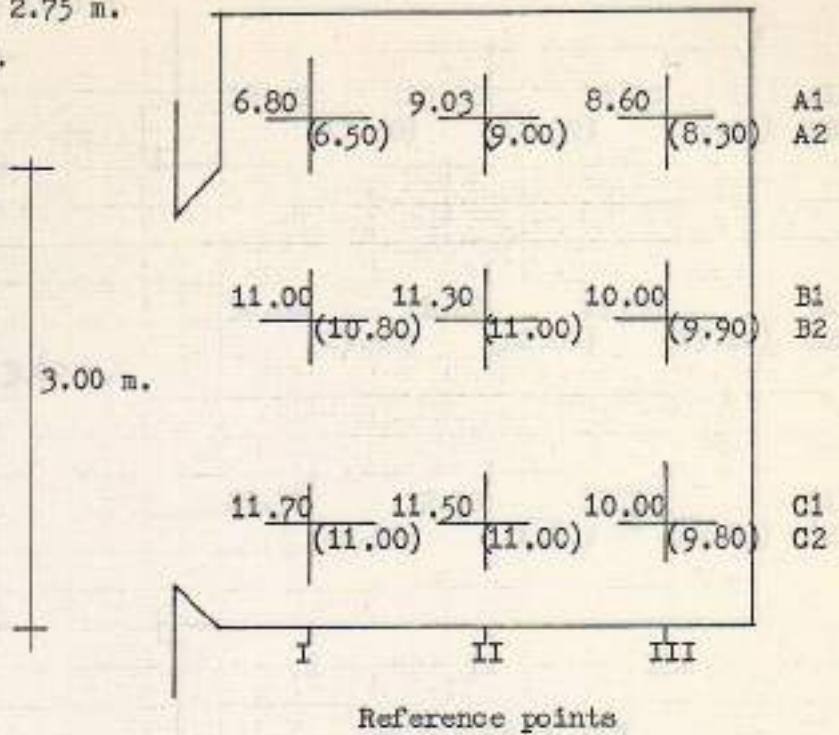

Fig. 139 Performance of window 2.40 x 1.30 Meters with reveals beveled to the exterior

Room = 4.00 x 3.50 x 2.75 m.

Window = 3.00 x 1.30 m.

Sill = 0.90 m.



Plan 1:50

Light source = ARTIFICIAL
 Readings = On work plane
 ----- = Model on lawn
 ————— = Model on concrete

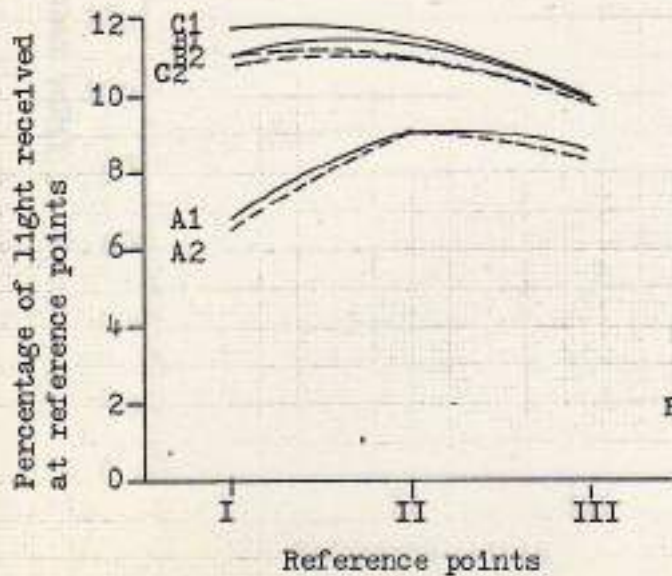

Fig. 140 Performance of window 3.00 x 1.30 Meters with reveals beveled to the interior

Room = 4.00 x 3.50 x 2.75 m.

Window = 3.00 x 1.30 m.

Sill = 0.90 m.

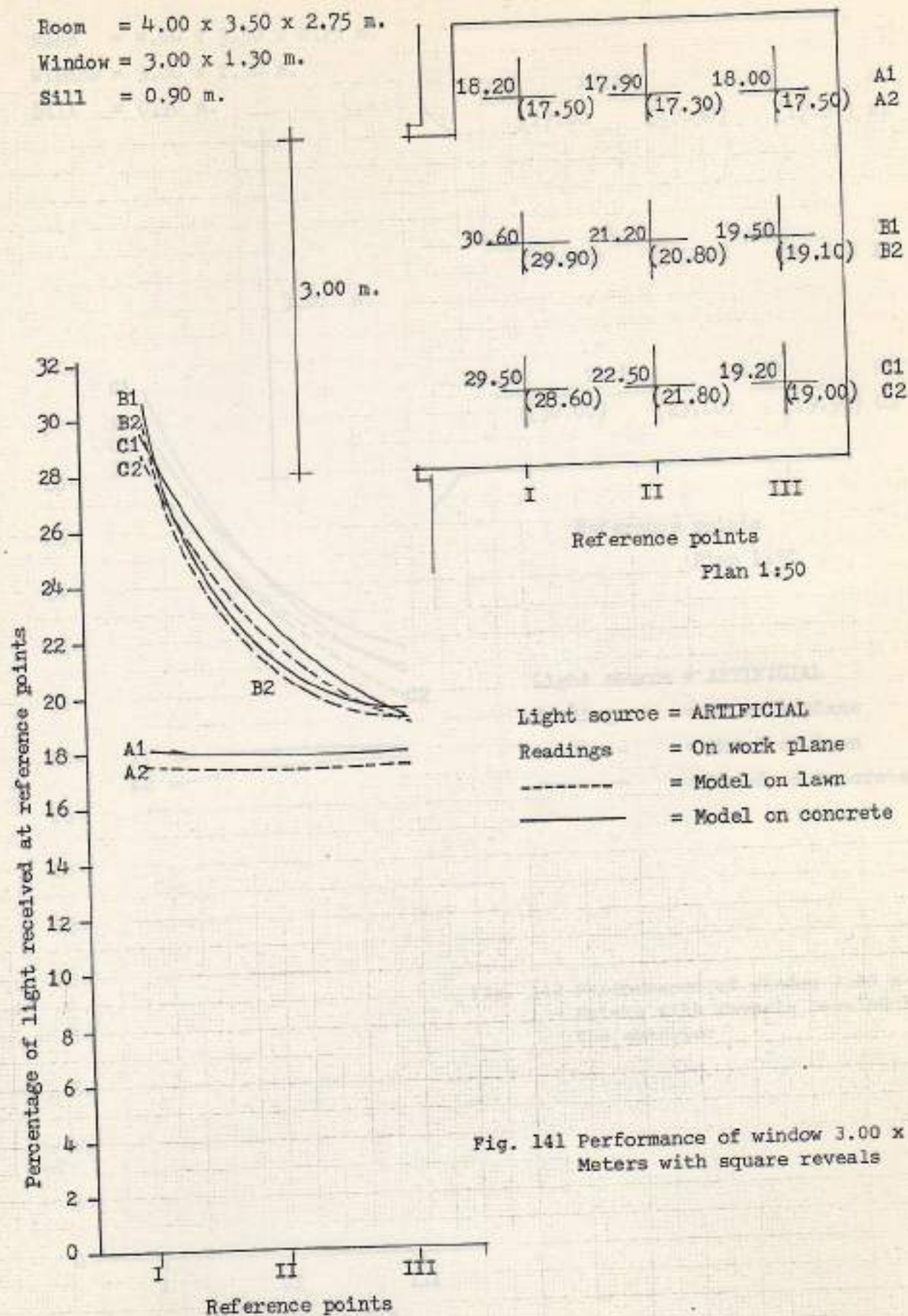

Fig. 141 Performance of window 3.00 x 1.30 Meters with square reveals

Room = 4.00 x 3.50 x 2.75 m.

Window = 3.00 x 1.30 m.

Sill = 0.90 m.

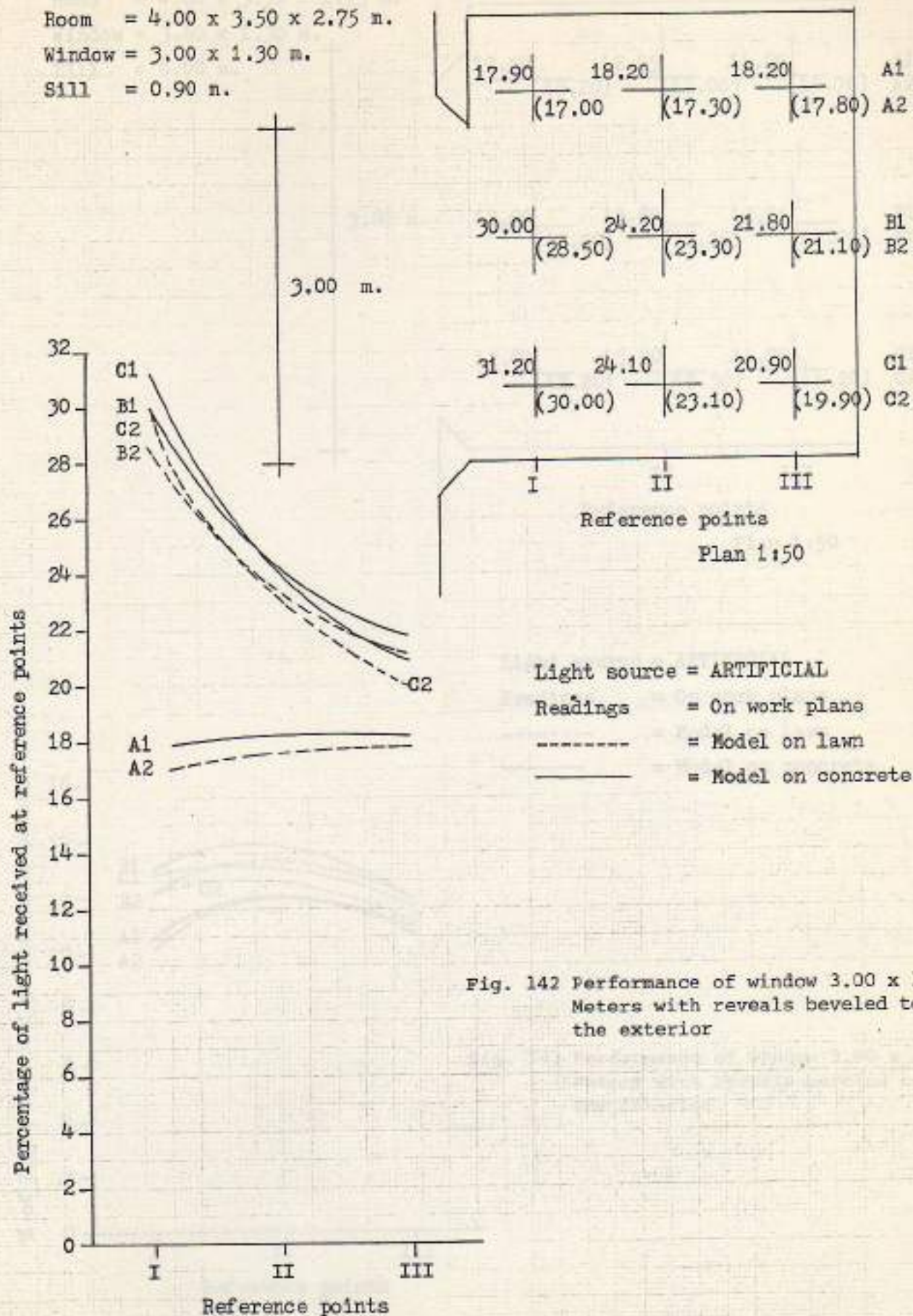
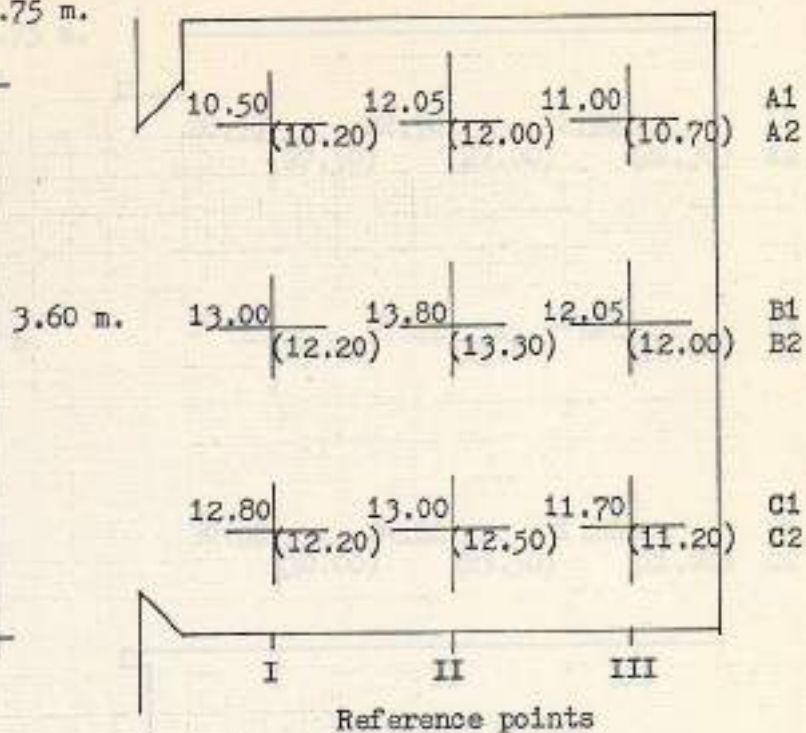

Fig. 142 Performance of window 3.00 x 1.30 Meters with reveals beveled to the exterior

Room = 4.00 x 3.50 x 2.75 m.

Window = 3.60 x 1.30 m.

Sill = 0.90 m.



Plan 1:50

Light source = ARTIFICIAL

Readings = On work plane

----- = Model on lawn

———— = Model on concrete

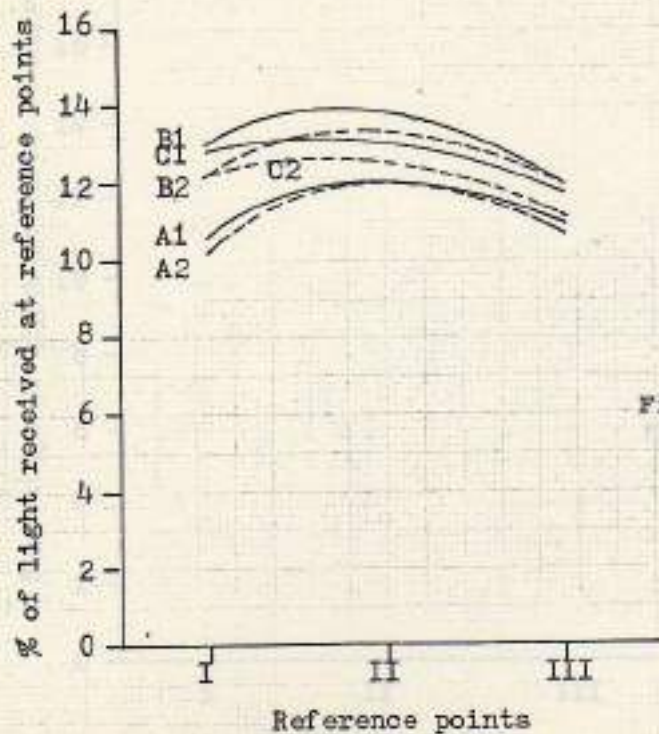
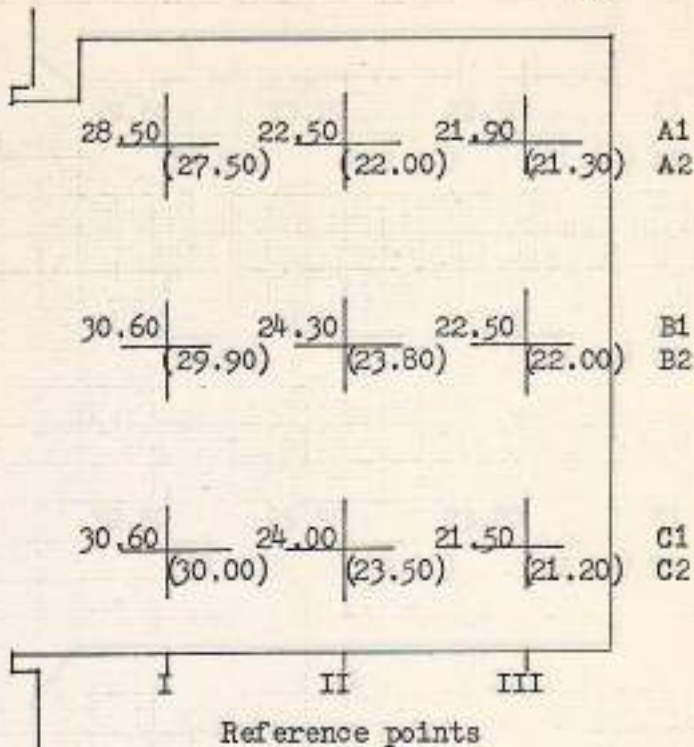
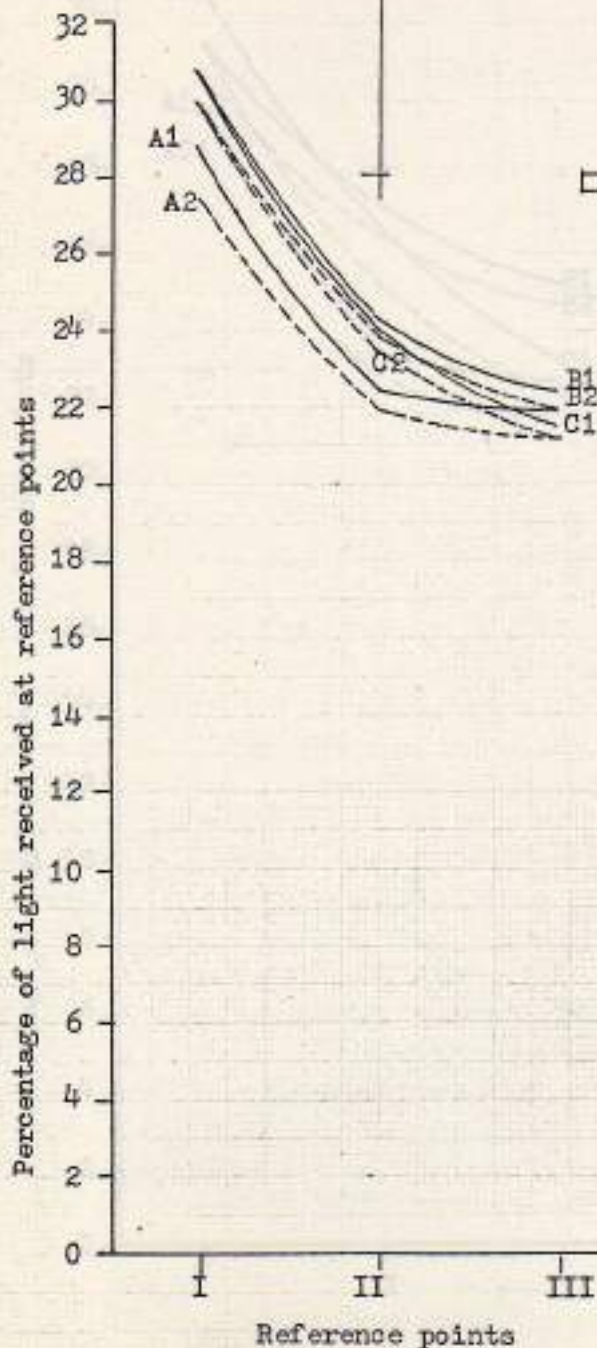

Fig. 143 Performance of window 3.60 x 1.30 Meters with reveals beveled to the interior

Room = 4.00 x 3.50 x 2.75 m.
 Window = 3.60 x 1.30 m.
 Sill 0.90 m.



Plan 1:50



Light source = ARTIFICIAL
 Readings = On work plane
 ----- = Model on lawn
 _____ = Model on concrete

Fig. 144 Performance of window 3.60 x 1.30 Meters having square reveals

Room = 4.00 x 3.50 x 2.75 m.

Window = 3.60 x 1.30 m.

Sill = 0.90 m.

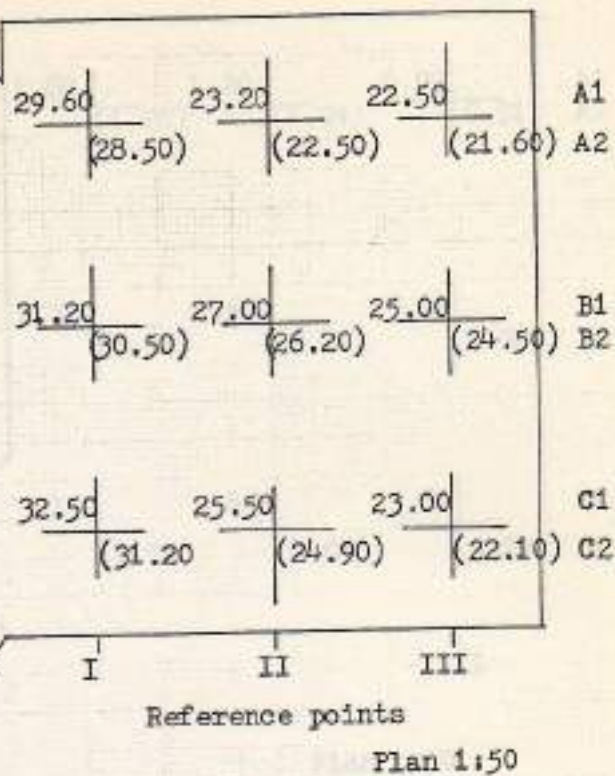
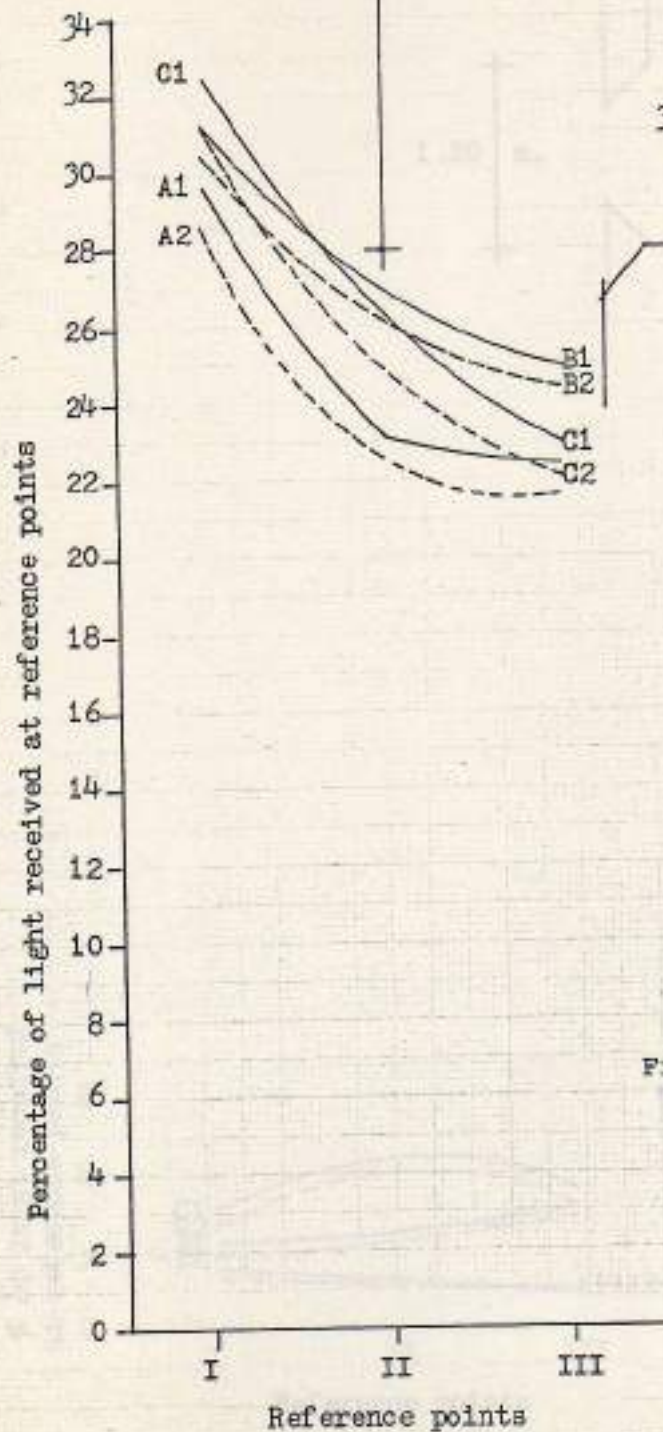

Light source = ARTIFICIAL

Readings = On work plane

----- = Model on lawn

————— = Model on concrete

Fig. 145 Performance of window 3.60 x 1.30 Meters with reveals beveled to the exterior

Room = 4.00 x 3.50 x 2.75 m.

Window = 1.20 x 1.30 m.

Sill = 0.90 m.

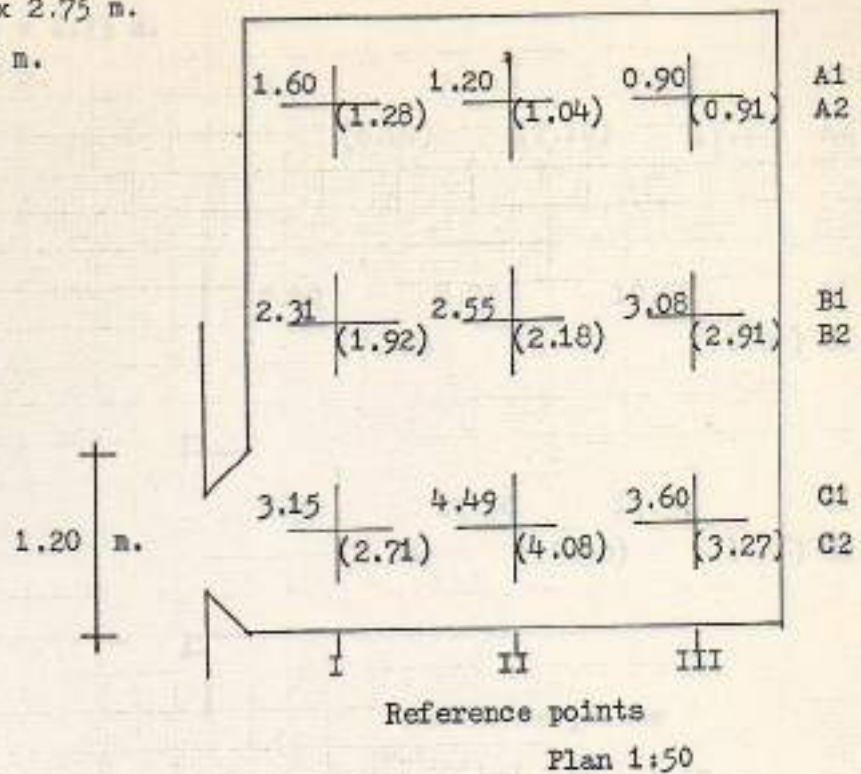

Light source = NATURAL

----- = Model on lawn

————— = Model on concrete

Readings = On floor level

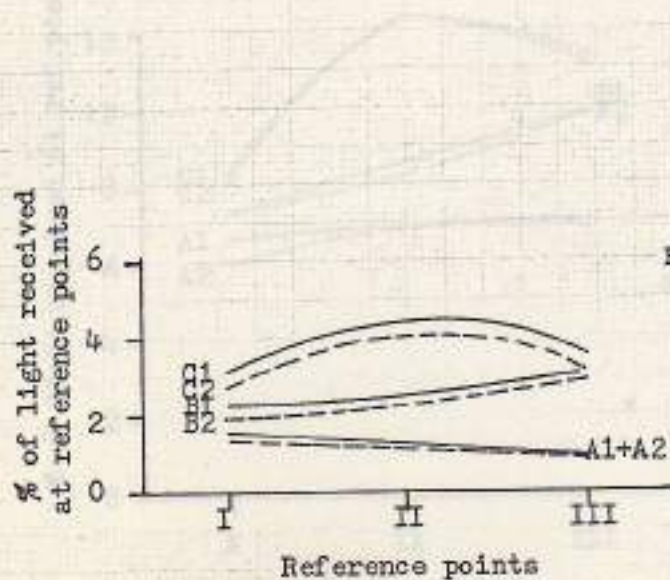

Fig. 146 Performance of window 1.20 x 1.30 Meters with reveals beveled to the interior

Room = 4.00 x 3.50 x 2.75 m.

Window = 1.20 x 1.30 m.

Sill = 0.90 m.

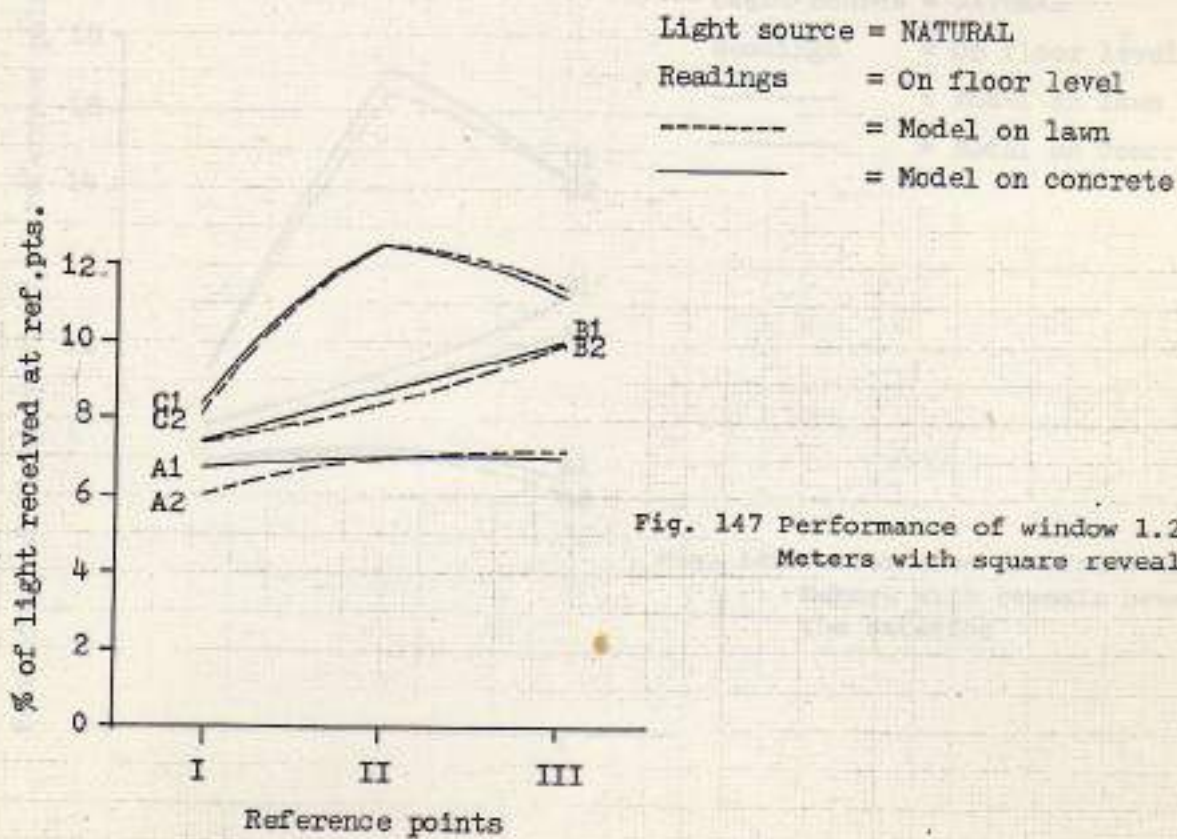
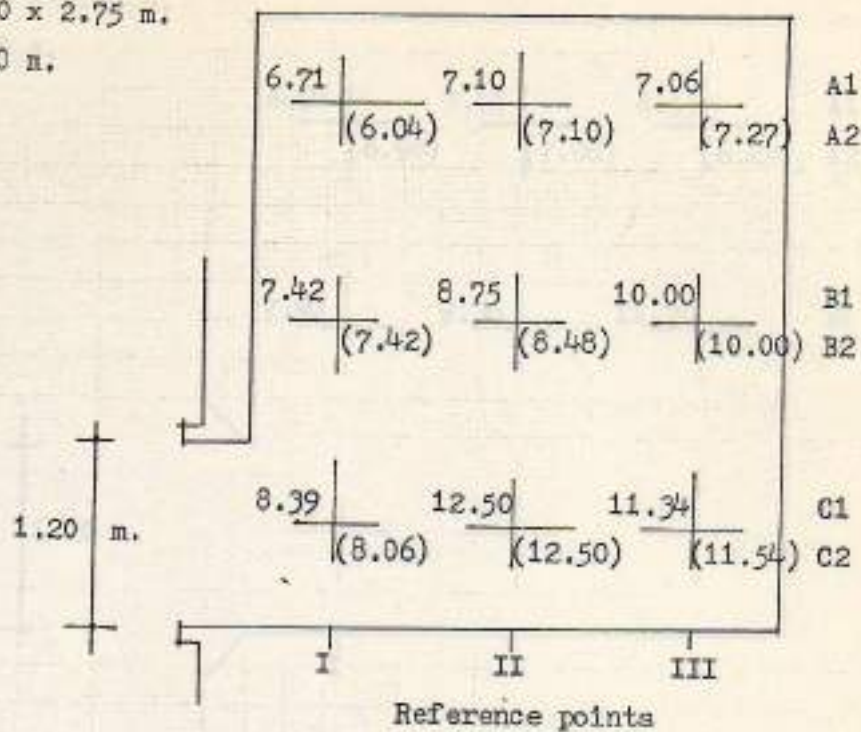

Fig. 147 Performance of window 1.20 x 1.30 Meters with square reveals

Room = 4.00 x 3.50 x 2.75 m.

Window = 1.20 x 1.30 m.

Sill = 0.90 m.

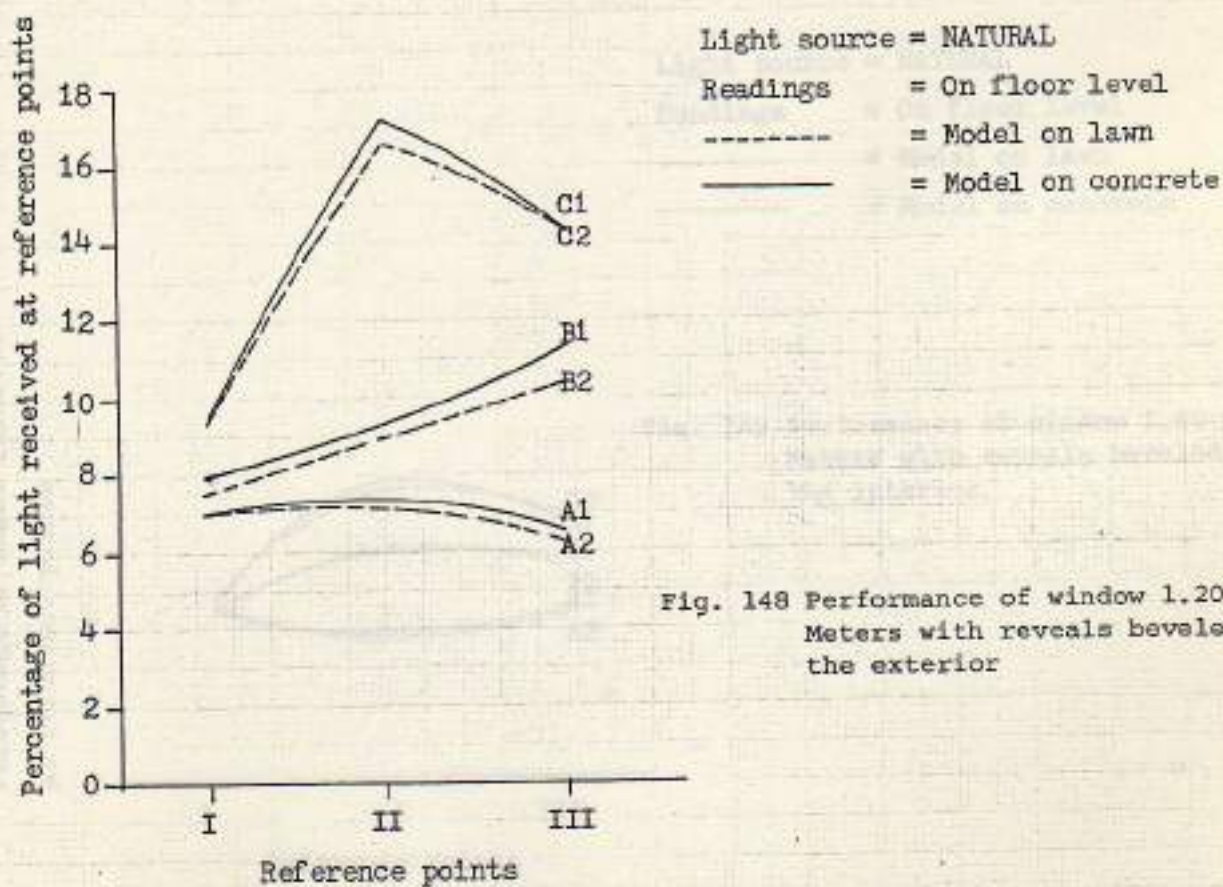
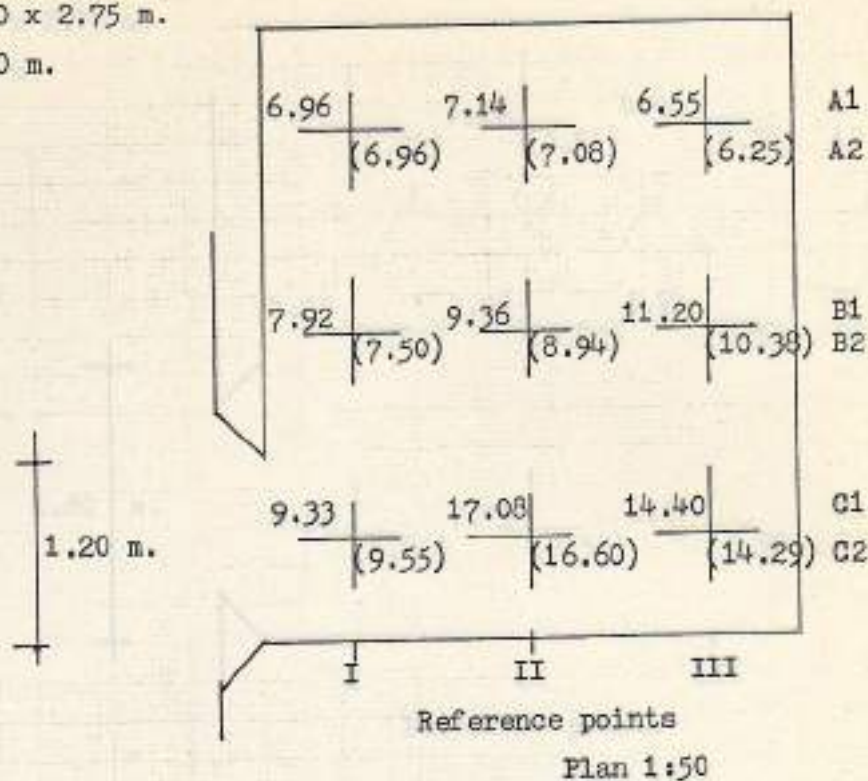
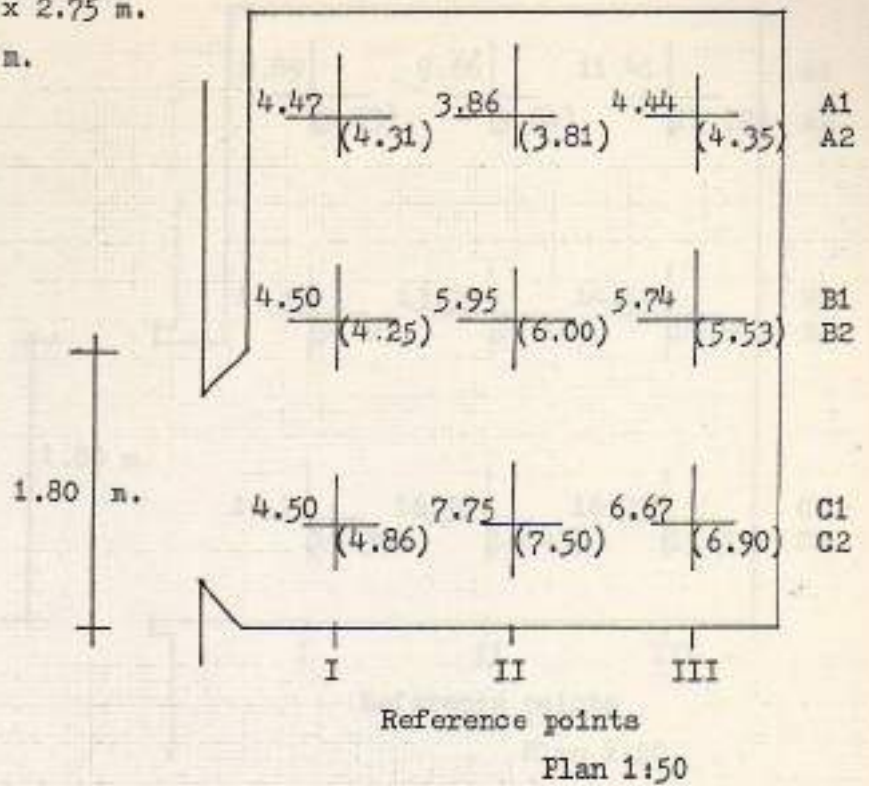

Fig. 148 Performance of window 1.20 x 1.30 Meters with reveals beveled to the exterior

Room = 4.00 x 3.50 x 2.75 m.

Window = 1.80 x 1.30 m.

Sill = 0.90 m.



Light source = NATURAL

Readings = On floor level

----- = Model on lawn

————— = Model on concrete

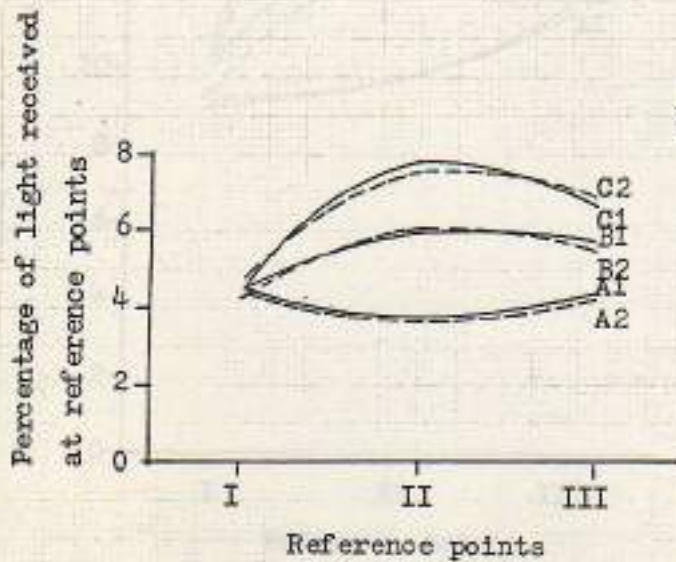

Fig. 149 Performance of window 1.80 x 1.30 Meters with reveals beveled to the interior

Room = 4.00 x 3.50 x 2.75 m.

Window = 1.80 x 1.30 m.

Sill = 0.90 m.

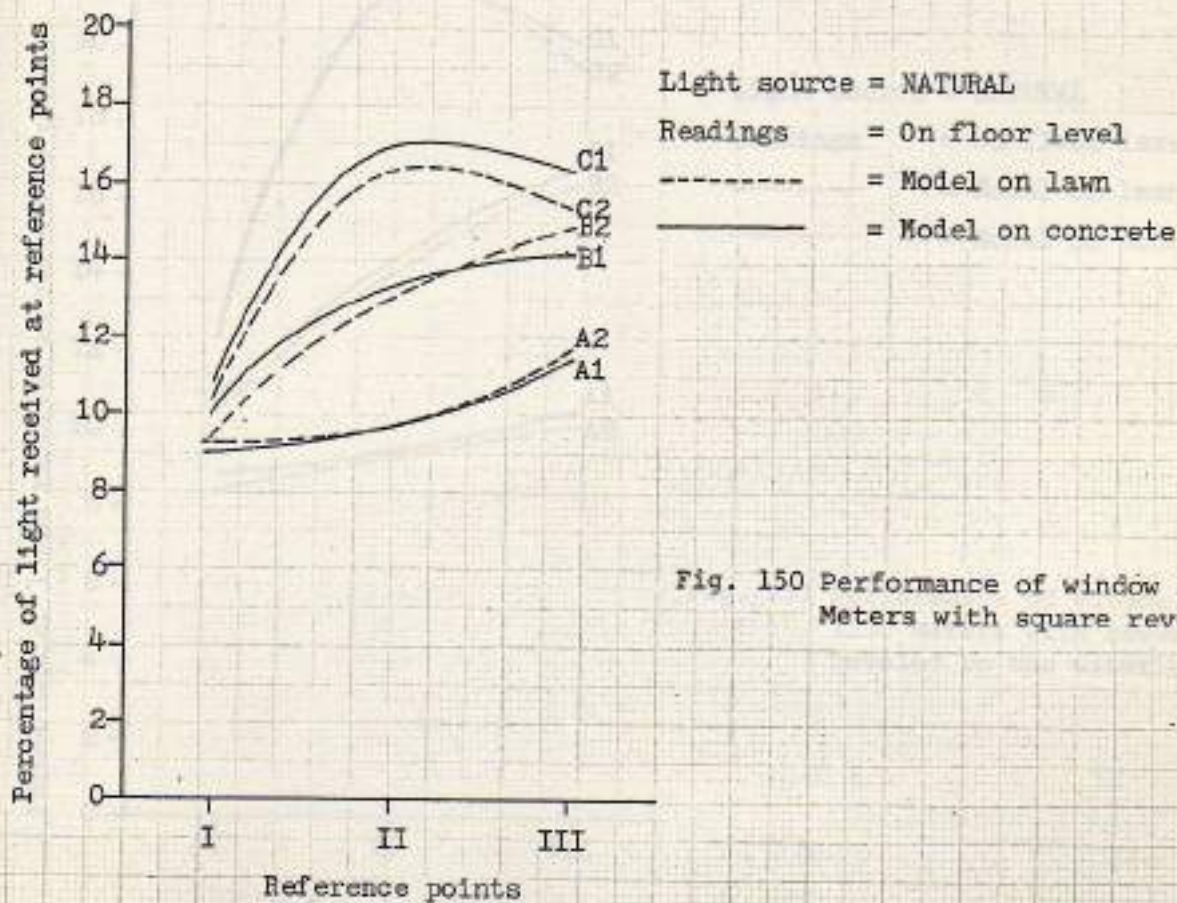
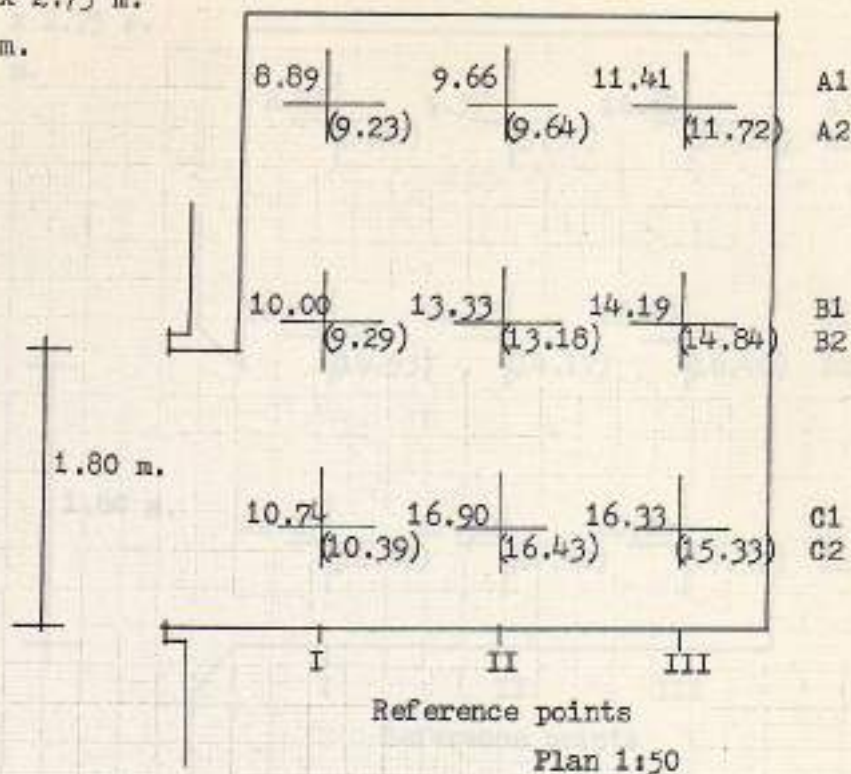

Fig. 150 Performance of window 1.80 x 1.30 Meters with square reveals

Room = 4.00 x 3.50 x 2.75 m.

Window = 1.80 x 1.30 m.

Sill = 0.90 m.

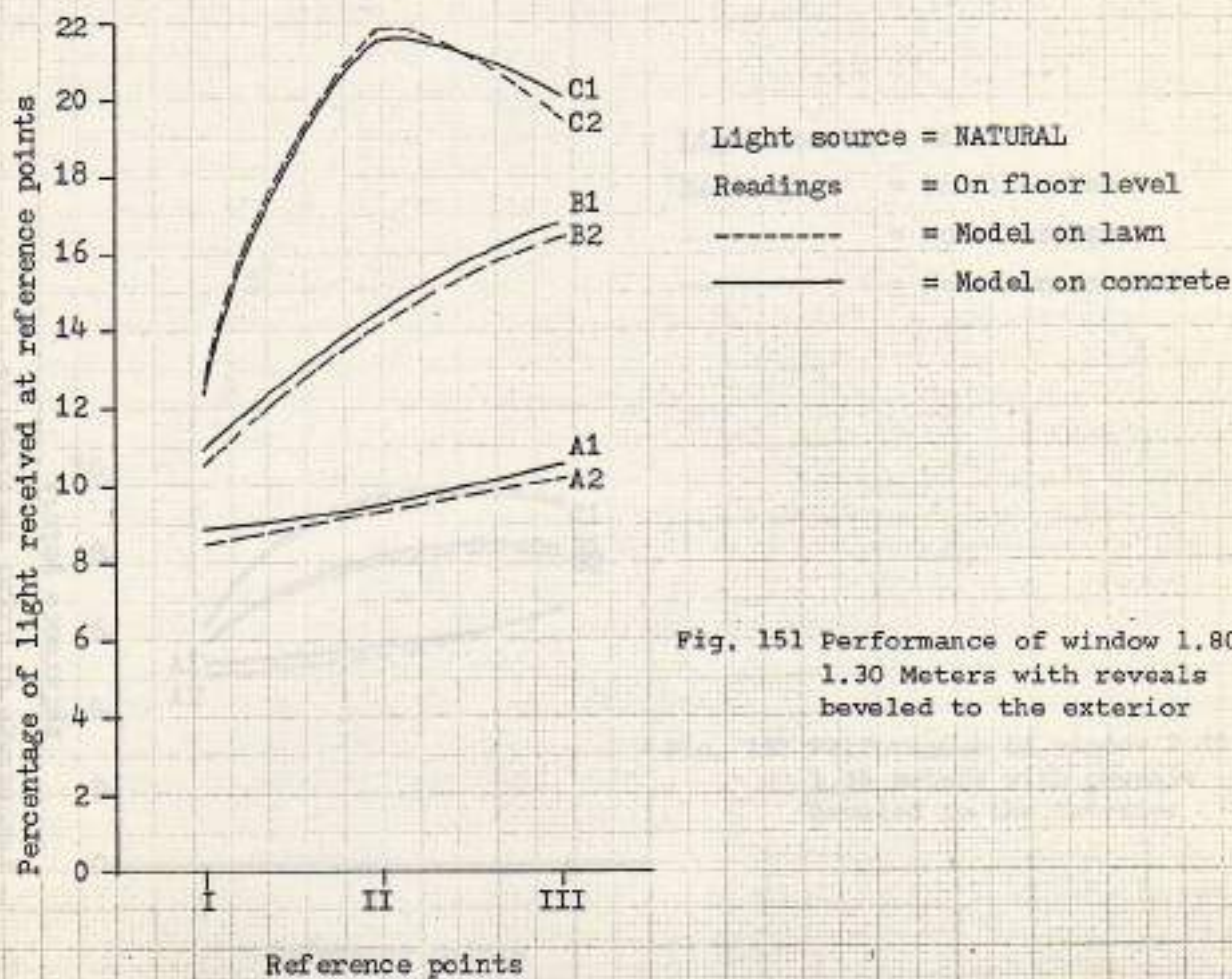
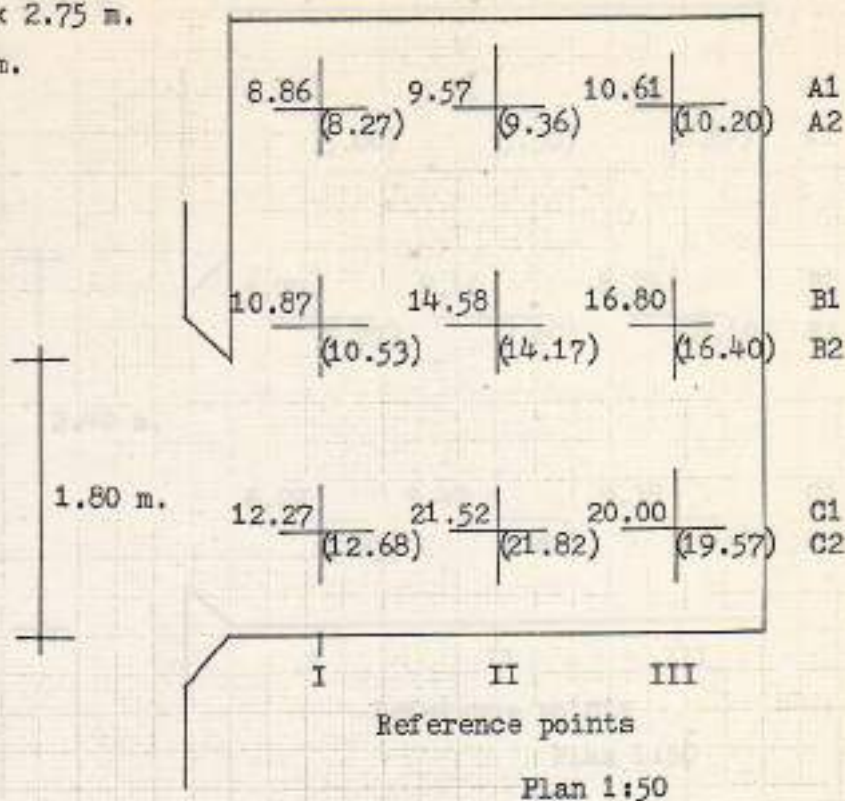
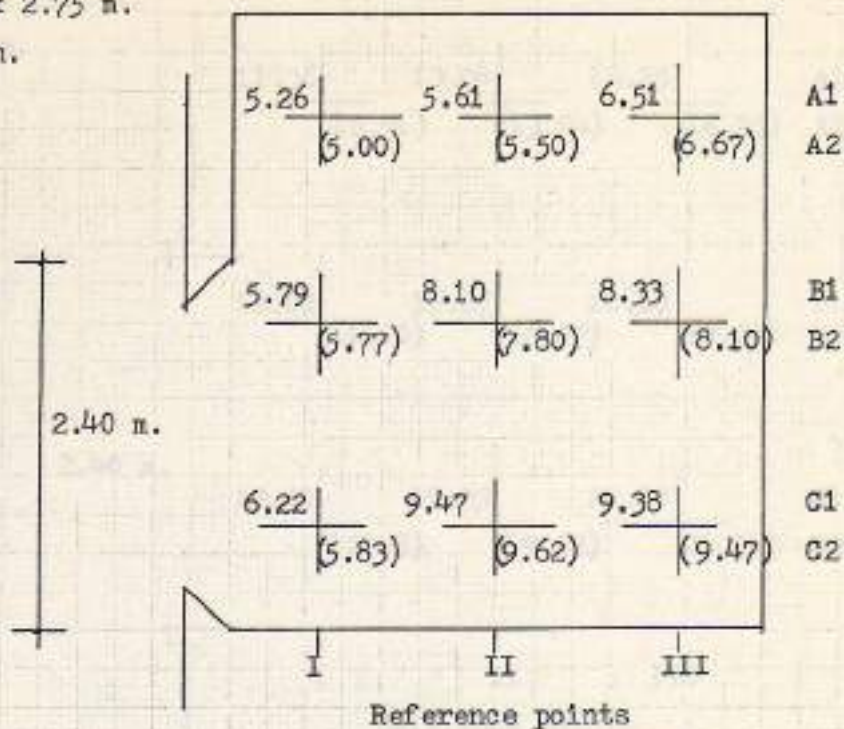

Fig. 151 Performance of window 1.80 x 1.30 Meters with reveals beveled to the exterior

Room = 4.00 x 3.50 x 2.75 m.

Window = 2.40 x 1.30 m.

Sill = 0.90 m.



Light source = NATURAL

Readings = On floor level

----- = Model on lawn

————— = Model on concrete

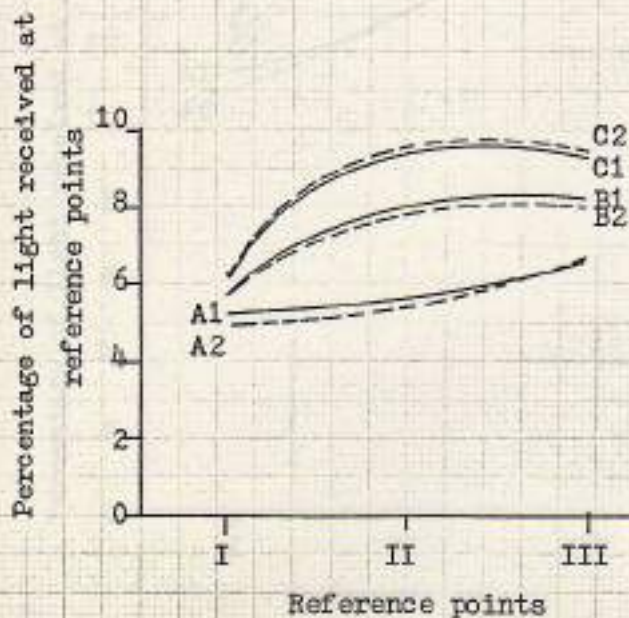

Fig. 152 Performance of window 2.40 x 1.30 Meters with reveals beveled to the interior

Room = 4.00 x 3.50 x 2.75 m.

Window = 2.40 x 1.30 m.

Sill = 0.90 m.

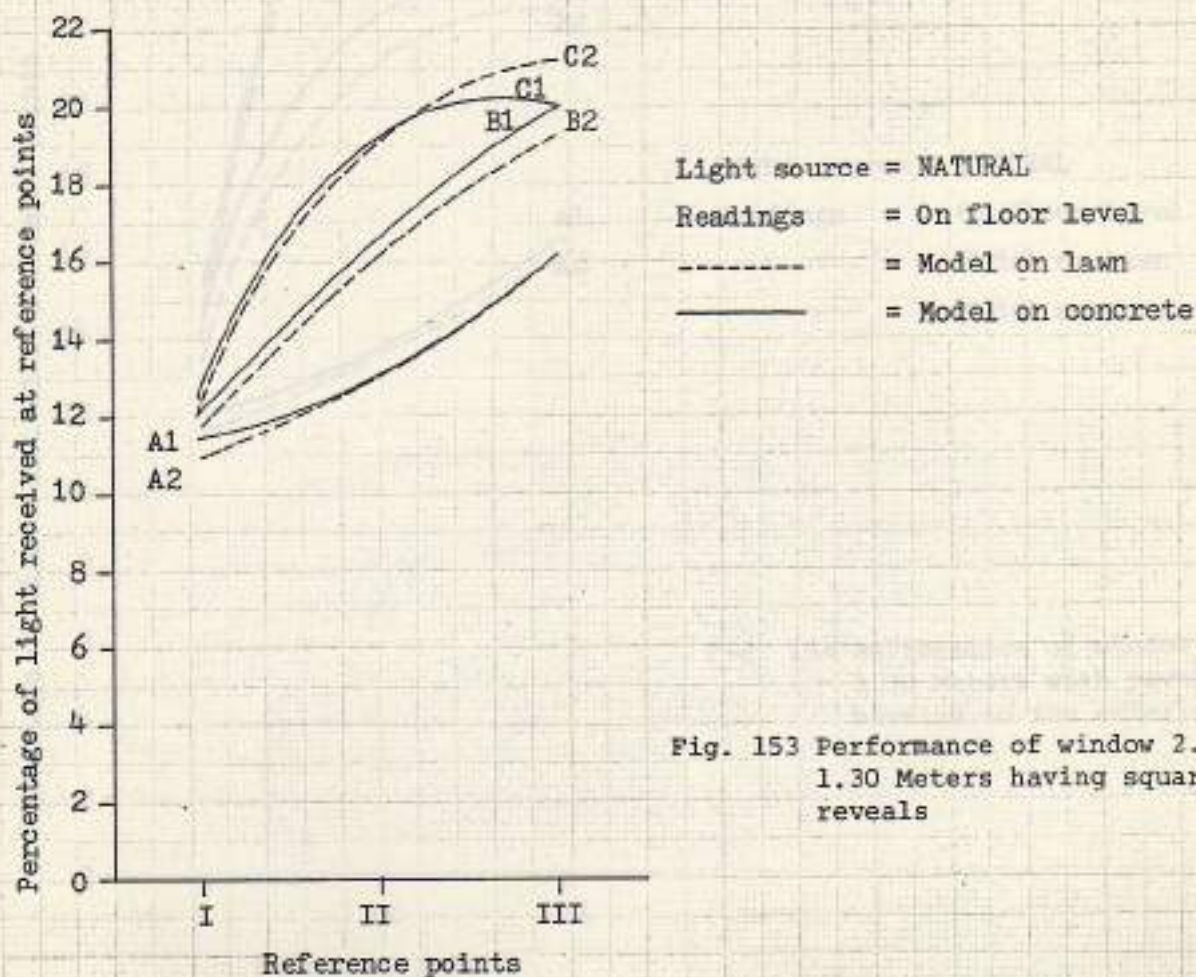
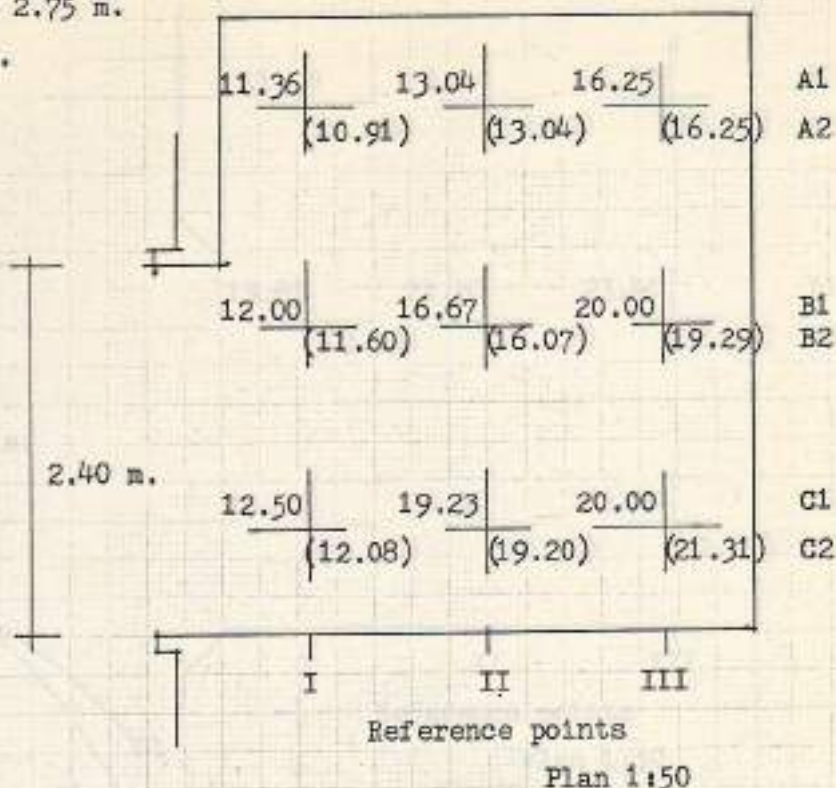
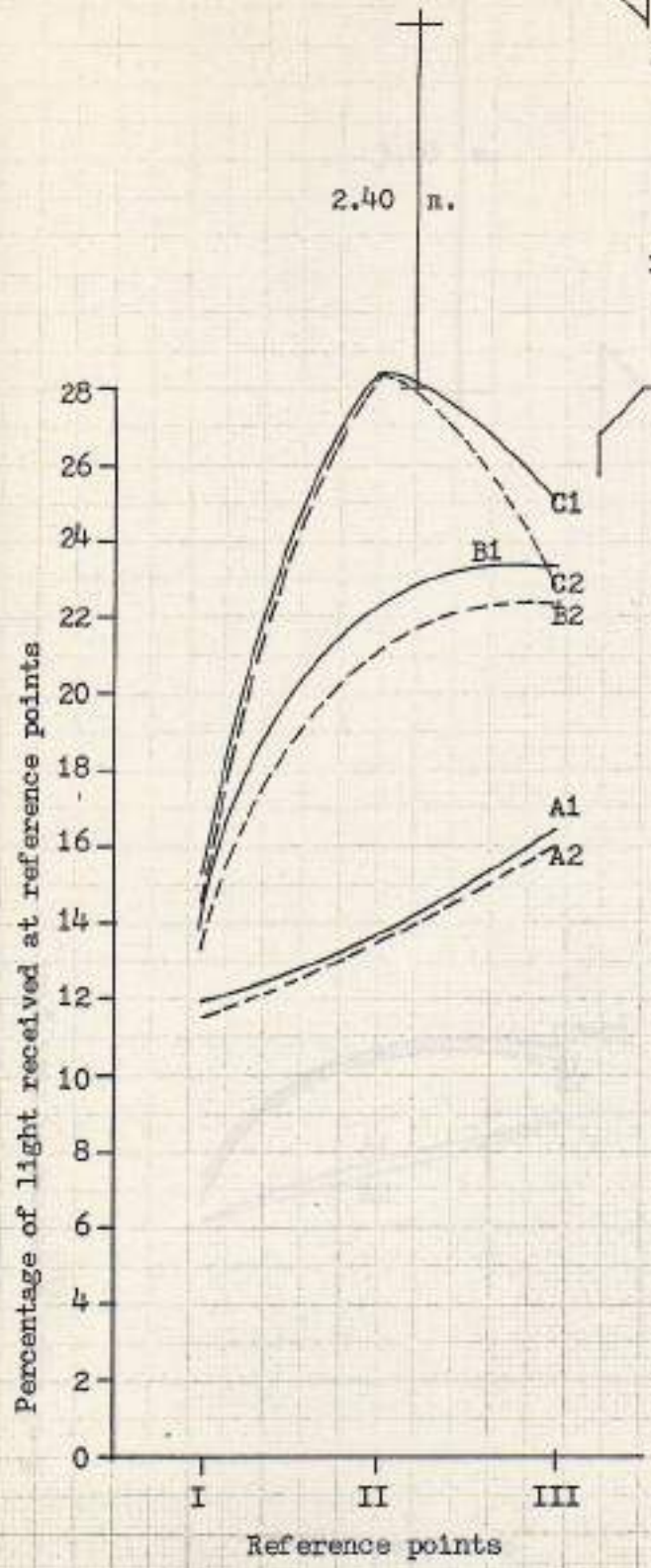
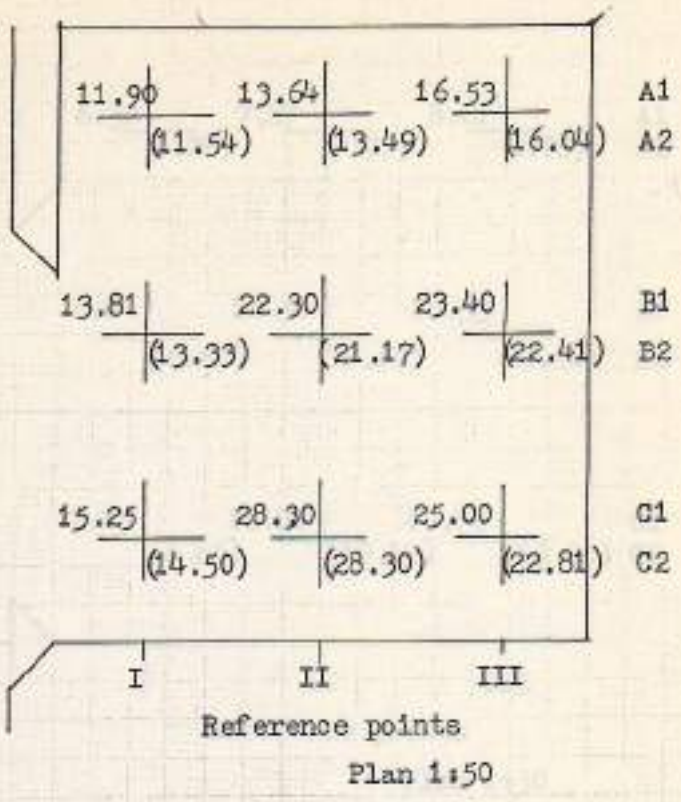

Fig. 153 Performance of window 2.40 x 1.30 Meters having square reveals

Room = 4.00 x 3.50 x 2.75 m.
 Window = 2.40 x 1.30 m.
 Sill = 0.90 m.



Light source = NATURAL
 Readings = On floor level
 ----- = Model on lawn
 _____ = Model on concrete

Fig. 154 Performance of window 2.40 x 1.30 Meters with reveals beveled to the exterior

Room = 4.00 x 3.50 x 2.75 m.

Window = 3.00 x 1.30 m.

Sill = 0.90 m.

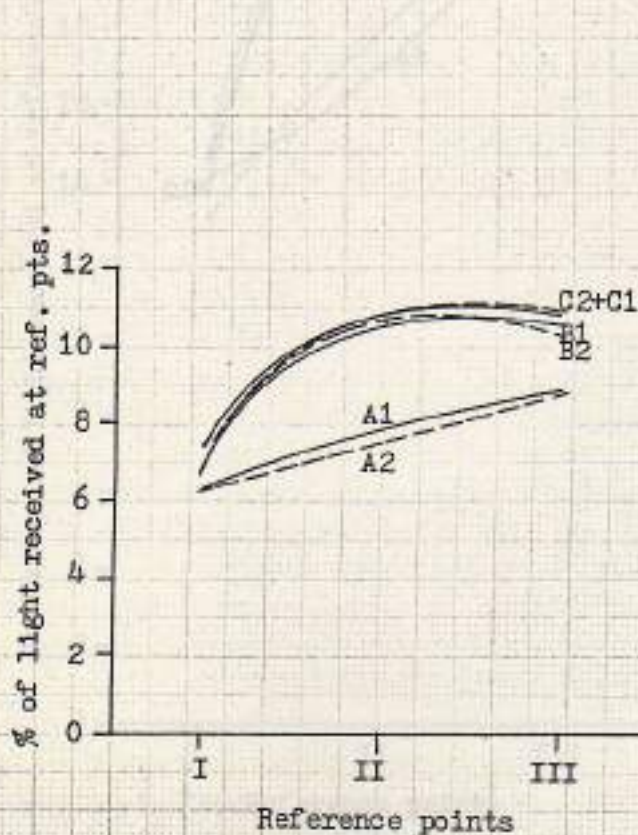
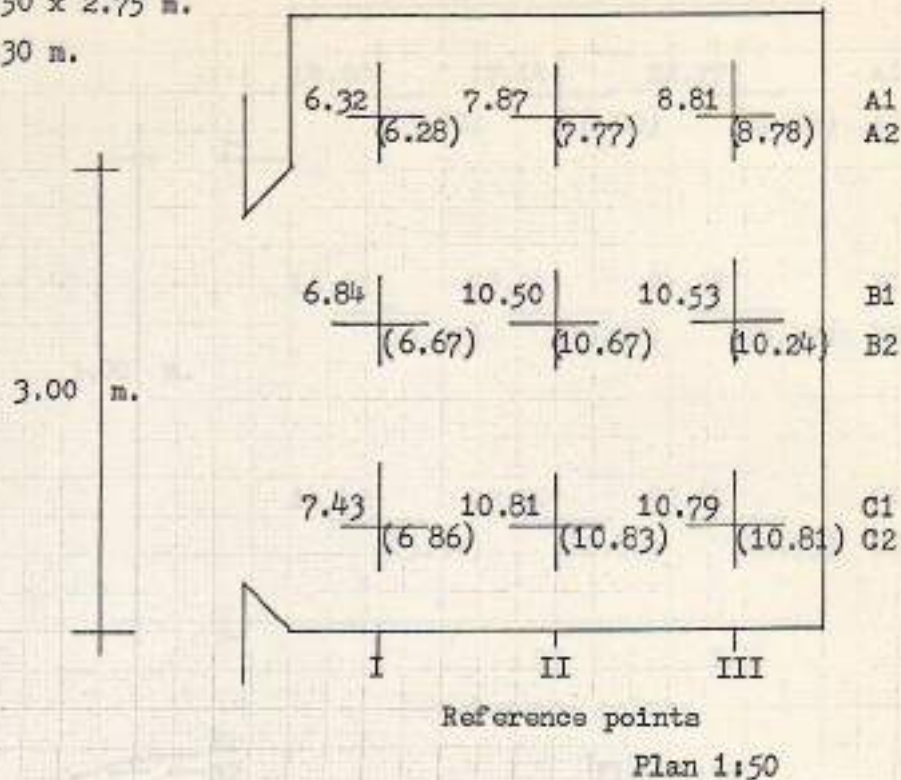

Fig. 155 Performance of window 3.00 x 1.30 Meters with reveals beveled to the interior

Room = 4.00 x 3.50 x 2.75 m.

Window = 3.00 x 1.30 m.

Sill = 0.90 m.

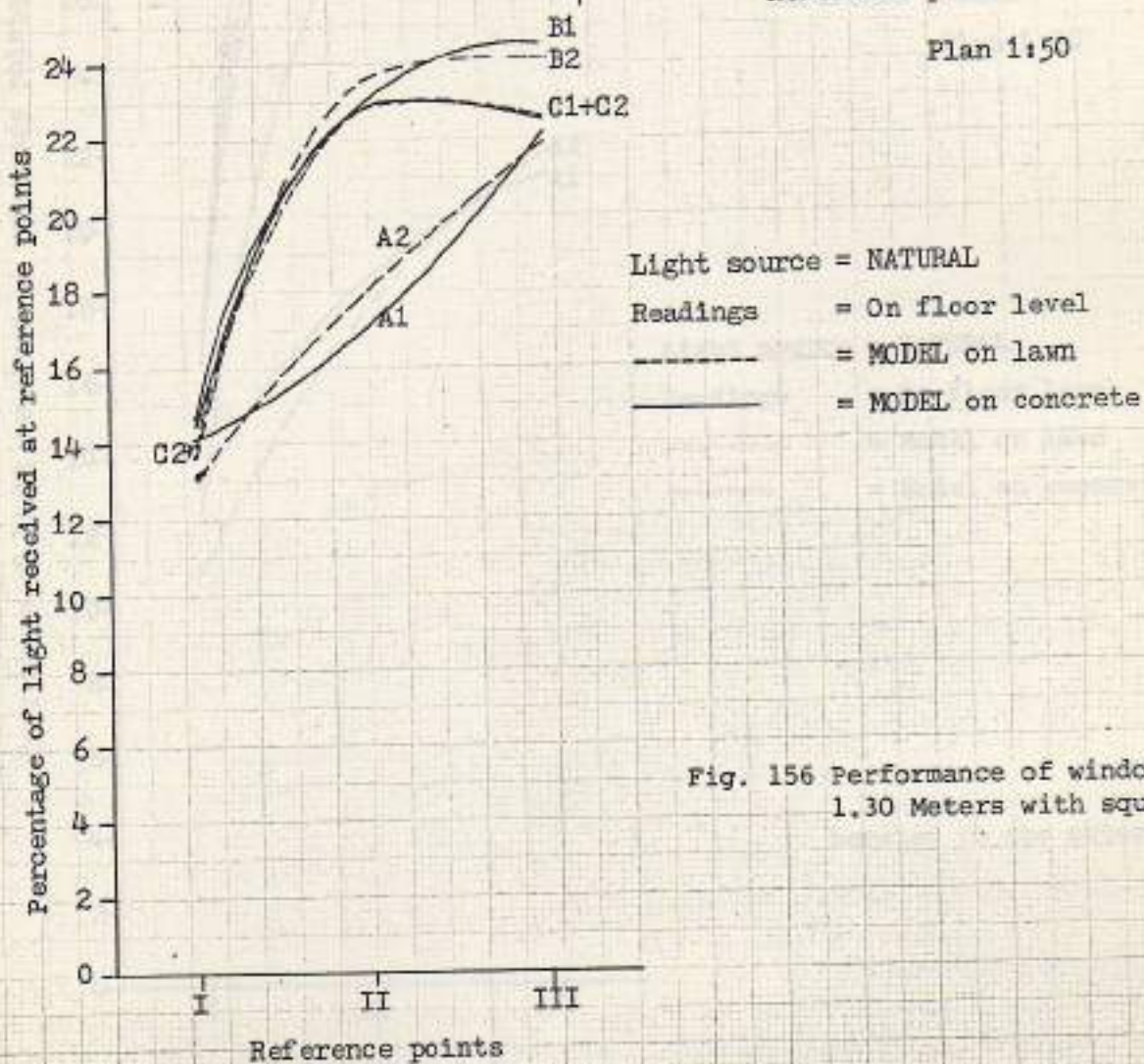
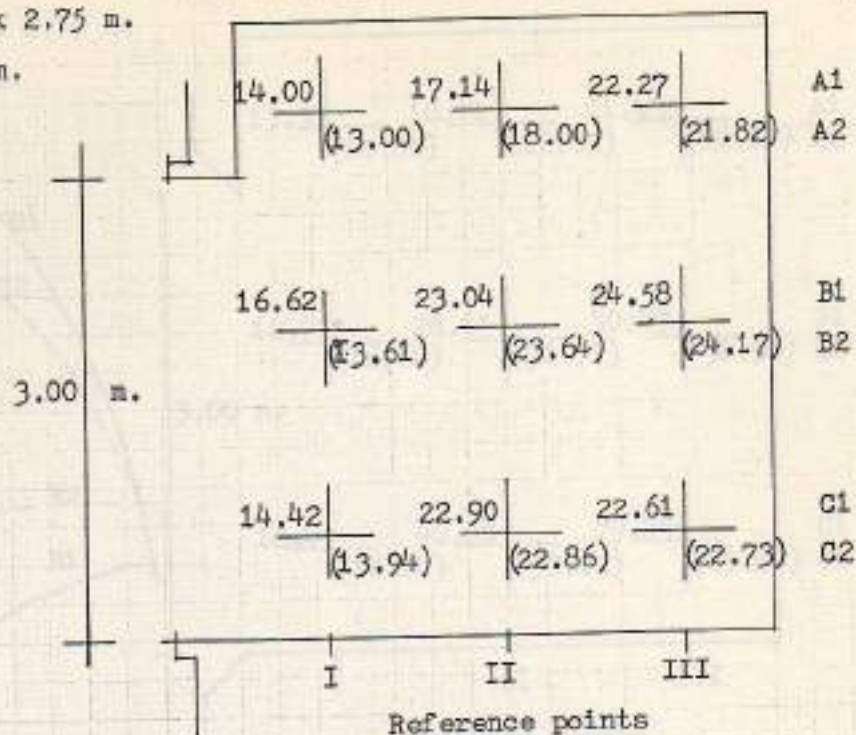

Fig. 156 Performance of window 3.00 x 1.30 Meters with square reveal

Room = 4.00 x 3.50 x 2.75 m.

Window = 3.00 x 1.39 m.

Sill = 0.90 m.

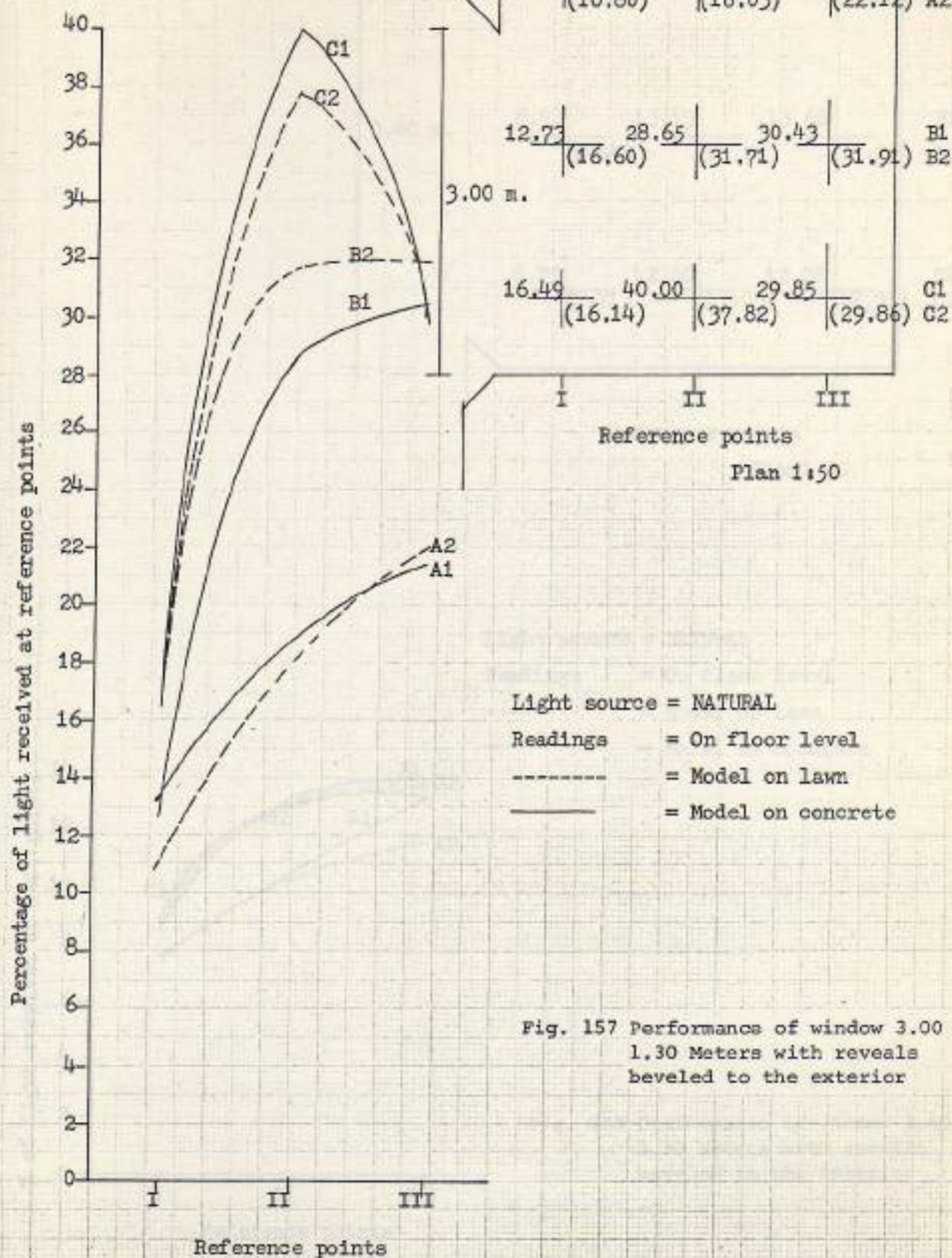
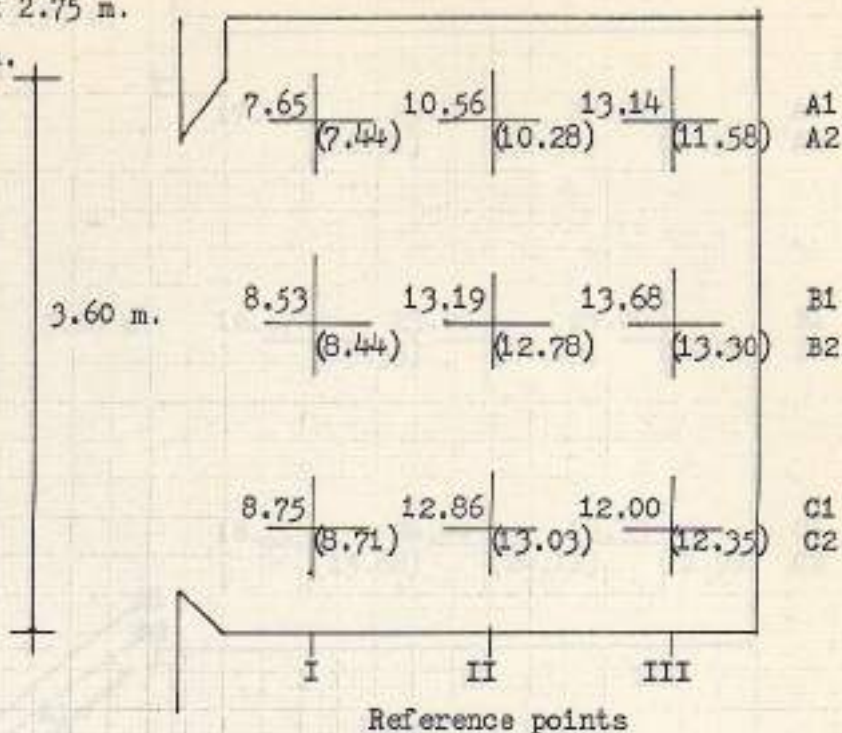

Fig. 157 Performances of window 3.00 x 1.30 Meters with reveals beveled to the exterior

Room = 4.00 x 3.50 x 2.75 m.

Window = 3.60 x 1.30 m.

Sill = 0.90 m.



Plan 1:50

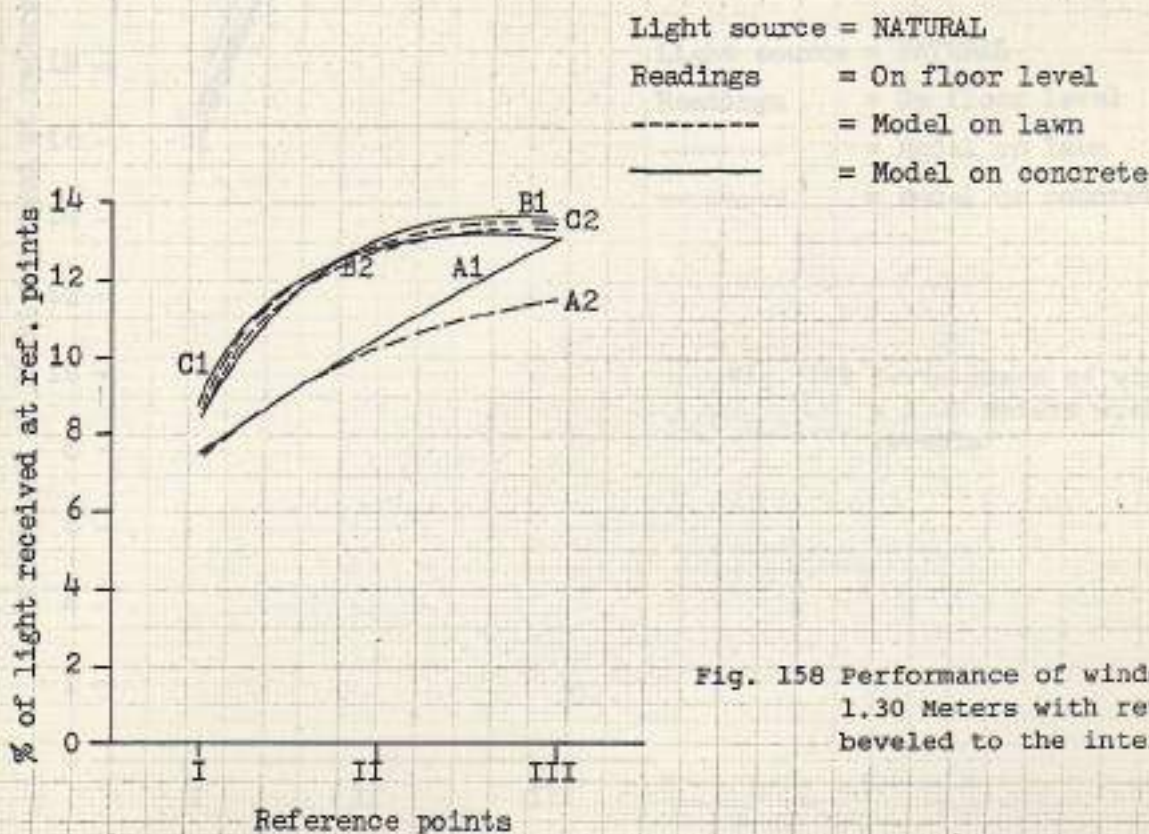
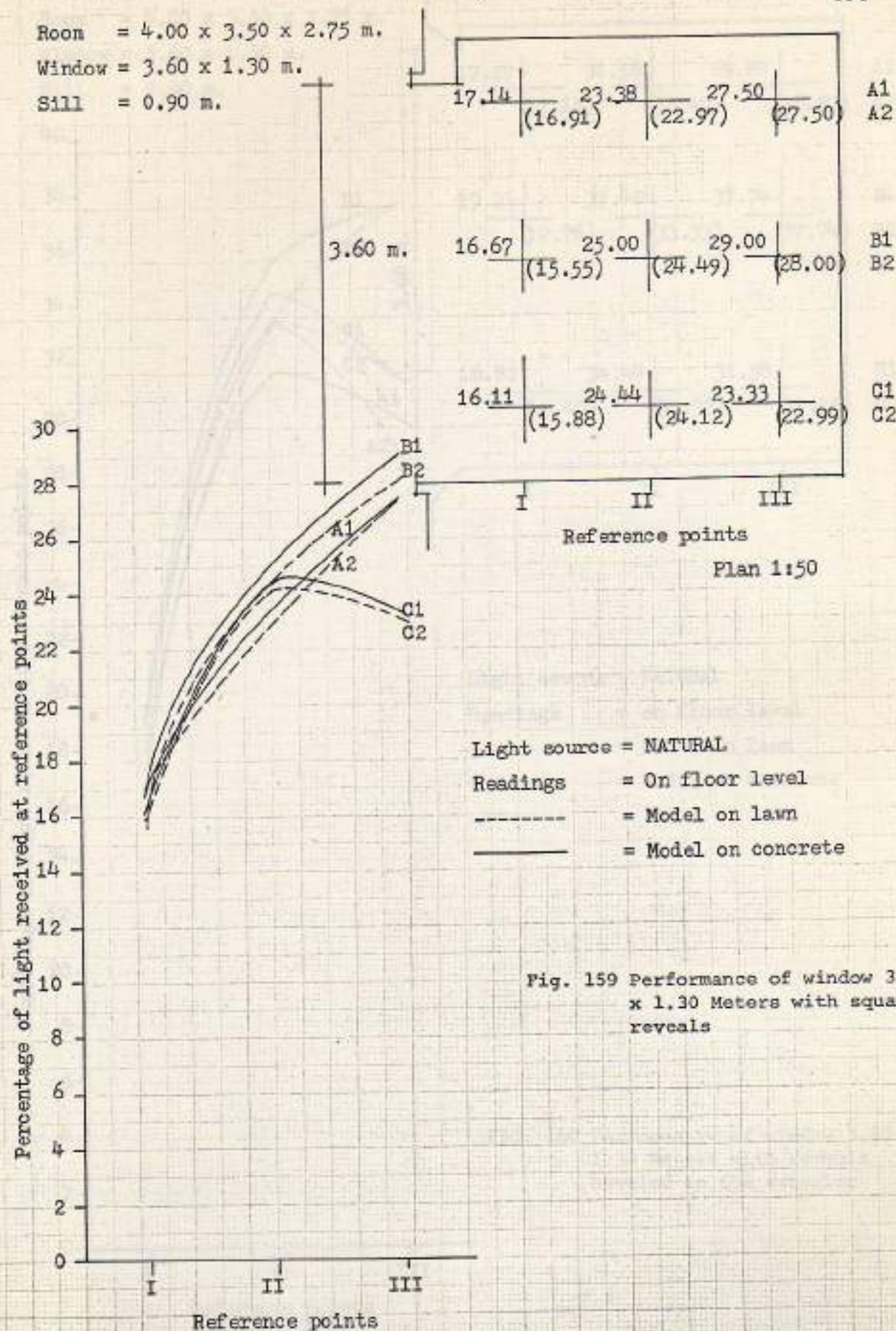

Fig. 158 Performance of window 3.60 x 1.30 Meters with reveals beveled to the interior

Room = 4.00 x 3.50 x 2.75 m.

Window = 3.60 x 1.30 m.

Sill = 0.90 m.



Room = 4.00 x 3.50 x 2.75 m.

Window = 3.60 x 1.30 m.

Sill = 0.90 m.

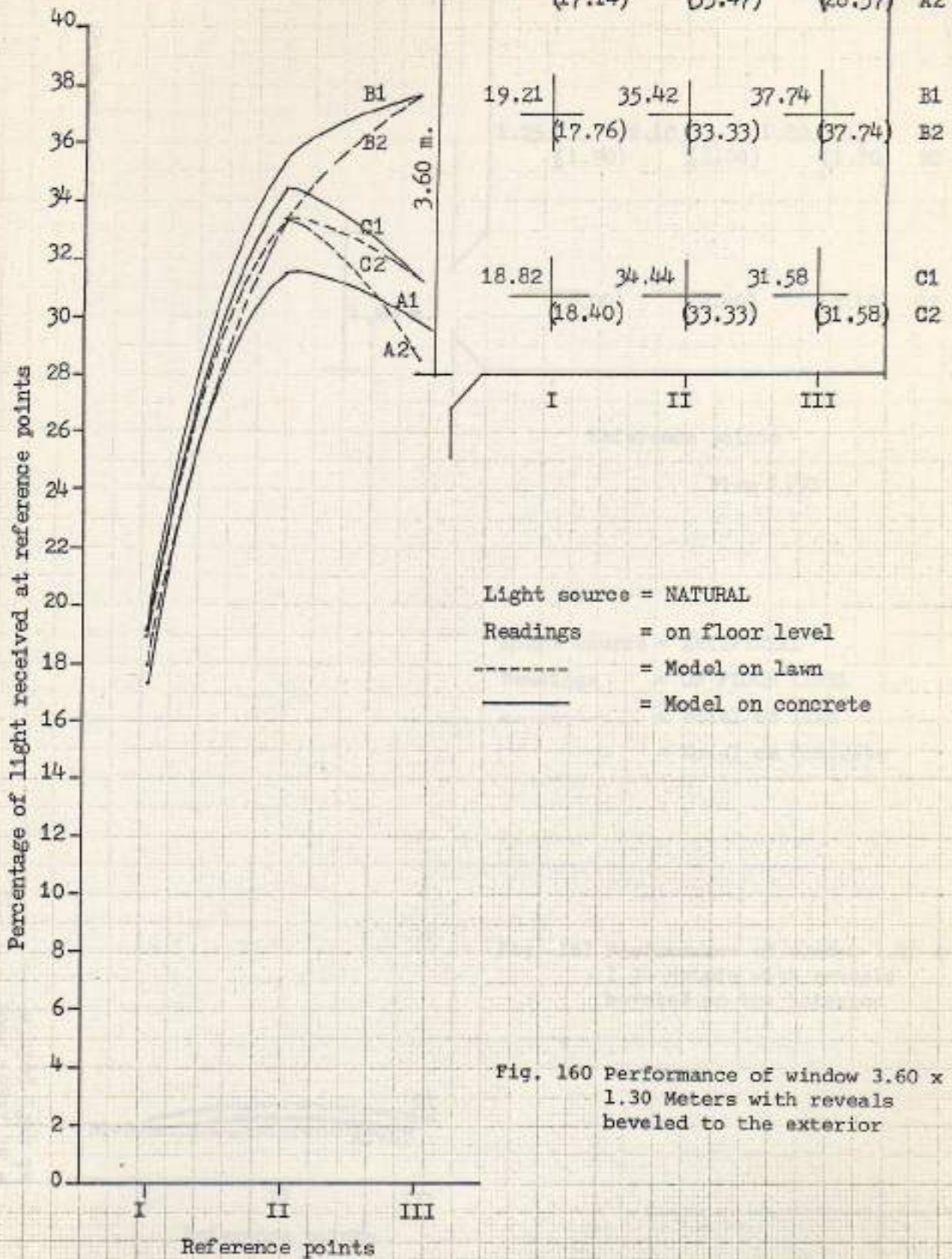
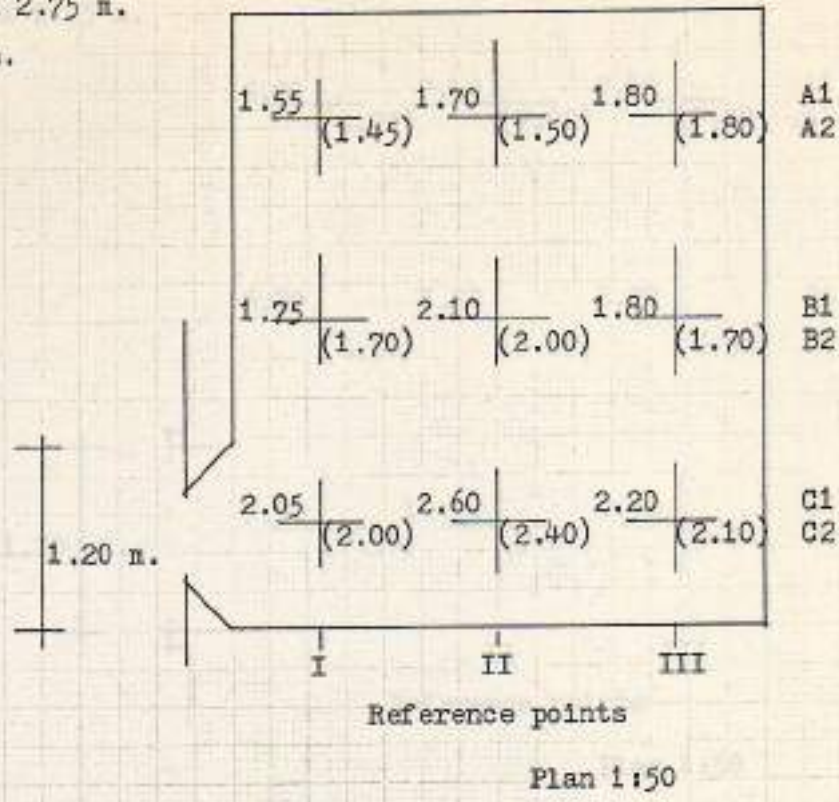

Fig. 160 Performance of window 3.60 x 1.30 Meters with reveals beveled to the exterior

Room = 4.00 x 3.50 x 2.75 m.
 Window = 1.20 x 1.30 m.
 Sill = 0.90 m.



Light source = ARTIFICIAL
 Readings = ON FLOOR LEVEL
 ----- = Model on lawn
 _____ = Model on concrete

Fig. 161 Performance of window 1.20 x 1.30 Meters with reveals beveled to the interior

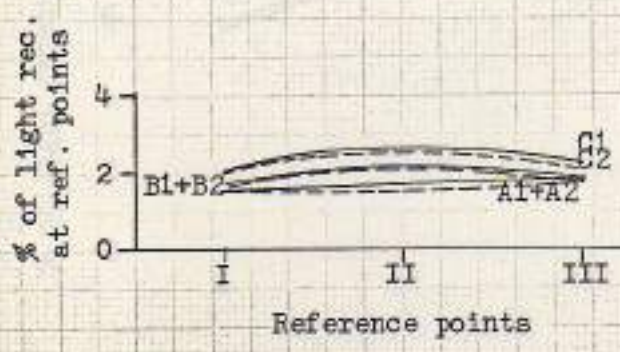

Room = 4.00 x 3.50 x 2.75 m.

Window = 1.20 x 1.30

Sill = 0.90 m.

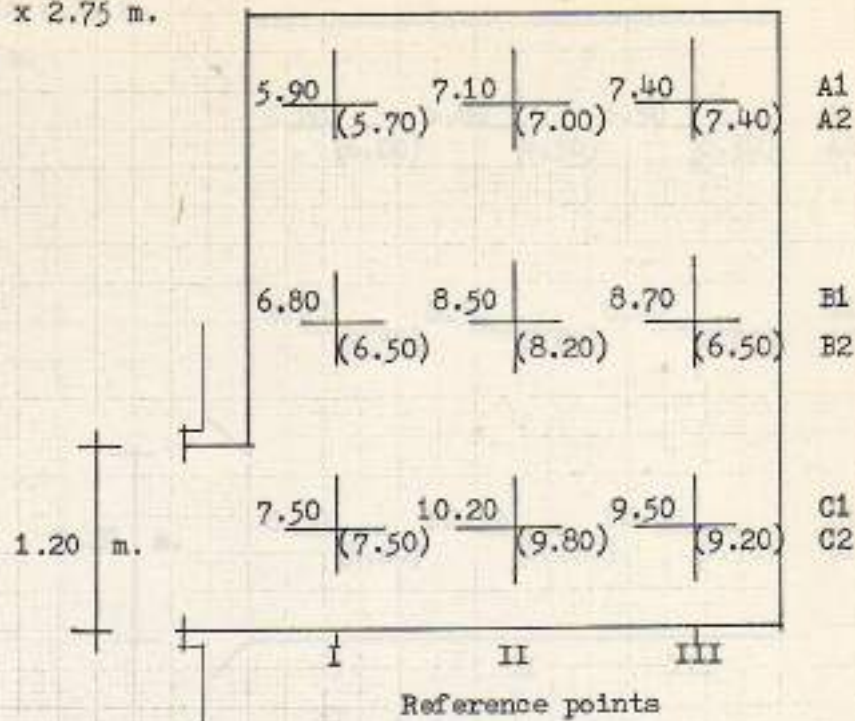

Light source = ARTIFICIAL

Readings = On floor level

----- = Model on lawn

———— = Model on concrete

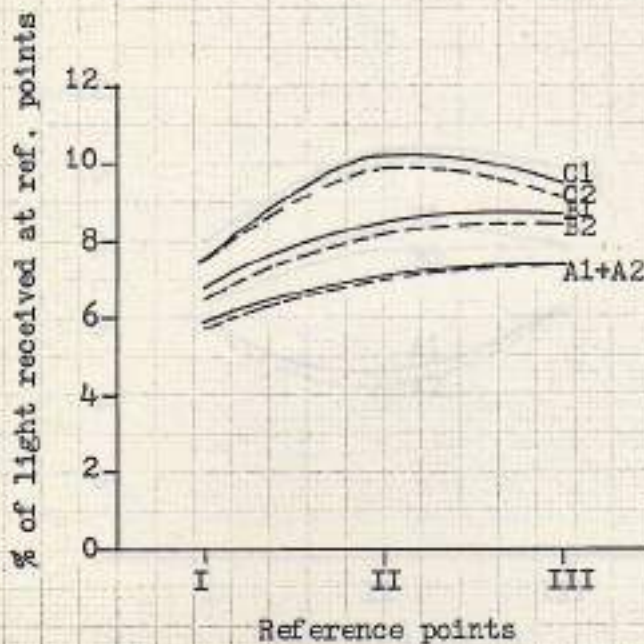
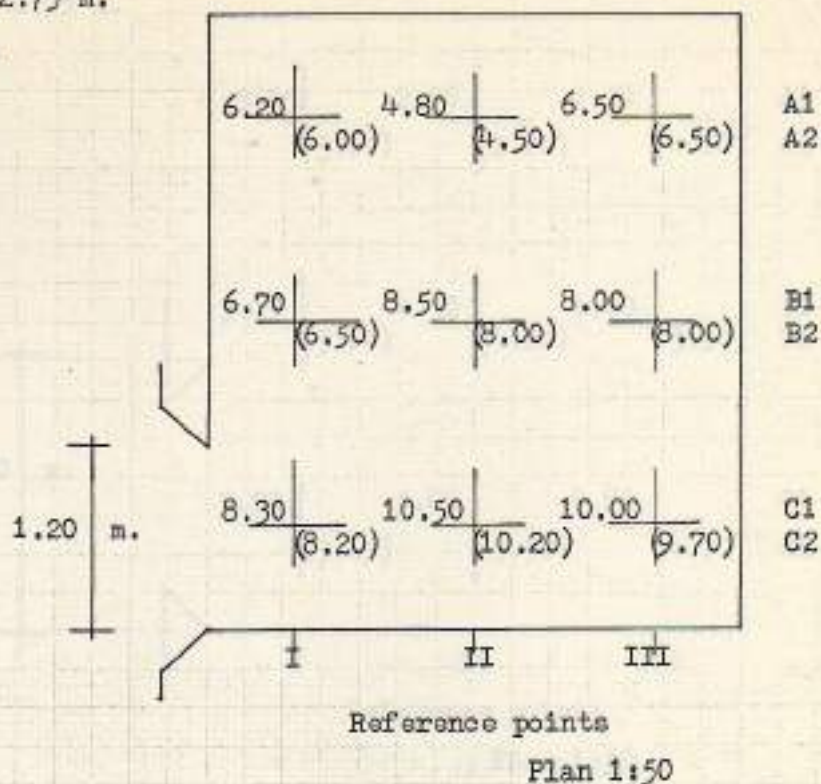

Fig. 162 Performance of window 1.20 x 1.30 Meters with square reveals

Room = 4.00 x 3.50 x 2.75 m.

Window = 1.20 x 1.30 m.

Sill = 0.90 m.



Light source = ARTIFICIAL

Readings = On floor level

----- = Model on lawn

————— = Model on concrete

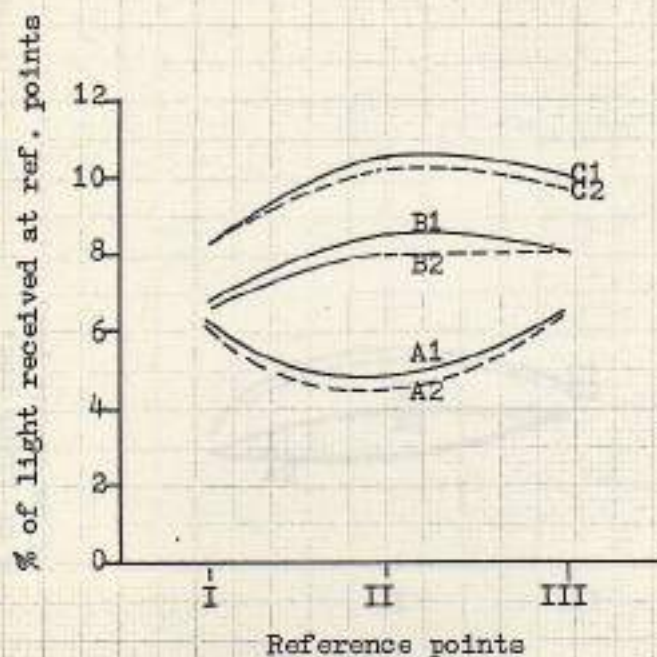
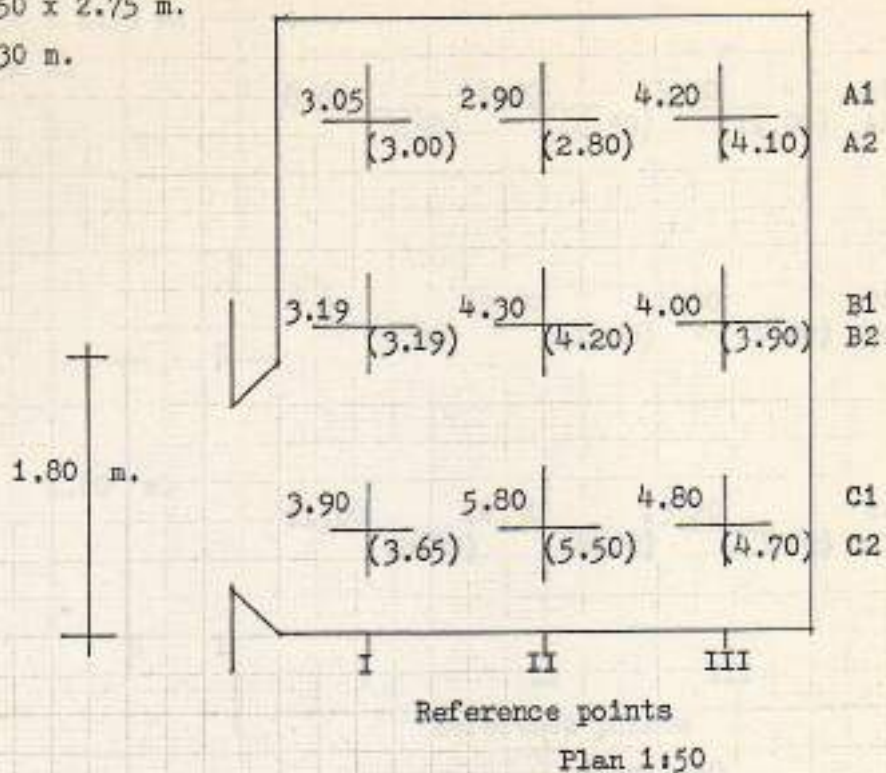

Fig. 163 Performance of window 1.20 x 1.30 Meters with reveals beveled to the exterior

Room = 4.00 x 3.50 x 2.75 m.

Window = 1.80 x 1.30 m.

Sill = 0.90 m.



Light source = ARTIFICIAL

Readings = On floor level

----- = Model on lawn

————— = Model on concrete

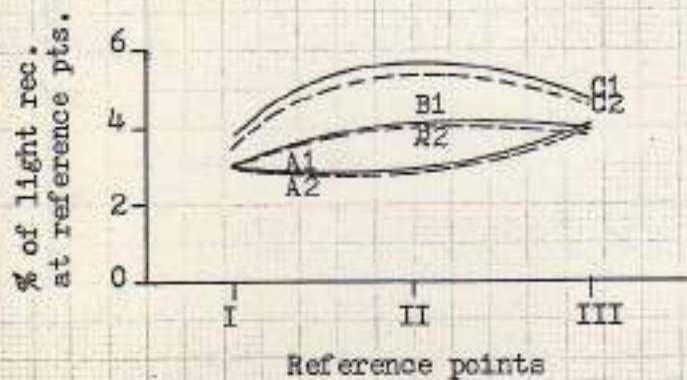

Fig. 164 Performance of window 1.80 x 1.30 Meters with reveals beveled to the interior

Room = 4.00 x 3.50 x 2.75 m.

Window = 1.80 x 1.30 m.

Sill = 0.90 m.

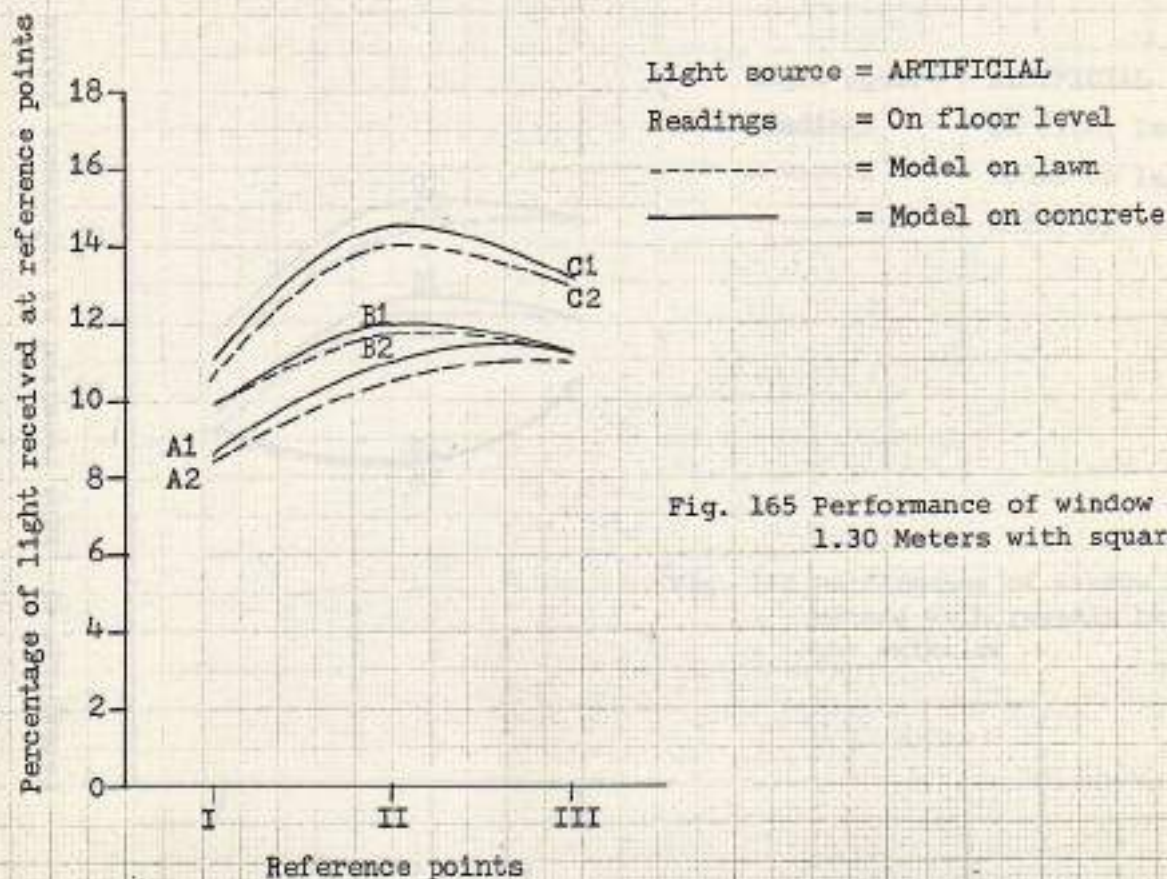
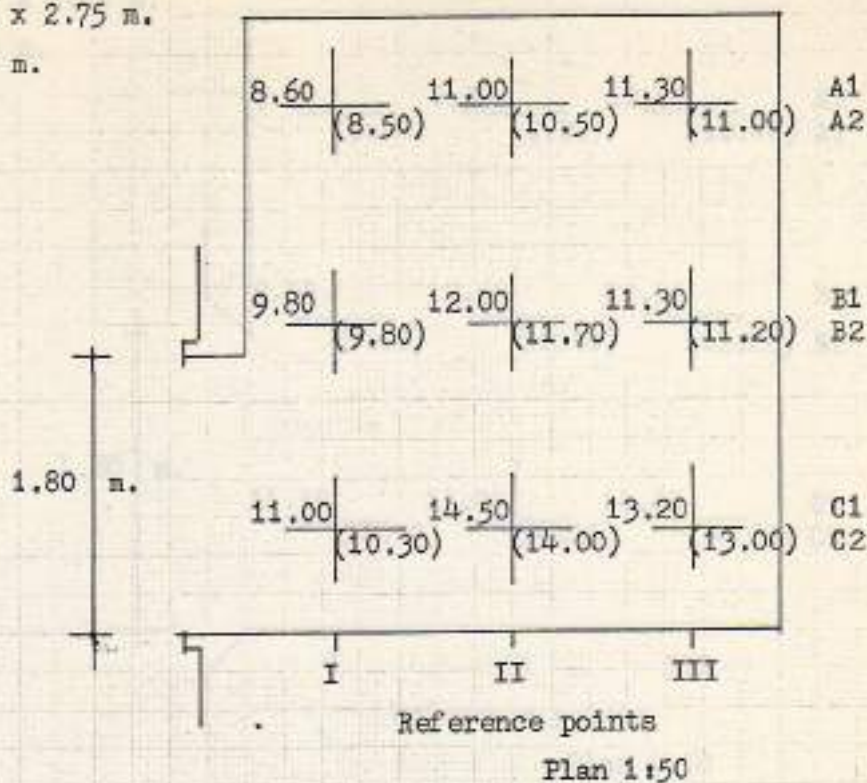

Fig. 165 Performance of window 1.80 x 1.30 Meters with square reveals

Room = 4.00 x 3.50 x 2.75 m.

Window = 1.80 x 1.30 m.

Sill = 0.90 m.

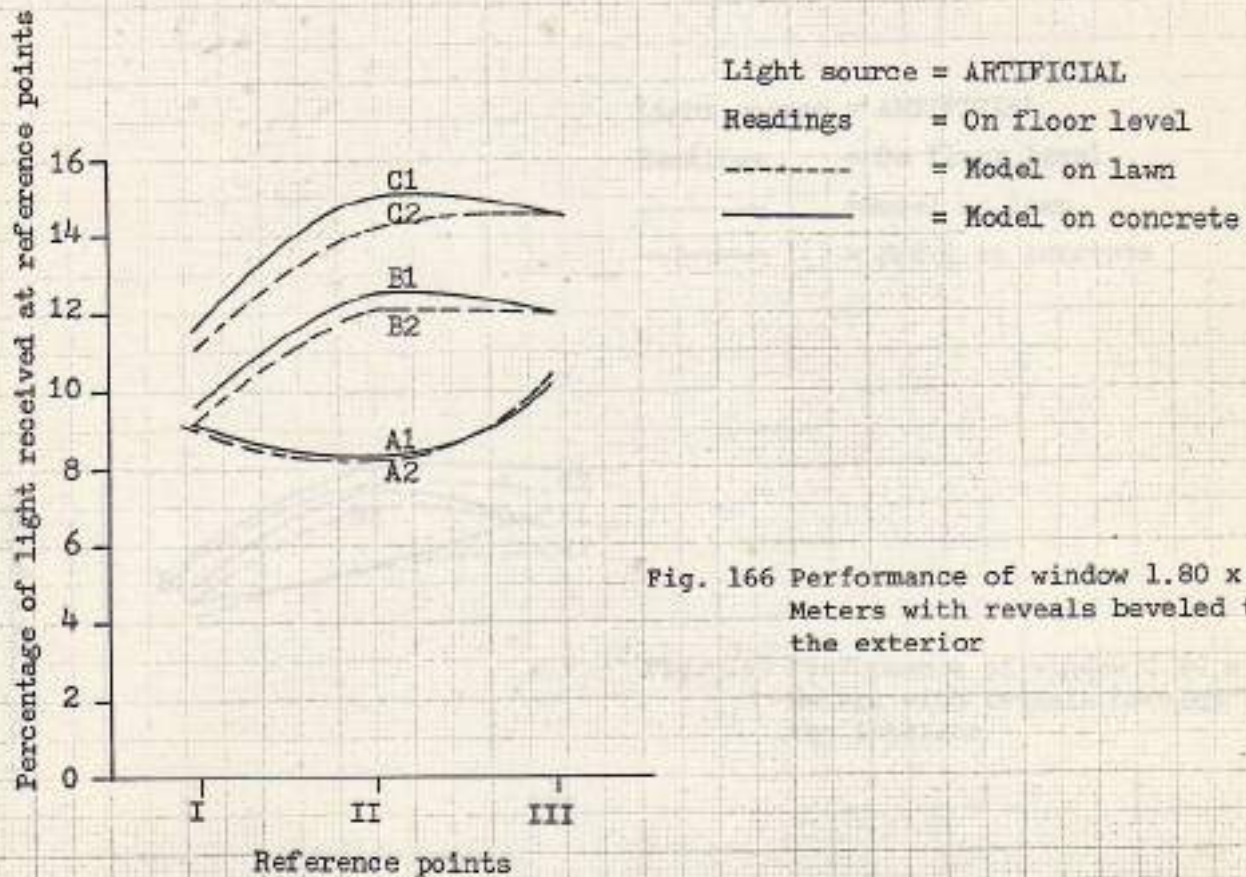
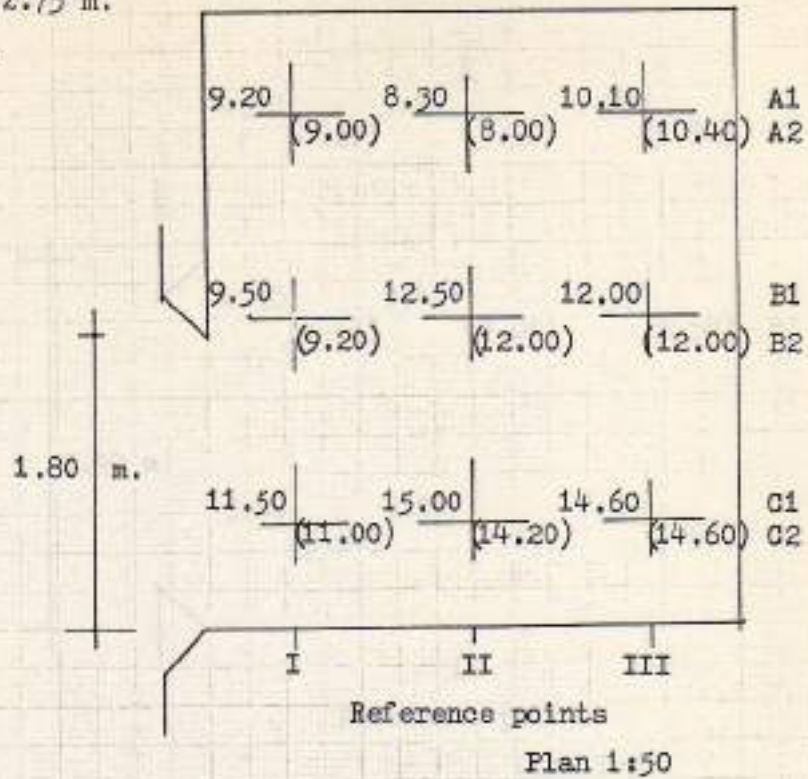
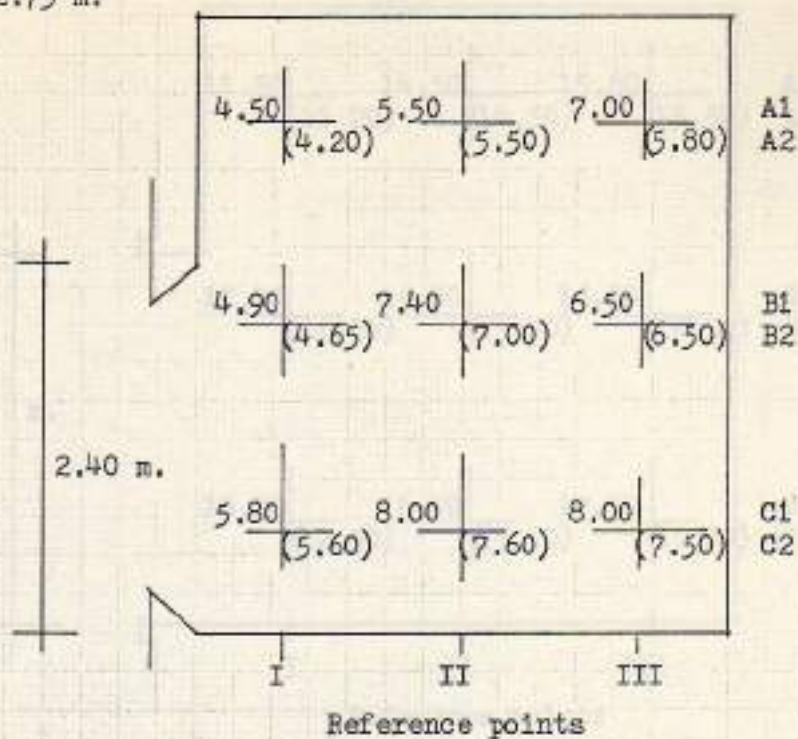

Fig. 166 Performance of window 1.80 x 1.30 Meters with reveals beveled to the exterior

Room = 4.00 x 3.50 x 2.75 m.

Window = 2.40 x 1.30 m.

Sill = 0.90 m.



Plan 1:50

Light source = ARTIFICIAL

Readings = On floor level

----- = Model on lawn

————— = Model on concrete

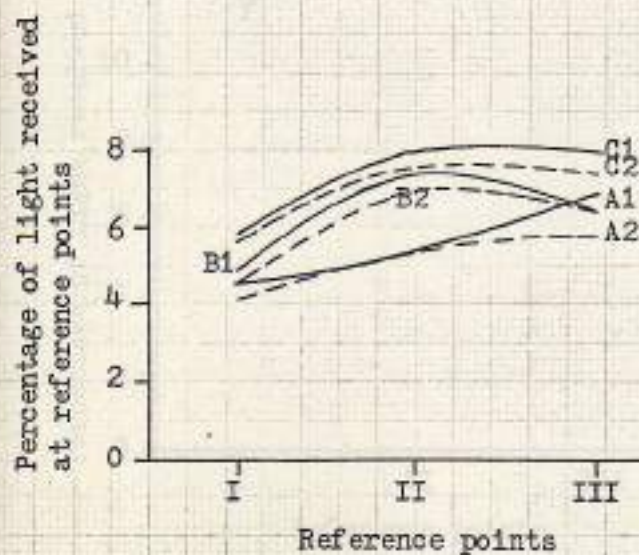
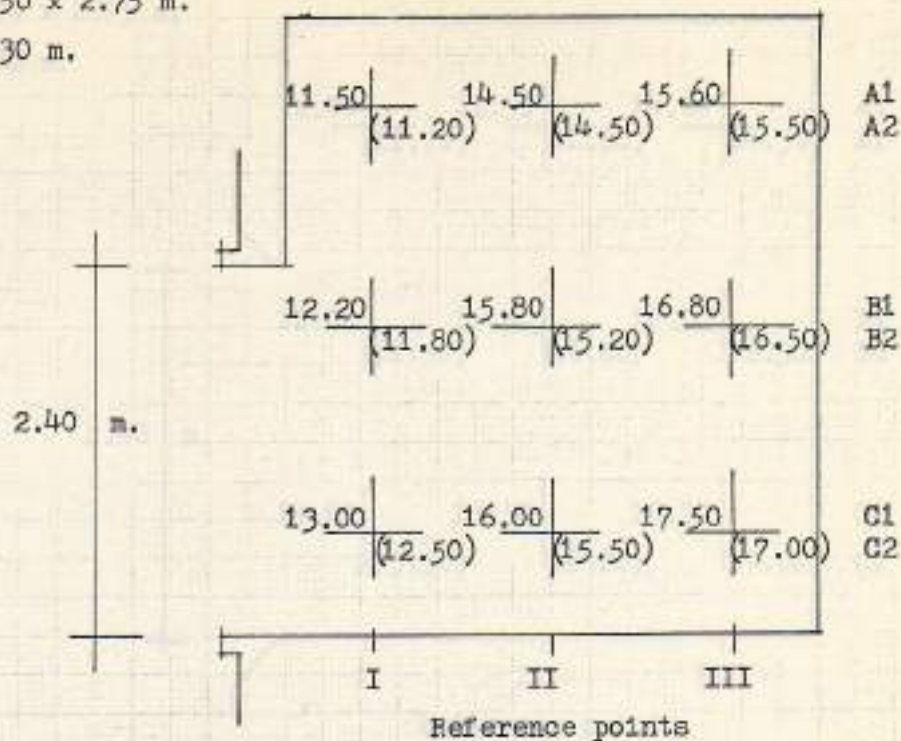

Fig. 167 Performance of window 2.40 x 1.30 Meters with reveals beveled to the interior

Room = 4.00 x 3.50 x 2.75 m.

Window = 2.40 x 1.30 m.

Sill = 0.90 m.



Plan 1:50

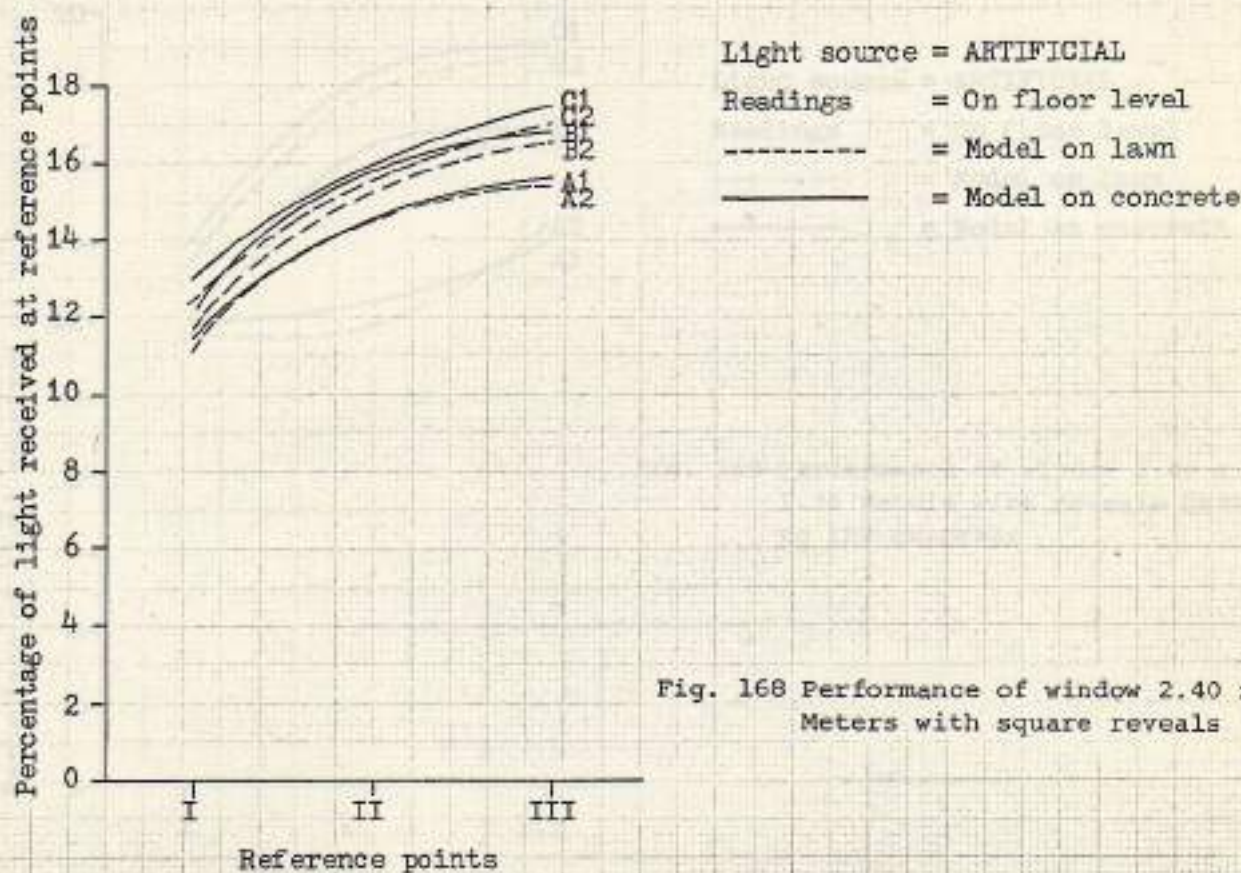
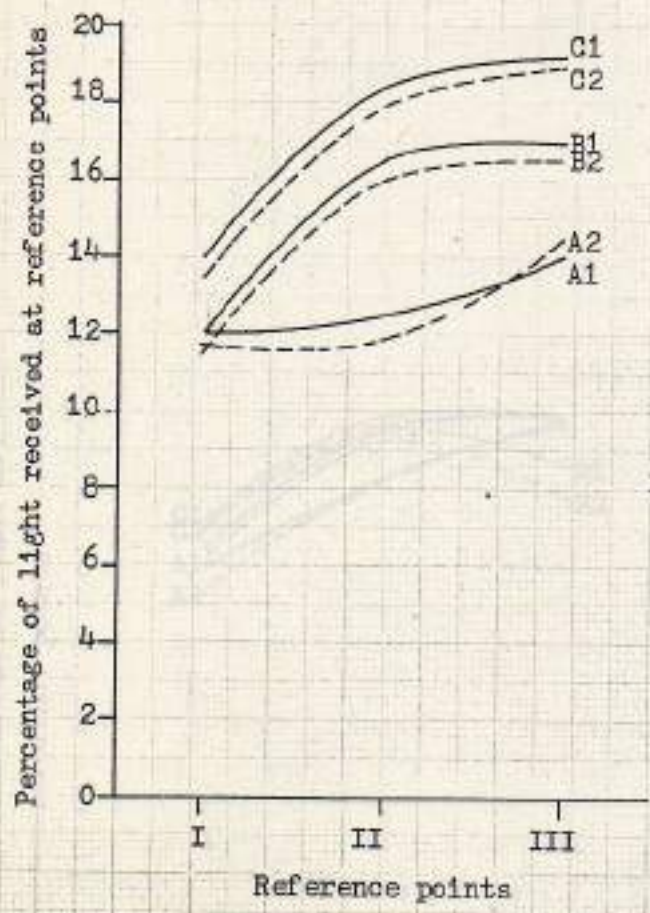
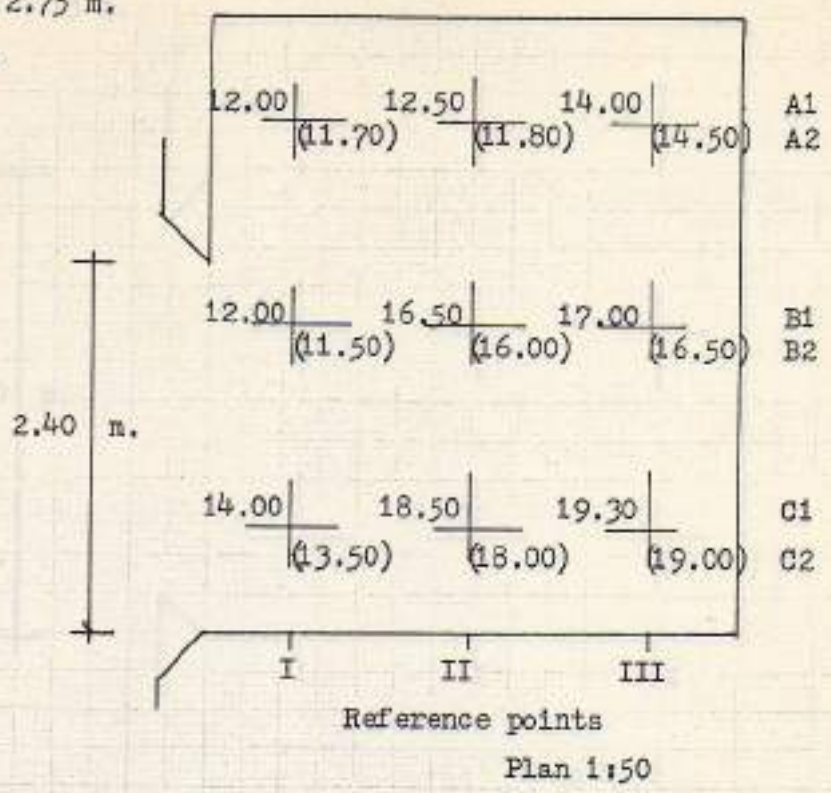

Fig. 168 Performance of window 2.40 x 1.30 Meters with square reveals

Room = 4.00 x 3.50 x 2.75 m.
 Window = 2.40 x 1.30 m.
 Sill = 0.90 m.



Light source = ARTIFICIAL
 Readings = On floor level
 ----- = Model on lawn
 _____ = Model on concrete

Fig. 169 Performance of window 2.40 x 1.30 Meters with reveals beveled to the exterior

Room = 4.00 x 3.50 x 2.75 m.

Window = 3.00 x 1.30 m.

Sill = 0.90 m.

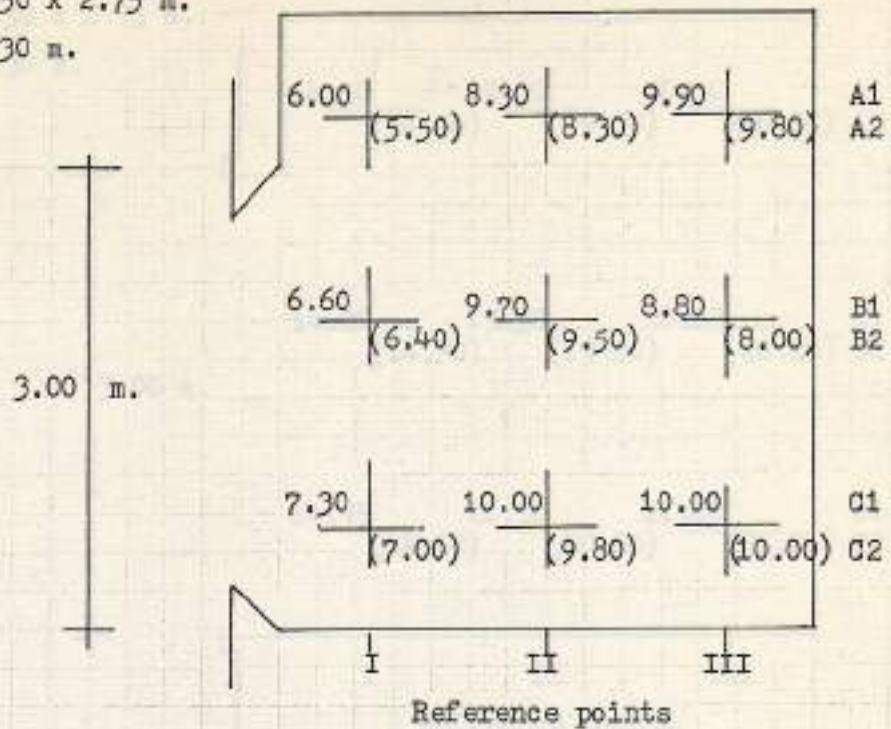

Light source = ARTIFICIAL

Readings = On floor level

----- = Model on lawn

———— = Model on concrete

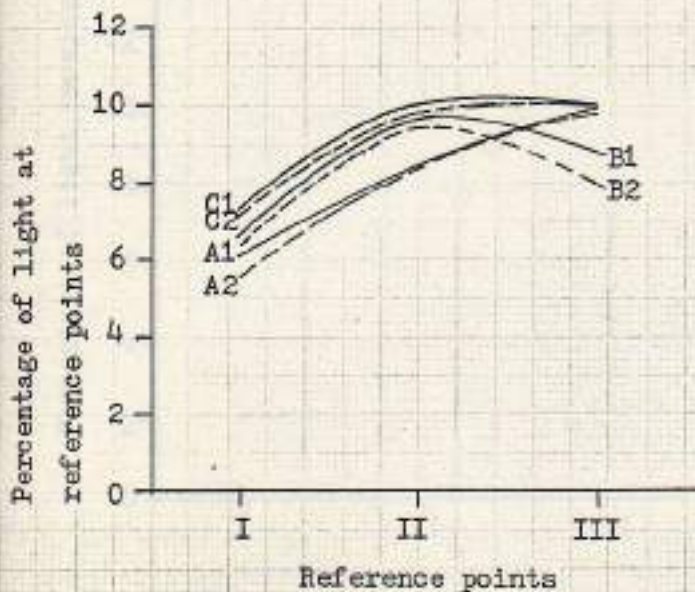

Fig. 170 Performance of window 3.00 x 1.30 Meters with reveals beveled to the interior

Room = 4.00 x 3.50 x 2.75 m.

Window = 3.00 x 1.30 m.

Sill = 0.90 m.

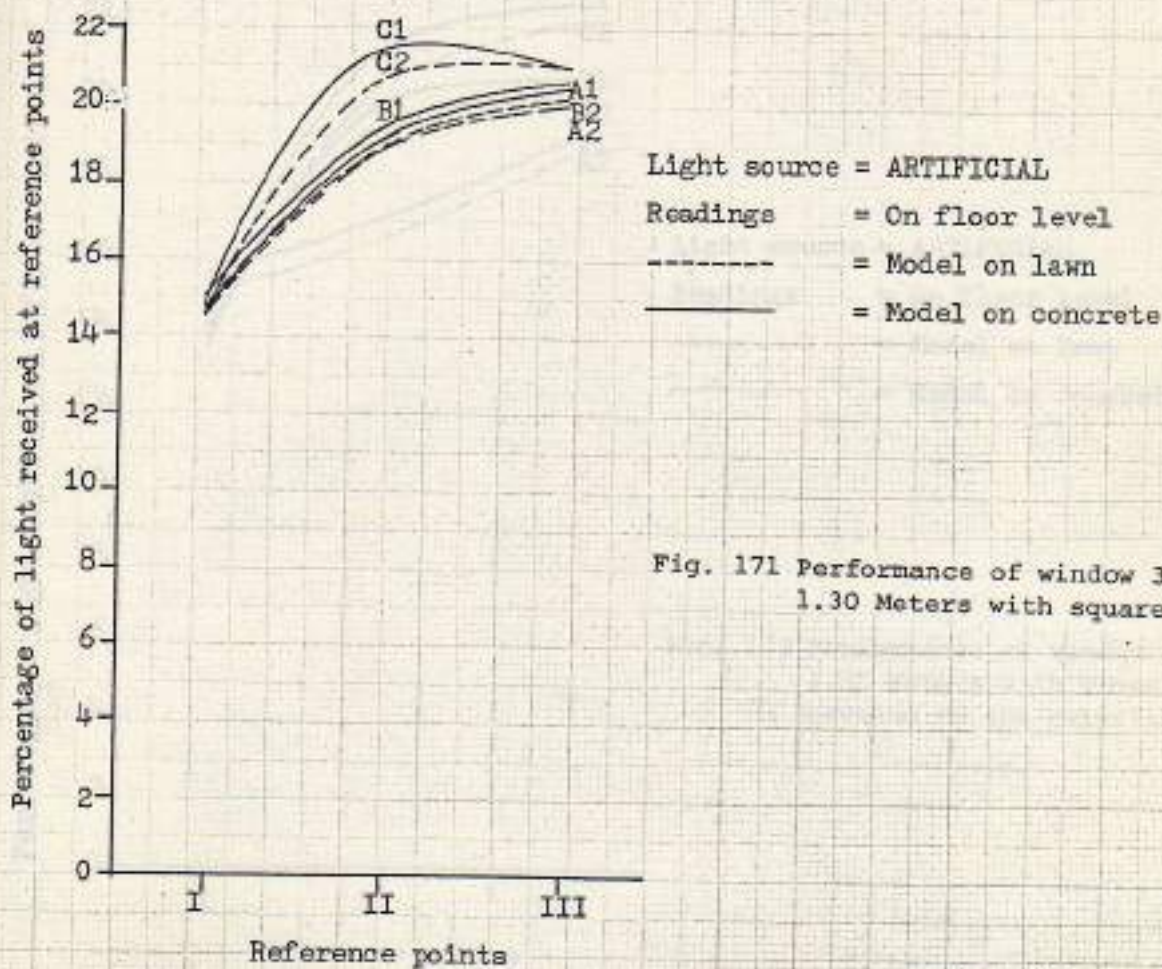
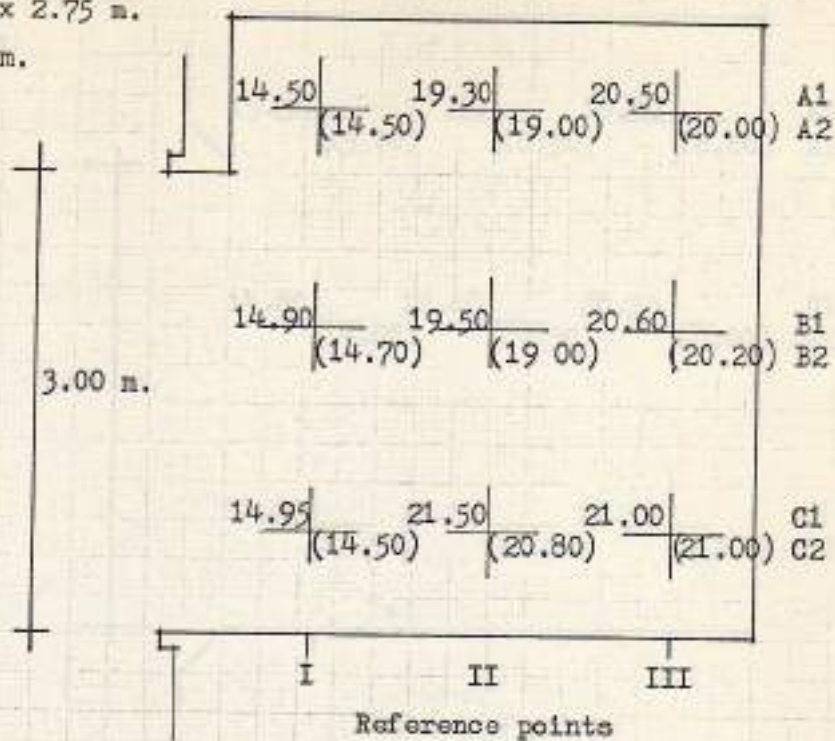

Fig. 171 Performance of window 3.00 x 1.30 Meters with square reveals

Room = 4.00 x 3.50 x 2.75 m.

Window = 3.00 x 1.30 m.

Sill = 0.90 m.

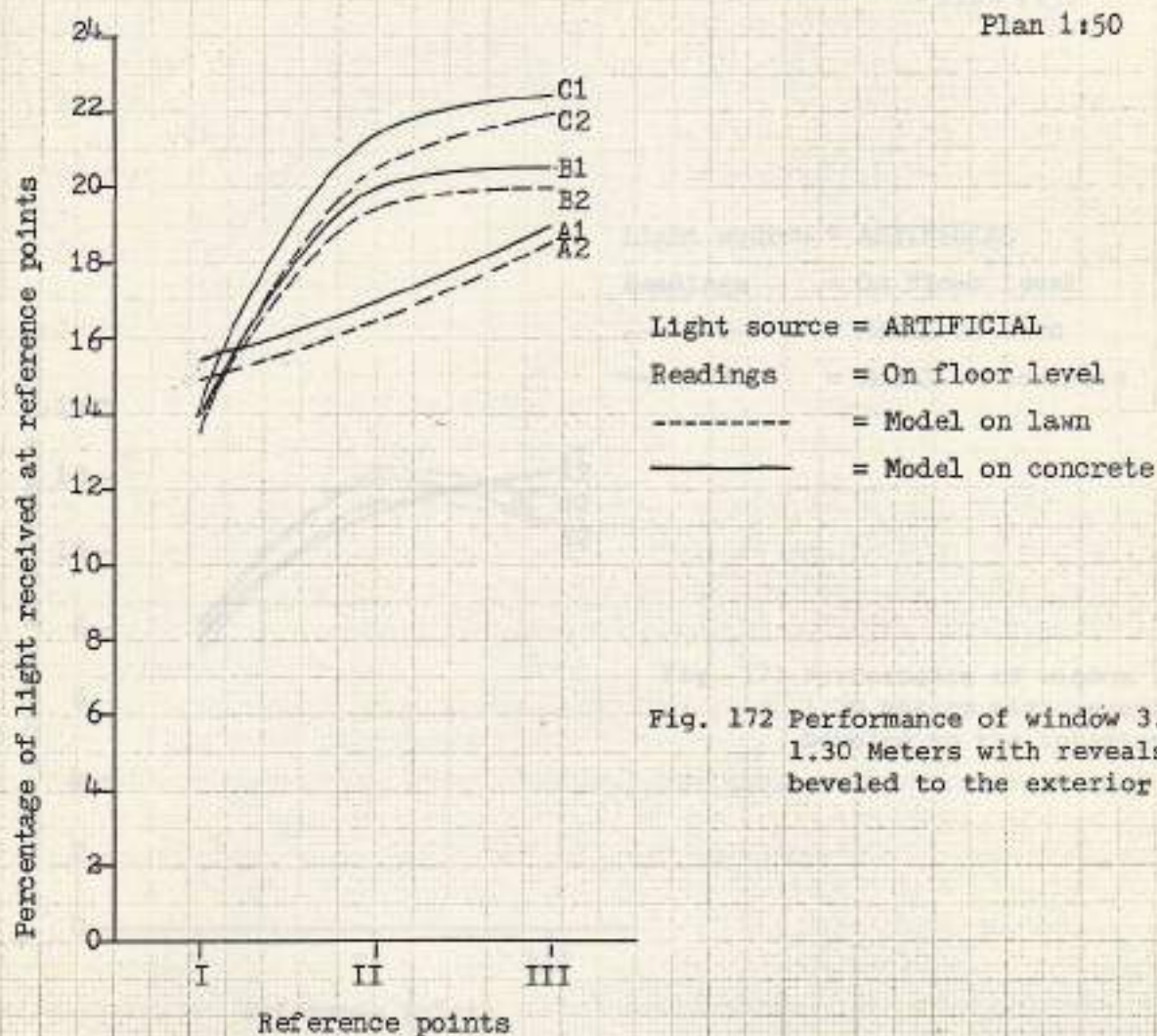
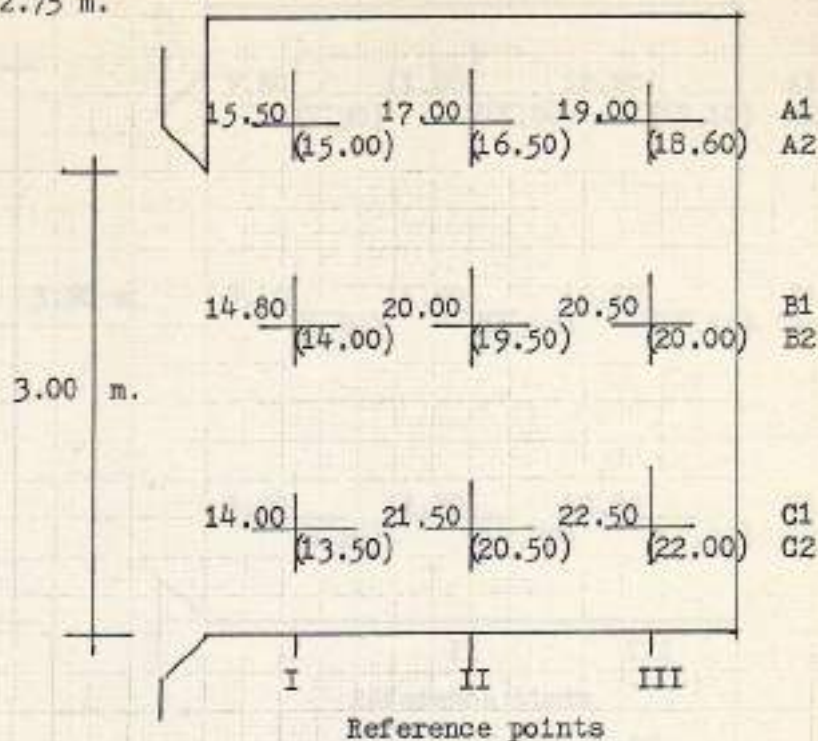
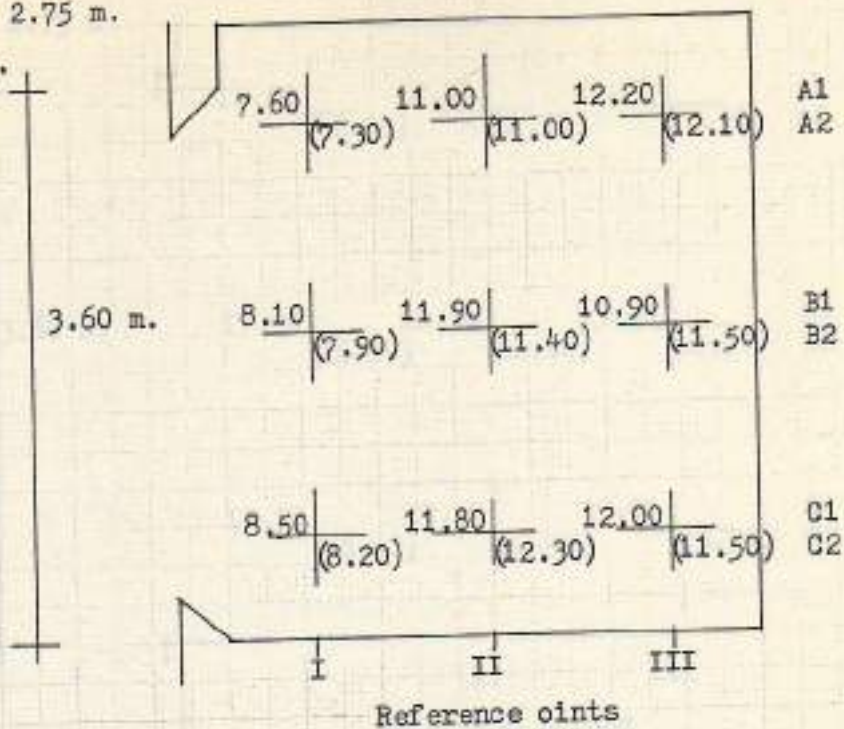

Fig. 172 Performance of window 3.00 x 1.30 Meters with reveals beveled to the exterior

Room = 4.00 x 3.50 x 2.75 m.

Window = 3.60 x 1.30 m.

Sill = 0.90 m.



Plan 1:50

Light source = ARTIFICIAL

Readings = On floor level

----- = Model on lawn

————— = Model on concrete

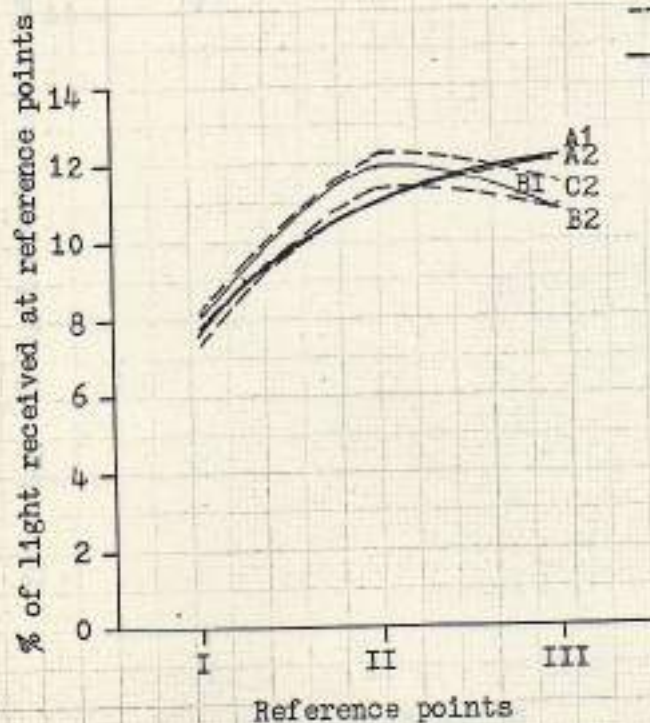
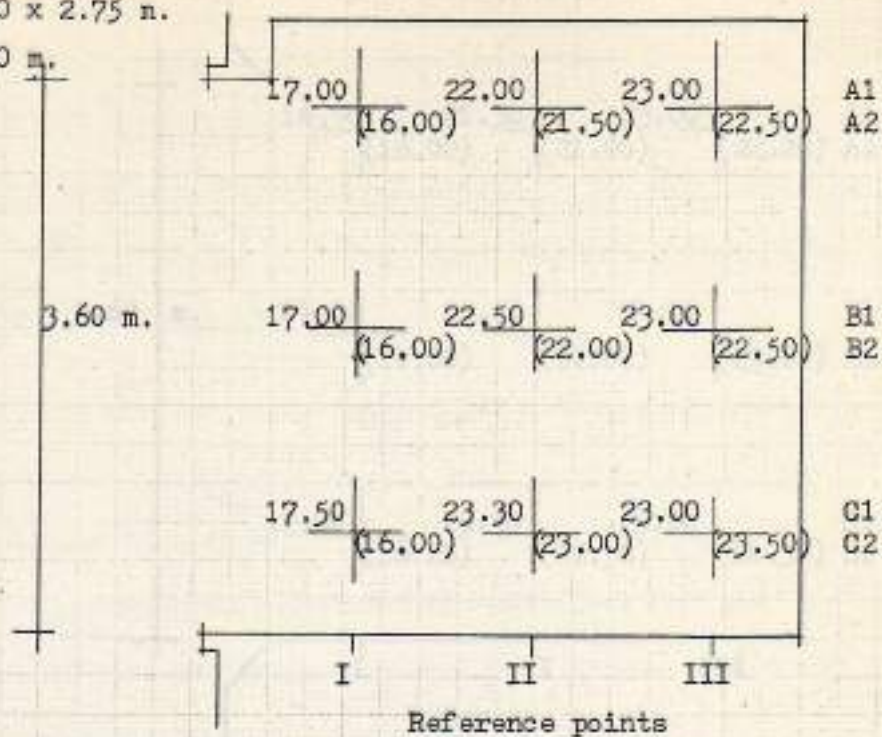

Fig. 173 Performance of window 3.60 x 1.30 Meters with reveals beveled to the interior

Room = 4.00 x 3.50 x 2.75 m.

Window = 3.60 x 1.30 m.

Sill = 0.90 m.



Plan 1:50

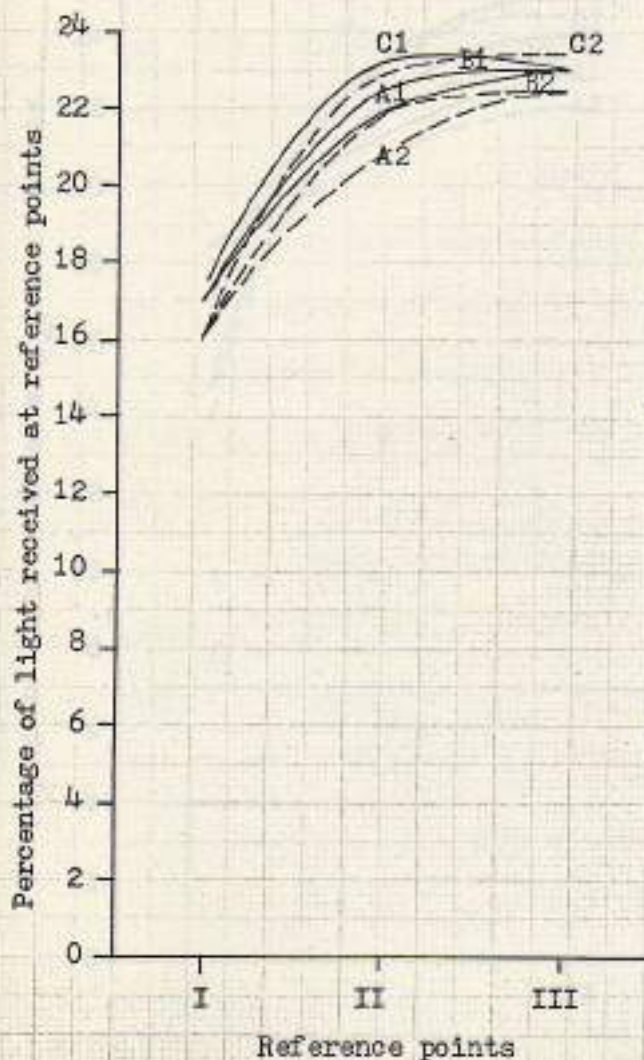

Light source = ARTIFICIAL

Readings = On floor level

----- = Model on lawn

————— = Model on concrete

Fig. 174 Performance of window 3.60 x 1.30 Meters with square reveals

Room = 4.00 x 3.50 x 2.75 m.
 Window = 3.60 x 1.30 m.
 Sill = 0.90 m.

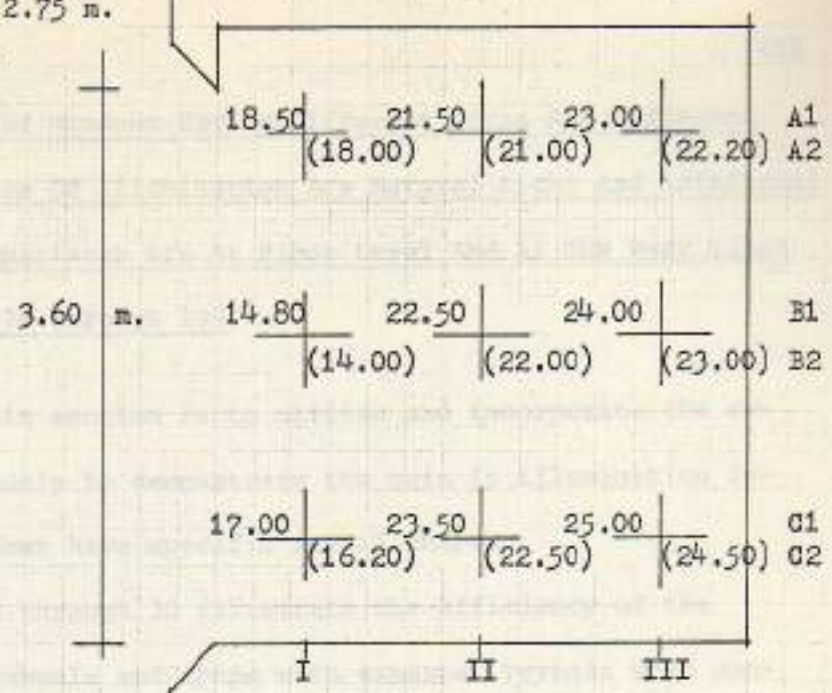

Reference points
 Plan 1:50

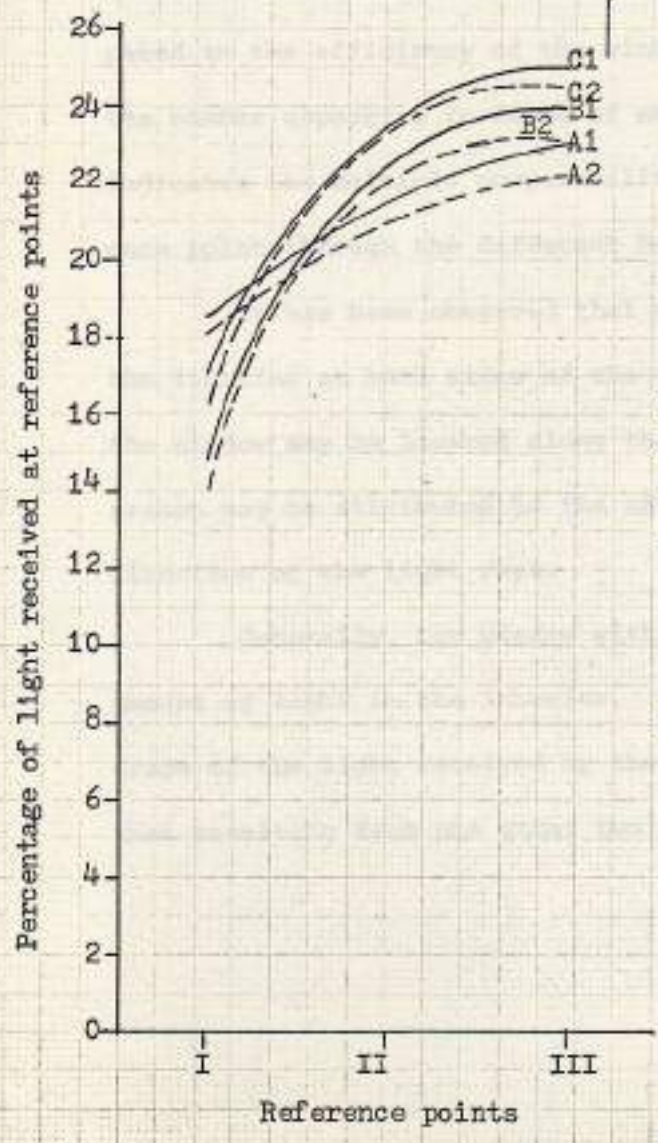

Light source = ARTIFICIAL
 Readings = On floor level
 ----- = Model on lawn
 _____ = Model on concrete

Fig. 175 Performance of window 3.60 x 1.30 Meters with reveals beveled to the exterior

Comparative Analysis Of Windows Having Different Sizes And Different Reveal Shapes. Sources Of Illumination Are Natural Light And Artificial Light. Levels Of Comparisons Are At Floor Level And At The Work Plane Level. See Figures 176 through 199.

The aim of this section is to utilize and incorporate the results obtained previously to demonstrate the gain in illumination inside rooms whose windows have specific reveal shapes.

The Tables 23 through 30 illustrate the efficiency of the windows with square reveals and those with external reveals when compared to the efficiency of the window with internal reveals. Thus, the number appearing in front of each reference point in the table indicates the multiple comparability for the light reaching the reference point through the different beveled windows.

It has been observed that no matter what kind of light is used, the lighting at both sides of the window is not symmetrical even though the window may be located along the center line of the room. The reason may be attributed to the structure of the surroundings and the direction of the light rays.

Generally, the window with external reveals admits the greatest amount of light in the interior. This is more pronounced when the average of the light received by the reference points is compared with that resulting from the other two types of windows in this experiment.

For Centered Windows (Natural Light/Work Plane)

Window Width Meters	Performances Of Windows With External Reveals As A Function Of Times Those With Internal Reveals.						Performances Of Windows With Square Reveals As A Function Of Times Those With Internal Reveals.						
	AI	BI	CI	DI	EI	FI	AI	BI	CI	DI	EI	FI	
1.20	5.37 3.00 4.00	5.51 4.29 3.71	7.97 4.94 5.99	BI BII BIII	CI CII CIII	5.77 3.00 3.00	6.13 3.46 2.96	CI CII CIII	7.36 2.85 3.11	AI AII AIII	5.20 3.90 2.72	BI BII BIII	3.83 2.36 2.12
1.80	6.59 4.63 3.75	3.86 5.55 4.54	5.20 3.90 2.72	BI BII BIII	CI CII CIII	3.57 2.60 2.23	3.95 2.82 2.33	CI CII CIII	3.83 2.36 2.12	AI AII AIII	4.35 3.85 2.38	BI BII BIII	3.21 2.55 3.60
2.40	2.65 3.44 3.52	2.20 3.34 3.08	4.35 3.85 2.38	BI BII BIII	CI CII CIII	3.01 2.69 2.65	2.55 3.07 2.40	CI CII CIII	3.21 2.55 3.60	AI AII AIII	2.95 3.19 3.48	BI BII BIII	3.55 2.45 2.44
3.00	2.19 2.55 2.99	2.09 2.24 2.73	2.95 3.19 3.48	BI BII BIII	CI CII CIII	3.04 2.52 2.17	2.21 2.12 1.91	CI CII CIII	3.55 2.45 2.44	AI AII AIII	2.19 2.75 2.63	BI BII BIII	2.58 2.49 2.27
3.60	2.67 2.50 2.62	2.00 2.15 2.43	2.19 2.75 2.63	BI BII BIII	CI CII CIII	3.27 2.65 2.13	2.08 2.04 1.96	CI CII CIII	2.58 2.49 2.27	AI AII AIII	2.55 3.34 3.72	BI BII BIII	2.75 2.14 2.03
4.00	2.06 2.70 3.00	1.99 2.32 2.70	2.55 3.34 3.72	BI BII BIII	CI CII CIII	2.18 1.85 1.82	2.15 1.93 1.95	CI CII CIII	2.75 2.14 2.03	AI AII AIII			

TABLE 23 Comparison between different windows' performances (Exterior ground cover is concrete).

FOR WINDOWS LOCATED IN THE MIDDLE OF THE FACADE (ARTIFICIAL LIGHT/WORK PLANE)

Window Width Meters	Performances Of Windows With External Reveals As A Function Of Times Those With Internal Reveals.						Performances Of Windows With Square Reveals As A Function Of Times Those With Internal Reveals.							
	AI	BI	CI	BI	CI	AI	AI	BI	CI	BI	CI	AI	BI	CI
1.20	4.83	4.83	5.35	4.83	4.25	5.11	4.38	4.19	4.38	4.19	4.38	4.38	4.38	4.19
	4.59	BII	4.62	BII	4.39	3.72	3.85	3.80	BII	3.80	BII	3.72	BII	3.80
	4.43	BIII	4.34	BIII	4.90	4.00	3.86	4.00	BIII	4.00	BIII	4.00	BIII	4.00
1.80	4.00	BI	3.84	BI	3.00	3.78	2.99	2.86	BI	2.86	BI	3.78	BI	2.86
	2.79	BII	2.83	BII	2.75	2.56	2.37	2.53	BII	2.53	BII	2.56	BII	2.53
	3.14	BIII	2.85	BIII	3.24	2.74	2.37	2.62	BIII	2.62	BIII	2.74	BIII	2.62
2.40	3.45	BI	3.12	BI	2.72	2.92	2.50	2.53	BI	2.53	BI	2.92	BI	2.53
	2.38	BII	2.41	BII	2.20	2.19	2.07	2.07	BII	2.07	BII	2.19	BII	2.07
	2.31	BIII	2.49	BIII	2.50	2.05	2.22	2.14	BIII	2.14	BIII	2.05	BIII	2.14
3.00	2.65	BI	2.77	BI	2.22	2.10	2.38	2.09	BI	2.09	BI	2.10	BI	2.09
	2.19	BII	2.17	BII	2.05	2.00	1.91	1.98	BII	1.98	BII	2.00	BII	1.98
	2.22	BIII	2.20	BIII	2.43	1.99	1.97	2.04	BIII	2.04	BIII	1.99	BIII	2.04
3.60	3.04	BI	2.48	BI	2.75	2.63	2.22	2.48	BI	2.48	BI	2.63	BI	2.48
	2.17	BII	2.07	BII	1.91	1.89	1.82	1.85	BII	1.85	BII	1.89	BII	1.85
	2.13	BIII	2.03	BIII	2.15	1.91	1.88	1.91	BIII	1.91	BIII	1.91	BIII	1.91
4.00	2.64	BI	2.30	BI	2.59	2.22	2.07	2.37	BI	2.37	BI	2.22	BI	2.37
	1.90	BII	1.90	BII	1.86	1.83	1.78	1.79	BII	1.79	BII	1.83	BII	1.79
	2.00	BIII	1.95	BIII	1.92	1.81	1.71	1.73	BIII	1.73	BIII	1.81	BIII	1.73

TABLE 24 Comparison between different windows' performances (Exterior ground cover is concrete).

For Centered Windows (Natural Light/Floor Level)

Window Width Meters	Performances Of Windows With External Reveals As A Function Of Times Those With Internal Reveals.						Performances Of Windows With Square Reveals As A Function Of Times Those With Internal Reveals.					
	AI	BII	BIII	CI	CII	CIII	AI	BII	BIII	CI	CII	CIII
1.20	5.58	3.18	3.18	3.18	2.76	2.75	3.83	2.64	2.48	2.58	2.30	2.63
1.80	2.51	3.51	3.51	2.62	2.86	2.71	2.03	2.00	2.17	2.02	2.30	2.36
2.40	2.31	2.26	2.26	2.16	2.20	3.27	1.88	1.85	1.81	2.21	2.06	2.36
3.00	1.85	2.02	2.02	2.20	2.29	2.26	1.44	1.71	1.83	2.53	3.20	2.12
3.60	2.09	2.08	2.08	1.86	1.85	2.05	1.75	1.70	1.56	2.55	2.20	1.91
4.00	1.84	1.64	1.64	1.62	1.66	2.14	1.59	1.63	1.61	2.45	2.03	2.20

TABLE 25 Comparison between different windows' performances (Exterior ground cover is concrete).

For Centered Windows (Artificial Light/Floor Level)

Window Width Meters	Performances Of Windows With External Reveals As A Function Of Times Those With Internal Reveals.						Performances Of Windows With Square Reveals As A Function Of Times Those With Internal Reveals.						
	AI	BI	CI	BI	CI	AI	BI	CI	BI	CI	AI	BI	CI
1.20	4.70	4.55	4.45	4.70	4.55	4.45	3.82	3.91	4.26	3.82	3.91	4.26	3.87
	5.00	4.13	3.63	5.00	4.13	3.63	4.25	3.91	3.91	4.25	3.91	3.91	3.75
	5.51	4.90	3.57	5.51	4.90	3.57	4.76	4.05	4.05	4.76	4.05	4.05	2.51
1.80	3.09	2.99	3.19	3.09	2.99	3.19	2.46	2.84	2.84	2.46	2.84	2.84	2.74
	2.88	2.35	2.19	2.88	2.35	2.19	2.60	2.35	2.35	2.60	2.35	2.35	2.95
	2.96	3.62	3.27	2.96	3.62	3.27	2.60	2.85	2.85	2.60	2.85	2.85	2.36
2.40	2.55	2.82	2.64	2.55	2.82	2.64	1.87	2.67	2.67	1.87	2.67	2.67	2.32
	2.33	2.05	2.01	2.33	2.05	2.01	2.20	2.15	2.15	2.20	2.15	2.15	2.13
	2.38	2.67	2.88	2.38	2.67	2.88	2.18	2.29	2.29	2.18	2.29	2.29	2.12
3.00	2.20	2.17	2.36	2.20	2.17	2.36	1.87	2.10	2.10	1.87	2.10	2.10	2.05
	2.10	1.91	1.90	2.10	1.91	1.90	2.05	1.95	1.95	2.05	1.95	1.95	2.00
	1.81	2.47	2.72	1.81	2.47	2.72	2.00	2.05	2.05	2.00	2.05	2.05	1.99
3.60	2.12	2.10	2.13	2.12	2.10	2.13	1.90	2.07	2.07	1.90	2.07	2.07	1.98
	1.96	1.75	1.75	1.96	1.75	1.75	1.96	1.84	1.84	1.96	1.84	1.84	1.93
	1.93	2.25	2.60	1.93	2.25	2.60	1.85	1.85	1.85	1.85	1.85	1.85	1.88
4.00	2.10	1.92	2.00	2.10	1.92	2.00	1.85	1.83	1.83	1.85	1.83	1.83	1.82
	1.85	1.64	1.81	1.85	1.64	1.81	1.76	1.71	1.71	1.76	1.71	1.71	1.86
	1.76	2.25	1.93	1.76	2.25	1.93	1.76	1.94	1.94	1.76	1.94	1.94	1.85

TABLE 26 Comparison between different windows' performances (Exterior ground cover is concrete).

For Windows At One Side Of The Wall (Artificial Light/Work Plane)

Window Width Meters	Performances Of Windows With External Reveals As A Function Of Times Those With Internal Reveals.						Performances Of Windows With Square Reveals As A Function Of Times Those With Internal Reveals.						
	AI	BI	CI	BI	CI	AI	BI	CI	BI	CI	AI	BI	CI
1.20	4.15	4.19	4.58	4.56	4.56	5.19	4.53	4.56	4.56	4.56	5.19	4.53	4.53
	3.79	4.05	3.64	3.86	3.64	4.15	3.45	3.86	3.64	3.86	4.15	3.45	3.45
	4.07	4.46	4.18	4.13	4.18	3.64	3.86	4.13	4.13	3.86	3.64	3.86	3.86
1.80	3.14	3.51	3.31	3.22	3.31	3.95	2.99	3.22	3.22	3.22	3.95	2.99	2.99
	2.81	2.69	2.58	2.50	2.58	2.65	2.92	2.50	2.50	2.50	2.65	2.92	2.92
	4.15	2.98	2.87	2.94	2.87	2.61	2.55	2.94	2.94	2.61	2.61	2.55	2.55
2.40	2.78	2.88	2.94	2.84	2.94	2.92	2.89	2.84	2.84	2.84	2.92	2.89	2.89
	2.10	2.27	2.21	2.13	2.21	2.16	2.08	2.13	2.13	2.13	2.16	2.08	2.08
	2.35	2.56	2.33	2.33	2.33	2.16	2.12	2.33	2.33	2.16	2.16	2.12	2.12
3.00	2.63	2.73	2.67	2.68	2.67	2.78	2.52	2.68	2.68	2.68	2.78	2.52	2.52
	2.02	2.14	2.10	1.98	2.10	1.88	1.96	1.98	1.98	1.88	1.88	1.96	1.96
	2.12	2.18	2.09	2.09	2.09	1.95	1.92	2.09	2.09	1.95	1.95	1.92	1.92
3.60	2.82	2.40	2.55	2.71	2.55	2.35	2.39	2.71	2.71	2.71	2.35	2.39	2.39
	1.93	1.96	1.95	1.87	1.95	1.76	1.85	1.87	1.87	1.76	1.76	1.85	1.85
	2.05	2.07	1.97	1.99	1.97	1.87	1.86	1.99	1.99	1.87	1.87	1.86	1.86

TABLE 27 Comparison between different windows' performances (Exterior ground cover is concrete).

For Windows At One Side Of The Wall (Natural Light/Work Plane)

Window Width Meters	Performances Of Windows With External Reveals As A Function Of Times Those With Internal Reveals.						Performances Of Windows With Square Reveals As A Function Of Times Those With Internal Reveals.						
	AI	BI	CI	BI	CI	AI	BI	CI	BI	CI	AI	BI	CI
1.20	2.05 2.04 1.90	3.39 3.52 3.79	3.15 5.12 4.64	2.05 2.04 1.90	3.39 3.52 3.79	3.15 5.12 4.64	2.05 2.04 1.90	3.39 3.52 3.79	2.05 2.04 1.90	3.39 3.52 3.79	3.15 5.12 4.64	2.05 2.04 1.90	3.39 3.52 3.79
1.80	2.54 2.63 2.74	5.22 3.51 3.64	3.00 4.30 3.45	2.54 2.63 2.74	5.22 3.51 3.64	3.00 4.30 3.45	2.54 2.63 2.74	5.22 3.51 3.64	2.54 2.63 2.74	5.22 3.51 3.64	3.00 4.30 3.45	2.54 2.63 2.74	5.22 3.51 3.64
2.40	2.71 2.67 2.47	3.52 2.81 2.50	3.20 3.10 2.70	2.71 2.67 2.47	3.52 2.81 2.50	3.20 3.10 2.70	2.71 2.67 2.47	3.52 2.81 2.50	2.71 2.67 2.47	3.52 2.81 2.50	3.20 3.10 2.70	2.71 2.67 2.47	3.52 2.81 2.50
3.00	3.45 2.91 2.51	2.96 3.79 3.33	3.04 2.64 2.72	3.45 2.91 2.51	2.96 3.79 3.33	3.04 2.64 2.72	3.45 2.91 2.51	2.96 3.79 3.33	3.45 2.91 2.51	2.96 3.79 3.33	3.04 2.64 2.72	3.45 2.91 2.51	2.96 3.79 3.33
3.60	3.35 2.67 2.53	2.66 3.07 2.84	2.65 2.92 2.86	3.35 2.67 2.53	2.66 3.07 2.84	2.65 2.92 2.86	3.35 2.67 2.53	2.66 3.07 2.84	3.35 2.67 2.53	2.66 3.07 2.84	2.65 2.92 2.86	3.35 2.67 2.53	2.66 3.07 2.84

TABLE 28 Comparison between different windows' performances (Exterior ground cover is concrete).

For Windows At One Side Of The Wall (Natural Light/ Floor Level)

Window Width Meters	Performances Of Windows With External Reveals As A Function Of Times Those With Internal Reveals.						Performances Of Windows With Square Reveals As A Function Of Times Those With Internal Reveals.					
	AI	BI	CI	DI	EI	FI	AI	BI	CI	DI	EI	FI
1.20	4.35	3.43	2.96	4.14	3.21	2.66	4.35	3.43	2.96	4.14	3.21	2.66
	5.95	3.67	3.80	5.92	3.43	2.78	5.95	3.67	3.80	5.92	3.43	2.78
	7.20	3.67	4.00	7.76	3.25	3.15	7.20	3.67	4.00	7.76	3.25	3.15
1.80	1.98	2.42	2.73	1.99	2.22	2.39	1.98	2.42	2.73	1.99	2.22	2.39
	2.48	2.45	2.78	2.50	2.24	2.18	2.48	2.45	2.78	2.50	2.24	2.18
	2.39	2.93	3.00	2.57	2.47	2.45	2.39	2.93	3.00	2.57	2.47	2.45
2.40	2.25	2.39	2.45	2.15	2.07	2.01	2.25	2.39	2.45	2.15	2.07	2.01
	2.43	2.75	2.99	2.32	2.06	2.03	2.43	2.75	2.99	2.32	2.06	2.03
	2.54	2.81	2.67	2.50	2.40	2.13	2.54	2.81	2.67	2.50	2.40	2.13
3.00	2.11	1.86	2.22	2.22	2.14	1.94	2.11	1.86	2.22	2.22	2.14	1.94
	3.38	2.73	3.70	2.18	2.19	2.12	3.38	2.73	3.70	2.18	2.19	2.12
	2.43	2.89	2.77	2.53	2.33	2.10	2.43	2.89	2.77	2.53	2.33	2.10
3.60	2.25	2.25	2.15	2.24	1.95	1.84	2.25	2.25	2.15	2.24	1.95	1.84
	2.99	2.69	2.68	2.21	1.90	1.90	2.99	2.69	2.68	2.21	1.90	1.90
	2.27	2.76	2.63	2.09	2.12	1.94	2.27	2.76	2.63	2.09	2.12	1.94

TABLE 29 Comparison between different windows' performances (Exterior ground cover is concrete).

For Windows At One Side Of The Wall (Artificial Light/Floor Level)

Window Width Meters	Performances Of Windows With External Reveals As A Function Of Times Those With Internal Reveals.						Performances Of Windows With Square Reveals As A Function Of Times Those With Internal Reveals.					
	AI	BI	CI	DI	EI	FI	AI	BI	CI	DI	EI	FI
1.20	4.00	3.83	4.05	4.05	4.05	4.05	3.81	3.89	3.81	3.81	3.89	3.66
	2.82	4.05	4.05	4.04	4.04	4.04	4.18	4.05	4.18	4.18	4.05	3.92
	3.81	4.44	4.44	4.55	4.55	4.55	4.11	4.83	4.11	4.11	4.83	4.32
1.80	3.02	2.98	2.98	2.95	2.95	2.95	2.82	3.07	2.82	2.82	3.07	2.82
	2.85	2.91	2.91	2.59	2.59	2.59	3.79	2.79	3.79	3.79	2.79	2.50
	2.40	3.00	3.00	3.04	3.04	3.04	2.69	2.83	2.69	2.69	2.83	2.75
2.40	2.67	2.45	2.45	2.41	2.41	2.41	2.55	2.49	2.55	2.55	2.49	2.24
	2.27	2.23	2.23	2.31	2.31	2.31	2.64	2.14	2.64	2.64	2.14	2.00
	2.00	2.62	2.62	2.41	2.41	2.41	2.23	2.58	2.23	2.23	2.58	2.19
3.00	2.58	2.24	2.24	1.92	1.92	1.92	2.43	2.25	2.43	2.43	2.25	2.05
	2.05	2.06	2.06	2.15	2.15	2.15	2.33	2.11	2.33	2.33	2.11	2.15
	1.92	2.33	2.33	2.25	2.25	2.25	2.07	2.34	2.07	2.07	2.34	2.10
3.60	2.43	1.83	1.83	2.00	2.00	2.00	2.24	2.10	2.24	2.24	2.10	2.06
	1.95	1.89	1.89	1.99	1.99	1.99	2.00	1.89	2.00	2.00	1.89	1.97
	1.84	2.20	2.20	2.08	2.08	2.08	1.89	2.11	1.89	1.89	2.11	1.92

TABLE 30 Comparison between different windows' performances (Exterior ground cover is concrete).

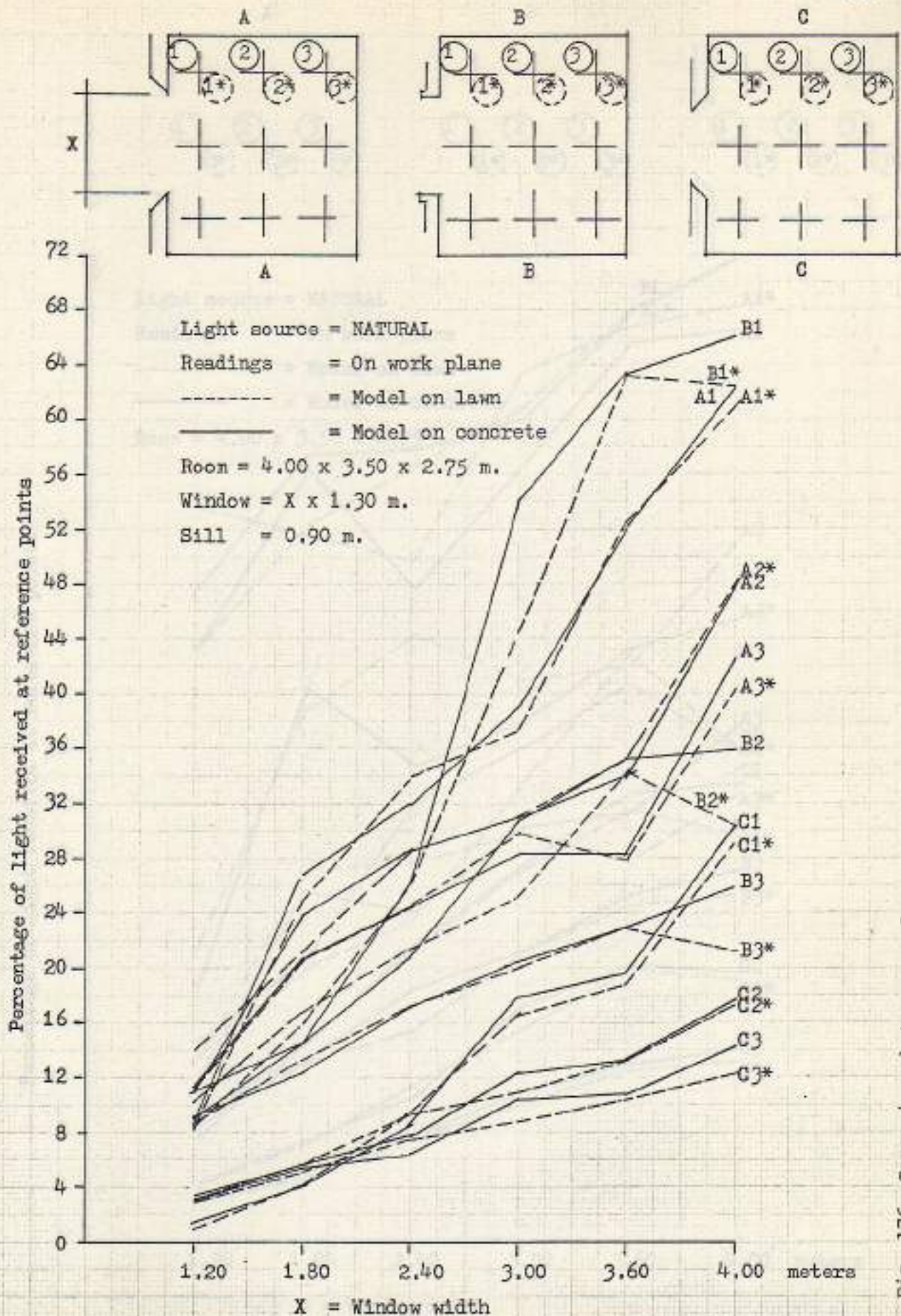

Fig. 176 Comparison between performances of windows with different reveal types for selected reference points

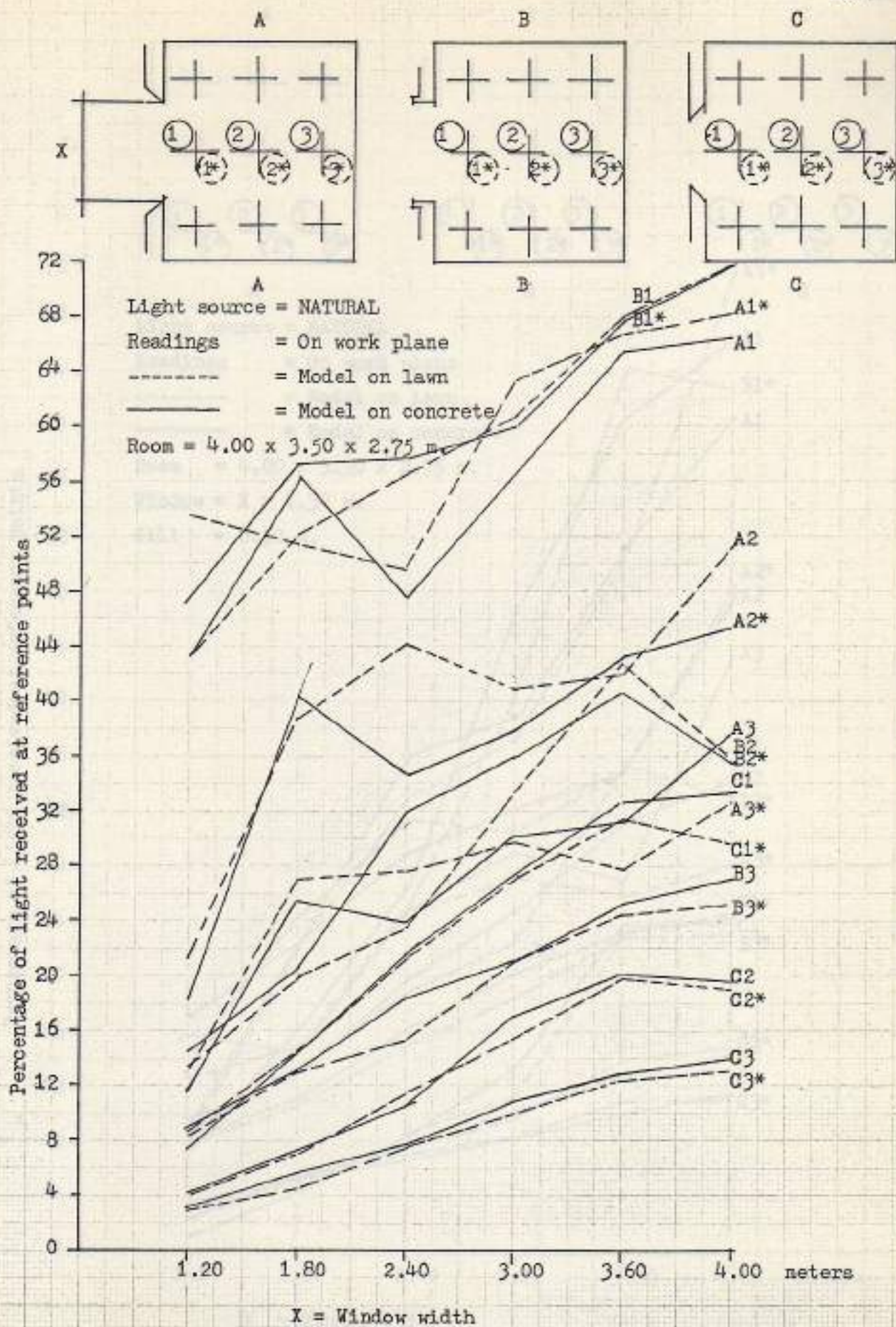

Fig. 177 Comparison between the performances of windows with different reveal shapes for reference points located axial to the windows

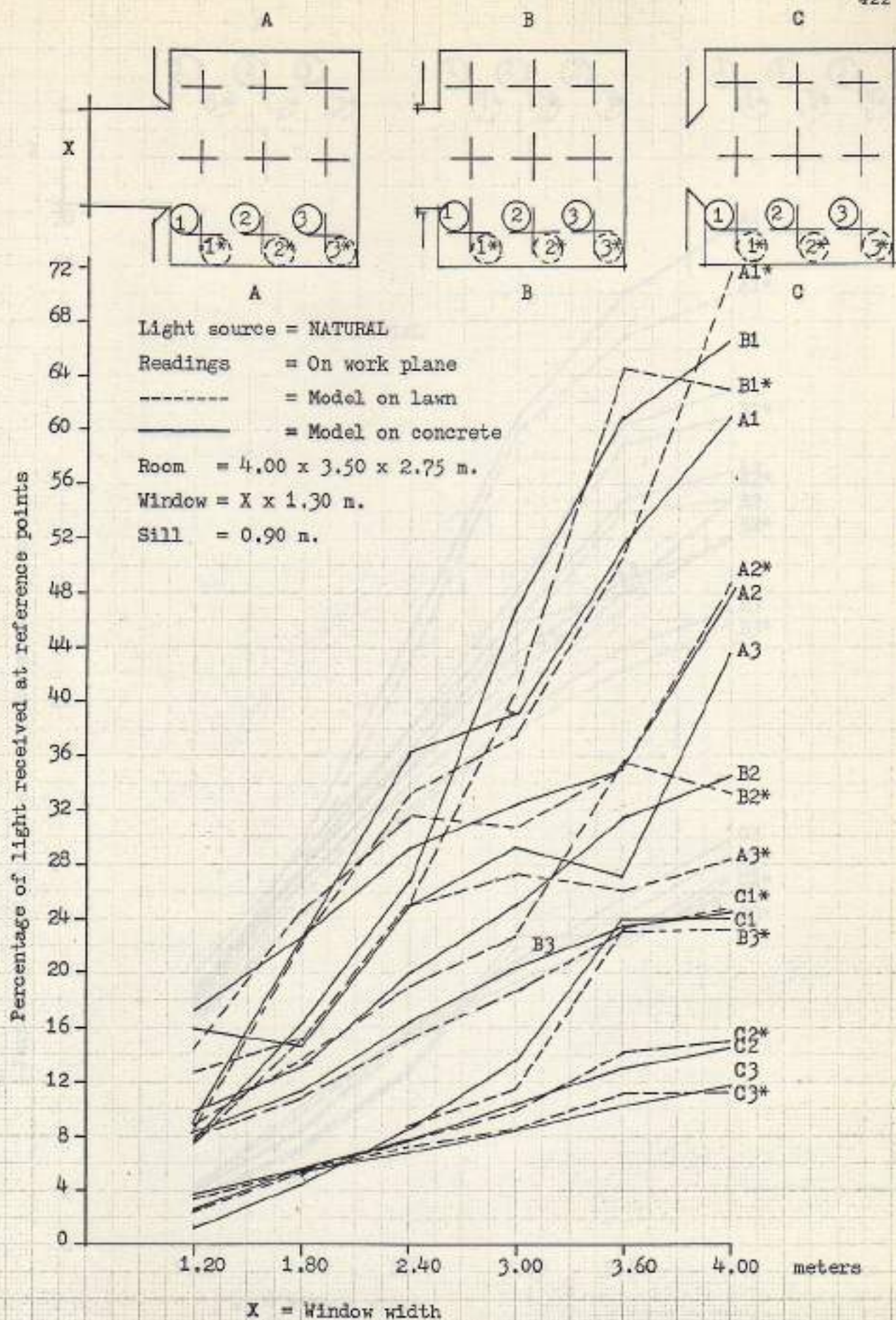

Fig. 178 Comparison between performances of windows with different reveal shapes for reference points off center of the windows

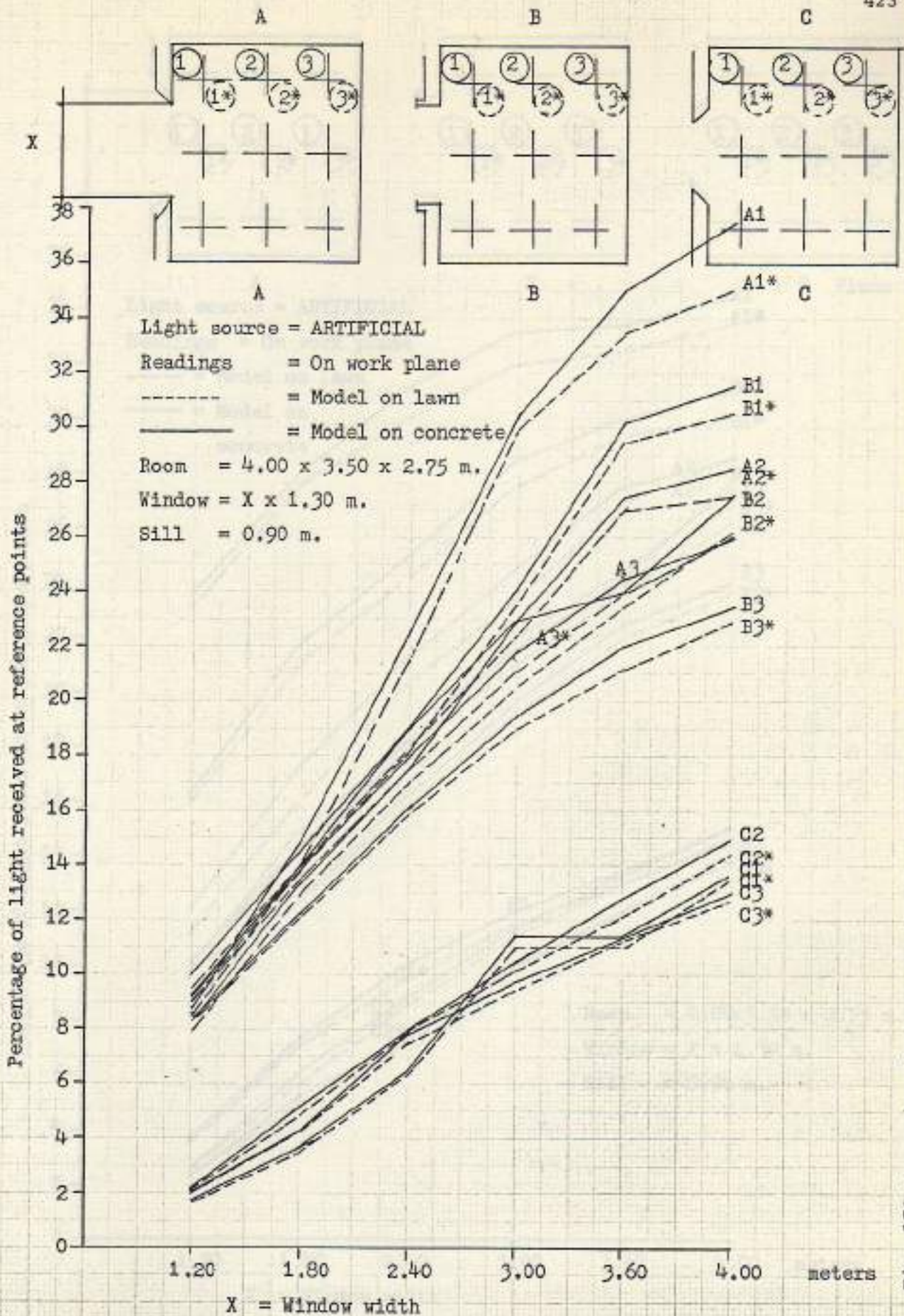

Fig. 179 Comparison between performances of windows having different reveal shapes for selected reference points

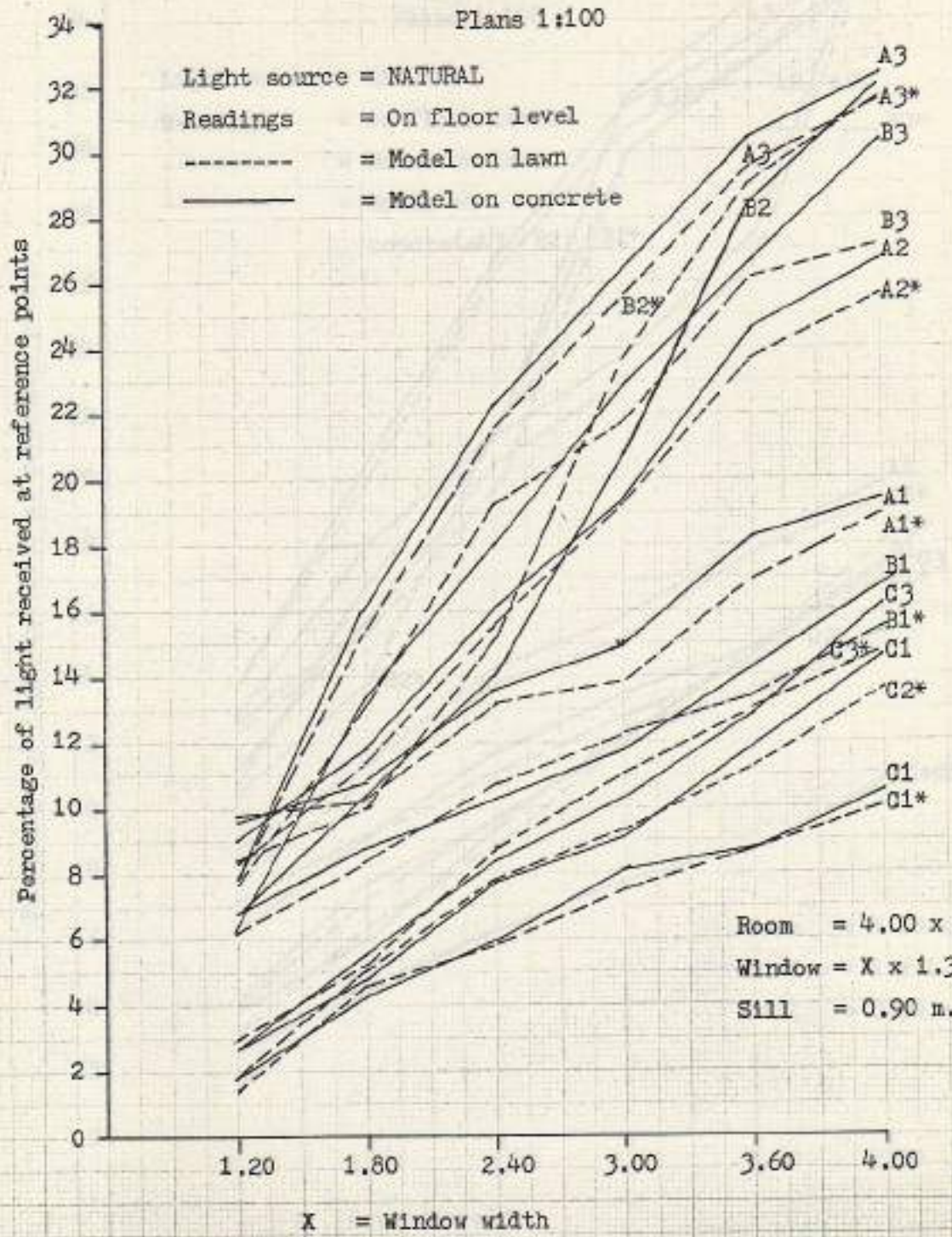
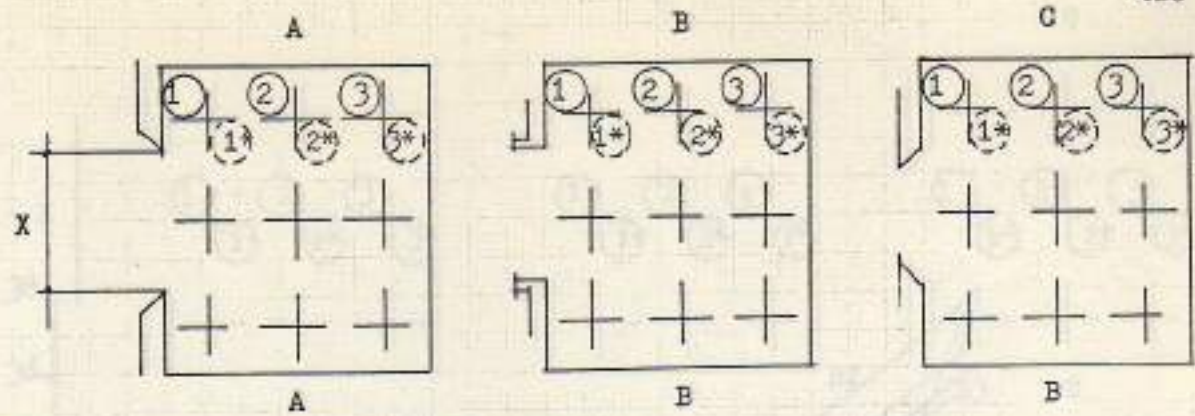
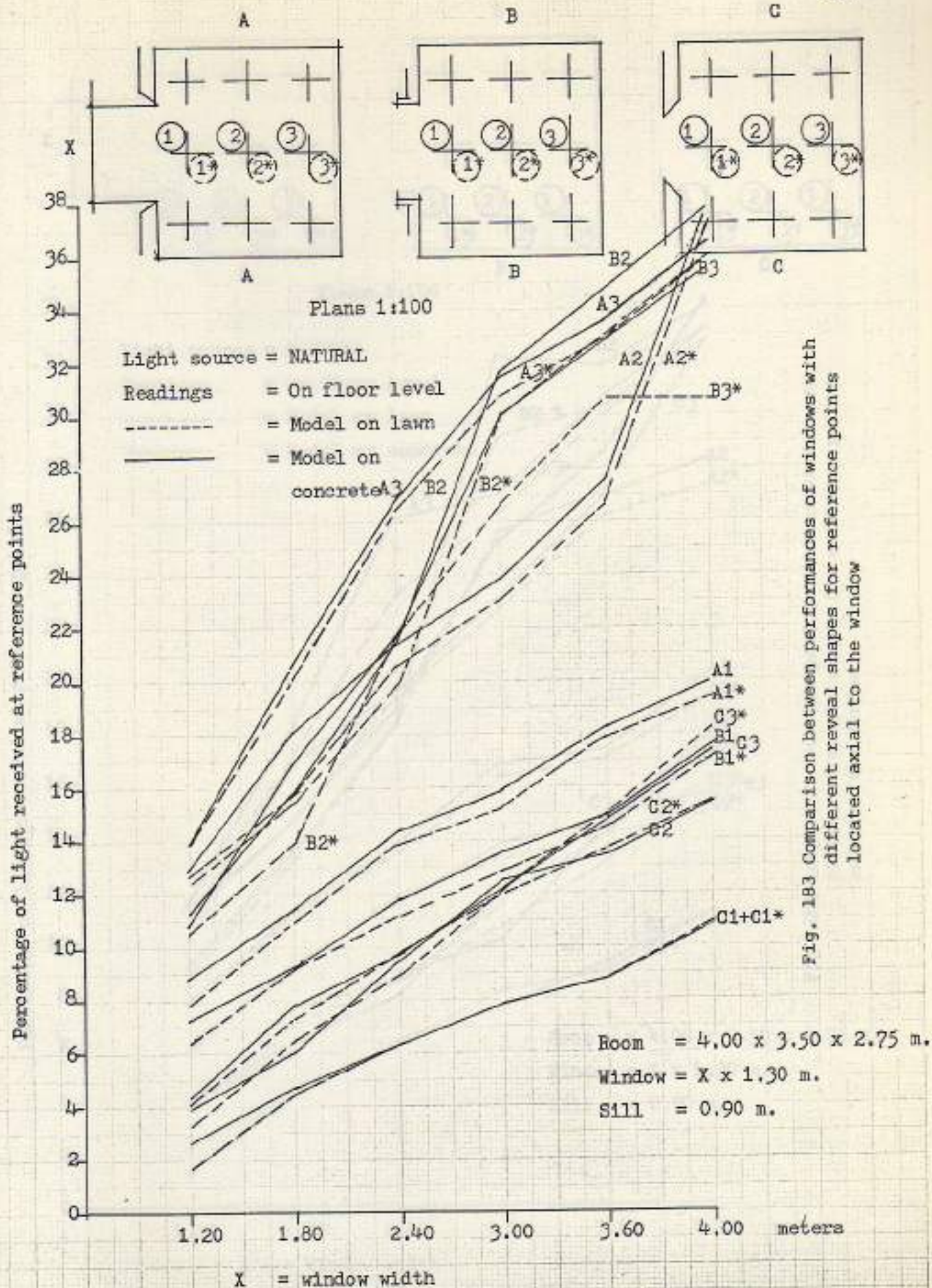
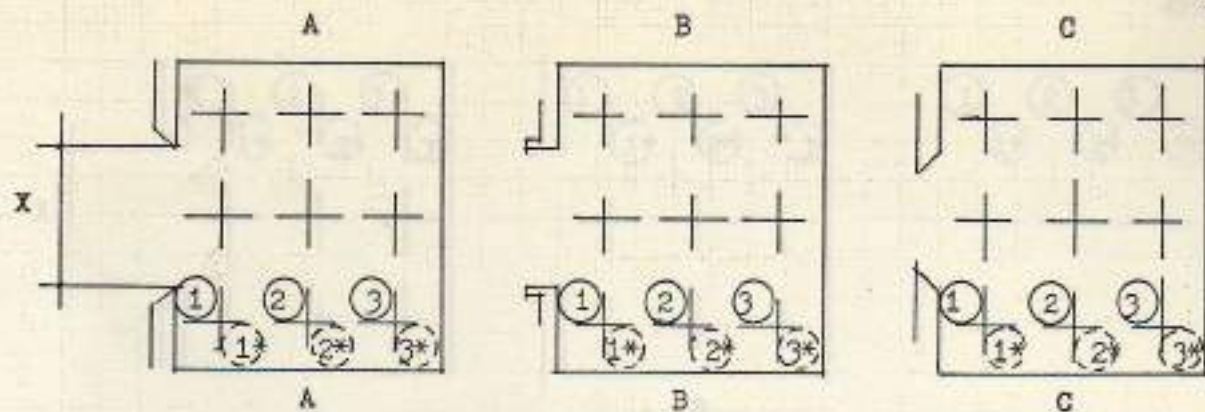

Fig. 182 Comparison between performances of windows with different reveal shapes for selected reference points

Room = 4.00 x 3.50 x 2.75 m.
 Window = X x 1.30 m.
 Sill = 0.90 m.





Plans 1:100

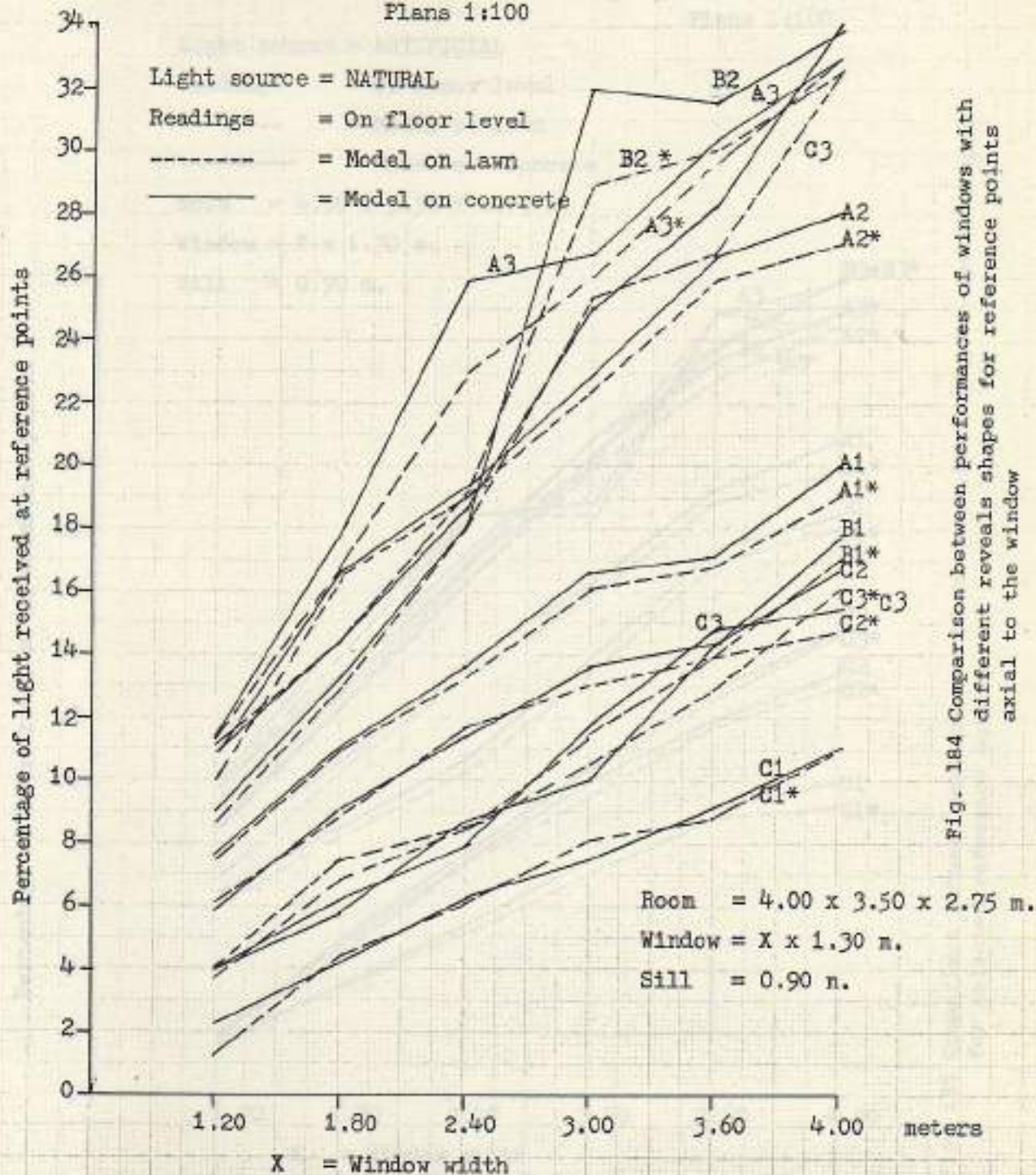
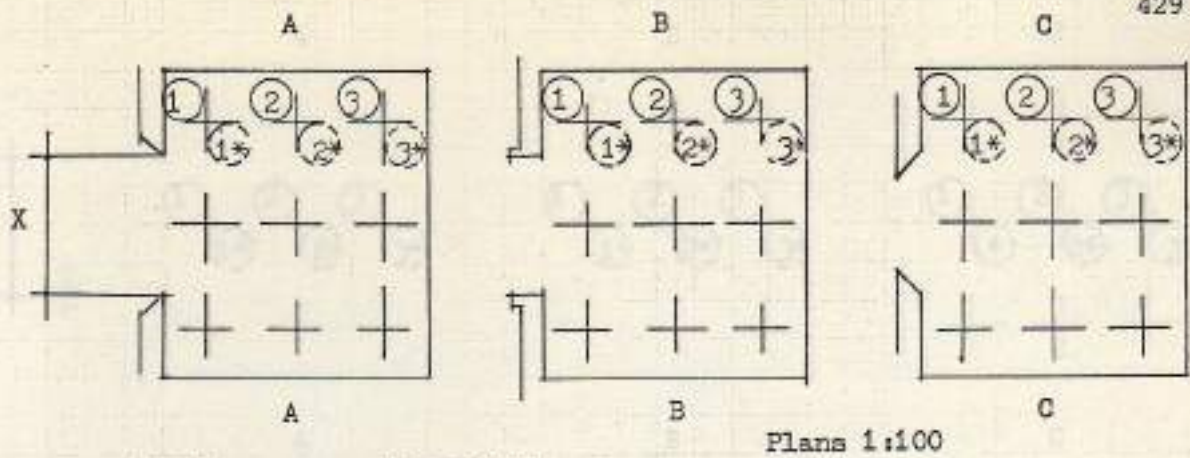

Fig. 184 Comparison between performances of windows with different reveals shapes for reference points axial to the window



Light source = ARTIFICIAL

Readings = On floor level

----- = Model on lawn

————— = Model on concrete

R_{room} = 4.00 x 3.50 x 2.75 m.

Window = X x 1.30 m.

Sill = 0.90 m.

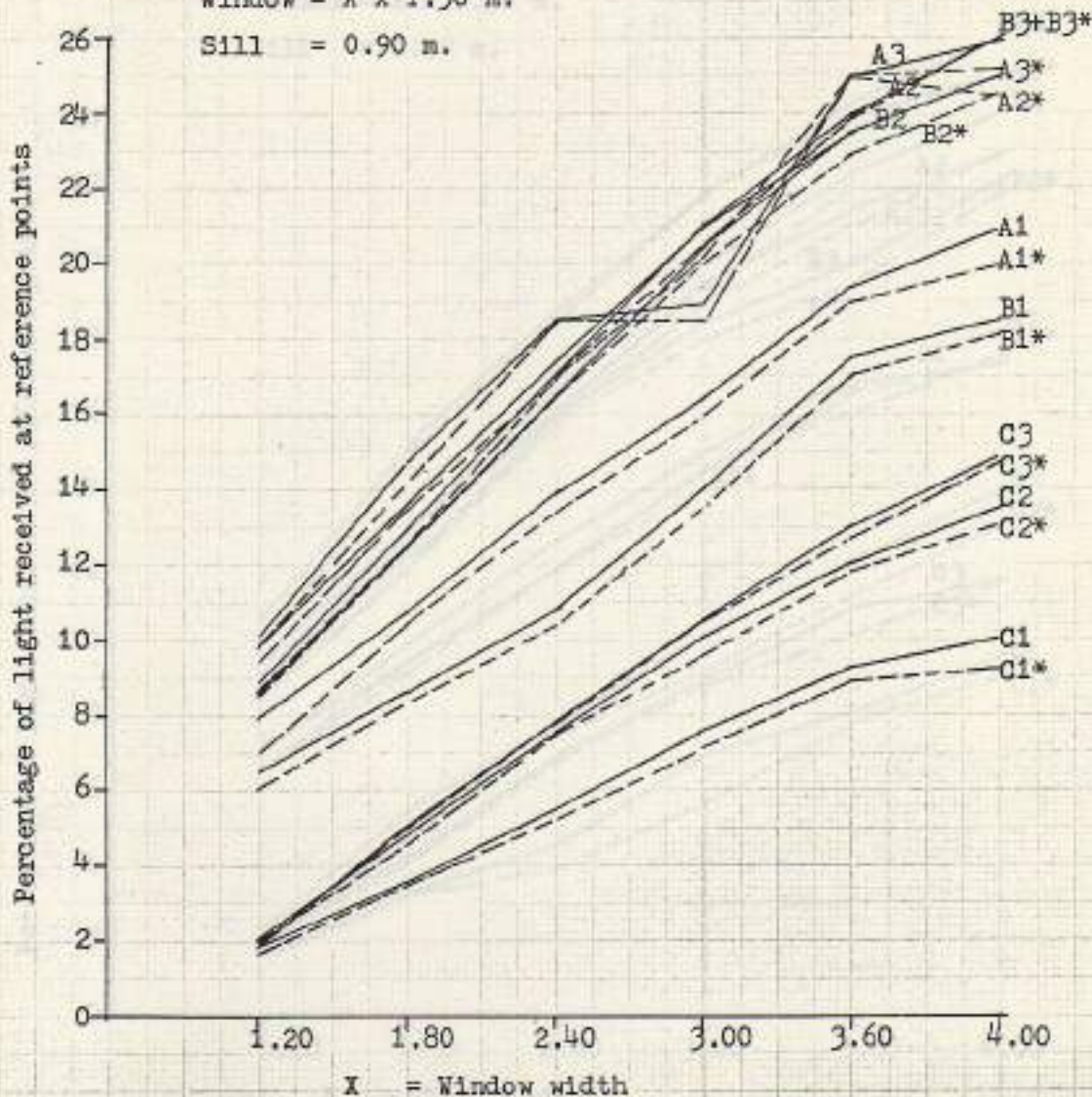
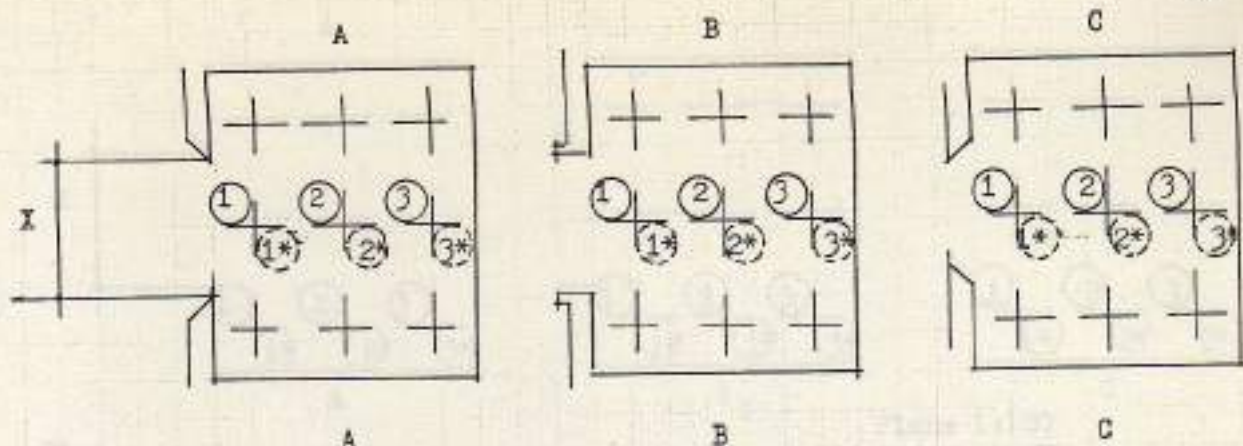

Fig. 185 Comparison between performances of windows with different reveal shapes for selected reference points



Light source = ARTIFICIAL

Readings = On floor level

----- = Model on lawn

————— = Model on concrete

Room = 4.00 x 3.50 x 2.75 m.

Window = X x 1.30 m.

Sill = 0.90 m.

Plans 1:100

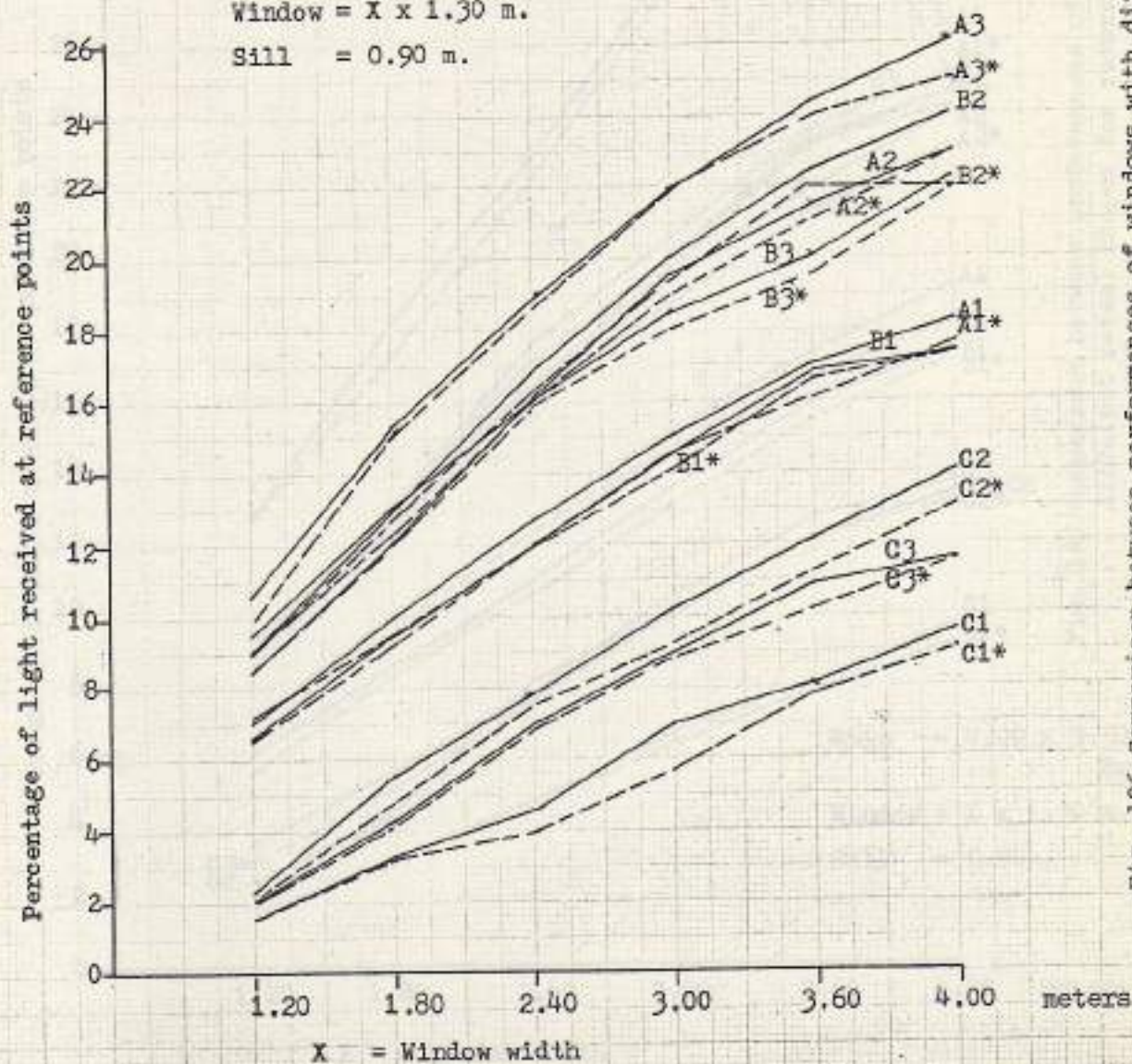
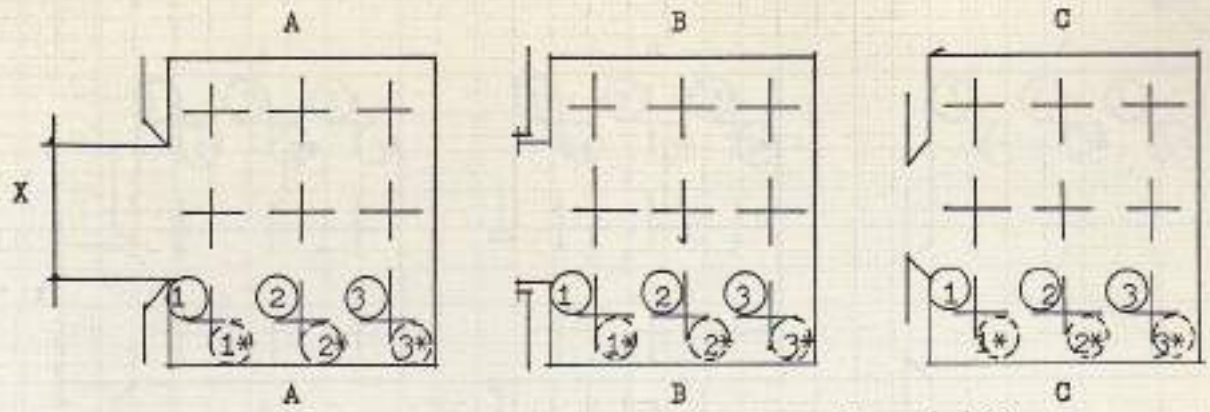

Fig. 186 Comparison between performances of windows with different reveal shapes for reference points axial to the window



Plans 1:100

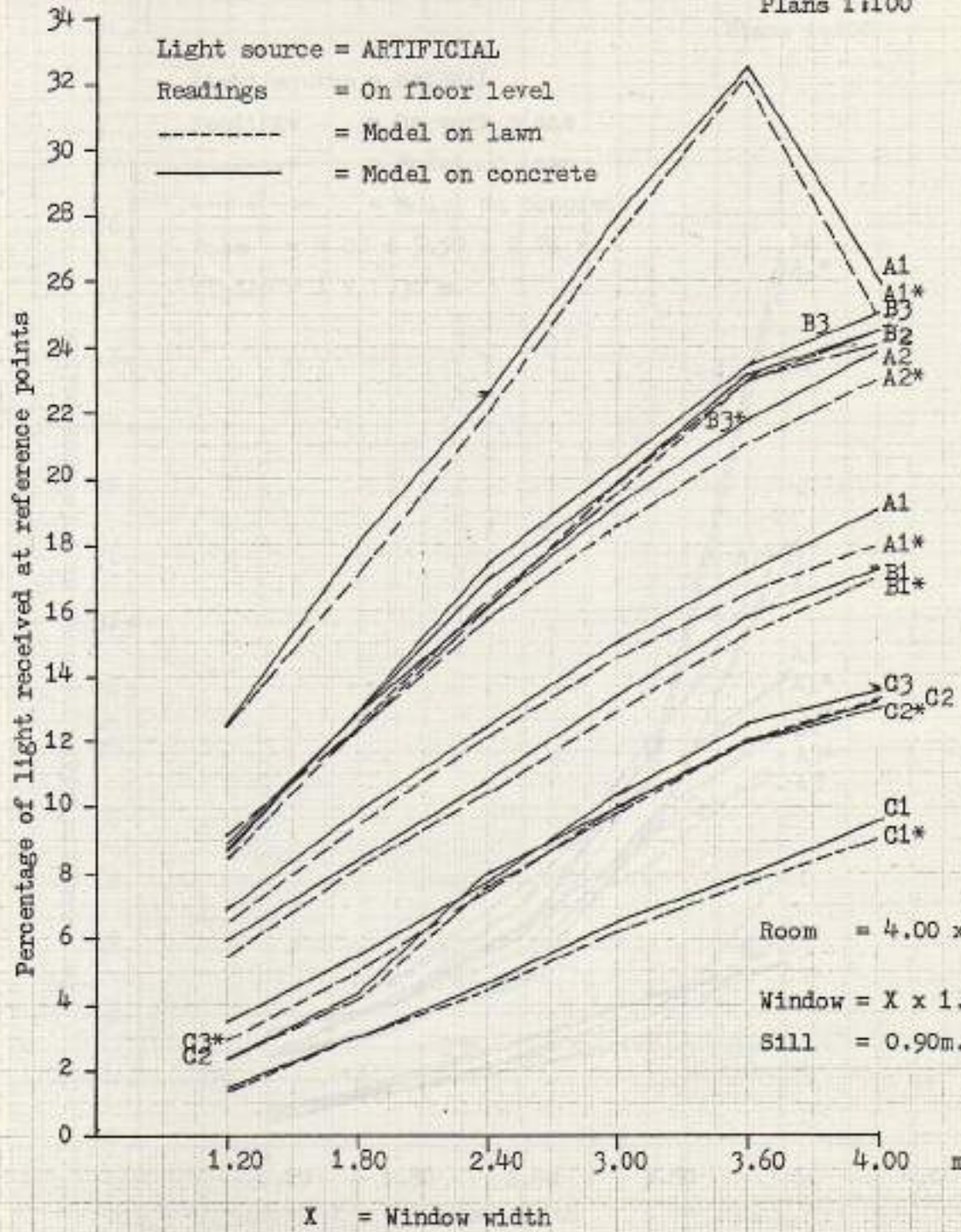
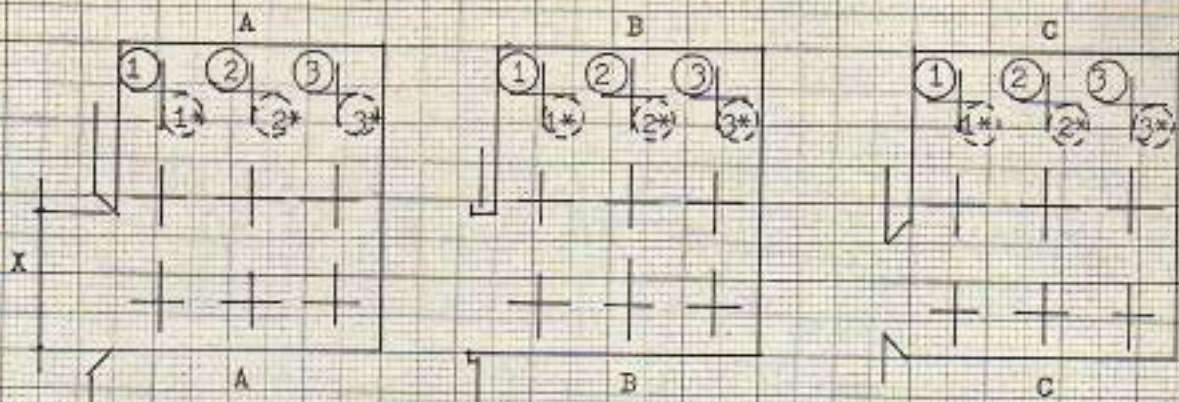

Fig. 187 Comparison between performances of windows with different reveal shapes for reference points located off-center of the windows

Room = 4.00 x 3.50 x 2.75 Meters
 Window = X x 1.30 m.
 Sill = 0.90m.

X = Window width



Plans 1:100

Light source = NATURAL
 Readings = On work plane
 - - - - - = Model on lawn
 ———— = Model on concrete
 Room = 4.00 x 3.50 x 2.75 m.
 Window = X x 1.30 m.

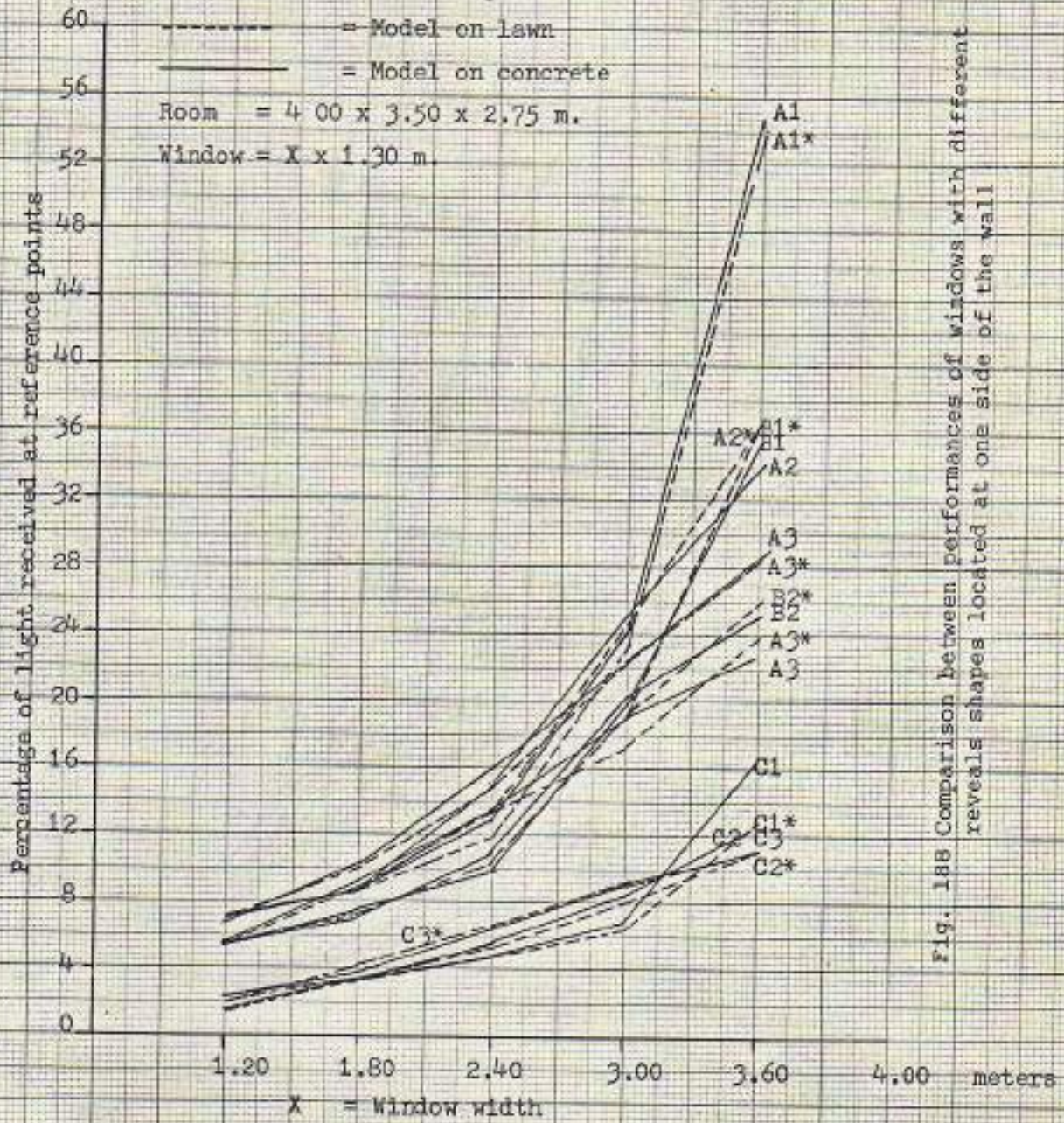

Fig. 188 Comparison between performances of windows with different reveals shapes located at one side of the wall

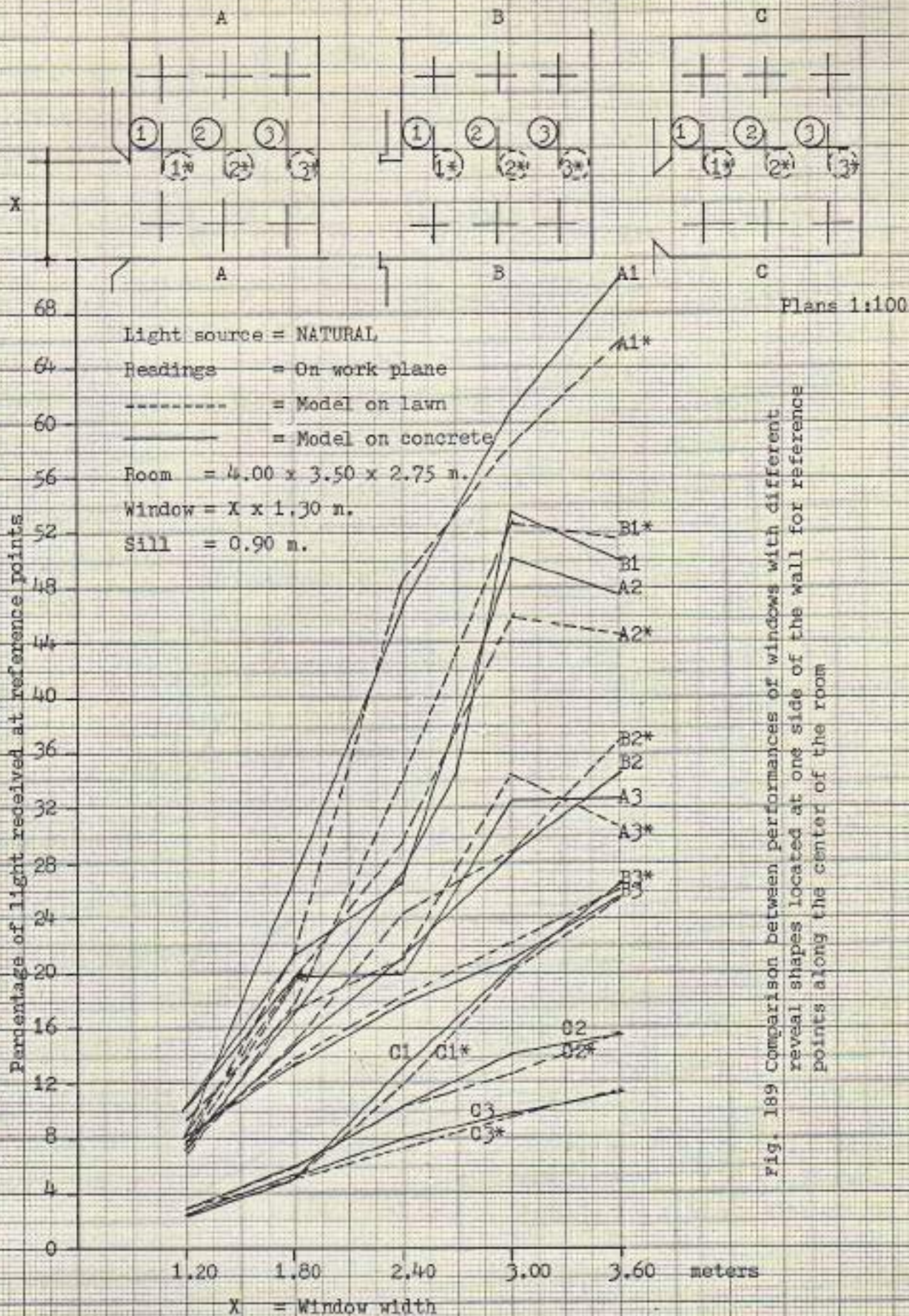

Fig. 189 Comparison between performances of windows with different reveal shapes located at one side of the wall for reference points along the center of the room

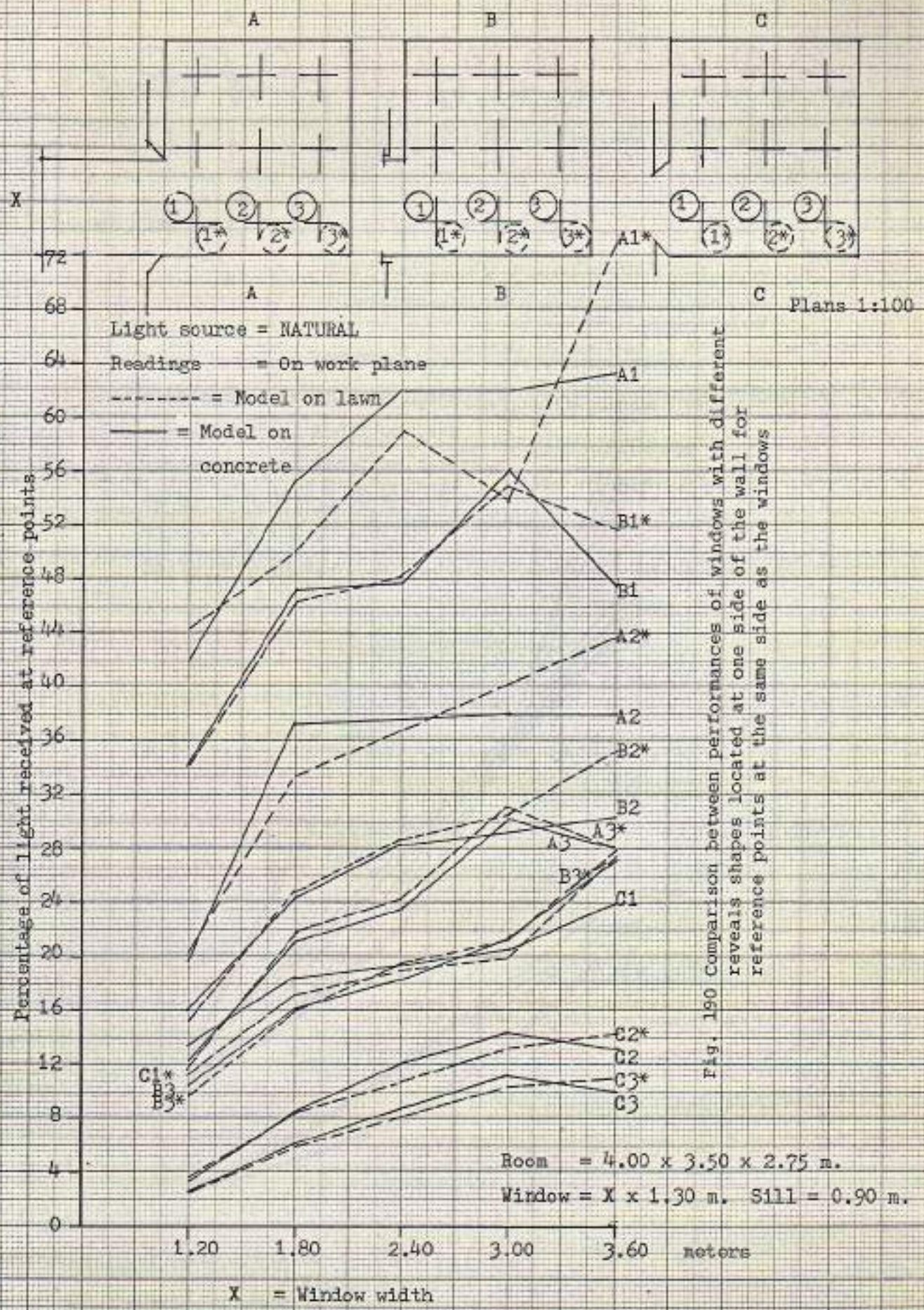

Fig. 190 Comparison between performances of windows with different reveals shapes located at one side of the wall for reference points at the same side as the windows

VERNON WEMILLAN, INC., ELIZABETH, N.J. 07208

No. 19-0810 (P. 2470 10-C) 10 Millimeters to a Centimeter • Made in U.S.A.

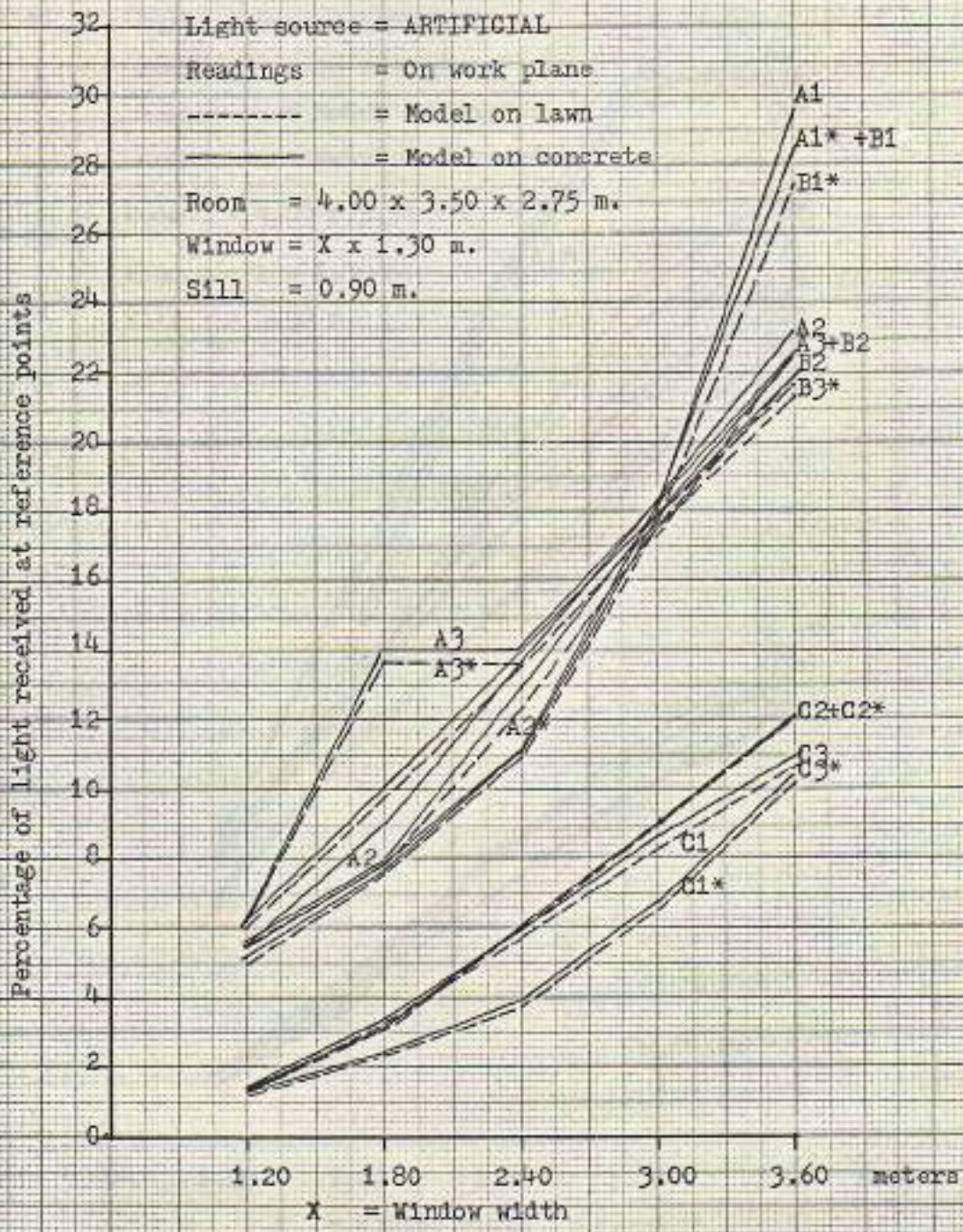
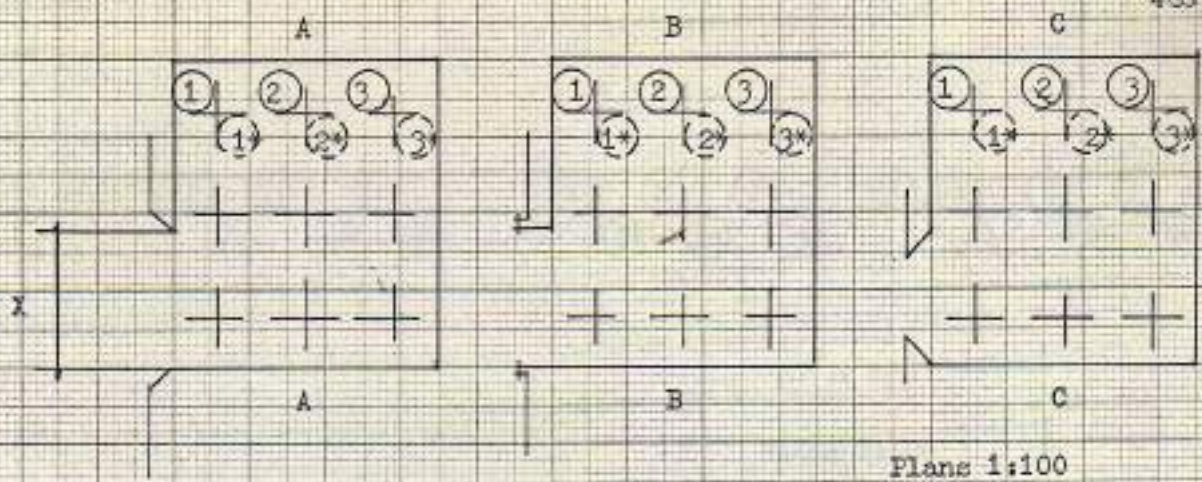

Fig. 191 Comparison between performances of windows having different reveal shapes located at one side of the wall for selected reference points

No. 19-20-50 (11-2470) © C. E. McMillan & Co. Inc. 1950
 McMillan, Inc., ELIZABETH, N. J. 07208

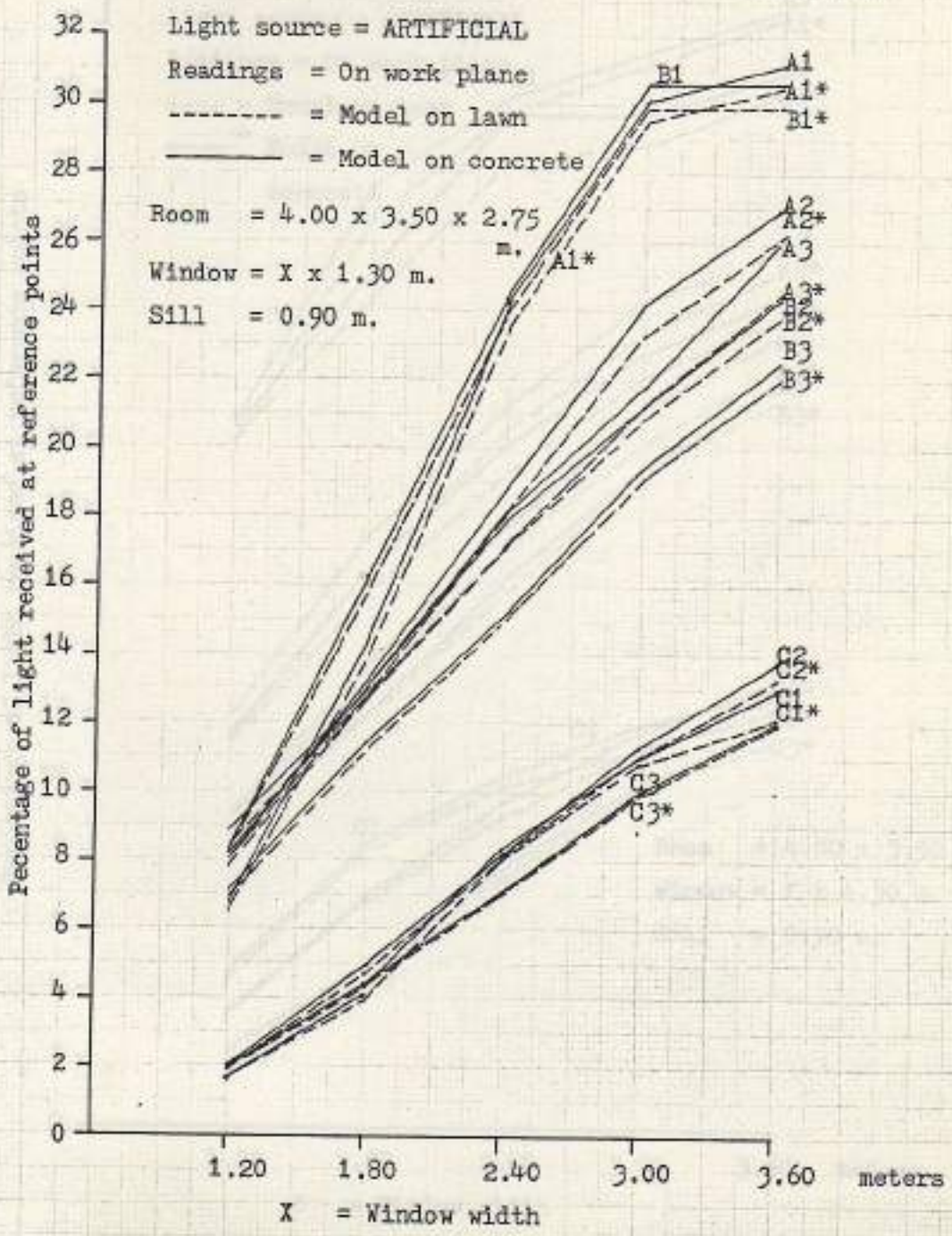
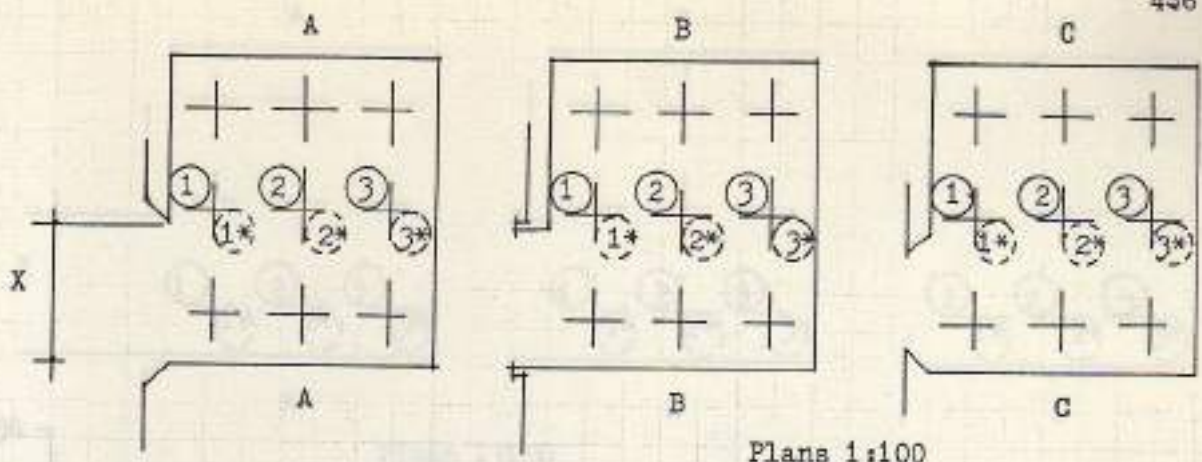

Fig. 192 Comparison between performances of windows with different reveal shapes located at one side of the wall for reference points along the center of the room

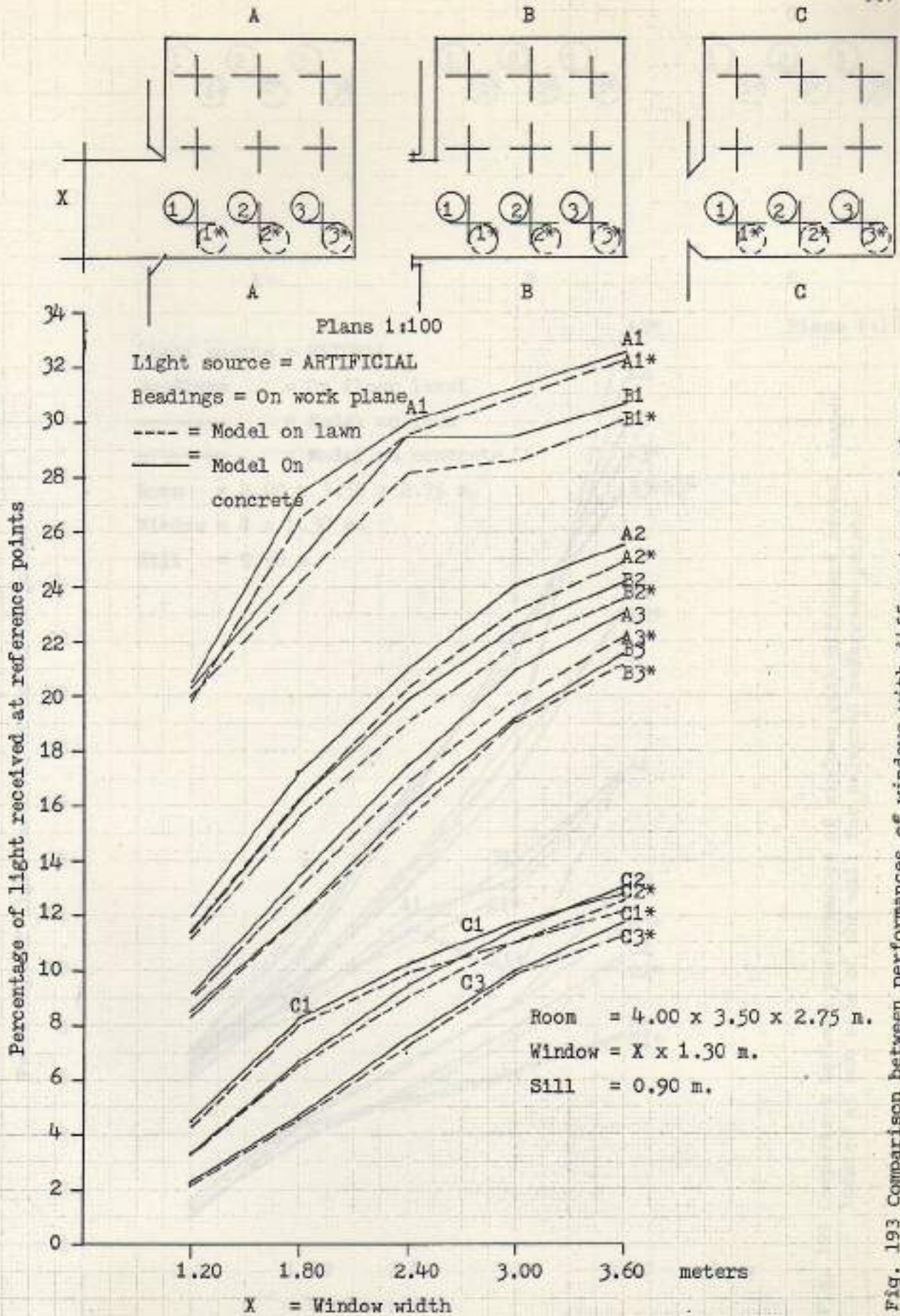

Fig. 193 Comparison between performances of windows with different reveal shapes located at one side of the wall for reference points on the same side

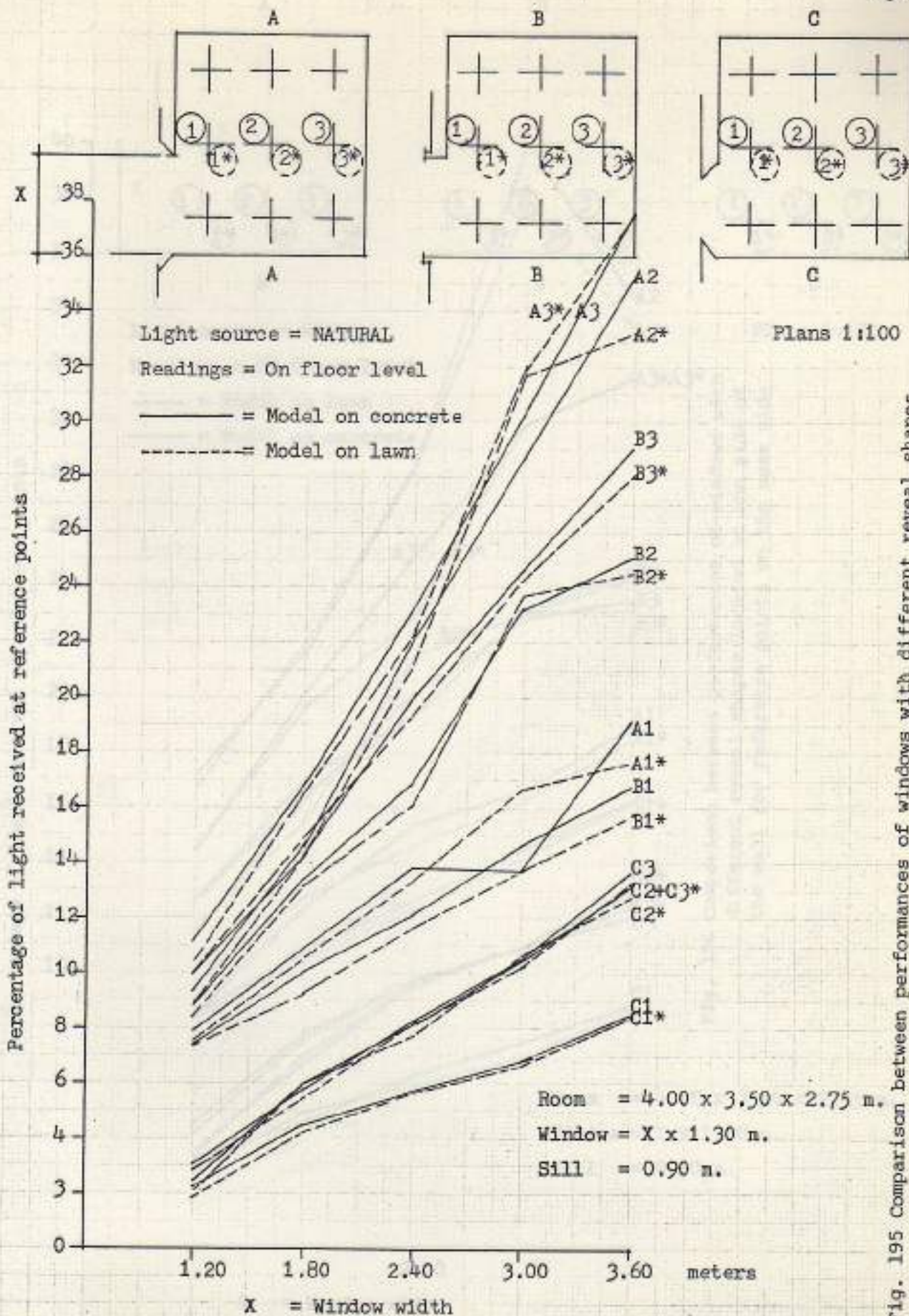

Fig. 195 Comparison between performances of windows with different reveal shapes located at one side of the wall for reference points along the center of the room

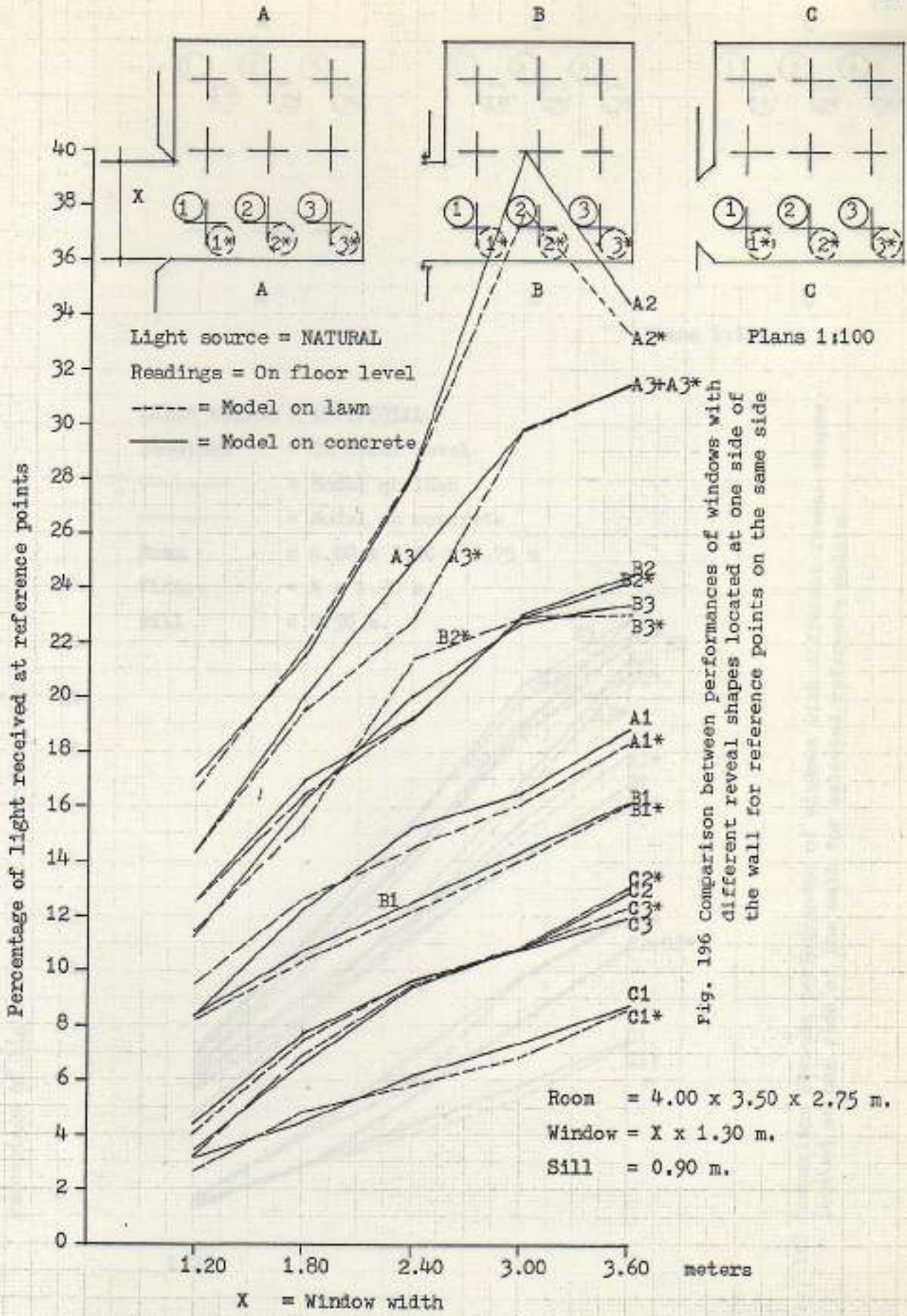
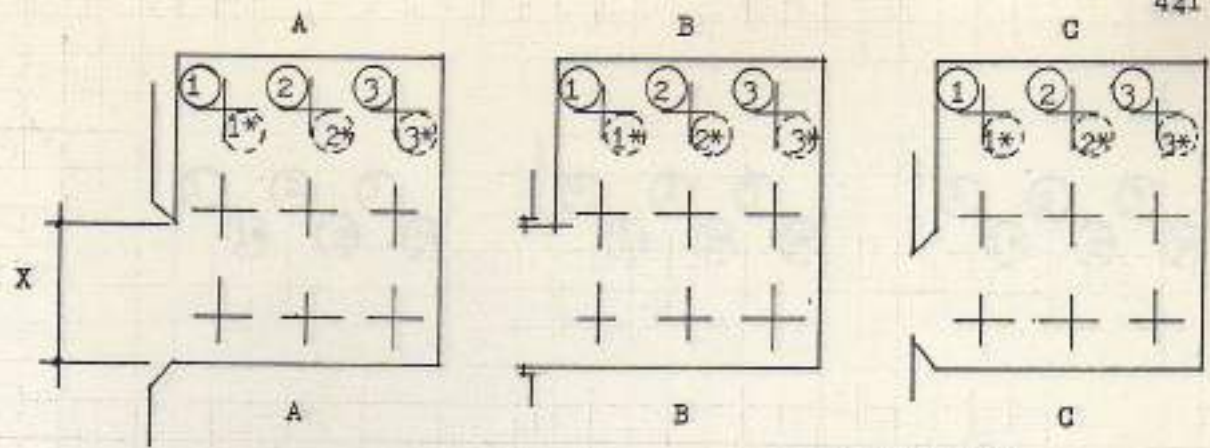

Fig. 196 Comparison between performances of windows with different reveal shapes located at one side of the wall for reference points on the same side



Light source = ARTIFICIAL
 Readings = On floor level
 ----- = Model on lawn
 _____ = Model on concrete
 Room = 4.00 x 3.50 x 2.75 m
 Window = X x 1.30 m.
 Sill = 0.90 m.

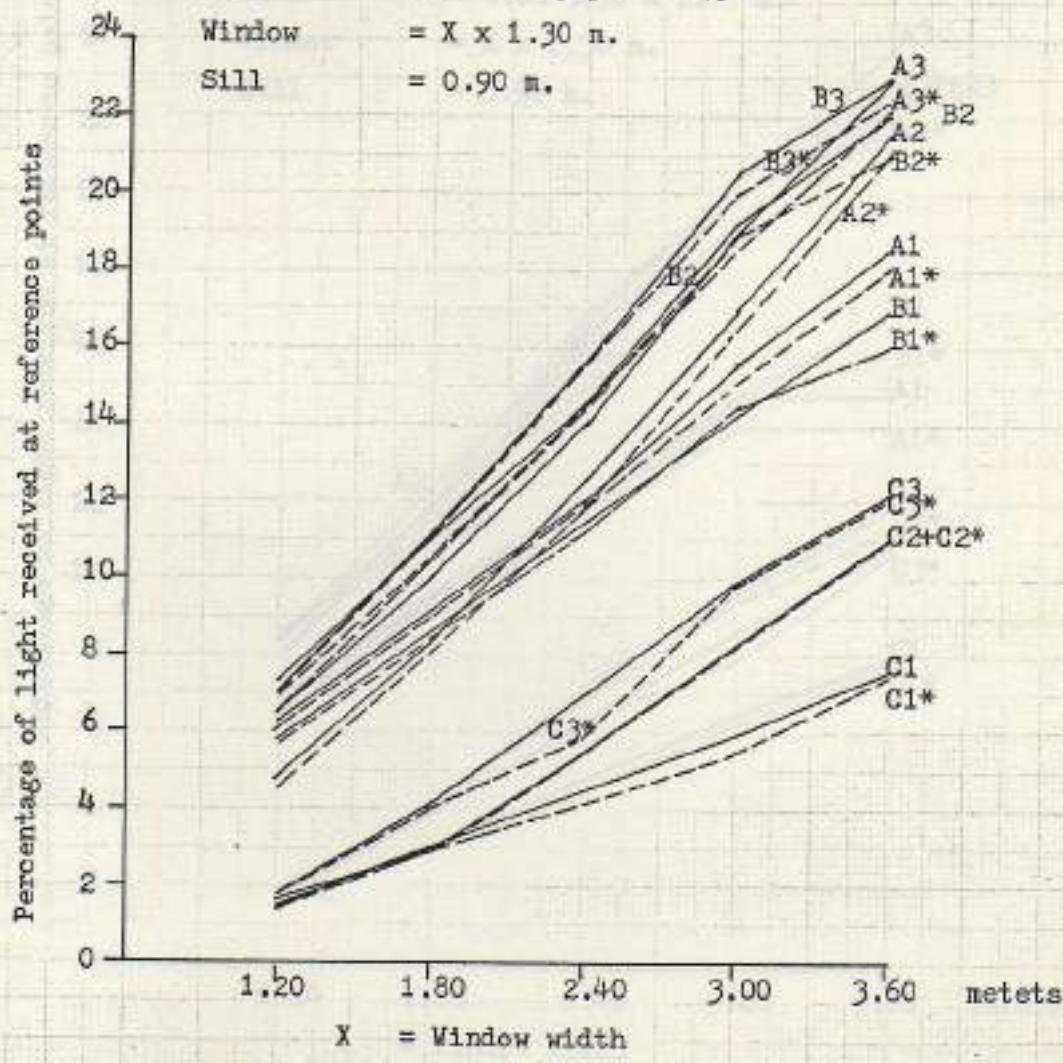

Fig. 197 Comparison between performances of windows with different reveal shapes located at one side of the wall for selected reference points

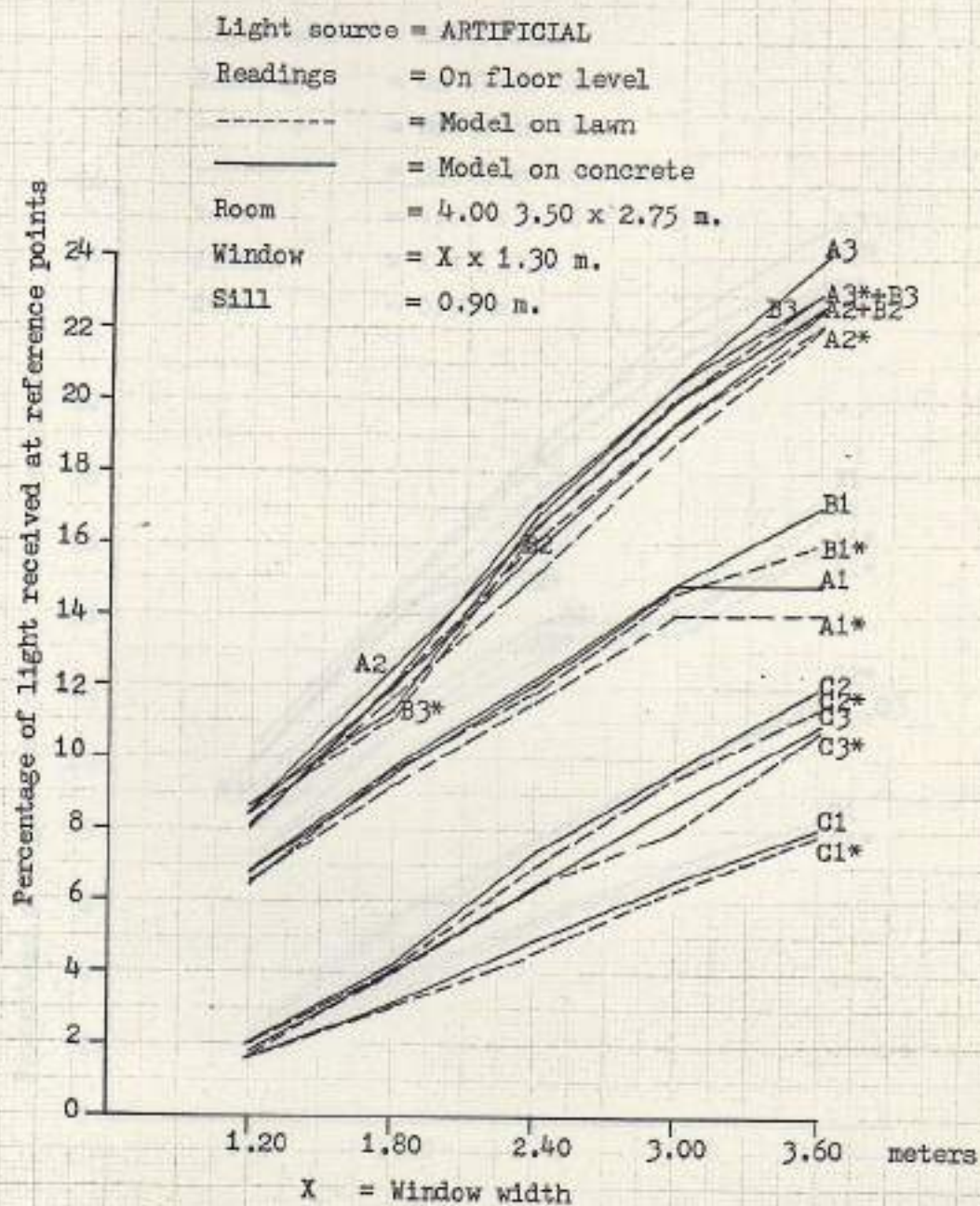
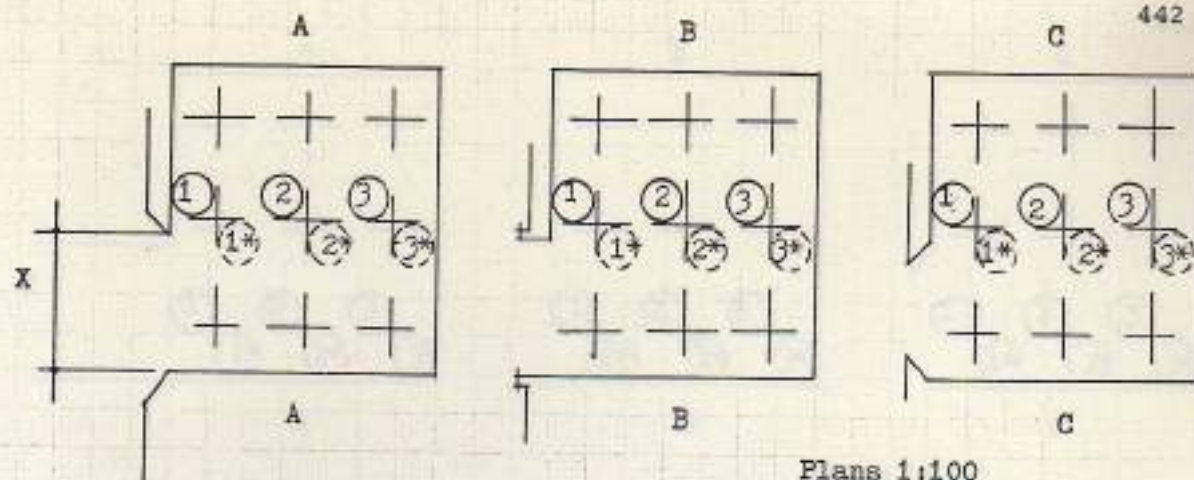

Fig. 198 Comparison between performances of windows with different reveal shapes located at one side of the wall for reference points along the center of the room

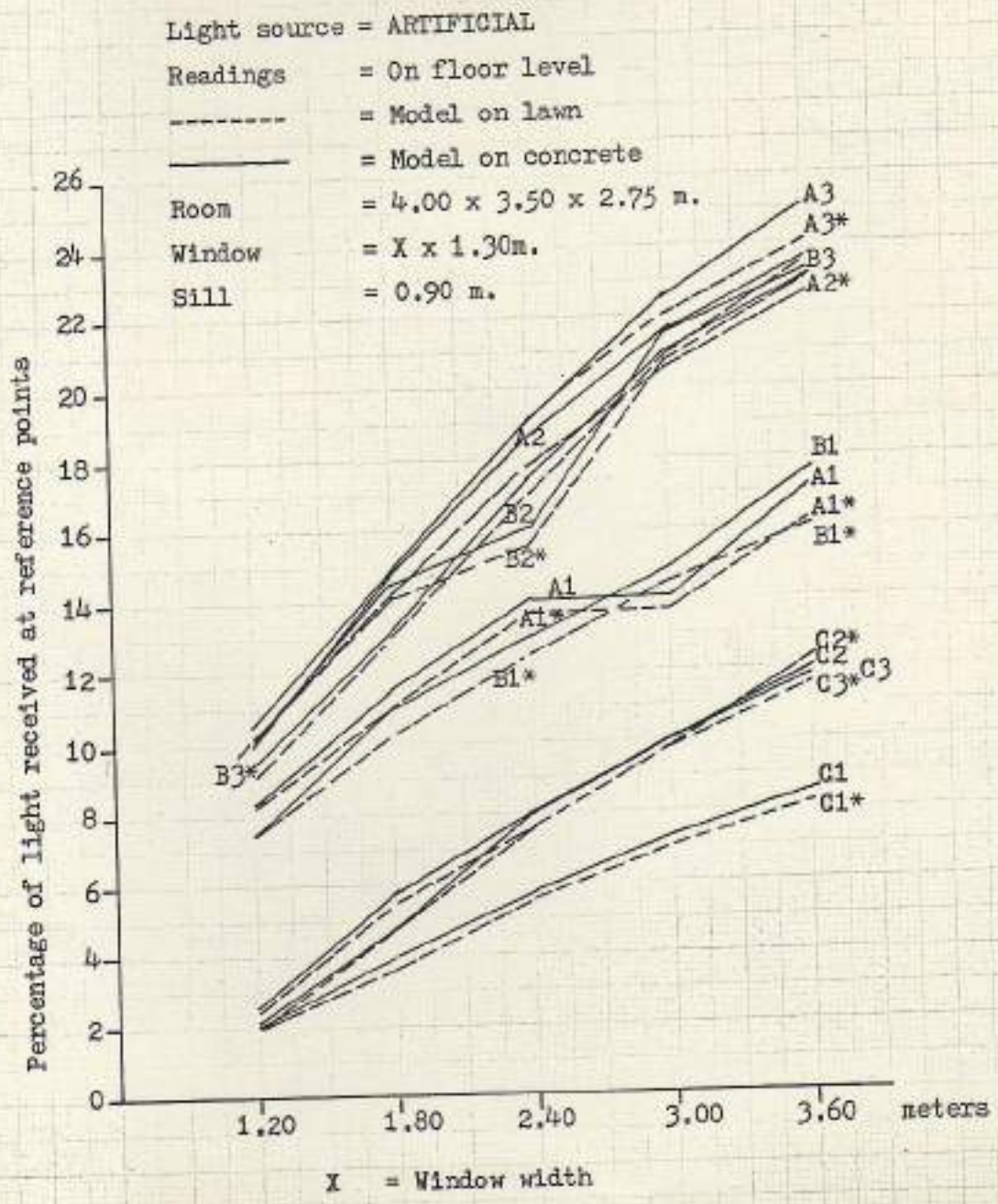
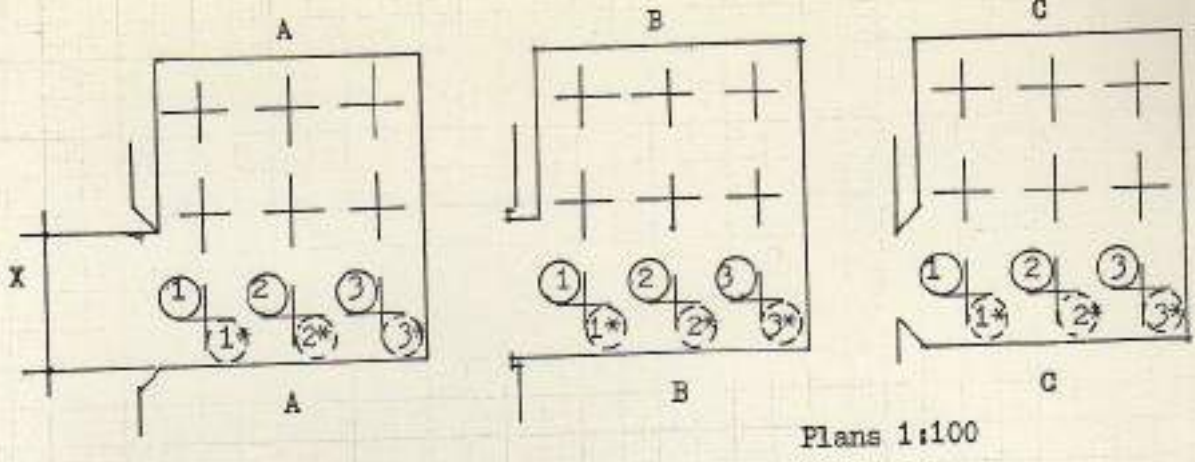

Fig. 199 Comparison between performances of windows with different reveal shapes located at one side of the wall for reference points on the same side

