

PAPER • OPEN ACCESS

Lattice windows as a natural ventilation strategy in hot, humid regions

To cite this article: Mustafa M. Elwan and Hosni A. Dewair 2019 *IOP Conf. Ser.: Earth Environ. Sci.* **397** 012022

View the [article online](#) for updates and enhancements.

Lattice windows as a natural ventilation strategy in hot, humid regions

Mustafa M. Elwan¹, Hosni A. Dewair¹

¹Assistant Professor, Architecture Engineering department, Tanta University, Egypt

E-mail: mustafa.elwan@f-eng.tanta.edu.eg

Abstract. These paper concerns the role of lattice windows in enhancing resident's expectation of comfort ventilation in such places, especially unconditioned buildings which higher air speed is an important strategy to minimize discomfort from high temperature and humidity, especially that some architectural requirements like privacy call for placing openings in certain places that could lead to a poor ventilation in this occupied zone, unless air flow is directed by using some architecture elements in a desired direction by using special inlet opening like lattice windows.

A model room used in Computational fluid dynamics CFD simulation program Ansys Fluent version,14.5 to figure out how lattice window delivers nature ventilation, Windows geometry, wing walls and side windows were observed how they affect wind direction and pressure difference to figure out its impact on room ventilation, A field measurement study in multi-story building with lattice windows were made by using Nova-Lynx weather station to observe internal ventilation speed and distribution with synchronous external wind.

Keywords: lattice window, natural ventilation, CFD, comfort ventilation, wing wall.

1. Introduction

Researches has reviewed the effect of acclimatization and standard of living on comfort sensations and expectations in residential buildings in hot developing countries, such as ([1]Webb 1959, [2]Nicol 1974, [3]Humphreys 1975, and Tanabe 1988), These studies explained that people accept a rise in temperature as a local average annual temperature[4].

comfort ventilation by introducing air through openings provides a physiological cooling effect due to increasing sweat evaporating from skin in hot, humid regions therefor even the indoor temperature is elevated by incoming warm air through opening the upper temperature limit is shifted because of achieving comfort due to higher air

[1] Webb, C. G. 1959. "An Analysis of Some Observations of Thermal Comfort in an Equatorial Climate." British J. Industrial Medicine, V-16, pp. 297-310.

[2] Nicol, J. F. 1974. "An Analysis of Some Observations of Thermal Comfort in Roorkee, India and Baghdad, Iraq." Annals of Human Biology, V—1, pp. 411-426.

[3] Humphreys, M. A. 1975. "Field Studies of 'Thermal Comfort Compared and Applied.'" Building Research Establishment, Current Paper. CP 76/75, UK: Garston, Watford.

[4] Givoni, B. Basic Study of Ventilation Problems in Housing in Hot Countries. 1962. Building. Man, Climate and Architecture. 2nd ed. 1976. London; Applied Science Publishers;



speed according to comfort aspects of climatic applicability's such delineation of boundaries could reduce using mechanical devices to achieve comfort ventilation.

Comfort standards, such as ASHRAE used extensively as a base of structuring bioclimatic charts, the lowest air speed in ASHRAE Guide is 0.15 m/s in winter and 0.25 m/s in summer, and highest air speed is 0.8 m/s at temperature of 28°C.

People who live in naturally ventilated buildings usually get such a wider range of air speeds, it is often between 1 to 2 m/s this high ventilation rate tends to approach outdoor temperature level especially during the evening and night hours.

Ventilation comfort is a common strategy in warm, humid regions, relying on air speed over human body, which could be increased by opening windows for natural ventilation. Providing higher indoor air speed prevents elevation of indoor vapor content of air, [5].

The rate of air flow through a naturally ventilated building depends on wind conditions and design details of this building, geometrical configuration of the building's envelope, Location of openings, Total area of openings in the pressure and suction, Type of windows and Presence or absence of fly screens like opening with set of diagonally crossing strips of wood or metal arranged to form a pattern that called lattice windows.



Fig. 1 Lattice Window- House of Egyptian Architecture-Cairo-Egypt

distribution of air velocities and overall amount of airflow should be considered in evaluating Indoor Ventilation throughout the ventilated space in such Criteria based on several conditions: -

- Air speed at inlet opening.
- Maximum speed at any point in the space.
- Average air speed in space.
- Average speed at occupancy level.

Existence of porches projecting outward or recessed inward affect the pressure distribution along facades as well as openings, buildings exposed to oblique winds with angles of 30 to 60° away from the normal, can provide better ventilation conditions in individual rooms, When the wind is oblique to the building a pressure gradient is created along the windward walls, If two windows are provided in a given room along the windward wall the upwind window is at a higher pressure than the downwind one, Thus air enters the room through the upwind

[5] Givoni, B. 1983a. "Review of Passive Heating and Cooling Research." PLEA '93, Oxford: Pergamon Press, pp. 339-352.

window and leaves through the downwind aperture but When the wind is perpendicular to the wall, the two openings are exposed to the same pressure and this reduces the ventilation of the room.

If such a wing wall is placed downwind of the first window, high pressure is created in front of it. A wing wall upwind of the second window creates a suction in front of it.

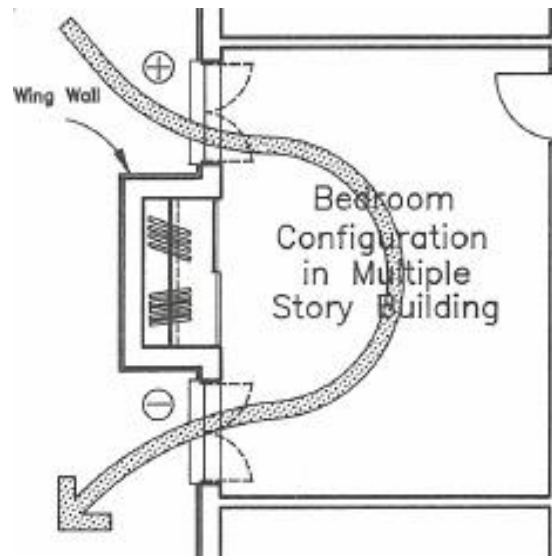

Fig. 2 architecture features acting as wing walls [6].

performance of wing walls was studied by S. Chandra et al. (1983) at Florida Solar Energy Center, both in models and in a full-scale experimental building and the effectiveness of the wing walls was verified in both cases.

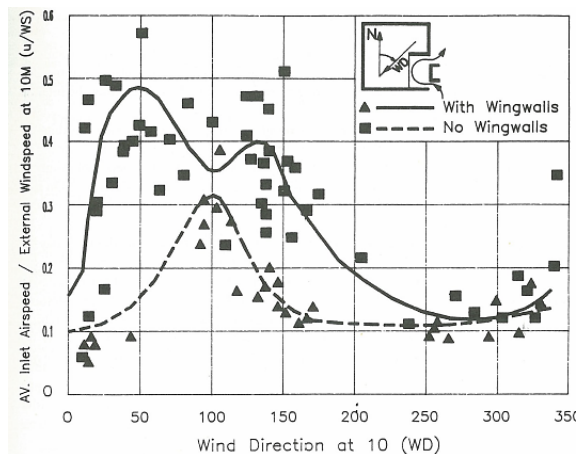

Fig. 3 Effect of wing walls on indoor air speed (data form Chandra et al (1983)) [6].

Pressure differences can be created also by such design elements as rooms projecting slightly from the main wall or recessed porches or lattice windows.

[6] Givoni, B. Basic Study of Ventilation Problems in Housing in Hot Countries. 1962. Building Research Station Report. Technion-Institute of Technology.



Fig. 4 Lattice Window- House of Egyptian Architecture-Cairo-Egypt

When the window faces an oblique wind, increasing its width provides a pressure gradient and increases indoor air speed.

Small inlets may be suitable in rooms where the place of occupancy is defined and close to inlet window, On the other hand in a room which any spot may be occupied a large inlet would be most suitable.

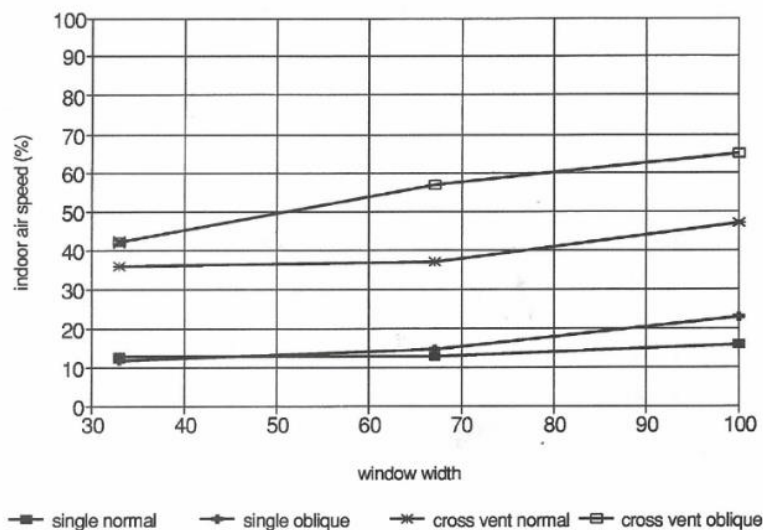

Fig. 5 Effect of window size (width) and wind direction (normal or oblique to the wall) on indoor air speed [6].

Some architectural requirements like privacy call for placing openings near ceiling high above level of occupancy so there is a sharp drop in air speed at vertical levels below inlet window, and poor ventilation conditions may exist in this occupied zone unless air flow is directed downward by using some architecture elements to direct the airflow in any desired direction by designing special inlet opening details like ornament

lattice windows.

Different Window Types producing multiple patterns of indoor airflow when serving as inlets and providing different options for controlling direction and speed of air flow.

Some window elements like fly screens reduces airflow rate, so in order to reduce this interference with ventilation it is recommended to increase area of fly screen much greater than the area of the opening itself like placing fly screen over a porch in front of the openings to reduce airflow interference.

Series of experiments was conducted with models in a wind tunnel by Givoni (1968), The models had one outlet and one inlet opening at the center of the walls. The area of the inlets and outlets were identical one-ninth of the area of walls, the following conditions were tested to show that putting fly screens in front of balconies instead of windows reduced the interference of the screens with the air flow.

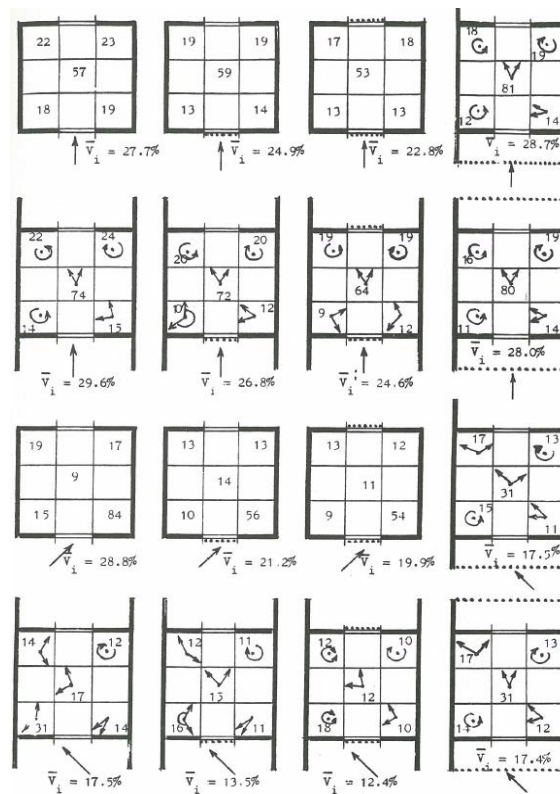

Fig. 6 Effect of fly screens on indoor air speed ⁶

2. Methodology

A computational fluid dynamics software package program ANSYS Fluent version 14.5 used to simulate natural ventilation in a model room with dimension of 3.75 X 3.75m width and 3.00 m high, the model geometry assumed to be a three-dimensional domain generated by using AutoCAD drawing program version 2016 and added to ANSYS Fluent software.

The simulation assumed a steady state condition and working fluid air K Epsilon turbulence model, continuity and momentum equations were used to obtain air mass behavior, pressure and velocity, the values of inlet wind velocity is 6 m/s and outlet set as atmospheric pressure, Domain walls, roof and floor are assumed smooth.

[6] Givoni, B. Basic Study of Ventilation Problems in Housing in Hot Countries. 1962. Building Research Station Report. Technion-Institute of Technology

A transport model equation for kinetic energy (k) is the base of k - Epsilon model and dissipation rate (ϵ) [7], the flow was assumed fully turbulent, and no effects of molecular viscosity [8]. The standard k - Epsilon model is for fully turbulent air flow [9].

Six architectural cases simulated to present the effect of lattice window elements as shown in Figures, large ornament screen creates a gradient pressure along the windward walls by redirecting normal wind to oblique as shown in figures from 8 to 13, also large area of lattice window allows to reduce the interference of the ornament screens with the air flow, side windows of lattice window create a lateral air movements beside walls, and Prominent element in lattice window is placed downwind to create a high pressure in front of it and the other upwind side creates a negative pressure that improve air movement from high pressure to low pressure which allows wind to reach deeper into room space as shown in figures from 10 to 23.

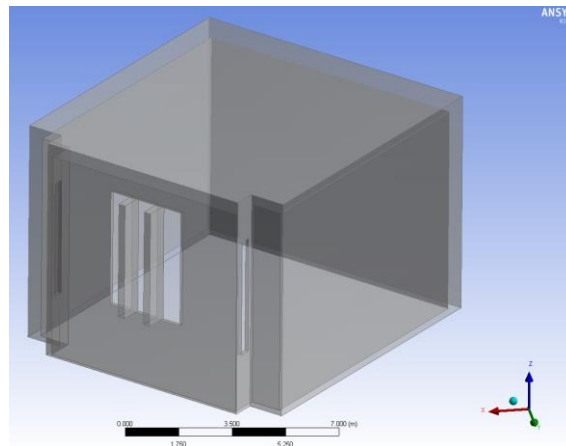

Fig. 7 a three-dimensional model room generated by AutoCAD drawing program version 2016 and added to ANSYS Fluent software version 14.5.

A field measurement study in multi-story building with lattice windows were made by using Nova-Lynx weather station with Ws-25 data logger [10] to observe internal ventilation speed and distribution with synchronous external wind as shown in figures from 7 to 9.

[7] Anderson, D. A., Tannehill, J. c., and Pleather, R. H., 1980 "Computational Fluid Mechanics and Heat Transfer" Hemisphere.

[8] Harlow, F. H., and Nakayama, P. I., 1967 "Turbulent Transport Equations" Physics of Fluids, 10, 323.

[9] Jones, W. P., and Launder, B. E., 1972 "The Prediction of Laminarization With a Two-Equation Model of Turbulence" Int. J. Heat Mass Transfer, Vol. 15, 301-314

[10]<https://novalynx.com/store/pc/110-WS-25-Modular-Weather-Stations-p1073.htm>



Fig. 8 a multi-story building with lattice windows-Tanta university, Egypt



Fig. 9 indoor measurement by Nova-Lynx weather station

3. Results

In order to figure out how lattice window affects internal ventilation, an ordinary single sided ventilation model room of dimension 3.75 X 3.75m width and 3.00 m high with single opening 1.00m width and 1.60 m high was exposed to normal air with velocity of 6 m/s, a contour of air speed result explained that there is no air movement inside room due to exposed normal air.

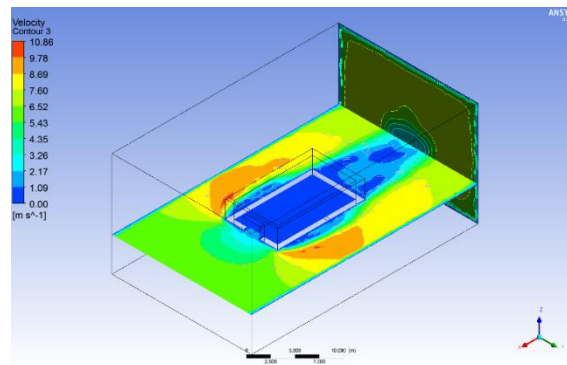

Fig. 10 single ventilated sided room exposed to normal wind of 6/m air velocity.



Fig. 11 A contour section shows that no air movement inside room.

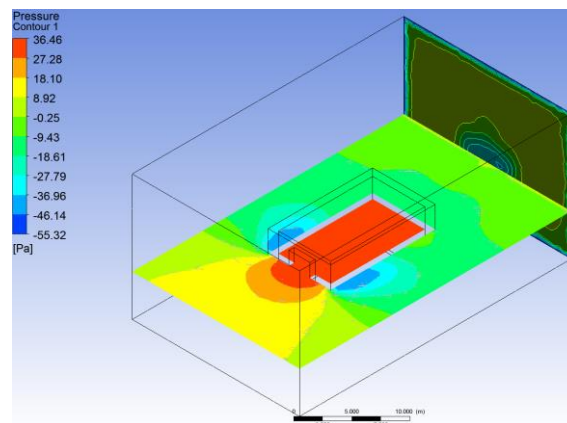

Fig. 12 normal wind crates a uniform high pressure inside room space prevents wind movement inside room.

Experiment shows that a Regular plain opening of a single ventilated sided room of dimension 3.75 X 3.75m width and 3.00 m high exposed to normal wind of 6/m air velocity Does not deliver internal ventilation because of normal wind crates a uniform pressure inside room space prevents wind movement.

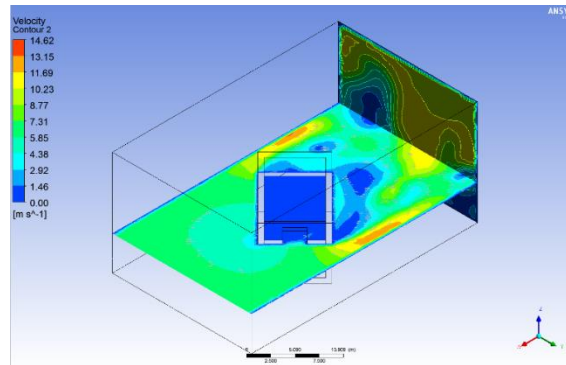

Fig. 13 single ventilated sided room exposed to oblique wind of 6/m air velocity.

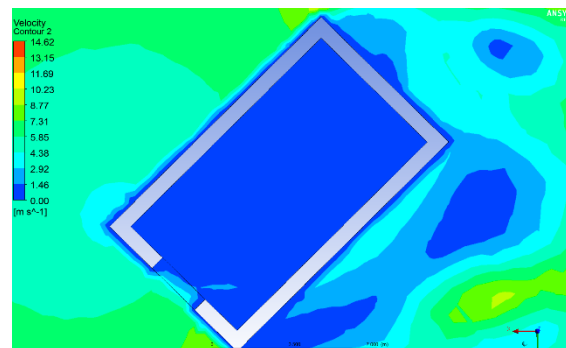

Fig. 14 A contour section shows air movement inside room up to 2.92 m/s due to Oblique wind.

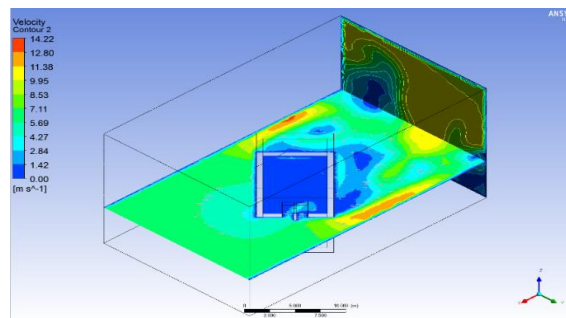

Fig. 15 single ventilated sided room with window wing exposed to oblique wind of 6/m air velocity.

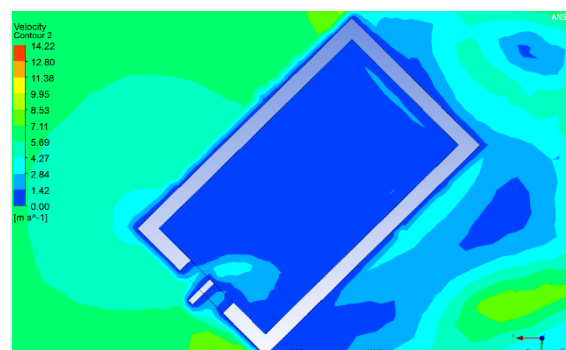

Fig. 16 A contour section shows air movement inside room depth up to 4.27 m/s due to window wing and Oblique wind.

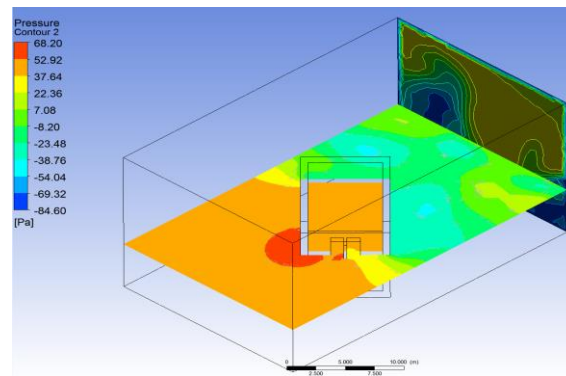

Fig. 17 oblique wind crates a nonuniform pressure that allow wind movement inside room.

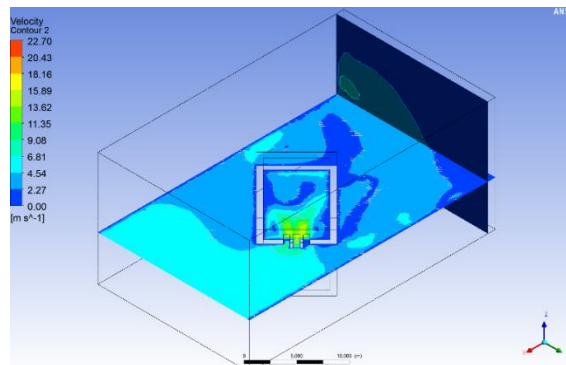

Fig. 18 single sided ventilated room with double window wing exposed to oblique wind of 6/m air velocity.

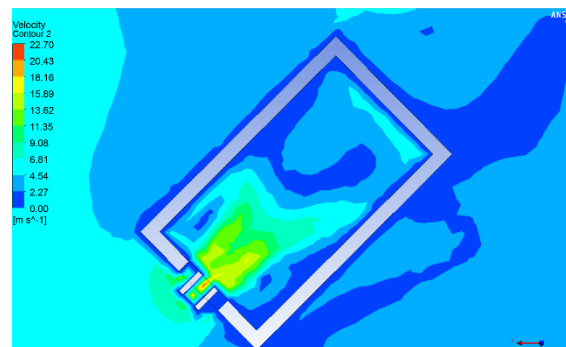

Fig. 19 A contour section shows increasing air movement inside room depth up to 18.16 m/s due to double window wing and Oblique wind.

Experiment shows that exposing oblique wind, as shown in contour section Fig 14 shows that air speed inside room is up to 2.92 m/s due to Oblique wind and it is increased as show in Fig 16 to 4.27 m/s inside room depth due to window wing and Oblique wind that oblique wind crates a nonuniform pressure that allow wind movement inside room as shown in Fig 17, And by doubling wing window, A contour section shows in Fig. 19 increasing air movement inside room depth up to 18.16 m/s .

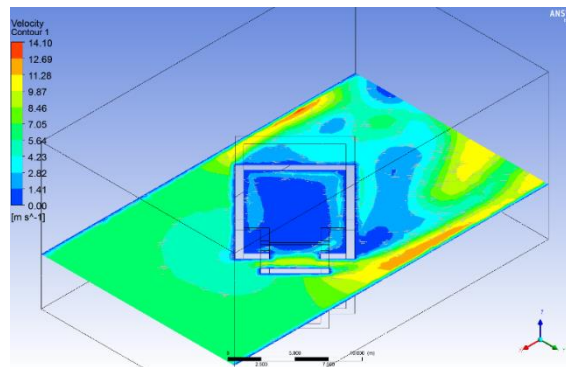

Fig. 20 single sided ventilated room with double side window to oblique wind of 6/m air velocity.

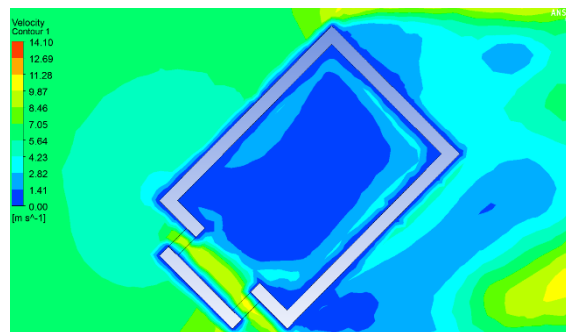

Fig. 21 A contour section shows increasing air movement beside room wall up to 4.23 m/s due to sided windows and Oblique wind.

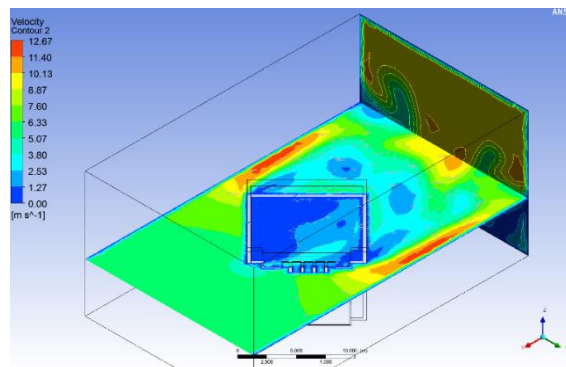

Fig. 22 single sided ventilated room with double side window and multiple wing windows exposed to oblique wind of 6/m air velocity.

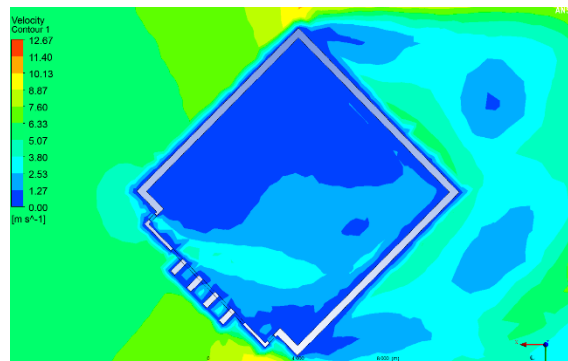

Fig. 23 A contour section shows increasing air movement in room up to 3.8 m/s due to integration between sided windows and multiple window.

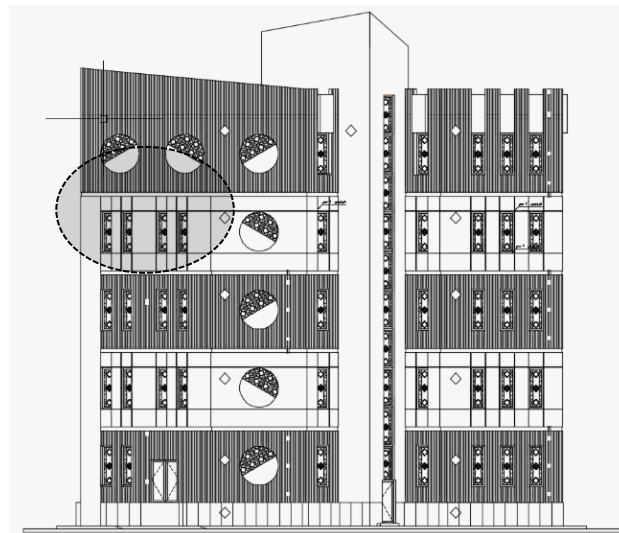

Fig. 24 elevation of a multi-story building-case study- with lattice windows Tanta University, Egypt.

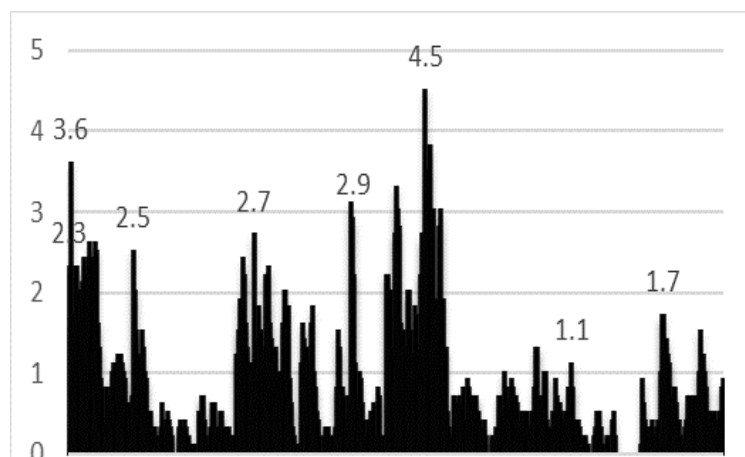

Fig. 25 A sample of air velocity at point Z during 3 minutes before noon.

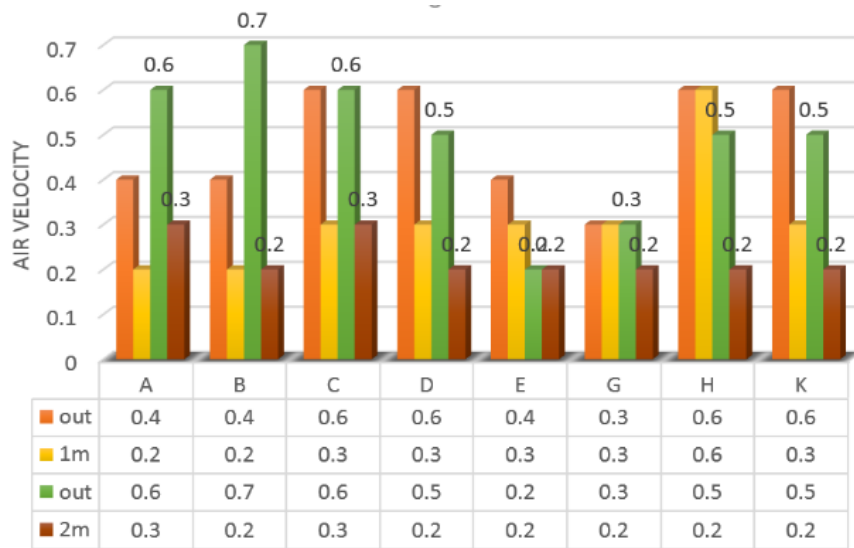

Fig. 26 A diagram of air velocity at points from A: K due to natural ventilation at positions 1 and 2.



Fig. 27 A diagram of air velocity at points from A: K due to natural ventilation at positions 1 and 2.

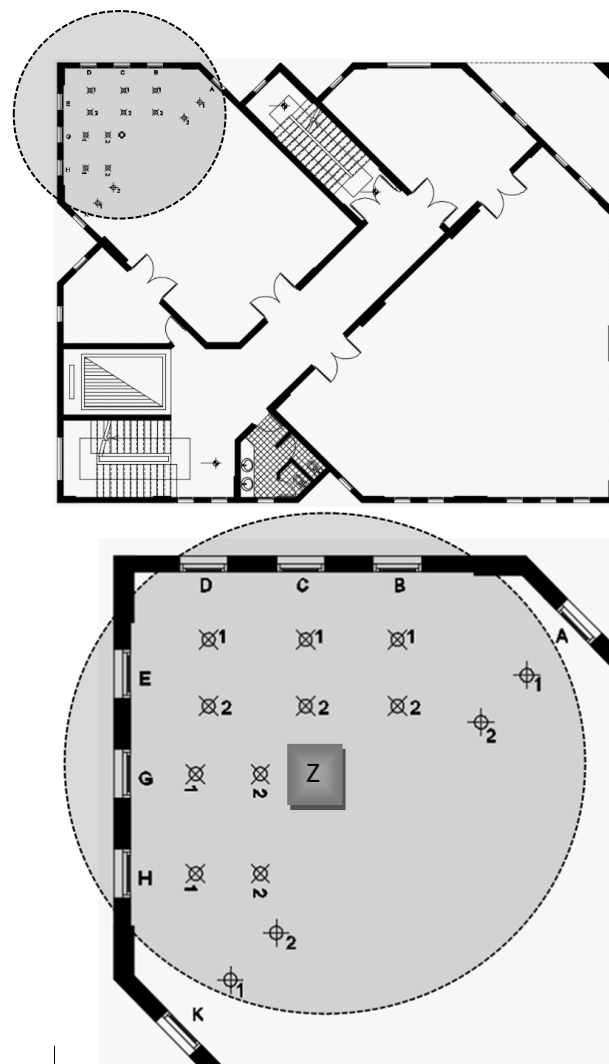

Fig. 28 plan of a multi-story building-case study- with lattice windows Tanta university, Egypt

A field measurement study in multi-story building with lattice windows were made by using Nova-Lynx weather station on 22/6/2019 11 am at a multistory building with lattice windows at Tanta university, Egypt to observe internal ventilation speed with synchronous external wind due to lattice windows ,and Fig 25 and 26 shows that large ornament screen creates a gradient pressure along the windward walls by redirecting normal wind to oblique because of it is geometry shapes, also large area of lattice window allows to reduce the interference of the ornament screens with the air flow.

4. conclusion

A computational fluid dynamics software package program ANSYS Fluent version14.5 used to simulate A model room, the model geometry assumed to be a three-dimensional domain Generated by using AutoCAD drawing program version 2016 and added to ANSYS Fluent software

A field measurement study in multi-story building with lattice windows were made by using Nova-Lynx weather station to observe internal ventilation speed and distribution with synchronous external wind to observe internal ventilation behavior and the role of lattice window in improving internal ventilation in such hot humid places due to its distinguished geometry features.

large ornament screen creates a gradient pressure along the windward walls by redirecting normal wind to oblique because of it is geometry shapes, also large area of lattice window allows to reduce the interference of the ornament screens with the air flow, side windows of lattice window create a lateral air movements beside walls, and Prominent element in lattice window is placed downwind to create a high pressure in front of it and

the other upwind side creates a negative pressure that improve air movement from high pressure to low pressure which allows wind to reach deeper into room space.



Fig. 29 Lattice Window- House of Egyptian Architecture-Cairo-Egypt

References

- [1] Webb, C. G. 1959. "An Analysis of Some Observations of Thermal Comfort in an Equatorial Climate." *British J. Industrial Medicine*, V-16, pp. 297-310.
- [2] Nicol, J. F. 1974. "An Analysis of Some Observations of Thermal Comfort in Roorkee, India and Baghdad, Iraq." *Annals of Human Biology*, V—1, pp. 411-426.
- [3] Humphreys, M. A. 1975. "Field Studies of 'Thermal Comfort Compared and Applied.'" Building Research Establishment, Current Paper. CP 76/75, UK: Garston, Watford.
- [4] Giovani, B. *Basic Study of Ventilation Problems in Housing in Hot Countries*. 1962. Building, Man, Climate and Architecture. 2nd ed. 1976. London; Applied Science Publishers;
- [5] Givoni, B. 1983a. "Review of Passive Heating and Cooling Research." *PLEA '93*, Oxford: Pergamon Press, pp. 339-352.
- [6] Givoni, B. *Basic Study of Ventilation Problems in Housing in Hot Countries*. 1962. Building Research Station Report. Technion-Institute of 'Technology.
- [7] Anderson, D. A., Tannehill, J. c., and Pleather, R. H., 1980 "Computational Fluid Mechanics and Heat Transfer" *Hemisphere*.
- [8] Harlow, F. H., and Nakayama, P. I., 1967 "Turbulent Transport Equations" *Physics of Fluids*, 10, 323.
- [9] Jones, W. P., and Launder, B. E., 1972 "The Prediction of Laminarization With a Two-Equation Model of Turbulence" *Int. J. Heat Mass Transfer*, Vol. 15, 301-314
- [10] <https://novalynx.com/store/pc/110-WS-25-Modular-Weather-Stations-p1073.htm>