

# Proceedings of the First International Conference on Solar Energy Solutions for Electricity and Water Supply in Rural Areas

7<sup>th</sup>-10<sup>th</sup> of October 2015  
The American University in Cairo  
Egypt



**Editors:**

Martina Jaskolski, Philipp Otter, Hubert Aulich

**Special thanks to:**

Zander Pellegrino, Florian Benz, Alexander Goldmaier, Hassan Hussein, Noha Mahmoud, Nermin Dessouky, Chelsea Estevez, Adam Ezroua and Sherifa El Alfy

## Welcome Note

### Dear participants, exhibitors and speakers of the First International Conference on Solar Energy Solutions for Electricity and Water Supply in Rural Areas,

Our conference hosted by the American University of Cairo/RISE was attended by almost 100 participants from Egypt, Germany, Malawi, the UK, the USA, Spain, Morocco and the United Arab Emirates. More than 25 papers and presentations were given, and participants were able to get involved during a workshop session, a panel discussion and poster presentation session. The feed-back we received from speakers, exhibitors and participants has been overwhelmingly positive, both in terms of conference content and the format chosen for the conference.

As was convincingly shown in the keynote addresses by Dr. Tutwiler, Dr. Aulich and Dr. Laamrani, our conference not only addressed two key Sustainable Development Goals of the United Nations – energy and water – but also contributed to the strive to develop sustainable energy and water solutions for the Middle East, North Africa and beyond. Case studies and solutions presented from Africa, the US and Europe gave the attending scientists, researchers, students and company representatives the feeling that there are many positive, innovative approaches to sustainable energy and water supply in rural areas.

Following the conference, a two day field trip attended by 27 participants facilitated a visit to the biggest wind park in the world located at Zaafarana and a visit to St Anthony's Monastery on the Red Sea which gave attendees a chance to see a well-functioning 200 kWp PV-System. The trip also showed all participants the huge potential Egypt has for generating electricity by using solar PV and wind.

The organizers would like to thank all attendees for participating in the many lively and constructive discussions, for sharing their experiences with solar energy and drinking water provision in rural areas, and for providing an open forum for hospitality and friendship. Last but not least, the organizers want to thank members of the American University in Cairo and RISE for an excellent organization of all sessions and events as well as friendly support in helping with travel and hotels.

The Organizing Committee is currently planning the next conference and will inform everyone on this next event.

#### Conference Organizers:



#### Many thanks to our conference supporters:



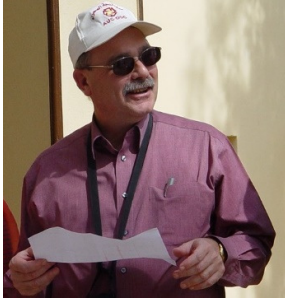

RISE strongly supports the goals of this conference. Small-scale, sustainable solutions to water and energy issues for impoverished rural communities, which are being identified and promoted by the conference, are essential for meeting the needs of the present and future generations of people in our region and the world.

**Dr. Richard Tutwiler**  
Director of the Research Institute  
for a Sustainable Environment

This conference has shown that combining autonomous solar energy systems with a sustainable management for save drinking water is the most promising way to improve the living conditions for hundreds of millions of people around the globe now.



**Dr. Hubert Aulich**  
Chairman of SolarInput and  
President of Sustainable Concepts



The Arab region political economy shows a common trend of unsustainable natural resources management in the three key development sectors of water, energy and agriculture. The reform of the water sector will be driven to a large extent by the policy choices in energy and food security priorities, making the water-energy-food nexus a forthcoming development agenda for the region towards sustainable development. A review of Intended Nationally Determined Contributions submitted to COP 21 by eleven countries from the Middle East and North Africa shows that solar energy solutions are assigned high priority for renewable energy development, in both oil- and non-oil producing countries. Solar energy for water access is gaining importance in regional renewable energy development. Events such as this conference can act as an impetus for more sustainable energy and water management in Egypt and the region.

**Dr. Hammou Laamrani**  
Advisor GIZ- Adaptation to Climate Change  
in the Water Sector  
Senior Advisor Arab Ministerial Water  
Council

# Conference

## Organizers

### **RESEARCH INSTITUTE FOR A SUSTAINABLE ENVIRONMENT (RISE)**

RISE is a research institute of the American University in Cairo that aims to advance sustainable resource management in Egypt and the MENA region through research, education and sustainable community development. The institute operates a range of research and teaching facilities on AUC's New Cairo campus, where its headquarters are located, including a rooftop garden, a climate control greenhouse operated by solar energy, a water laboratory, an organic garden, as well as hydroponics and aquaponics systems. RISE offers a range of educational programs for AUC students, as well as short training courses for external trainees and environmental education for children. Since 2006, RISE has been implementing a range of research and sustainable community projects across Egypt, including the oases of the Western Desert, the Delta, Upper Egypt and the southern Red Sea coast. These projects aim to improve water conservation and recycling, sustainable farming, and waste management, and include drinking water provision using sustainable technologies and renewable energy solutions. RISE also operates a research station in Sadat City.

### **AUTARCON**

AUTARCON GmbH is an SME based in Germany. The company focuses on developing and implementing technologically, ecologically and socially sustainable solutions for water supply in remote areas. The mission is to provide safe drinking water for people living in regions of the world with insufficient infrastructure to ensure access to clean and healthy drinking water. The company's technology, the SuMeWalSYSTEM, is an intelligent and comprehensive water purification solution that has won several sustainability and innovation prizes in Germany. The AUTARCON system can run on solar energy, requires no addition of chemicals, and no exchange of filters. Through AUTARCON technology, 25,000 people have gained access to safe drinking water in ten countries, among them Egypt, Tanzania, Ghana, Gambia, Haiti, Laos, India and Nepal. The SuMeWalSYSTEM makes safe water available to schools, hospitals and entire villages.

### **SOLARINPUT**

SolarInput is a non-profit organization founded in 2003 in Thuringia/Germany devoted to the advancement of photovoltaics and solar thermal energy. The organization manages a network of solar companies, R&D-institutes, universities, municipalities and state organizations to reduce the cost of solar electricity and to work on new applications mainly for the urban environment. In addition to this, SolarInput promotes and maintains international contacts mainly in Africa and South East Asia to disseminate its vast experience in the field of solar electricity and clean water for the application in rural areas world-wide.

## **SC SUSTAINABLE CONCEPTS**

SC Sustainable Concepts focuses its broad experience and know-how on material sciences, manufacturing and systems application in the field of photovoltaics for designing, financing and installing autonomous solar electricity systems that generate power for village electrification and the disinfection of water for safe drinking purposes. By combining the most advanced solar technology with the latest water disinfection technique, the company can bring electricity and safe drinking water to millions of people living in the rural areas, increasing their quality of life in a sustainable and economic manner. In addition, Sustainable Concepts works with national and international solar energy and water experts to disseminate know-how and technology in order to eliminate electricity and water poverty.

## TABLE OF CONTENTS

Solar Energy, Electricity and Water Supply in Rural Areas: A Globally Relevant Nexus.....	6
Chemical Impurities Detection in water environment using micro-optical sensors .....	10
Water Disinfection for Remote Areas – An Innovative and Sustainable Approach using Solar Technology and Anodic Oxidation.....	16
Challenges of Integrating Solar Energy Systems in Remote Areas of Egypt.....	22
The Feasibility of Solar Water-Pumping in a Rural Village of Malawi.....	30
Techno-Economic Feasibility of PV Irrigation in Egypt.....	38
The Concept of a Combined Water and Electric Microgrid for Rural Communities.....	53
General Characteristics of Mechanical Wind Water pumping System and the Possibility of Applying System in Egypt .....	59
Solar Energy Sustains Universal Self-Reliance in Water Supply .....	70
A Solar Water Pumping Solution Based on Industrial Variable Speed Drive (VSD) Technology .....	77
The Social Side of Water – Sustainability and Community Management of Solar Water Stations in the Oases of Egypt’s Western Desert .....	83
Small Scale Solar Energy Projects for Local Income Generation in the Oases of Egypt’s Western Desert – A Field Report .....	97
The Conference – Some Impressions .....	106
The Conference Excursion – Some Impressions.....	107

# **Solar Energy, Electricity and Water Supply in Rural Areas: A Globally Relevant Nexus**

Martina Jaskolski, Hubert Aulich, Philipp Otter, Adam Ezroua, Nermin Dessouky

## **Energy and Water - A Global Challenge**

This conference addressed a topic of global importance – the quest to meet our rising energy and water demands in rural areas through sustainable solutions that include innovative thinking, community management and new technologies. There are two particular United Nations Sustainable Development Goals to which this conference and these published conference proceedings aim to make a small contribution:

**First**, to ensure availability and sustainable management of water and sanitation for all, and **Second**, to enable access to affordable, reliable, sustainable energy for all.

Although these important goals on energy and water were already on the list of the millennium goals defined in the year 2000, insufficient progress has been made since then, particularly for the 50% of the world's population that lives in rural areas. One billion people in the world have no access to safe drinking water and approximately the same number has no access to electricity. A look at the global map reveals a large similarity in the distribution of people needing both safe drinking water and electricity. This poverty of water *and* electricity disproportionately impacts rural residents, and is particularly pronounced for those living in sub-Saharan Africa, India, Indonesia and parts of South America (Aulich, 2015, Conference Keynote Address).

During the past 15 years the advancements in solar electricity (photovoltaics) and modern techniques for supplying safe drinking water have led to dramatic reductions for the cost/kWh and the cost/l drinking water. By 2015, world-wide photovoltaic (PV) installations grew to approximately 235 Gigawatt peak (GWp), and for the coming years growth is expected to exceed 20% per annum. Impressive as these numbers are, growth of new and sustainable renewable energies (PV, wind, biogas) mainly happened in Europe, Japan and the USA. China also experienced impressive growth both in production and in installation of systems for all renewable energies (Aulich, 2015, Conference Keynote Address).

The water supply situation resembles the electricity supply, with large and well-functioning centralized systems in the developed world and insufficient capacities to supply water with acceptable quality for drinking and hygiene in other areas. Again, as is the case for electricity the situation in the rural areas is in general worse than in the urban centers. Around 80% of the nearly 800 million people without safe access to water live in rural areas. The number without access to water that meets the given quality criteria on pathogens and contaminants is substantially higher. The biggest water related threats to health are water-borne pathogens, such as vibrio cholera, spores, viruses or helminth eggs. Today, even after achieving the Millennium Development Goals (MDGs), 1.5 million children die every year due to lacking access to safe drinking water and sanitary facilities (UNICEF, 2012). These numbers show that despite technical progress, challenges in rural areas remain. Technical solutions that work in urban

context cannot simply be adapted to work in rural areas and low tech solution can only be intermediary solutions.

### **Space for Sustainable Solutions**

Advances in small scale PV-diesel hybrid systems are spreading electricity to previously unreached areas, at the same time water filtration and distribution solutions are emerging at the community level. This provides unique opportunities to pair electricity and clean water delivery in economically, environmentally and socially sustainable ways. While we see continuing cost reductions in the future on the technology side, considerably more progress needs to be made on financing the new systems and offering affordable systems communities. Business models have to be developed to offer government, local communities, NGO's, private investors and community residents an opportunity to participate in this emerging market.

The organizers of this conference are convinced that bringing together experts and users of the two sectors will not only lead to further technological advancements but also to an increase in shared understandings regarding technical and regulatory systems that make these solutions possible. We think that this conference will be just the first in a series of conferences to come that take advantage of this combined effort and hope it can contribute to the accomplishment of the Sustainable Development Goals.

### **Why Egypt?**

The First International Conference on Solar Energy solutions for Electricity and Water in Rural Areas was held in Cairo. The Middle East is an area that suffers from water scarcity, in some places absolute water scarcity (defined as less than 500 m<sup>3</sup> of water per person). While non-renewable energy resources such as oil and gas are still plentiful in some countries of the Middle East, growing population numbers and rising energy and water demand pose challenges for the distribution of services, especially to rural areas.

In Egypt, the nexus of water and energy in the context of sustainable urban and rural development is a particularly relevant topic, as the country is dealing with a rapidly growing population, 98% of which densely populates the Nile Valley and Delta, and 4% of which resides in areas of which some are extremely remote, located in the heart of the desert, hundreds of kilometers away from urban centers and the Nile.

In Egypt, population numbers are growing by around a million every ten months and are expected to rise from 90 million in 2015 to up to 150 million in 2050 (MWRI, 2014). Given the continuous strain on energy resources around the world, the Egyptian energy sector is struggling to cover its energy needs. According to the Ministry of Electricity and Energy's annual report released in 2014, Egypt produced 168 billion KWh that year, 91% of which were generated from non-renewable sources, contributing 35% to the country's carbon emissions (Patlitzianas, 2011). In 2010, Egypt's energy supply was composed of 52% oil, 46% gas, and 2% coal (Razavi, 2012). The energy demand in Egypt had witnessed a 4.5% annual growth rate during the past two decades (Razavi, 2012). Although the rate of electricity generation is



expected to double between 2003 and 2030 in an attempt to meet this rising demand, Egypt will need some 19 Gigawatt of additional capacity by 2030 (Patlitzianas, 2011).

Diesel and gasoline are heavily subsidized in Egypt in order to make these resources more widely available to the country's citizens – a topic of political debate – Egypt's rural population has gone through a number of crises related to the availability of diesel and gasoline. Shortages have led to hours and days of queuing in front of remote petrol stations negatively impacting local businesses, farming activities, which rely heavily on diesel operated pumps, and local livelihoods. While, according to the World Bank, 99% of Egypt's rural population have access to improved drinking water, treated drinking water in rural areas is in reality often not fit for direct consumption and has to be re-filtered at the household level. With Egypt having been classified as a country suffering from water poverty, and per capita shares of fresh water already well below the poverty mark of 1,000 cubic meters per person per year, it is not only the quality, but also the quantity of water that will become an issue in Egypt (MWRI, 2014). Egypt's main fresh water resource, the Nile River, originates outside the country's borders. Providing 97% of the country's fresh water, the Nile and the share available to Egypt have been points of political debate with Sudan and Ethiopia. Meanwhile, Egypt's largest aquifer, the Nubian Sandstone Aquifer, is non-renewable and is already suffering considerable water stress.

While problems abound, there is also room for improvement. Increasing of the share of renewable energy sources for electricity production in Egypt is high on the political agenda. The energy sector is trying hard to explore and invest in renewable energy sources in order to produce an affordable and sustainable energy source that cause lesser carbon emissions. At the same time, discussions about expanding nuclear energy facilities and coal mining in Egypt have become louder in recent years as well. It was thus timely to hold a conference in Egypt that may contribute to shaping the way towards more innovative sustainable solutions at a time when groundbreaking decisions for Egypt's future energy supply are being made.

With Egypt's prime location under the so-called 'sun belt', solar energy is one of the country's greatest potentials when it comes to renewable energy. Egypt is internationally recognized as one of the major sites that can generate solar energy, not only to serve local needs but also to export electricity to Europe. In the past, the investment cost of solar energy was fairly high, especially compared to the subsidized Egyptian fossil fuels. This sometimes led to a disregard of solar energy as a potential competitor in the market and limited the role of solar energy to generating energy in mostly off-grid situations. With continuous development in technology over time, solar energy technology became cheaper all over the world, opening the window for on-grid development projects as well (Sarant, 2015). Also, with the recent implementation of a feed-in-tariff scheme by the Egyptian government in the face of increasing power shortages, more development in the solar energy sector is expected in the coming years (PriceWaterCoopers, 2015).

One of the most important solar energy projects implemented in Egypt is the 120MW Integrated Solar Combined-Cycle Kuraymat plant, which combines the advantages of both solar energy (20 MW) and a gas turbine cycle (120 MW) (Concentrating Solar Power Projects,

2013). On the small and medium scale, Egypt has seen many SMEs and entrepreneurs 'ride the solar wave' and invest in smaller-scale solutions for solar electrical generation and other applications.

## REFERENCES

**KarmSolar, 2011:** *Pumping and Irrigation*. Accessed from <http://karmsolar.com/pumping-irrigation/> (24 February 2016).

**The Middle East Institute, 2015:** *The Rise of Solar Energy in Egypt*. Accessed from <http://www.mei.edu/content/article/rise-solar-energy-egypt> (24 February 2016)

**National Renewable Energy Laboratory, 2013:** *Concentrating Solar Power Projects*. Accessed from [http://www.nrel.gov/csp/solarpaces/project\\_detail.cfm/projectID=65](http://www.nrel.gov/csp/solarpaces/project_detail.cfm/projectID=65) (24 February 2016).

**Patlitzianas, K. D., 2011:** Solar Energy in Egypt: Significant Business Opportunities. *Renewable Energy*, 36(9), 2305-2311.

**PriceWaterCoopers, 2015:** *Developing Renewable Energy Projects, A Guide to Achieving Success in The Middle East*.

**Razavi, H., 2012:** *Clean Energy Development in Egypt*. The African Development Bank.

# Chemical Impurities Detection in water environment using micro-optical sensors

Amir R. Ali<sup>1,2\*</sup>

<sup>1</sup> Applied-Science & Robotics Laboratory for Applied Mechatronics (ARAtronics Lab.); Mechatronics Engineering Department, German University in Cairo, Cairo, 11835, Egypt

<sup>2</sup> Micro-Sensor Laboratory, Mechanical Engineering Department, Southern Methodist University, Dallas, Texas, 75275, USA

\*Corresponding author: amir.ali@guc.edu.eg; arahmed@smu.edu; phone 012-2-22-57-086

## ABSTRACT

In this paper, we discuss dielectric micro-optical sensors that monitor chemical impurities in contaminated drinking water environments based on the whispering gallery mode phenomenon (WGM). Some chemical impurities could be toxic and carcinogenic to humans and animals. The biogeochemical reactions are responsible for the movement of these impurities in the drinking water environment. Based on that, it is important to measure and quantify the concentration of these impurities in the water medium. In our experiment, which this present paper discusses, a high-resolution micro-optical sensor concept is used to detect these chemical impurities. The sensing element is a silica microsphere that acts as an optical resonator. The measurement principle is based on the WGM shifts of the microsphere. The proposed sensor aims to provide preliminary results demonstrating the practical use of these sensors for effective monitoring of chemical impurities concentrations and contaminants, such as sodium phosphate, a salt that can cause serious kidney damage and possibly death. Results indicate that the WGM based-sensors are sensitive enough to detect refractive index changes in the case of liquid media (water). Experiments were carried out to validate the analysis and to provide an assessment of this sensor concept.

## 1. INTRODUCTION

Recently, optical microsphere resonators have sparked interest due to their high quality factors. The quality factor,  $Q$ , is a measure of the resolution of the optical resonance, also known as the whispering gallery mode (WGM), of the sphere.  $Q$  is defined as,  $Q=\lambda/\delta\lambda$ , where  $\lambda$  is the wavelength of the laser and  $\delta\lambda$  is the resonance line width. There are reported  $Q$  values approaching a material loss limit of  $10^{10}$  (Jonáš et al., 2012). These extremely high  $Q$  values provide the opportunity for detection of very small morphology-dependent shifts in micro spherical sensor's whispering gallery modes. A current method of measuring the extremely high  $Q$  factors is by coupling a laser into a micro-spherical resonator using tapered optical fibers (Offrein et al., 1999). These morphological changes can result from changing stimuli in the environment and provide for a range of new sensor development opportunities. By monitoring the effects of the stimuli on the microsphere WGM, it is possible to determine the corresponding physical state of the surrounding environment. These unique characteristics of micro-spherical resonators have been used in multiple biological and mechanical sensing applications, including but not limited to: laser frequency locking and stabilization, micro cavity laser technology, optical communications (switching, filtering and multiplexing (Ilchenko et al., 1998; Little et al., 1997; Tapalian et al., 2002) and sensor technologies in

mechanical and biological applications (Ali et al., 2012, 2013, 2014; Ali and Ioppolo, 2014; Guan et al., 2006; Ioppolo et al., 2008; Toland et al., 2012; Vollmer et al., 2002).

The simplest interpretation of the WGM phenomenon comes from geometric optics. When laser light is coupled into the sphere nearly tangentially (Figure 1a), it circumnavigates along the interior surface of the sphere through total internal reflection.

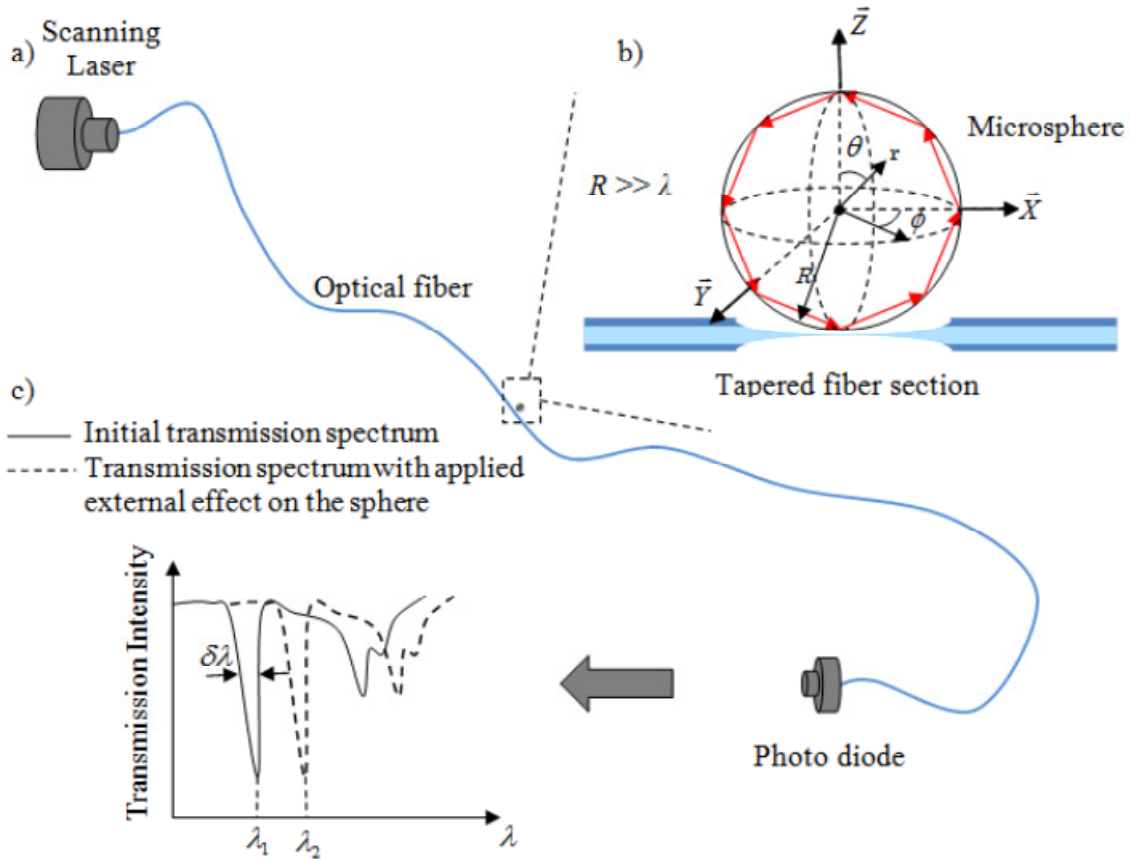

**Figure 1:** a) Typical WGM sensor configuration, b) Ray optics model of light traveling inside sphere for one round trip, c) Transmission spectrum for a spherical resonator (Ali).

An optical resonance is realized when light returns to its starting location in phase. A common method to excite WGMs of spheres is by coupling tunable laser light into the sphere via an optical fiber. The approximate condition for resonance is

$$2\pi n_1 R = l\lambda \quad (\text{Equation 1})$$

Where  $a$  and  $n_1$  are the sphere radius and refractive index respectively,  $\lambda$  is the vacuum wavelength of the light, and  $l$  is an integer indicating the circumferential mode number. Equation 1 is a first order approximation and holds for  $R \gg \lambda$  (Figure 1b). At resonance, light experiences constructive interference in the sphere, which can be seen as dips in the transmission spectrum through the optical fiber (see Figure 1c). A fractional change in the index of refraction or the radius will induce a shift in the WGM as

$$\frac{d\lambda}{\lambda} = \frac{dn_1}{n_1} + \frac{dR}{R} \quad (\text{Equation 2})$$

Several characteristics make polydimethylsiloxane (PDMS) useful in fabricating micro-sensing devices intended for bioanalysis: ease of fabrication (rapid prototyping, sealing, interfacing with the user), transparency in the UV-visible regions, chemical inertness, low polarity, low electrical conductivity, and elasticity. PDMS does not swell when in contact with water. The cost of fabrication in PDMS is low compared to that of many materials (e.g., glass or silicon) commonly used in micro-devices and MEMS.

## 2. EXPERIMENTAL SETUP

A schematic of the opto-electronic system is shown in Figure 2.

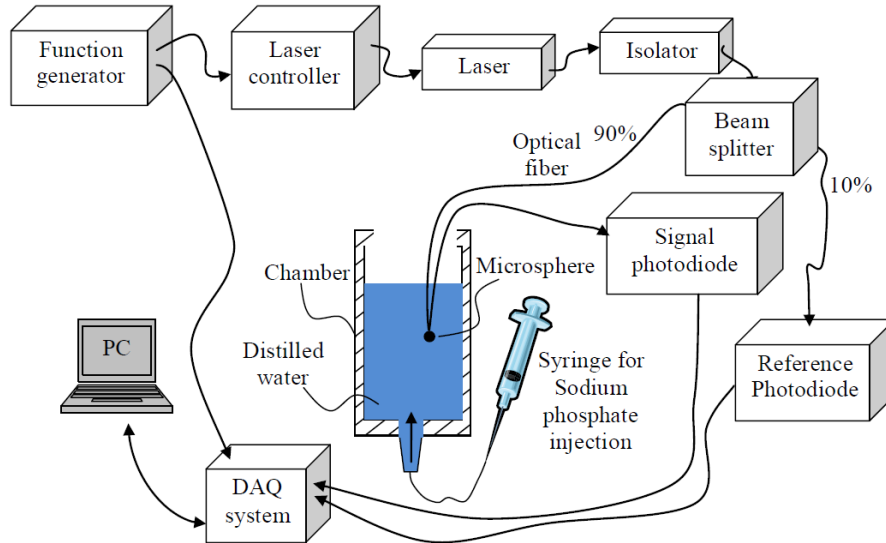

**Figure 2:** Schematic of the opto-electronic system used in the experimental setup (Ali).

The output of a distributed feedback laser diode (DFB) with a nominal wavelength of ~1312 nm and power of 5mW is coupled into a single-mode optical fiber. Approximately 90% of the light intensity is used to interrogate the WGM of the sensor, while the other portion of the laser light (about 10% of the total intensity) is extracted through a splitter to use as a reference signal.

Both the reference and the 90% intensity signal fibers are terminated at photo diodes (PDs). The DFB laser is current-tuned using a laser controller that also keeps the laser diode's temperature constant. The controller is driven by a function generator, which provides a saw-tooth voltage output. The two PD outputs as well as the function generator output are sampled using a 16-bit data-acquisition card (DAQ) and processed by a host personal computer (PC). The reference PD output is used to normalize the transmission spectrum from the sensor fiber. The host personal computer (PC) performs the scanning, data acquisition and analysis. A software module, developed in-house, identifies the WGM in the transmission spectrum and monitors their shifts. It provides a reliable and fast fit to an experimental WGM spectrum and enables a continuous tracking and recording of resonance shifts in real time.

### 3. ANALYSIS AND DISCUSSION

In these experiments, the effect of sodium phosphate concentration (in water) on the WGM shifts is studied. The sensing element, the microsphere, is placed in deionized water in a container. A sodium phosphate solution was gradually added to the container and allowed to diffuse for uniform concentration before the WGM shifts are observed. The temperature was kept at a constant value of 22°C and monitored by a thermocouple. The transmission spectrum was digitized and stored on the host PC to determine the WGM shift ( $\Delta \lambda$ ). The measurements were repeated using silica microspheres with five different radii ranged from 100µm to 500µm. The WGM shifts are sensitive to the refractive index changes in the case of liquid media (water) as it is reported in Ioppolo et al. (2010),

$$\Delta n_2 \propto \Delta \lambda$$

$$\Delta n_2 = \frac{2\pi R (n_1^2 - n_2^2)^{3/2}}{\lambda^2 n_2} \Delta \lambda$$

(Equation 3)

where  $n_2$  and  $\Delta n_2$  are the refractive index of the medium and the change in the medium index of refraction respectively. Figure 3 (left) shows the experimental measurements for the shifts in WGM when the sodium phosphate solution was gradually added to the deionized water. The change in the index of refractive index  $\Delta n_2$  can be determined based on Equation 3. Figure 3 (right) is a parametric and experimental study for the effect of the sphere size on the WGM shifts. The results show that the small sphere has high-resolution to detect the sodium phosphate in the deionized water.

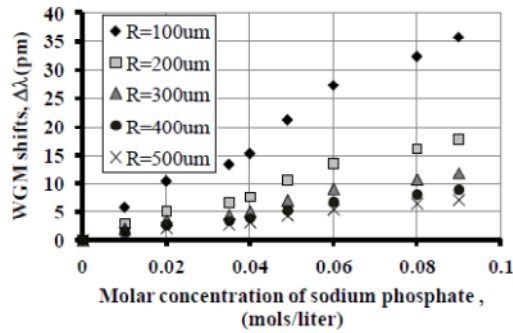

**Figure 3.** Measured WGM shift dependence on the sodium phosphate concentrations

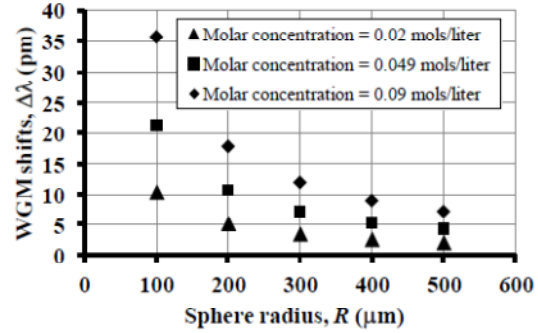

**Figure 4.** Measured WGM shift dependence on the sphere size

**Figure 3:** Measured WGM shift dependence on the sodium phosphate concentrations (left) and Measured WGM shift dependence on the sphere size (right) (Ali).

#### 4. CONCLUSION

This paper discussed an optical chemical impurities sensor based on the whispering gallery modes of spherical resonators. In the present design with silica spheres, the preliminary results demonstrated the practical use of these sensors for effective monitoring of chemical impurities concentrations and contaminants, such as sodium phosphate. As the sodium phosphate solution was gradually added to the water, the WGM shifts were observed. Experimentally, the WGM based-sensors proved to be sensitive enough to refractive index changes in the case of liquid media (water).

#### REFERENCES

**Ali, A. R., Ioppolo, T. and V. Ötügen, 2012:** *High-Resolution Electric Field Sensor Based on Whispering Gallery Modes of a Beam-Coupled Dielectric Resonator*. Proceedings of the International Conference on Engineering and Technology (ICET), October 2012, 1,6, 10-11.

**Ali, A. R., Ioppolo, T. and Ötügen, V., 2013:** *Beam-Coupled Microsphere Resonators for High-Resolution Electric Field Sensing*. Proc. SPIE 8600, Laser Resonators, Microresonators, and Beam Control XV, 86001R; doi:10.1117/12.2007387.

**Ali, A. R., Ioppolo, T., Ötügen, V., Christensen, M. and MacFarlane, D., 2014:** Photonic Electric Field Sensor Based on Polymeric Microspheres, *Journal of Polymer Science Part B: Polymer Physics*, 52(3), 276–279.

**Ali, A.R. and Ioppolo, T., 2014:** Effect of Angular Velocity on Sensors Based on Morphology Dependent Resonances, *Sensors*, 14, 7041-7048.

**Guan, G., Arnold, S. and Ötügen, M.V., 2006:** Temperature Measurements Using a Micro-Optical Sensor Based on Whispering Gallery Modes, *AIAA Journal*, 44, 2385-2389.

**Ilchenko, V.S., Volikov, P.S., Velichansky, V.L., Treussart, F., Lefevre-Seguin, V., Raimond, J. M. and Haroche, S., 1998:** Strain Tunable High-Q Optical Microsphere Resonator, *Optics Communications*, 145, 86–90.

**Ioppolo, T., Kozhevnikov, M., Stepaniuk, V., Ötügen, M.V. and Sheverev, V., 2008:** Micro-Optical Force Sensor Concept Based on Whispering Gallery Mode Resonances, *Applied Optics*, 47(16), 3009-3014.

**Ioppolo, T., Das, N. and Ötügen, V., 2010:** Whispering Gallery Modes of Microspheres in the Presence of a Changing Surrounding Medium: A New Ray-Tracing Analysis and Sensor Experiment, *Journal of Applied Physics*, 107, 103-105.

**Jonáš, A., Karadog, Y., Mestre, M. and Kiraz, A., 2012:** Probing of Ultrahigh Optical Q-Factors of Individual Liquid Microdroplets on Superhydrophobic Surfaces Using Tapered Optical Fiber Waveguides, *Journal of the Optical Society of America B*, 29(12), 3240-3247.

**Little, B.E., Chu, S.T. and Haus, H.A., 1997:** Microring Resonator Channel Dropping Filters, *Journal of Lightwave Technology*, 15, 998-1000.

**Offrein, B. J., Germann, R., Horst, F., Salemink, H. W. M., Beyerl, R. and Bona, G. L., 1999:** Resonant Coupler-Based Tunable Add-After-Drop Filter in Silicon-Oxynitride Technology for WDM Networks, *IEEE Journal of Selected Topics in Quantum Electronics*, 5, 1400-1406.

**Tapalian, H.C., Laine, J.P. and Lane, P.A., 2002:** Thermo Optical Switches Using Coated Microsphere Resonators, *IEEE Photonics Technology Letters*, 14(8), 1118-1120.

**Toland, J., Arouh, S., Diggins, C., Sorrentino, C. and Search, C., 2012:** Enhanced Gyroscope Scale Factor in an Area-Chirped Array of Coupled Matter-Wave Interferometers, *Physical Review A*, 85, 043614.

**Vollmer, F., Brown, D., Libchaber, A., Khoshima, M., Teraoka, I. and Arnold, S., 2002:** Protein Detection by Optical Shift of a Resonant Microcavity, *Applied Physics Letters*, 80, 4057-4059.



# **Water Disinfection for Remote Areas – An Innovative and Sustainable Approach using Solar Technology and Anodic Oxidation**

Philipp Otter\*, Martina Jaskolski\*\*, Alexander Goldmaier\*

\* AUTARCON GmbH, Franz-Ulrich-Str. 18F, 34119 Kassel Germany, +49 561 5061 868 92

\*\* The American University in Cairo, Research Institute for a Sustainable Environment , 74 90<sup>th</sup> Street, New Cairo, Egypt 11835, +2 2615 4435

## **KEYWORDS**

Decentralized Water Supply, Electrolysis, Solar Energy Supply, Anodic Oxidation, Drinking Water Disinfection, Residual Chlorine, Iron removal

## **ABSTRACT**

This paper introduces the technical challenges of off-grid water supply in developing regions. Disinfection is of prime concern in off-grid water treatment. To solve this challenge, an alternative approach of applying solar generated electricity and inline electrolytic chlorine production (Anodic Oxidation) was tested. This technology has been integrated into an intelligent and comprehensive drinking water supply system (SuMeWa – Sun Meets Water) for remote off-grid regions. The system has been adapted for long-term iron removal and was employed for the first time in 2014 in the Oasis of El Heiz in the Western Desert of Egypt. Experience from that pilot project will be explored.

## **1. INTRODUCTION**

Still today, nearly 800 million people do not have access to water. The number of people without access to safe water is substantially higher. Over 80% of the people without access to drinking water live in remote rural areas. The biggest water-related threats to health are water-borne pathogens, such as vibrio cholera, spores, viruses or helminth eggs. Still today, even after achieving the MDG, 1.5 million children die every year due to a lack of access to safe drinking water and sanitary facilities (UNICEF, 2012). The disinfection of water has therefore highest priority in the supply of water for currently underserved regions (WHO, 2008). Currently, several low-tech approaches, such as clay pot filtration, SoDis disinfection, chlorine dosing or boiling are being proposed for water treatment in rural areas. These methods are easy to apply and relatively safe, however require a stringent application by the user. Technical solution such as ultrafiltration or ultraviolet radiation are being employed as well, however require frequent maintenance and exchange of spare parts. Further, except for chlorine dosing, no method supplies any residual disinfectant that can keep the water safe after the initial treatment. Because of its efficiency in killing off germs and its residual capacity, chlorine is still the worldwide mostly applied and legally required disinfectant (WHO, 2008). The disinfection of the water by the so called Anodic Oxidation, where the necessary quantity of chlorine is produced on site from the natural salt content of the water, is hereby a promising alternative to presently propagated solutions.

## 2. ANODIC OXIDATION

Sufficiently stable and efficient electrode materials for electrochemical water disinfection have become available in the last 20 years. Electrodes with mixed oxide coatings based on iridium and/or ruthenium oxide have proven to be the most stable combinations for chlorine production. Overvoltage for competing reactions is sufficiently high to favor the production of chlorine even from the low chloride concentrations found in freshwater water sources (Kraft, 2008).

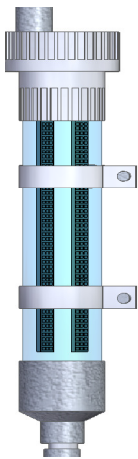
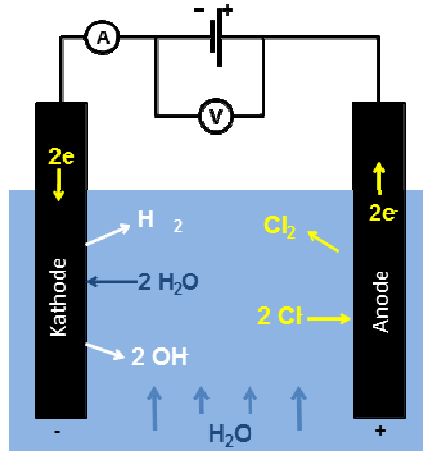

Chlorine production in electrolytic cell:

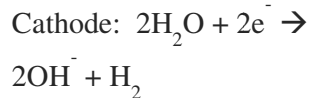

Reaction of chlorine in water:

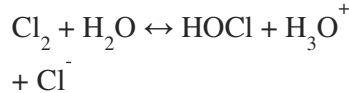

**Figure 1:** Electrolytic cell and production of chlorine gas as disinfecting agent.

Even with source water that has chloride concentrations as low as 10 mg/L sufficient oxidizing agent to assure complete pathogenic removal can be produced with these electrolytic cells. This allows the application of this technology for nearly all source waters, except rain water (Otter et al., 2014).

## 3. FULL-SCALE TREATMENT UNIT – SuMeWalSYSTEM

Within past research activities the anodic oxidation process for inline chlorine production has been integrated into a fully autonomous water treatment system (Otter, 2011). This system is capable of pumping, filtering disinfecting water in remote regions. Water quality is monitored and if required, adapted by a patented sensor setting. Chemicals are not required. Thus the unit

is especially well suited for the implementation in off-grid regions. The basic working principle is shown in Figure 2.

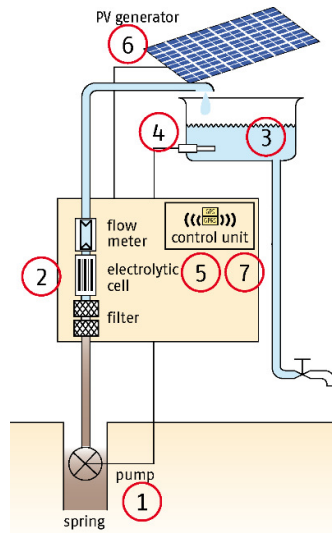
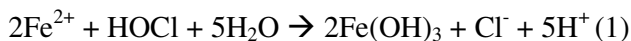

**Figure 2:** Working principle of SuMeWaSYSTEM.

1. Freshwater is lifted with a submersible pump from depths of up to 70 m.
2. After the filtration process, chlorine is produced in the electrolytic cell from salts that occur naturally in most fresh water sources.
3. In the reservoir, the disinfected water is safely stored. From here it can be tapped or distributed via a central piping network.
4. The water quality is continuously monitored.
5. Depending on the water quality the control unit adapts the disinfection process.
6. Due to the included solar photovoltaic modules, SuMeWa works self-sufficiently and is independent of any infrastructure. Batteries are not required.
7. All operational parameters are sent online for remote control.

a) Iron and manganese in source water

Many water sources contain elevated levels of iron and manganese. Both reduce the palatability of the water, stain clothes and clog water pipes. In order to cope with this water, a modularized iron filter was developed that can be integrated into the treatment station whenever required. Besides the production of a disinfectant, this unit pre-oxidizes iron through inline electrolytic chlorine and oxidant production.



The ferric hydroxides precipitate and form iron sludge. This sludge is retained in the media filter. In order to remove filtered iron sludge, the filter is backwashed automatically on a frequent basis, so that the filter does not need to be exchanged.



**Figure 3:** Iron sludge removed from filter and clear drinking water in Egypt.

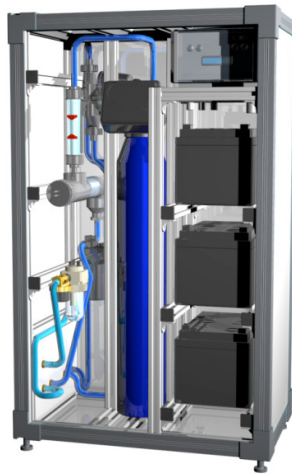

**Figure 4:** SuMeWalIRON - fully integrated water treatment and supply system for iron removal running on solar energy only.



**Figure 5:** SuMeWalIRON - fully integrated water treatment and supply system for Iron removal running on solar energy only.

#### 4. EL HEIZ PROJECT

The oases of Egypt's Western Desert rely solely on the water of the Nubian Sandstone Aquifer, extracted from depths of between 350 and 1,200 meters. The groundwater extracted in the Western Desert has extremely high natural iron levels of up to 15 mg/L. As a reference, WHO guidelines suggest a maximum iron content of 0.3 mg/l, whereas 0.02 mg/L are advisable to increase palatability and reduce staining. Once water is pumped to the surface sludge forms and bacteria grow. Local residents manually filter the water before they can drink it. Problematically, the clay filters (*zirs*) do not remove all pathogens in the water, which accumulate and multiply particularly as water is stored for several days in plastic jerry cans around the house before being consumed.

Given that the oases of Egypt's Western Desert are in extremely remote locations, any system that requires extensive exchange of spare parts is ultimately unsustainable. The community of El Heiz, located about 150 km north of Farafra, used to have several drinking water stations installed by the government that have either never worked or stopped working after a period of only a few months. The supply of bottled drinking water is limited only to the very rich inhabitants of the Western Desert. In early 2014 the Research Institute for a Sustainable Environment (RISE) at the American University of Cairo team decided to implement the AUTARCON technology in El Heiz Oasis.

#### 5. RESULTS AND CONCLUSIONS

When installed, the iron removal unit produces up to 4,000 L daily, which is supplied to the entire village, and draws desert residents from a radius of up to 50 km. The system is fully running on solar PV, as there is no constant electricity supply in the village. Given that the village well pump only operates for around an hour per day, an intermediary 5 m<sup>3</sup> storage tank was installed from where the unit takes its water to be treated. The system's chlorination ensures that neither bacteria nor other pathogens can grow in the water or in the jerry cans used for transporting the water. Iron levels have been successfully reduced below 0.02 mg/l (Table 1).

**Table 1:** Basic water quality parameters before and after treatment in El Heiz

Parameter	WHO guideline value	Source Water	Treated Water
pH	6,5 – 8,5	6,76	7,02
Temperature	--	25,8°C	24,0°C
Conductivity	--	341 µS/cm	338 µS/cm
Iron	0,3 mg/L *	5,64 mg/L	<0,02 mg/L
Chloride	250mg/L	54,5 mg/L	52 mg/L
Chlorine	> 0,5 mg/L	0	1,0 mg/L

\*< 0,02 mg/L are suggested to prevent staining

The treated water is completely clear, safe and has a pleasant taste and the station is working very reliably. Besides the improved access to clear and tasteful water, the health situation of the oasis habitants as well as the hygienic conditions of water storage and consumption have significantly improved.



**Figures 6 and 7:** Water before and after treatment and children tapping the water in El Heiz.

Because of these projects, inhabitants of other oases in the Western Desert have become interested in implementing these water stations and asked for support on how this can be made feasible. By the date of this publication four more units have been installed and six more sites for system implementation have been identified.

## REFERENCES

**Kraft, A., 2008:** Electrochemical Water Disinfection – A Short Review, *Platinum Metals Rev.*, 2008, 52(3), 177-185.

**Lenntech, 2014:** *Umkehrosmoseanlagen, Generelle Auslegung der RO Anlagen.* Accessed from: <http://www.lenntech.de/prozesse/entsalzung/ro/umkehrosmose.htm>, (20 August 2014).

**Otter, P., Goldmaier, A., 2014:** *Solar Driven Drinking Water Supply Using Anodic Oxidation as Energetically Efficient Disinfection Alternative.* Otti International Conference on Solar Energy Technology in Development Cooperation, Frankfurt am Main, November 2014.

**Otter, P., Goldmaier, A., 2014:** Solar- und Wassertechnik ermöglichen neue Lösungsansätze für die Trinkwasserproblematik in Entwicklungsländern, *Deutsche Lebensmittel Rundschau*, Februar 2014.

**Otter, P., Benz, F., 2011:** Sun Meets Water – Neue Wege in der dezentralen Wasseraufbereitung. *DGS Sonnenenergie*, 4, 2011.

**UNICEF and World Health Organization, 2012:** *Progress on Drinking Water and Sanitation 2012 Update.* Accessed from <http://www.unicef.org/media/files/JMPreport2012.pdf> (20 August 2014).

**WHO, 2008:** *Guidelines for Drinking-Water Quality.* Third Edition Incorporating the First and Second Amddenda Volume 1 Recommendations, WHO Press, Geneva.

# Challenges of Integrating Solar Energy Systems in Remote Areas of Egypt

Lessons learnt from the case of Qarat Um Elsaghir Village

By: Eng. Aya El-Wagieh (a) Dr. Marwa Abdellatif (b) and Prof. Dr. Mohamed Salheen (c)

a Teaching Assistant in Urban Planning and Design, IUSD Program, Ain Shams University. Email: Aya.elwagieh@eng.asu.edu.eg

b Assistant Professor of Urban Planning and Design, IUSD Program, Ain Shams University. Email: m.abdellatif@eng.asu.edu.eg

c Professor of Integrated Planning and Design, IUSD Program, Ain Shams University.

Email: mohamed\_salheen@eng.asu.edu.eg

Address: 1 El-Sarayat Street, 11517 Abbasiya, Cairo, Egypt

## ABSTRACT

The energy sector in Egypt faces challenges that threaten energy security. This is witnessed in the increase of energy consumption and the wide gap between demand and supply. The reason for this gap could be population growth combined with high subsidy policies for energy, which do not encourage a reduced demand. Furthermore, one of the main reasons is the excessive reliance on energy generated from fossil fuels, which is usually subjected to fluctuating costs. In response to this energy crisis, the Egyptian government plans to increase the renewable energy share to 20% of the overall energy supply by 2020 (NREA, 2013).

Accordingly, The New and Renewable Energy Authority (NREA) is working on providing electricity for 195 remote villages and residential communities using photovoltaic (P.V.) technology. Such plans are expected to cause significant alterations in landscape and affect the cultural and visual perception of these communities. Such alternations have been explored by authors in previous research in Qarat Um Elsaghir village; The NREA already provided electricity for villages in the Western Desert. Throughout the research related to the NREA's last project, one can read that the residents pinpointed various deficiencies in the introduced P.V. system including concerns related to: sense of ownership toward the introduced P.V. system, maintenance of the system, and P.V. performance and efficiency with respect to their needs.

This paper highlights the importance of considering the socio-cultural, financial, maintenance and managerial aspects when planning sustainable solar energy systems in remote areas by observing deficiencies in the previously introduced system in "Qarat Um Elsaghir." The paper additionally attempts to propose a preliminary model that incorporates the aforementioned aspects in order to sustain and integrate the P.V. solar technology within the remote communities, based on lessons learnt from Qarat Um Elsaghir project, local and international case studies.

## **1. BACKGROUND**

The frequent electricity cuts in Egypt in the past three years demonstrate the energy sector's challenges. On the one hand, industrial development, population growth, energy subsidy policies and lack of diverse energy resources were pinpointed as the main reasons for the gap between demand and supply (Economic Research Portal, 2013). On the other hand, the U.S. Energy Information Administration stated that the remoteness of various areas in Egypt left 300,000 residents with no electricity (2013). As a result, many remote villages are dependent on diesel generators, which provide limited electricity for a few hours a day. Focusing on this issue, the NREA paid special attention to provide energy in the remote areas through P.V. solar panels. Accordingly, a partnership between the Ministry of Electricity and United Arab of Emirates was established aiming at providing electricity in 195 remote villages by P.V. technology in Matrouh governorate and Upper Egypt (NREA, 2013). This large scale project requires appropriate planning to sustain the introduced technology in the remote area. For that matter, this paper attempts to develop a preliminary model for sustainable renewable energy systems in remote areas deduced from scanning the international and local sustainable experiences. Additionally, one of the two already implemented electricity generation projects carried out by the NREA in the remote village of Qarat Um Elsaghi in Siwa oasis, Egypt is reviewed.

## **2. REVIEWING CONCEPTUAL FRAMEWORK FOR PLANNING SUSTAINABLE ENERGY PROJECT**

In an attempt to advance a conceptual framework for the design of sustainable energy landscape, Stremke emphasized the importance of utilizing renewable energy in a sustainable manner (2013). He differentiated between renewable and sustainable energy whereby sustainable energy is renewable, but not all renewable energy is sustainable. By this rationale, he understands sustainable energy as a quality that characterizes how renewable energy source function in a dynamic physical state. Based on this, a conceptual framework for a sustainable energy landscape was developed pinpointing four main criteria: technical, environmental, economic and socio-cultural, shown in Figure 1, where the core of minimum technical criteria in any project occurs in the center. In this regard, he mentioned that this framework is conceptual, because the size, number and type of the criteria are dependent on the nature of the project.



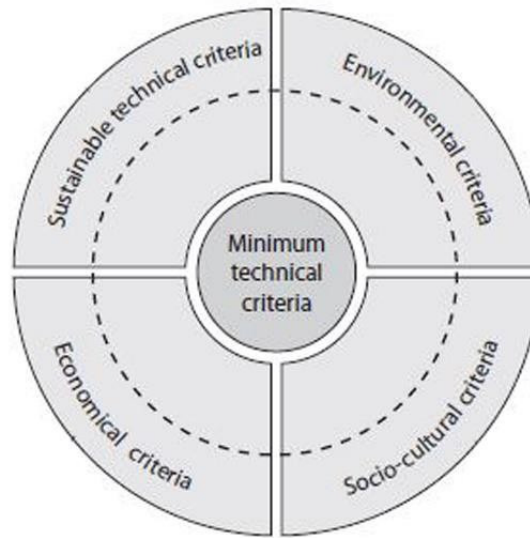

**Figure 1:** Schematic representation of relations between groups of criteria for sustainable energy landscape planning (Stremke, 2013).

Reviewing the international and local context of P.V. electricity generation projects, two case studies were found to be of significant relevance to community-based sustainable electricity generation projects. The first case study explored, “Powering West Africa,” funded by the UN Development Program (UNDP) (Assogba, 2014), discussed providing electricity for 14 villages across the West Africa region. This project succeeded in considering the aforementioned criteria by Stremke (2013). In terms of economic aspects, the inhabitants’ financial contributions were considered, even if at minimal percentages. Additionally, the residents are currently paying a monthly fee of 10 US dollars for maintenance and spare parts. In terms of technical aspects, a partnership between UNDP and the hosting governments provided technical trainings in colleges for community-selected inhabitants to be able to perform installations, maintenance and network expansion. During six months, they became solar engineers responsible for maintaining the solar-powered systems in their villages. They received a salary from the monthly fees paid by each family. Moreover, they trained other residents to be their assistants. Meanwhile, spare parts stores were provided, which secured an immediate accessibility to them.

The local case study explored is called Tanweer El Heiz Village in Bahariya Oasis, Egypt. In an interview in 2014, Eng. Omar Hosny, the project manager and initiator, described the project as a community-based sustainable project. Hosny and four other volunteers raised funds from the Rotaract club to provide electricity for 60 people (Rotaract Club, 2013). Hosny also stated the community-based planning process of this project took one year of community involvement. Accordingly, the project team held various community meeting where they introduced the types of P.V. solar cells and helped the residents to decide their energy needs and preferable system. In terms of economic aspects the residents agreed to pay 1 EGP daily per house to secure money for the maintenance and spare parts. In terms of technical aspects, the initiators selected four volunteers from the village and trained them for one month on the system

installation, troubleshooting and equipment renewal. Through this training, they became the key persons for the installation and maintenance process.

The two case studies emphasize economic and technical aspects within a community-based planning process. These facets are consistent with the Stremke framework of sustainable energy planning. The next part will reflect on Qarat Um Elsaghir's NREA electricity generation project and will evaluate the sustainability planning considerations.

## **Providing Electricity for Qarat Um Elsaghir as a Governmental Approach**

### The Context

Qarat Um Elsaghir, is a village in the Western desert of Egypt, located south west of the Qattara Depression. The distance measures around 270 Km away from both Matrouh and Siwa, as shown in Figure 2. From 1983 until now, the government has been providing the residents with new modern houses, a paved road, a clinic, a school and a mosque (El-Wagieh, 2014).

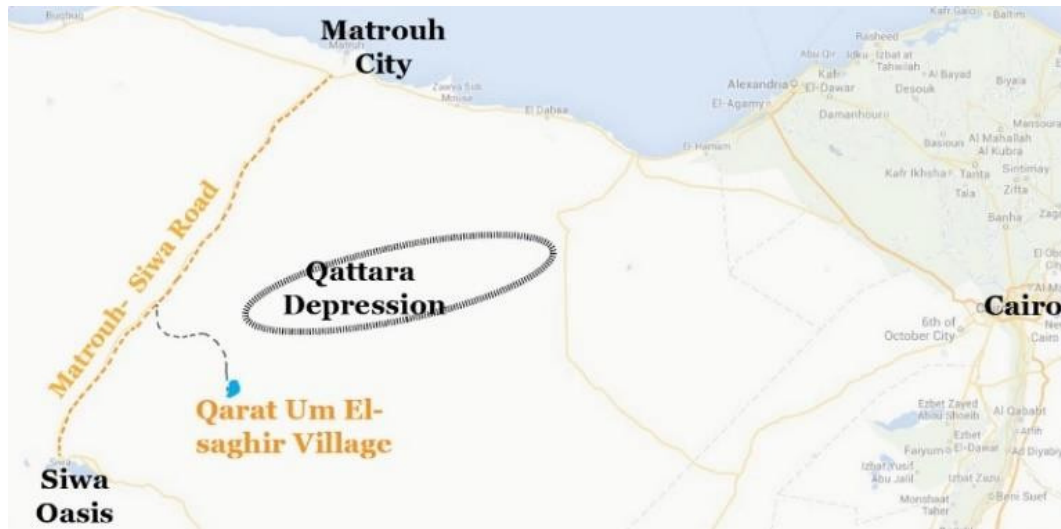

**Figure 2:** Accessibility of the Village (El-Wagieh, 2014).

Table 1 provides some technical information about the P.V. panels that were provided to the households in Qarat Um Elsaghir.

**Table 1:** Information about the PV panels provided to the village (El-Wagieh, 2014)

	Loads	Number / house	Hours/day / house	Panels/ house	Total WP/ house
<b>75 Houses</b>	Saving Lamps	5	5	2	244
	T.V	1	4		
	Saving Lamps	4	3	4	688
	Sterilizer	1	1		
	vaccine	1	7		
	Computer	6	3		
	Printe	1	1		
	Saving Lamps	2	3		
	T.V	1	3		
	VR	1	3		
<b>Mosque</b>	Saving Lamps	5	5	2	322
	Loud Speaker	1	4		
<b>30 Lighting Poles</b>				1	120

The energy sector has been rapidly developing in the village within the past 30 years. For instance, the residents shifted from burning wood and farming wastes to diesel generators provided by the state in the middle of 1980s for limited hours a day (Bakr, 2014). By 2010, the NREA implemented a P.V. solar energy electricity generation project for the houses, service buildings and inner roads. As mentioned by the NREA in 2010, the project was funded in cooperation with the Italian Ministry of Environment, Land and Sea. It covered the 75 houses existing at that time as follows:

Community-Based Evaluation to the Introduced P.V. System

In a previous research conducted by the authors aiming at evaluating the impact of the introduced P.V. systems, one can read that the resident's perception towards their landscape. The residents mentioned various deficiencies and drawbacks in the introduced systems, which consequently affected their opinions. In terms of technical aspects, the residents raised concerns related to the efficiency and performance of the produced system. They stressed on the need for more P.V. panels to operate the other appliances, such as washing machines, fans and refrigerators. Additionally, there were neither local committees nor external technicians in the village monitoring and maintaining the P.V. systems. Furthermore, no response was received from NREA towards the frequent municipality reports, which led to the accumulation of the broken down systems (Bakr, 2014). Accordingly, nine houses' systems and 13 lighting poles broke down (Bakr, 2015). This was consistent with the absence of plans concerning the future expansion and maintenance of the introduced P.V. system in the provided NREA documents. In terms of economic aspects, the costs and means of funding the maintenance of the system are unclear. On the one hand, the P.V. system was introduced to the residents for free without any

past or future financial obligations. Accordingly, the residents were neither aware of the system components nor the cost of the spare parts. On the other hand, the fund was dedicated for the initial costs of purchasing and installing the system (NREA, 2012), while the running costs for monitoring and maintenance were not included. Eventually, the residents' trust towards the decentralized P.V. system decreased significantly where the majority of the participants in the community meetings chose the centralized P.V. solar farms (El-Wagieh, 2014). For them, the centralized P.V. system is perceived as a complicated system, which will require the presence of permanent technical team to maintain it immediately. Concerning the public awareness and participation, it is worth mentioning that the community was included in introductory meetings to get acquainted with the introduced P.V. system and were consulted in the lighting poles allocation process (Bakr, 2014). However, the residents did not receive any training to know how to be responsible for their own systems. They were trained to know how to clean the P.V. panels only.

Based on these concerns, the introduced system in general appears to lack appropriate planning that enables sustaining it. In fact, this deficiency threatens the integration of the P.V. technology within the community. It demonstrates that it should be a community choice instead of an external intervention.

### **3. PROPOSED PRELIMINARY MODEL**

Reflecting on the previous three case studies, the different deficiencies that were found in Qarat Um Elsaghir existed due to neglecting the sustainable energy planning criteria. Meanwhile, the success of other two case studies could be significantly related to the developed sustainable energy planning that took place. On the one hand, the economic criteria are taken into account in the due care taken to plan a financial mechanism. This secures energy equality for all the users and provides an affordable energy solution for the residents. On the other hand, the importance of the technical criteria was pinpointed in securing a technical support team and the accessibility of spare parts.

By contextualizing the conceptual framework of Stremke, community inclusion criteria that includes participation and ownership, was significant in driving the sustainability of the P.V. systems in the different case studies. This is due to the remoteness of the villages. This remoteness strengthens the bond between the residents and affects their perception. Additionally, a managerial criteria in the context of remote areas appeared as an important aspect. As shown in the case of Qarat Um Elsaghir, the absence of local or state managerial committee responsible for running, monitoring and communicating the problems led to a failure in running the P.V. system long-term. Meanwhile, the presence of local key persons tasked with monitoring and maintaining the system in West Africa and El Heiz projects led to a sustainable running process for the P.V. systems. Accordingly, the urgency of that managerial aspect is clear from the remoteness of the villages, which requires a thorough planning and responsibilities distribution prior to the implementation. For that matter, Figure 3 represents a modified relation between the group criteria for a preliminary proposed model for a sustainable energy landscape contextualized in the realm of remote areas where a fifth criteria for managerial aspect is added to it. Moreover, the nature of the remote areas emphasizes on assigning a community inclusion core circle in the middle containing the aspects of community participation and ownership.



**Figure 3:** Schematic representation of relations between groups of criteria for sustainable energy landscape in remote area planning. Source: Authors

#### 4. CONCLUSION

This preliminary model is an attempt to incorporate the different aspects that would achieve a sustainable energy landscape in the remote areas. These aspects are highly important due to the nature of the remote areas, which require introducing simple technology that can be managed independently and be integrated within the community. It is worth mentioning that the environmental criteria were not considered during analyzing the case studies. Accordingly, their appropriate size in the model is questionable and requires further research specifically in the case of P.V. solar panels in remote areas.

#### REFERENCES

- Assogba, C., 2014:** *A Solar Revolution in West Africa's Villages*. SciDev.Net. Accessed from <http://www.scidev.net/global/energy/feature/solar-revolution-west-africa-villages.html> (29 August 2015).
- Bakr, M., 2014:** *Personal Communication*. Qarat Um Elsaghir Municipality Official, Interviewed by Aya El-Wagieh (24 February 2014).
- Bakr, M., 2015:** *Personal Communication*. Siwa Municipality Official, Interviewed by Aya El-Wagieh (10 August 2015).
- Economic Research Portal, 2013:** *Egypt Crisis in the Energy Sector*. Eco Emerging. BNP Paribas, October, 20–21. Accessed from <http://economic-research.bnpparibas.com/Views/DisplayPublication.aspx?type=document&IdPdf=23025> (29 August 2015).
- El-Wagieh, A., 2014:** *Landscape Aesthetics and the Introduction of Solar Energy Farms in the Western Desert of Egypt Elsaghir*. Village Landscape Aesthetics and the Introduction of Solar Energy Farms in the Western Desert of Egypt, Visual Public Preference Evaluation in Stuttgart University and Ain Shams University.

**Hosny, O., 2014:** *Personal Communication*. El Heiz Electrification Project's Team Manager. Interviewed by Aya El-Wagieh (19 March 2014).

**NREA, 2010:** *Final Report for Photovoltaic- Powered Lighting Systems for Two Villages*. Matrouh Governorate/Cairo.

**NREA, 2012:** *New and Renewable Energy Authority Annual Report 2011/2012*. Cairo.

**NREA, 2013:** *New and Renewable Energy Authority Annual Report Annual Report 2012/2013*. Cairo.

**Rotaract Club, 2013:** Tanweer el Heiz. *Rotaract Club of Cairo Royal*. Accessed from [http://www.rotaractcaioroyal.org/Tanweer elHeiz.htm](http://www.rotaractcaioroyal.org/Tanweer%20elHeiz.htm) (10 May 2014).

**Stremke, S., 2013:** Energy-Landscape Nexus : Advancing a Conceptual Framework for the Design of Sustainable Energy Landscapes, *Proceedings of the ECLAS Conference 2013*, 1–5.

**U.S. Energy Information Administration, 2013:** *Egypt*. Accessed from: <http://www.eia.gov/countries/cab.cfm?fips=EG#note> (10 May, 2014).

# The Feasibility of Solar Water-Pumping in a Rural Village of Malawi

Authors: Esther Phiri<sup>1,2</sup>; Paul Rowley<sup>1</sup>; Richard Blanchard<sup>1</sup>

<sup>1</sup> Center for Renewable Energy Systems Technology (CREST), Loughborough University  
Loughborough, United Kingdom

<sup>2</sup> Corresponding author: [e.phiri@lboro.ac.uk](mailto:e.phiri@lboro.ac.uk) or [ephiri@poly.ac.mw](mailto:ephiri@poly.ac.mw)

## ABSTRACT

Though Malawi has achieved and exceeded the Millennium Development Goals (MDGs) water target, over half of the people in rural areas collect water from boreholes or rivers. In spite of boreholes qualifying as improved water sources, studies show that the drinking water from these sources was contaminated and likely to cause disease. Other potable water problems include the long distances needed to collect water and gender disparity in that the majority who collect water are women. As for hand-pumps, they are manually straining and most of them break and are not repaired sometimes, even for minor faults. This makes the people resort to collecting water from their previous contaminated water sources. Electric-powered pumps can play a significant role in the provision of potable water either by increasing the depth of well or by purifying water obtained from shallow wells or rivers. With no grid electricity available in most of the rural areas, vulnerability to oil prices, depletion of fossil fuels, and high maintenance cost of diesel systems, renewable energy technologies provide a more viable alternative. A techno-economic feasibility study was carried out for a case study village: Nlukla Village, Chiradzulu District in Malawi. Results show that with favorable sunlight conditions, a solar water pumping system is a viable option for the area. The study is ongoing and future studies include working towards addressing the issue of high initial costs and how to make the system sustainable.

*Keywords: Potable Water, Solar Water-pumping, Malawi, Techno-economic Analysis, Renewable Energy*

## 1. INTRODUCTION

In 2000, the United Nations put forward eight goals called the Millennium Development Goals (MDGs) to be achieved by 2015. Target 10 of goal 7 of the MDGs was to halve by 2015, the proportion of people without sustainable access to safe drinking water and basic sanitation. Though the global MDG drinking water target was met five years ahead of the target date, 768 million people still drew water from an unimproved source in 2011 and 636 million of these lived in rural areas (United Nations, 2013). Malawi also achieved and exceeded the water target and the Government of Malawi reported that by 2015, about 94 percent of population was likely to have sustainable access to improved water source (Malawi Government, 2010). However, just like on the global scene the rural-urban divide persists; with a majority of the people in rural areas still collecting water from boreholes or surface water. In spite of boreholes qualifying as improved water sources, the quality and safety for many of them is questionable, as many of them break. Electric pumping can make a difference by making the boreholes deeper for safer water. Lack of grid electricity in rural areas and high cost of fossil fuels make renewable energy technologies (RETs) the best option for water pumping. At the same time RETs can provide mitigation and adaptation to climate change. Hence the objective of this

study is to determine the feasibility of solar water pumping using renewable energy. The study will focus in rural areas where the majority of the population (85 %) lives and has less access to services such as water, health, education, and telecommunications as compared to those living in urban areas.

## **2. BACKGROUND OF DRINKING WATER SITUATION IN RURAL AREAS OF MALAWI**

The Malawi Demographic and Health Survey Report (National Statistical Office, 2011) found that the proportion of the rural population that has access to an improved source of drinking water is 77.1 %, whereas 22.6 % of the rural population still access water from non-improved sources and the rest (0.3 %) from other sources. The World Health Organization (WHO, 2006), defines improved water sources to include household connections, public standpipes, boreholes, protected dug wells, protected springs, and rainwater collection; providing they are within 'reasonable access' (WHO and UNICEF, 2000).

For rural water supply systems, groundwater is generally preferred as a drinking water source because the cost of extracting groundwater is less than that of treating surface water. Also, water pumped from shallow wells can easily be contaminated from human and animal activities. Finally, shallow wells have limited yield because they are dependent on seasonal rainfall unlike deeper wells that are less affected by that factor. Several other factors such as latrines, septic tanks, refuse dumps, cattle kraals, dip tanks and cemeteries have a great impact on the quality of the groundwater, and hence consideration of these has to be taken (Kanyerere, 2012; Taylor, 2012).

In Malawi studies on water resources and water quality in particular are limited (Mapoma, 2014; Robins, 2013). Early studies of groundwater (Chilton, 1984) recorded that the availability of groundwater resources in Malawi was associated with two major aquifer types: the Precambrian crystalline weathered basement complex aquifer which makes up approximately 70 % of Malawi's landscape and the Quaternary alluvial deposits. Groundwater levels in the basement aquifers are in most cases less than 15 m below surface, with seasonal fluctuations of typically 1 to 5 m.

It has been shown that the shallow wells of Chiradzulu yielded water of unacceptable microbiological quality and that the situation was significantly worse in the wet season (Pritchard, 2007). This is because the form of construction and method of water extraction for these wells was insufficient to yield potable water. On the other hand, the physical and chemical parameters were generally close to or within the WHO or National guidelines standards and did not change significantly with seasons. Conventional water treatment technologies such as chlorine were unaffordable and unsustainable for rural livelihoods. It was also noted that a number of wells dry up during the dry season, which in turn forces people to use open water sources such as rivers which are even more contaminated. On the other hand, hand-pumps are a physical burden to women who usually collect water and at the same time are involved in other domestic chores. Cholera and diarrhea are the common water-related diseases prevalent in the country. The major likely cause of these diseases is drinking contaminated water collected from shallow wells, lakes, rivers and other unprotected sources (Kamanula, 2014; Khonje, 2012; Moren, 1991; Masangwi, 2009; Swerdlow, 1997).



### **3. WATER PUMPING USING RENEWABLE ENERGY**

The availability of abundant renewable resources makes RETs very competitive for water pumping in rural areas of developing countries, where fossil fuels are expensive and where it is usually challenging to extend the grid. Following a review of over a hundred renewable energy water pumping systems used for both irrigation and domestic use, it was found that solar photovoltaic followed by wind energy are the mostly widely used RETs for water pumping (Gopal, 2013). They concluded that RETs play a vital role in reducing consumption of conventional energy sources and that their environmental impacts are negligible. For storage methods they recommended water tanks and/or batteries. It was also found that it could be more cost effective to use photovoltaic water pumping systems instead of diesel engines to energize pumping systems in Jordan Badia (Al-Smairan, 2012). For Nigeria, solar and wind based systems were recommended over petrol, and wind was less favored because of less resource availability and lack of suppliers (Cloutier, 2011). In widely distributed populations, they recommended hand pumps and batteries and/ or pump storage tank for storage. Other authors also recommended solar PV (Kaldellis, 2011; Meah, 2008; Ould-Amrouche, 2010). In high wind regions, wind was generally recommended over solar and diesel, and because wind is intermittent, use of a reservoir tank for storage was advised (Al-Suleimani, 2000; Biswas, 2011; Bouzidi, 2011; Omer, 2001). Solar PV was cited as the most advantageous system despite its high capital costs, with environmental friendliness and low O&M requirements topping the list of advantages. Wind came second with advantages of minimal maintenance as compared to the diesel systems and also that unlike solar PV, it was not prone to theft. Diesel systems' main disadvantages were high fuel costs and need for maintenance, though the capital costs are comparatively low.

In Malawi, the existing renewable energy potential (apart from large hydro) is very poorly utilized. With less than 10 % of the population connected to the electricity grid, RETs are a viable option for water pumping in the rural areas (Gamula, 2013).

### **4. CASE STUDY**

Nlukla is a village in Chiradzulu district in the Southern Region of Malawi. The district is the second most highly populated district in the region, whilst at the same time being one of its poorest despite lying only 25 km away from the commercial city of Blantyre (National Statistical Office, 2010). The area has no access to grid power and with low wind speeds, solar was chosen over wind. The current water supply is a 6 m deep elephant pump with maximum total fecal coliforms of 5, 820 Total Coliforms /100 ml in the wet season (Pritchard, 2007) .

#### **System Design**

A 50 m deep borehole with storage tanks and public taps fed by gravity was proposed and designed for a population of 820 people. The daily usage was calculated from a WHO/UNICEF recommendation of 20 liters per person per day. The monthly averaged sunlight hours for the study area as obtained from NASA Website is given in Table 1. The month with the least amount of radiation for the study area is June, with a radiation of 4.34kWh/m<sup>2</sup>/day.

**Table 1:** Monthly Averaged Insolation Incident on a Horizontal Surface (kWh/m<sup>2</sup>/day) for Chiradzulu positioned at Latitude 15.676 and Longitude 35.141 (NASA, 2014)

Month	Jan	Feb	Mar	Apr	May	Jun	Jul	Aug	Sep	Oct	Nov	Dec	Ann Avg
22 yr avg	5.32	5.46	5.43	5.19	4.84	4.34	4.48	5.26	6.21	6.49	6.12	5.43	5.38

The estimated dynamic Head (h) was estimated to be 70 m. The sizing of PV array in terms of hydraulic power and solar irradiation is given by (Argaw, 2004) :

$$P = 1000 \frac{\rho g h V \eta_r}{G_T \eta_{pv} \eta_s}$$

where P is the electric power of the PV array, ρ is the density of water, g is the acceleration due to gravity, h is the total pumping head (m), G<sub>T</sub> is the daily solar radiation on the PV array surface (kWh/m<sup>2</sup>), η<sub>r</sub> is the array efficiency at the reference temperature (T<sub>r</sub> = 25 °C), η<sub>pv</sub> the PV array efficiency under the operations conditions, and η<sub>s</sub> the subsystem efficiency.

From the calculated results the following components were selected: 10 solar modules of 100 W<sub>p</sub> each, 1 Grundfos SQF 2.5-2 Submersible Pump and 4 storage tanks of 10,000 liters each. The cost of the system is given in Malawi Kwacha as shown in in Table 2 (as of 31 August 2015, US\$ 1= MWK 561).

## Economic Analysis

### Simple Payback

Simple Payback was calculated as:

$$\text{Simple Payback (yrs)} = \frac{\text{Cost of installed system}}{\text{Net annual cash inflow}}$$

**Table 2:** Solar Water Pumping System Costs and Results

Capital Costs	Cost (MWK)
Solar Modules	1,170,000.00
Pump	1,196,715.00
Accessories & Labour	442,843.48
Well Drilling	2,500,000.00
Pipework & Taps	250,000.00
Tanks and tank stands	4,000,000.00
Labour & Administration	300,000.00
<b>Total</b>	<b>8,689,558.48</b>
<b>Operation &amp; Maintenance</b>	
Pump Replacement (10yrs)	1,196,715.00
Annual Maintenance	120,000.00
<b>Results</b>	

Simple Payback	9.56 years
Net Present Value	-MWK 4,989,131.69

### Net Present Value

Using Microsoft Excel, the life cycle costs (LCC) was calculated for an assumed 20-year period taking into account capital cost, operating and maintenance costs, and replacement costs. The Net Present Value (NPV) was calculated by selecting a discount rate of 35 % in line with the borrowing interest rate in Malawi. The net present value is given as:

$$NPV(i, N) = \sum_{t=0}^N \frac{R_t}{(1 + i)^t}$$

Where  $t$  is the time of the cash flow,  $R_t$  is the net cash flow at the time, and  $N$  is the total number of years. The results were obtained for simple payback, while net present value and cost of water are presented in Table 2.

### CONCLUSIONS

The simple payback period is 9.6 years, which is shorter than the useful life (20 years). This suggests the solar pumping system will pay for itself before it stops working. The NPV, however, is negative suggesting that, accounting for the time value of money, there will be a loss. With the high interest rate used in the country, this should be expected. For the people living in rural areas of Malawi these costs are exorbitantly high, hence a system has to be devised on how to cover these costs, which is recommended as future area of research for this study.

Apart from designing a solar water pumping system for irrigation; the other recommended future area of research for this study is to design a financing mechanism to cover for the high capital costs, bearing in mind that for the people living in rural areas of Malawi the capital costs are exorbitantly high.

## REFERENCES

- Al-Smairan, M., 2012:** Application of Photovoltaic Array for Pumping Water as an Alternative to Diesel Engines in Jordan Badia, Tall Hassan Station: Case Study, *Renew. Sustain. Energy Rev.*, 16(7), 4500–4507.
- Al Suleimani, Z. and Rao, N.R., 2000:** Wind-Powered Electric Water-Pumping System Installed in a Remote Location, *Applied Energy*, 65(1-4), 339–347.
- Argaw, N., 2004:** *Renewable Energy Water Pumping Systems Handbook*. National Renewable Energy Laboratory, Denver. Accessed from <http://www.nrel.gov/docs/fy04osti/30481.pdf> (1 December 2015).
- Biswas, W.K., 2011:** Application of Renewable Energy to Provide Safe Water from Deep Tubewells in Rural Bangladesh, *Energy Sustainable Development*, 15(1), 55-60.
- Bouzidi, B., 2011:** Viability of Solar or Wind for Water Pumping Systems in the Algerian Sahara Regions – Case Study Adrar, *Renewable Sustainable Energy Review*, 15(9), 4436–4442.
- Chilton, P.J. and Smith-Carrington, A.K., 1984:** *Characteristics of the Weathered Basement Aquifer in Malawi in Relation to Rural Water Supplies*. IAHS Press, Wallingford, Oxfordshire, UK.
- Cloutier, M. and Rowley, P., 2011:** The Feasibility of Renewable Energy Sources for Pumping Clean Water in Sub-Saharan Africa: A Case Study for Central Nigeria, *Renewable Energy*, 36(8), 2220–2226.
- Gamula, G.E.T, Hui, L. and Peng, W., 2013:** Development of Renewable Energy Technologies in Malawi, *International Journal of Renewable Energy Technology Research*, 2(2), 44–52.
- Gopal, C., Mohanraj, M., Chandramohan, P. and Chandrasekar, P., 2013:** Renewable Energy Source Water Pumping Systems - A Literature Review, *Renewable Sustainable Energy Review*, 25(25), 351-370.
- Kaldellis, J.K., Meidanis, E. and Zafirakis, D., 2011:** Experimental Energy Analysis of a Stand-Alone Photovoltaic-Based Water Pumping Installation, *Applied Energy*, 88(12), 4556–4562.
- Kamanula, J.F., Zambasa, O.J. and Masamba, W.R.L., 2014:** Quality of Drinking Water and Cholera Prevalence in Ndirande Township, City of Blantyre, Malawi, *Physics and Chemistry of the Earth, Parts A/B/C*, 72-75, 61-67.
- Kanyerere, T., Levy, J., Xu, Y. and Saka, J., 2012:** Assessment of Microbial Contamination of Groundwater in Upper Limphasa River Catchment, Located in a Rural Area of Northern Malawi, *Water SA*, 38(4), 581–596.

**Khonje, A., Metcalf, C.A., Mlozowa, D.D., Akesson, A. and Corbet, T., 2012:** Cholera Outbreak in Districts around Lake Chilwa, Malawi: Lessons Learned, *Malawi Medical Journal*, 24(2), 29–33.

**Malawi Government, 2010:** 2010 Malawi Millennium Development Goals Report,” 2010. Accessed from <http://planipolis.iiep.unesco.org/upload/Malawi/MalawiMDGs2010Report.pdf> (1 December 2014).

**Mapoma, H.W.T. and Xie, X., 2014:** Basement and Alluvial Aquifers of Malawi: An Overview of Groundwater Quality and Policies, *African Journal of Environmental Science and Technology*, Accessed from [http://www.academicjournals.org/article/article1394534763\\_Mapoma\\_and\\_Xie.pdf](http://www.academicjournals.org/article/article1394534763_Mapoma_and_Xie.pdf) (1 December 2014).

**Masangwi, S.J., Morse, T.D., Ferguson, N.S., Zawdie, G., Grimason, A.M. and Namangale, J.J., 2009:** Behavioural and Environmental Determinants of Childhood Diarrhoea in Chikwawa, Malawi, *Desalination*, 248(1-3), 684–691.

**Meah, K., Ula, S. and Barrett, S., 2008:** Solar Photovoltaic Water Pumping – Opportunities and Challenges, *Renewable Sustainable Energy Review*, 12(4), 1162–1175.

**Moren, A.M., Bitar, D., Navarre, I., Etchegorry, M.G., Brodel, A., Lungu, G., and Hakewill, P., 1991:** Epidemiological Surveillance Among Mozambican Refugees in Malawi, 1987-89, *Disasters*, 15(4), 363-372.

**National Statistical Office (of Malawi), 2010:** *Population and Housing Census 2008*. Zomba.

**National Statistical Office (of Malawi), 2011:** *Malawi Demographic and Health Survey*.

**NASA, 2014:** *NASA Surface Meteorology and Solar Energy – Choices*. Accessed from <https://eosweb.larc.nasa.gov/cgi-bin/sse/grid.cgi?&email=skip@larc.nasa.gov&step=1&p=&lat=-15.676&submit=Submit&lon=35.141>. (2 December 2014).

**Omer, A.M., 2001:** Wind Energy in Sudan: Water Pumping in Rural Areas, *Refocus*, 2(8), 34–37.

**Ould-Amrouche, S., Rekioua, D. and Hamidat, A., 2010:** Modelling Photovoltaic Water Pumping Systems and Evaluation of their CO<sub>2</sub> Emissions Mitigation Potential, *Applied Energy*, 87(11), 3451–3459.

**Pritchard, M., Mkandawire, T. and O’Neill, J.G., 2007:** Biological, Chemical and Physical Drinking Water Quality from Shallow Wells in Malawi: Case Study of Blantyre, Chiradzulu and Mulanje, *Physics and Chemistry of the Earth, Parts A/B/C*, 32(15-18), 1167-1177,

**Robins, N., Davies, J. and Farr, J., 2013:** Groundwater Supply and Demand from Southern Africa’s Crystalline Basement Aquifer: Evidence from Malawi, *Hydrogeology Journal*, 21(4), 905–917.

**Swerdlow, D. L., Malenga, G., Bergkoyian, G., Nyangdulu, D., Toole, M., Waldman, R.J., Puh, D.N.D., and Tauxe, R.V., 1997:** Epidemic Cholera among Refugees in Malawi, Africa: Treatment and Transmission, *Epidemiological Infections*, 118(3), 207–214.

**Taylor, H., Chavula, G., Ebdon, J., Phillips, R. and Kapudzama, O., 2012:** *Assessment of Drinking Water Quality for Low-cost Water Options in Rural Malawi Technical Annex November 2012*. November.

**United Nations, 2013:** *The Millennium Development Goals Report 2013*. Accessed from <http://www.un.org/millenniumgoals/pdf/report-2013/mdg-report-2013-english.pdf> (1 December 2014).

**WHO, 2006:** *Guidelines for Drinking-Water Quality*. Accessed from [http://www.who.int/water\\_sanitation\\_health/dwq/gdwq0506.pdf](http://www.who.int/water_sanitation_health/dwq/gdwq0506.pdf) (1 December 2014).

**WHO & UNICEF, 2000:** *Global Water Supply and Sanitation Assessment 2000 Report*.

# Techno-Economic Feasibility of PV Irrigation in Egypt

Hany Abd ElRehim (Hanyhelaly@hotmail.com)

Technische Universität Berlin, Zentralinstitut ElGouna  
Sekt. FH 5-1, Fraunhoferstr. 33-36, 10587 Berlin, Germany

## ABSTRACT

Egypt's Delta and Valley, with the highest population and agriculture density in Egypt, is susceptible to the depletion of its Nile through flood irrigation and inundation attributed to climate change scenarios. To mitigate risks, the government reclaimed circa 3 million acres for agriculture utilizing underground water as well as excess solar energy for powering the irrigation. Through a techno-economic model, this paper gages the feasibility trends of PV pumping over dominant subsidized diesel in geographic areas of potential utilizing discounted payback period, and unit water costs of water as an objective function. It was found that PV pumping is feasible at low hydraulic loads and tends to be less attractive with increasing hydraulic loads.

**Keywords:** PV Irrigation; Solar Pumping; Egypt

## 1. INTRODUCTION

Agriculture in Egypt exhibits the highest employment rate of 55% indirectly and 30% directly, while also accounting for 17% of the GDP and 20% of all foreign exchange earnings (Boers, 2013). 65% of agriculture activities along with 99% of the population are located in the Nile Delta, making use of the Nile River which accounts for 76.7% of Egypt's available water resources through flood irrigation mostly (UNEP, 2010). The immense water consumption pushed Egypt to the water poverty limit and with the current water demand trends, it is projected that Egypt would require twice the current share of the Nile water by the year 2050 (Salim, 2012). The US department of trade report that the Egyptian water pump market is among the largest in the world, and although the Nile Delta is connected to a heavily subsidized national grid pricing scheme of 0.015 US\$/Kwh, diesel driven pumps dominate the irrigation market (UNEP, 2003). This is attributed to the unreliable grid and subsidized diesel at 65% which burden the Egyptian government, with 21% of the national budget allocated to energy subsidies (Castel, 2012). Moreover, diesel is among the highest CO<sub>2</sub> emitting fuels that drives climate change. According to (Tolba and Saab, 2009), a 1 m sea level rise would flood 34% of the Delta, displacing about 8.5% of the population and jeopardizing 12% of Egypt's agricultural land hence food security. Having realized that, the government reclaimed more than 3 million acres and considering the available underground water aquifers plus treated water; the second available water resource with a 28% for irrigation (Tolba and Saab, 2009). As for powering irrigation pumps, a huge subsidy was removed and diesel prices increased by circa 66% to favor Egypt's solar conditions reaching 3,900 sunshine hours and above 2,600 Kwh/m<sup>2</sup> (Globalpetrolprices, 2014; Salim, 2012). As a preference, farmers tend to purchase the high

recurrent cost pumping systems rather than high capital cost ones (Fraenkel, 1986). In addition, with little publications on the economic feasibility of PV pumps in Egypt, farmers remain skeptical of the return on such investments in absence of incentives. PV (photovoltaic) driven pumping demonstrated its technical and commercial feasibility elsewhere. Nonetheless, feasibility studies in the literature considered either economic or technical feasibility of PV irrigation, and mostly, the studies were rather system size and/or location specific. A method for sizing a PV irrigation system based on; climate, geographic location, soil quality and crop water requirements was applied near Badajoz, Spain (Gajić et al., 2013) considering only economic indicators. Kelley et al. (2010) developed a general method to determine the technical and economic feasibility of PV irrigation systems, but exclusive of irrigation application and storage scenarios.

## **2. RESEARCH OBJECTIVES**

This paper attempts to devise a generalized approach to assess the feasibility and cost trends of standalone PV underground water pumping against diesel driven pumping, in addition to simulating the behavior of both pumping systems under the current Egyptian economic status and various farming sizes within geographical areas of potential. Most importantly, it assesses the factors with the most impact on the PV pumping feasibility and unit water costs (UWC), and highlights the potential CO<sub>2</sub> emissions reduction through deploying such technology. Thereby, it lays out the case for institutions and stakeholders interested in sustainable energy and agriculture.

## **3. METHODS**

The system is feasible when the PV driven pump's unit water costs (UWC) are less than the diesel driven ones. A set of technical and economic parameters were identified in a mathematical model with formulas to simulate the PV and diesel pumping configurations. Those simulations were then, combined in an objective function; (UWC).

PV pumping is technically feasible when common system configurations are assembled in available land areas accommodating the system size (Kelley et al., 2010). Sizing of the PV and diesel pump is a function of geographical location in Egypt, field area and the crop type storage and irrigation application. The geography entails available solar energy and aquifer depth while the crop type and irrigation application determine the irrigation water requirement and storage. The economical assessment of the pumping systems makes use of the total revenue requirement (TRR) approach to truly reflect the incurred costs over the lifetime of the two pumping systems. This approach is commonly used when comparing a renewable energy system and a conventional one serving the same purpose. Another indicator was the payback period based on a discounted cash flow (DCF). Parameters of major contribution to the lifetime cost of the pumping systems are varied with reference to a base case in a sensitivity analysis to assess the trends of the UWCs.



## Technical study

### Configuration & Operating range

A standalone PV pumping system, as shown in **Figure 8** with a maximum hydraulic load of 4,620 m<sup>4</sup>/hr (Figure 1). The Hydraulic load (HL) is simply, the product of the flow rate and the total dynamic head. It is a useful tool since unlike energy systems of (Kwh), pumps have 2 parameters; head and flow. The configuration constitutes of;

- A PV array
- A Brushless DC (Direct Current) motor in conjunction with a submersible pump, making use of a low maintenance and high efficiency combination and avoiding inverters' capital cost within the hydraulic load range of this paper. Lorentz PS and PSK2 series are the models of choice. Operating ranges as a function of hourly hydraulic load were derived from Lorentz

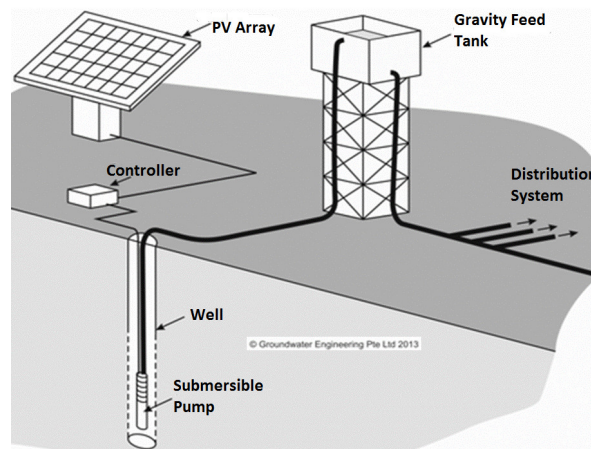

**Figure 1:**

- A Gravity feed tank to store water rather than batteries, the latter having higher investment and maintenance costs. The storage capacity is dependent on storage at the root zone of the crop which is in turn dependent on many factors (soil, cropping pattern, climate, etc.) outside the scope of this paper (Glasnovic and Margeta, 2007). In this paper, water is pumped from a water source to a gravity tank to equate pressure and account for night pumping hours, if required. Gravity tanks are elevated to overcome friction losses in the distribution system.
- The distribution system in agriculture is the irrigation application. Drip systems complement PV irrigation owing to their high water application efficiency and low heads. Application efficiency is the useful amount of water delivered to the crops on field while, application head is the pressure head required to overcome friction forces. A combination of low efficiency and high head increases significantly the size of the PV system.

## Site Selection

Salim (2012) conducted a study to select suitable sites in Egypt for solar pumping of underground water. The suitability was defined based on 4 factors with different weights; solar insolation (40%), aquifer depth (30%), salinity (15%) and distance from the Delta (15%). Areas of sand dunes or rock faults and susceptible to incidence of flash flooding or seawater intrusion were excluded. The geographical parameters of the three most suitable areas are considered in the base case and sensitivity analysis. The Peak Sunshine Hours (PSH) varied from 6.4 to above 7.1 Kwh/m<sup>2</sup> and aquifer depths from a low of 25 to deeper than 350 m.

## Daily Water Requirement

The Daily water requirement for irrigation ( $Q_{PV}$ ) in (m<sup>3</sup>/day) depends on the real evapotranspiration ( $ET_r$ ) in (m/day) of the crop which is the actual water consumption of the crop per unit area ( $A_f$ ) in (m<sup>2</sup>) and application efficiency ( $\eta_{app}$ ).

$$Q_{PV} = \frac{ET_r * A_f}{\eta_{app}}$$

The pump design flow rate ( $Q_{design}$ ) in (m<sup>3</sup>/hr) is obtained by dividing ( $Q_{PV}$ ) by daily (PSH) in case of PV system, and daily pumping hours ( $H_{DP}$ ) for the diesel system (Kelley et al., 2010). In reality, the crop water requirements vary through the year. Crops need more water in their growing seasons. Thus, farmers using PV pumping are advised to plant more than one crop per year to smooth the water demand all year (Barlow, Mcnelis, & Derrick, 1993).

## Total Dynamic Head (TDH)

$TDH_{PV}$  = Aquifer depth + Vertical rise + Friction losses

The vertical rise in (m) is the vertical distance from ground level to inlet of the storage tank.

$$\text{Vertical rise} = \text{Tank elevation} + h_{Tank}$$

Tank elevation builds sufficient pressure head to overcome friction losses in the distribution system inlet pressure as a function of unit inlet pressure  $U_{IP}$  in (m/m<sup>2</sup>).

$$\text{Tank elevation} = \text{drip inlet pressure} = U_{IP} \times A_f$$

An increase in tank height increases TDH and ultimately pumping costs. Height to diameter ratio ( $h_{Tank}/d$ ) of gravity feed tanks should reflect wide and short design (Barlow et al., 1993).

$$\text{Tank storage capacity} = \pi (d/2)^2 h$$

The TDH of the diesel system is the same as the PV one excluding ( $h_{Tank}$ ).

## Hydraulic Energy and PV array size

The solar field area ( $A_s$ ) in (m<sup>2</sup>) and PV generator peak power ( $P_{PV}$ ) in (KW<sub>P</sub>) are given by (Al-Smailan, 2012) and (Kelley et al., 2010)

$$HE = 0.002725 \times TDH_{PV} \times Q_{PV} = 0.002725 \times HL$$

$$P_{PV} = \frac{HE}{PSH \times \eta_{sub}} \times SF, \& A_s = \left( \frac{P_{PV}}{I_{max} \times \eta_{PV}} \right)$$

(HE) is the Hydraulic energy in (Kwh/day), ( $\eta_{sub}$ ) is the subsystem efficiency and ( $SF$ ) is the safety factor, ( $I_{max}$ ) is the solar radiation used by the manufacturer for the PV panels power rating at standard test condition (STC) in (Kw/m<sup>2</sup>), and ( $\eta_{PV}$ ) is PV panels efficiency.

The diesel system required pumping power ( $P_P$ ) in (Kw) is divided by the load factor ( $L_F$ ) to determine the generator power rating ( $P_{Gen,rated}$ ) in (Kw) (Al-Smairan, 2012; Kelley et al., 2010). ( $\eta_p$ ) is the pump set efficiency.

$$P_P = \frac{0.002725 \times HL_{diesel}}{\eta_p}, \& P_{Gen,rated} = \frac{P_P}{L_F}$$

### Economic study

All non-uniform annual costs are levelized. Levelizing costs is converting the non-uniform annual costs to their present values and summing up to equal annual payments (annuities) over the lifetime of the project. Costs associated with components present in both pumping configurations are not included. Costs of the water distribution system, piping and well drilling are also not included in the analysis, as they are independent of the power source used. The standard cost investments of components listed in Table 1 are levelized by a capital recovery factor (CRF) to find equal amounts; annuities ( $A_{CI}$ ) equivalent to the present value ( $P$ ). ( $i$ ) is the annual discount rate and ( $n$ ) is the project lifetime.

$$A_{CI} = P \times CRF, \& CRF = \frac{i(1+i)^n}{i(1+i)^n - 1}$$

O&M and fuel costs are non-uniform yearly expenses (

**Table 1)** and usually nominal escalation rate is introduced;  $CELF = \frac{k(1-k^n)}{1-k} \times CRF$ , &  $k = \frac{1+r_n}{1+i}$ . ( $CELF$ ) is the cost elevation levelization factor relating first year expenditure ( $P_{O\&M}$ ) and an equivalent annuity ( $A_{O\&M}$ ).

**Table 1:** O&M Schedule and Costs

Maintenance event	Event frequency	Cost/event (US\$)
Minor Service	4/year	67
Major Service	2/year	530
Overhaul	10,000 hours	30% of New
Panels cleaning	1/month	$f(A_s, labor\ cost)$

#### 4. RESULTS

The base case reflects a hydraulic load of typical small scale farming of 6,000 m<sup>2</sup>, (ET) of 0.005 m/day and an aquifer depth of 60 m. The base case inputs listed in Tables 2, 3 and 4 yielded UWCs of 0.17 and 0.32 US\$/m<sup>3</sup> for the PV and diesel pumps respectively as shown in Figure 3 and a discounted payback of circa 3.5 years. Last but not least, circa 115 tons of CO<sub>2</sub> could be saved. Cost fraction analysis revealed capital cost dominance in the PV system. Usually, fuel dominate cost fractions, but within this small hydraulic load, economies of scale and subsidized diesel play a role.

**Table 2:** Technical PV Inputs

PSH	Night pumping (hours)	Storage (hours)	$h_{Tank}/d$	Distribution Friction (psi/m <sup>2</sup> )	Aquifer Depth (m)	$\eta_{sub}$ (%)	Safety Factor	$I_{max}$ , (kW/m <sup>2</sup> )	$\eta_{PV}$ , (%)
6.8	0	1	1	0.001	60	60	1.2	1	14

**Table 3:** Economic Inputs

Project lifetime (years)	PV array (US\$/ $W_p$ )	Gravity tank (US\$/m <sup>3</sup> )	Diesel pump (US\$/Kw)	Diesel Generator (US\$)	Unskilled labor, (\$/hr)	Diesel cost (US\$/Liter)	Interest rate (%)	Escalation rate (%)
20	2	200	131	$234P_{Gen} + 3400$	7	0.25	10	3

**Table 4:** Technical Diesel Inputs

$\eta_P$ (%)	$L_F$ Load Factor	$Specific_{fc}$ , (liter/KWh)	CO <sub>2</sub> emissions (Kg/KWh)	$H_{DP}$ , daily pumping (hr)
60	0.7	0.3	1.05	8

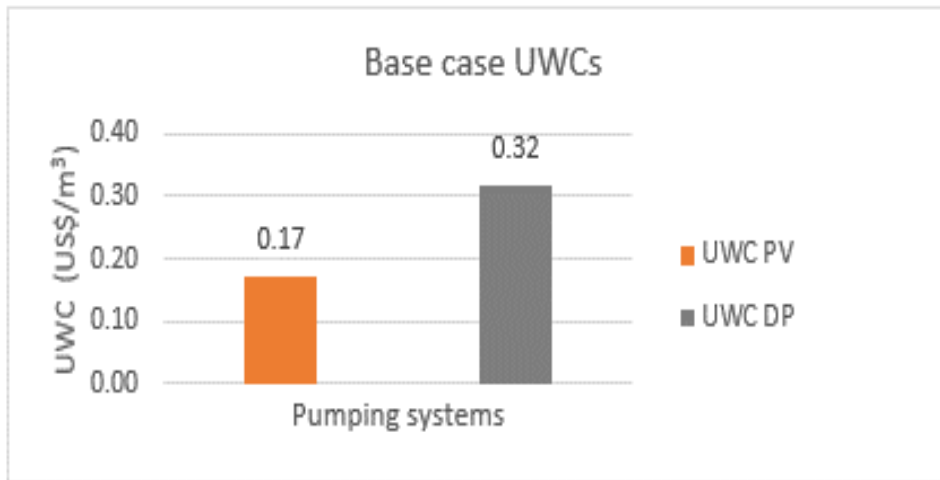

**Figure 3:** Base case UWCs.

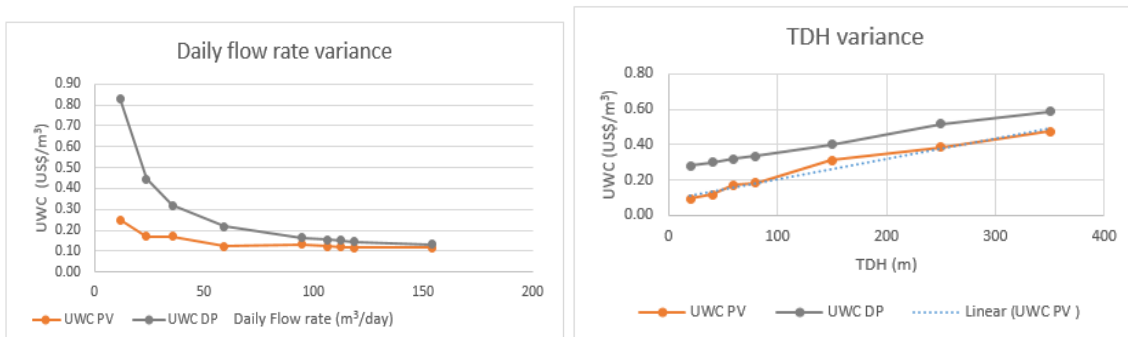

**Figure 4:** THD Variance (left) and daily flow rate variance (right).

Increasing the two components of the hydraulic loads illustrated in Figures 3 and 4 decreases the feasibility of the PV system reaching pay back periods of 12 and 15 years. Increase in TDH, increases the UWCs due to increase in capital and fuel annuities. On the other hand the daily water requirement decreases the UWCs because increased water production though the diesel system shows faster declining pace. The PV system UWCs curve are flattened by increased storage costs. Figure 5 shows the impact of the feasibility main drivers, PV array & diesel costs with significant variance in payback periods. When varying other parameters, UWCs and payback;

- UWCs & payback increase with increasing storage and night pumping hours.
- A PSH increase, decreases UWCs, but magnifies at higher hydraulic loads.
- Increasing the project lifetime decreases the PV UWCs while increasing the diesel ones.

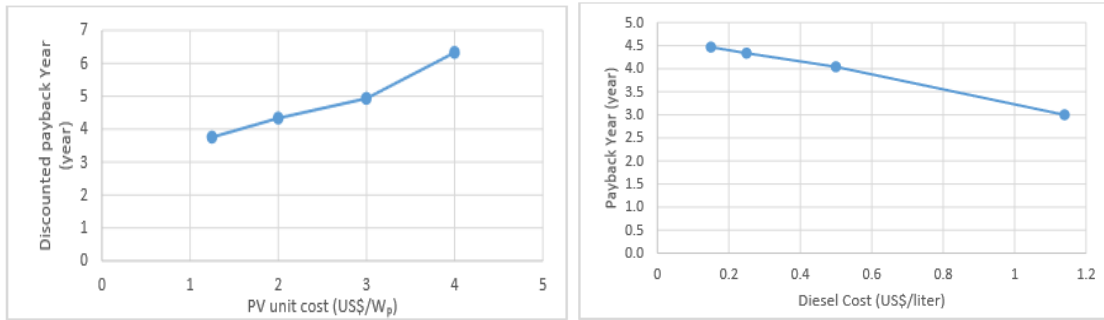

**Figure 5:** Project unit payback variance (left) and diesel unit cost variance (right).

## DISCUSSION

This paper accords with literature outcomes of PV irrigation being feasible at lower hydraulic loads and tends to be less feasible as the loads increase. In Egypt, the solar insolation brings PV UWCs down but unfortunately, so does the diesel subsidies to it UWCs. Thus, interested financing bodies should harmonize high capital investment via loans to be more in pace with negligible recurrent & recovered capital costs of long term PV pumping projects.

## REFERENCES

- Al-Smairan, M., 2012:** Application of Photovoltaic Array for Pumping Water as an Alternative to Diesel Engines in Jordan Badia, Tall Hassan Station Case Study, *Renewable and Sustainable Energy Reviews*, 16(7), 4500–4507.
- Barlow, R., Mcnelis, B., and Derrick, A., 1993:** *Solar Pumping An Introduction and Update on the Technology*, MN.
- Boers, K., 2013:** *Raseed, Green Energy in Agriculture*. Deutsche Gesellschaft für Internationale Zusammenarbeit GmbH, Bonn.
- Castel, V., 2012:** *Subsidies, Reforming Energy*. African Development Bank.
- Fraenkel, P. L., 1986:** *Water Lifting Devices*. FAO, Rome.
- Gajić, B., Tomić, Z., and Sredojević, Z., 2013:** A Simple Method: Estimates and Economic Indicators, *Economics of Agriculture*, 60(2), 223-236.
- Glasnovic, Z. and Margeta, J., 2007:** A Model for Optimal Sizing of Photovoltaic Irrigation Water Pumping Systems, *Solar Energy*, 81(7), 904–916.
- GlobalPetrolPrices, 2014:** Diesel Prices, Liter Accessed from [http://www.globalpetrolprices.com/diesel\\_prices/#Egypt](http://www.globalpetrolprices.com/diesel_prices/#Egypt) (24 February 2016).
- Kelley, L. C., Gilbertson, E., Sheikh, A., Eppinger, S. D., and Dubowsky, S., 2010:** On the Feasibility of Solar-Powered Irrigation, *Renewable and Sustainable Energy Reviews*, 14(9), 2669–2682.
- Tolba, M. K. and Saab, N. W. (eds.), 2009:** *Arab Environment : Impact of Climate Change on Arab Countries*. Report of the Arab Forum for Environment and Development, published with the Technical Publications and Environment and Development Magazine, 38-39. Accessed from [http://www.afedonline.org/afedreport09/Full English Report.pdf](http://www.afedonline.org/afedreport09/Full%20English%20Report.pdf) (15 August 2015).
- Salim, M. G., 2012:** Selection of Groundwater Sites in Egypt, Using Geographic Information Systems, for Desalination by Solar Energy in Order to Reduce Greenhouse Gases, *Journal of Advanced Research*, 3(1), 11–19.

**United Nations Environment Program (UNEP), 2010:** *AFRICA Water Atlas: Division of Early Warning and Assessment (DEWA)*. UNE, Nairobi.

**United Nations Environment Program (UNEP), 2003:** *Baseline Survey of the Renewable Energy Sector - Egypt*.

# **Renewable Energy as Sustainable Solutions for Rural Areas:**

## **Practical Examples of Renewable Energy Solutions in Rural and Urban Environments**

**Salma Lasheen**

### **ABSTRACT**

Renewable energy is generally defined as energy that comes from resources which are naturally replenished on a human timescale such as sunlight, wind, rain, tides, waves, and geothermal heat. The deployment of renewable energy is increasingly being championed as a potentially significant source of job creation OECD countries, and governments have invested large amounts of public money to support RE. A large part of this investment goes to rural regions, seen as ideal for siting RE instalments owing to the space-intensive nature of most RE technologies .

### **1. INTRODUCTION**

While many renewable energy projects are large-scale, renewable technologies are also suited to rural and remote areas and developing countries, where energy is often crucial in human development. United Nations' Secretary-General Ban Ki-moon has said that renewable energy has the ability to lift the poorest nations to new levels of prosperity. Yet experience shows that the economic benefits of RE deployment for rural communities are automatic: realizing them requires care, thought and the right policy framework. This paper seeks to clarify what kind of opportunities and challenges rural communities should expect from RE. As the hosts of alternative energy installations, rural communities bear the related costs – it is only fair that they should also reap the benefits.

### **2. MATERIALS AND METHODS**

Worldwide renewable energy capacity grew at rates of 10-60% annually for many technologies. However, grid-connected PV increased the fastest of all renewables technologies, with a 60% annual average growth rate. In 2010, renewable power constituted about a third of the newly built power generation capacities. Projections vary, but scientists have advanced a plan to power 100% of the world's energy with wind, hydroelectric, and solar power by the year 2030. Cedric Philibert, senior analyst in the renewable energy division at the IEA said: "Photovoltaic and solar-thermal plants may meet most of the world's demand for electricity by 2060 – and half of all energy needs with wind, hydropower and biomass plants supplying much of the remaining generation...Photovoltaic and concentrated solar power together can become the major source of electricity."



<b>Selected renewable energy global indicators</b>	<b>2008</b>	<b>2009</b>	<b>2010</b>	<b>2011</b>	<b>2012</b>	<b>2013</b>
Investment in new renewable capacity (annual) (10 <sup>9</sup> USD)	130	160	211	257	244	214
Renewables power capacity (existing) (GWe)	1,140	1,230	1,320	1,360	1,470	1,560
Hydropower capacity (existing) (GWe)	885	915	945	970	990	1,000
Wind power capacity (existing) (GWe)	121	159	198	238	283	318
Solar PV capacity (grid-connected) (GWe)	16	23	40	70	100	139
Solar hot water capacity (existing) (GWth)	130	160	185	232	255	326
Ethanol production (annual) (10 <sup>9</sup> litres)	67	76	86	86	83	87
Biodiesel production (annual) (10 <sup>9</sup> litres)	12	17.8	18.5	21.4	22.5	26
Countries with policy targets for renewable energy use	79	89	98	118	138	144

**Figure 8:** Renewable energy global indicators from 2008 until 2013.

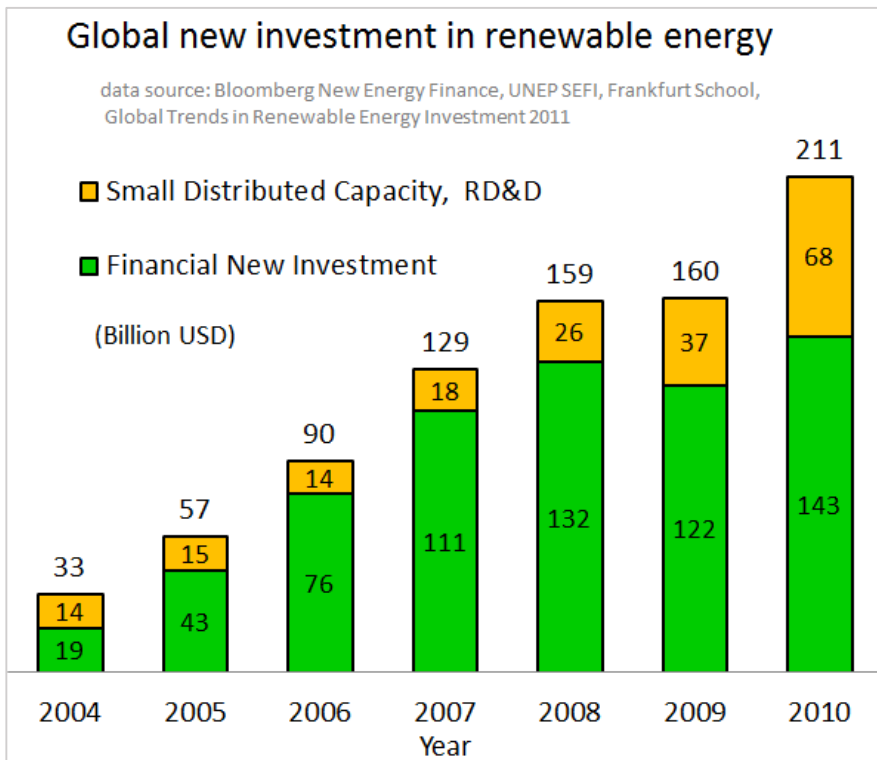

**Figure 9:** Global new investment in renewable energy in 2011.

### 3. RESULTS

#### The impact of renewable energy on rural development

The primary obstacle that is preventing the large scale implementation of solar powered energy generation is the inefficiency of current solar technology. Currently, photovoltaic (PV) panels only have the ability to convert around 16% of the sunlight that hits them into electricity. At this rate, many experts believe that solar energy is not efficient enough to be economically sustainable given the cost to produce the panels themselves.

The paper suggests that RE deployment can increase and stabilize rural incomes, contribute to the development of new products, new technologies and new policy approaches, improving the overall innovation capacity in rural areas, empower local communities, and finally, provide remote rural communities with cheaper sources of energy. These are discussed further below.

### 4. CONCLUSION

Policies to ensure that renewable energy deployment benefits rural areas include:

- Avoiding applying generic national criteria that ignore the suitability of local conditions and the opportunities for integrating RE into local productive fabric, supporting RE deployment where capacity is low results in high cost and limited energy.
- Limiting subsidies in scope and duration and using them only to induce RE projects that are close to being viable in the market. In general, RE is more expensive in the market than conventional energy, but there are regions where the cost disadvantage of certain renewables is relatively small, or non-existent. In these regions, where conventional energy is relatively expensive, it is much easier for RE to be competitive.

- Limiting subsidies in value: if subsidies are too high, they tend to encourage RE projects that are designed to capture the maximum amount of subsidy. This sort of rent-seeking behavior can lead to high cost energy that is only viable as long as high levels of subsidy are sustained, and can also intensify competition for natural resources.

**Figures 10-12** illustrate some of the global developments in renewable energy developments including consumption patterns, capacities and energy potentials.

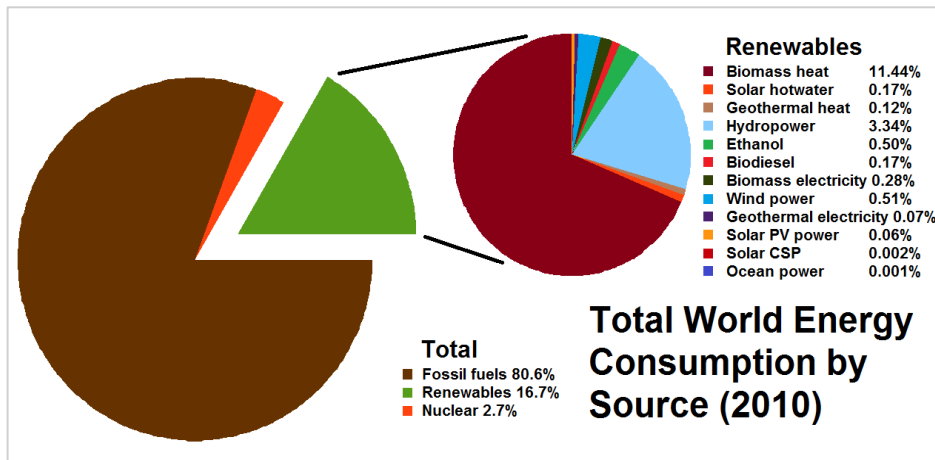

**Figure 10:** Total world energy consumption by source in 2010.

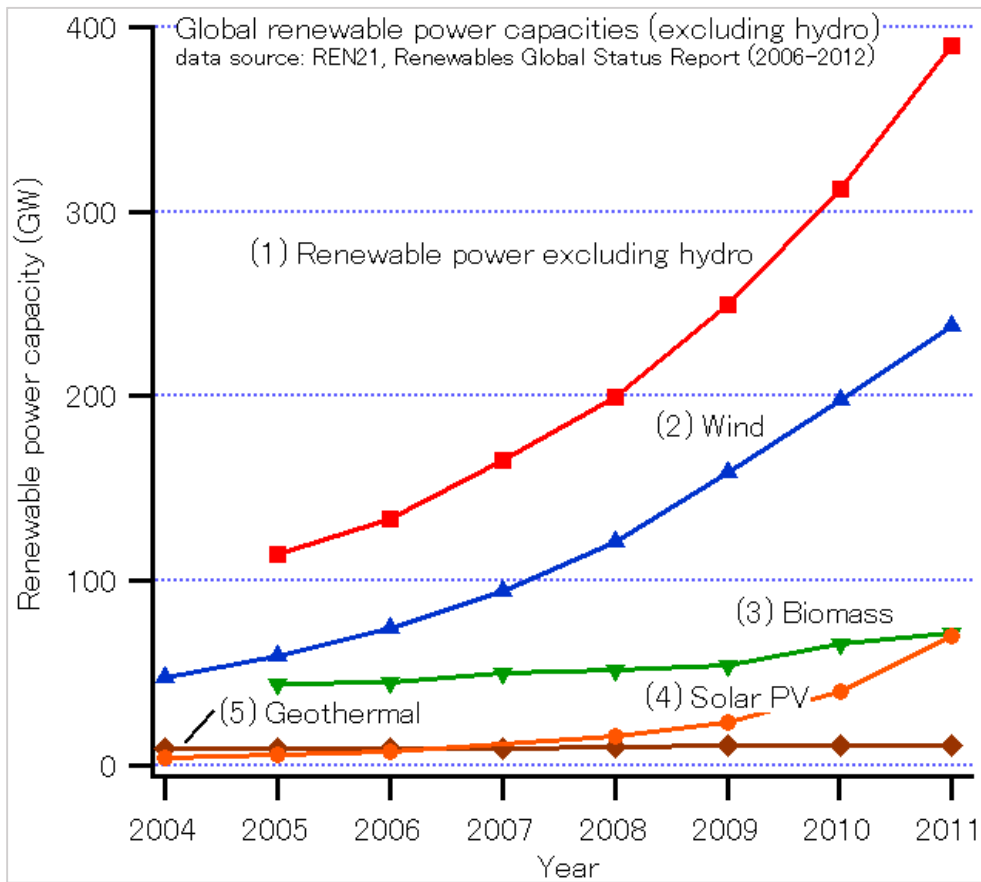

Figure 11: Renewable power capacity in GW from 2004 until 2011.

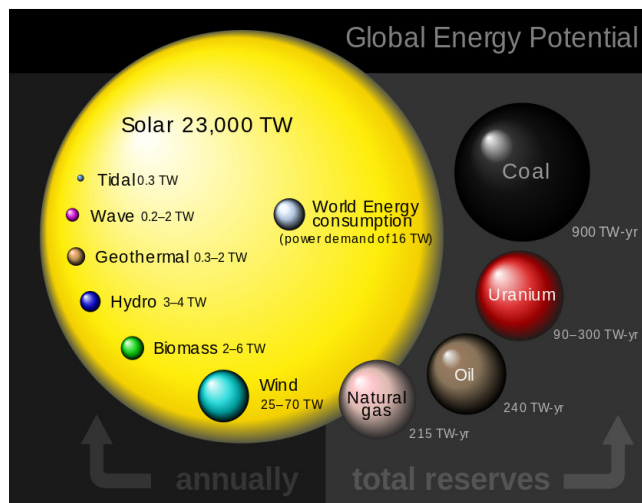

Figure 12: Global energy potential in TWs.

## REFERENCES

**Boix R. and Vaillant, Y., 2010:** Industrial Districts in Rural Areas of Italy and Spain, *Sviluppo Locale*, 14(35), 73-114.

**International Energy Agency (IEA), 2011:** *Deploying Renewables 2011: Best and Future Policy Practice*. IEA, Paris.

**Kammen, D. M, Kapadia, K., and Fripp, M., 2004:** *Putting Renewables to Work: How Many Jobs Can the Clean Energy Industry Generate?* RAEL Report, University of California, Berkeley.

**Organisation for Economic Co-operation and Development (OECD), 2011:** *Regional Outlook 2011*. OECD, Paris.

**Selfa, T., Kulcsar, L., Bain, C., Goe, R., and Middendorf, G. 2010:** Biofuels Bonanza? Exploring Community Perceptions of the Promises and Perils of Biofuels Production, *Biomass and Bioenergy*, 35(4), 1379–1389.

**United Nations Environment Programme (UNEP), 2011:** *Global Trends in Renewable Energy Investment 2011*. UNEP, Nairobi.

# The Concept of a Combined Water and Electric Microgrid for Rural Communities

James L. Persson, MD MPH ([james.persson@hotmail.com](mailto:james.persson@hotmail.com)) & Dean L. Muirhead, PhD ([dean@vesselsworld.org](mailto:dean@vesselsworld.org)),  
Vessels World, Suite 1, 2517 NASA Parkway, Seabrook, Texas, USA 77586-3486, [www.vesselsworld.org](http://www.vesselsworld.org), 281-217-2820

## 1. BACKGROUND

Rural communities relying on a shared public water source require household occupants to collect water each day - a significant burden limiting social and economic opportunities in communities.<sup>1</sup> Each day, the household water collector, typically a women or girl, may spend up to 240 Calories (279 watt-hours) of energy fetching water, consuming up to 12% of their daytime food energy.<sup>2</sup> Furthermore, the amount of water collected from a public source (roughly 20 liters per person per day for a source located between 100 and 1000 meters away from household) is not expected to meet all hygiene needs and almost invariably becomes contaminated in household storage.<sup>3</sup>

In contrast to shared public sources, piped household water access is associated with adequate amounts of water for hygiene and frees up collection time and energy for other activities.<sup>1</sup> To reach this goal, communities often model their water networks after piped distribution systems in developed countries, resulting in oversized, leaky, and maintenance-intensive buried water networks prone to failure. Once in place, the lack of human and financial resources has been a key barrier to the financial sustainability of services.<sup>1,4</sup> Service interruptions in these underground systems are not only inconvenient, they cause a significant public health hazard due to backflow of contaminated water into the buried pipes.<sup>1</sup> Given the unpredictable service, expensive connection fees, varying quality of water and the availability of alternate water sources, poor households often miss out on the health, economic and social benefits of piped water access.<sup>4</sup>

As a separate household utility, electricity creates an immediate and noticeable improvement in quality of life and allows diversification of activities. Since electricity has no other suitable alternative source for lighting or communication technologies, poor households will typically connect to an electric grid if available.<sup>5</sup> Access to electricity for lighting also replaces costly alternatives such as kerosene lamps. Unlike water distribution systems being placed underground, electric distribution systems can be built and operated in either underground or overhead locations. With roughly 18% of electric distribution networks in the U.S. being underground,<sup>6</sup> the advantages and disadvantages of each type of system are well known. Underground electric utilities face many of the same problems as buried water systems (greater costs to install, risk of water intrusion, greater need for redundancy in design, and advanced skill sets to operate and maintain). Meanwhile, overhead electric networks cost 5-10 times less, last longer (50 years versus 30 years for underground systems) and require less skill to operate and maintain.<sup>6</sup> The electric sector's experience with overhead utilities may offer guidance for providing household water to communities in a cost-effective manner.

## 2. CONCEPT

The combined microgrid is a unique method of providing basic household piped water and modern energy access to remote rural communities. In this system, a rudimentary network of small suspended “water mains” is combined with an overhead electrical distribution system to form a combined water and electrical microgrid. Water flows in tubing alongside the suspended electrical wires and is delivered to households using the same relatively simple and low maintenance infrastructure as electricity. The primary goal of the microgrid is to provide the health, economic and social benefits of piped household water access while avoiding the high initial and recurring costs of buried water main systems.

The combined microgrid system consists of a network of utility poles and suspended wire centered on an established shared water supply in rural communities. An array of solar panels is located at the water source and serves as the power source for the combined system. Suspended wires from the solar power supply radiate out along the utility pole system to reach the individual households. UV-resistant plastic tubing (no greater than 4 cm in diameter) and electric conductors are suspended from a common guidewire and reach each households within a one kilometer radius from water source (Figure 1). Water from the improved water source is pumped into the overhead distribution system and delivered at a constant pressure throughout the entire day to the network. Electricity from the solar panel array is stored in a battery bank or fuel cell located near the water source and delivered as low-voltage (e.g. 120 or 240 volts) later in the evening.

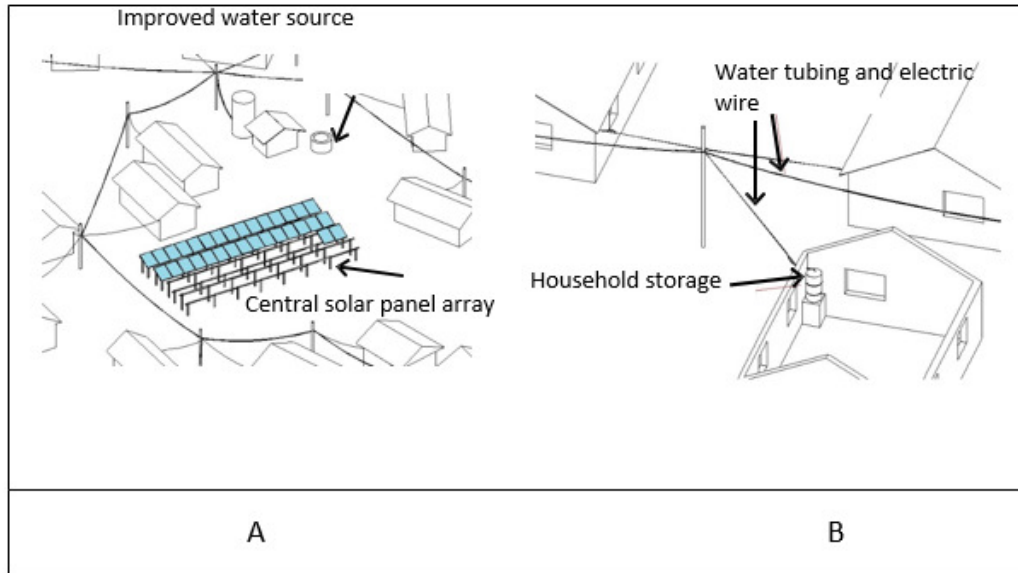
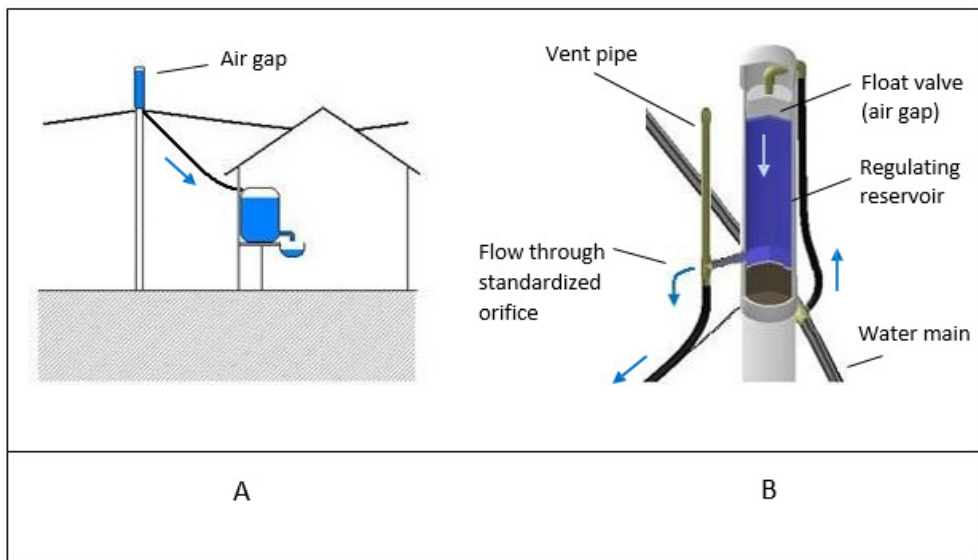

**Figure 1:** Views of central solar panel array collocated with improved water source (A) and household connection with subsequent storage (B).

### Stable Water Service

The efficient operation of a combined microgrid is feasible when delivering water *only* for domestic health requirements. Per domestic service level guidance, 50 liters per person per day (lppd) assures all personal and food hygiene needs are met while addressing laundry and bathing needs.<sup>3</sup> This relatively small amount can be delivered practically with narrow tubing and acceptable pressure losses if flowing at a constant rate throughout the day. In developed nations, large mains are needed to supply fluctuating household demands and potential fire-fighting demands. In contrast, the microgrid delivers only the health-based amount evenly through the entire day. This low and continuous flow allows the mains to be small and suspended with the electrical wire – a key requirement for the system.

Upon reaching a utility pole located near a dwelling, the microgrid relies on gravity to deliver water safely to household storage. A conventional service connection to a buried water network requires an uninterrupted connection between the water main and household plumbing system to pressurize household plumbing. If pressure is not maintained, contaminated water may flow back into water main through the service connections during pressure drops. The microgrid addresses this issue by elevating the service connection and turning it upside down. Rather than water main pressure actively raising the water up to the tap, the embedded potential energy in the elevated system allows water to flow passively down to the water storage. Subsequent peak water flow requirements are met with the water level in the household storage tank rather than the pressure in the preceding water network. Due to the water network elevation and the incorporation of air gaps at the service connection, backflow of water into the elevated water main is impossible.



**Figure 2:** Schematic (A) and cut-away view (B) of service connection to water main. Air gap breaks the “pressure connection” to water main, preventing back- flow into system. Blue arrows show flow from main to household storage.



### **Scalable Electricity service**

At start-up, the microgrid would provide roughly 1 watt of power for 4 hours daily to a dimmable white LED in each household, producing an amount of light (6 lux) comparable to a typical kerosene lantern (Figure 3). The progression of lighting illustrated in Figure 3 would be representative of watt-by-watt monthly increases in household power, such as adding a 200-watt panel to a microgrid serving 200 dwellings. After 7 months, the LED receives 7 watts of power and provides over 300 lux of light (the Western standard for reading).

Kerosene lamp baseline comparison (6 lux):



Microgrid progression of lighting using dimmable white 7-watt LED with reflector:



**Figure 3:** Visible watt-by-watt progression of household lighting in microgrid.

The regular addition of large wattage solar panels to the village grid results in a steady watt-by-watt increase in household power as opposed to panel-by-panel lumpy purchases of smaller wattage solar panels by households with disconnected solar systems. The rate of the progression would depend on the amount of resources the community would be willing to devote to expansion of grid. To speed up progression, the common grid provides an opportunity for connected households to establish their own solar systems and sell energy to the community grid. Start-up renewable energy micro-enterprises within the community not only help individual households generate income, they also provide a community-wide benefit by speeding up the progression of the grid and the variety of appliances.

### 3. BUSINESS MODEL

The microgrid maximizes initial capital investment by using the same utility pole network to provide both services. Although utility poles are typically associated with distribution of electricity, the small amount of electrical energy initially delivered to households (0.004 kWh per household daily) would not generate enough revenue to financially sustain a stand-alone electric grid, let alone allow expansion. A household of five members would pay only \$0.01 USD per month for this amount of electricity. Instead, combined microgrid tariffs are based on the accompanying household water service (\$0.50 USD per cubic meter). With delivery of 50 lppd, the same household would pay \$3.50 USD per month for piped water access.

The difference between water tariff revenue and the microgrid's actual operating cost is used to increase the microgrid power generating capacity. The easily maintained and monitored elevated microgrid significantly reduces leakage and nonrevenue water loss which can otherwise amount to 60% of distributed water in buried systems.<sup>4</sup> With energy representing up to half the operating cost for water utilities,<sup>4</sup> the increased efficiency and use of solar energy for pumping water further lowers operating cost. With water loss, energy, labor and equipment costs minimized compared to a standard buried water system, savings are reinvested into the electric system by regularly adding solar panels to the central array.

Despite the valuable service provided, water utilities often suffer financially from uncollected water tariffs and customers' lack of willingness to continually pay tariffs. Instead of relying on consumers to make regular payments for a *stable* amount of water service, the microgrid utilizes the *scalable* increases in electricity to incentivize payment of water bill. Figure 4 shows an example of household progression of electricity and variety of appliances, starting with the advancement of lighting shown previously in Figure 3. In this model, the initial under-capacity of the electrical grid (6 lux of lighting) is intentional, serving as a starting point for the immediately noticeable and continuous addition of electric power.

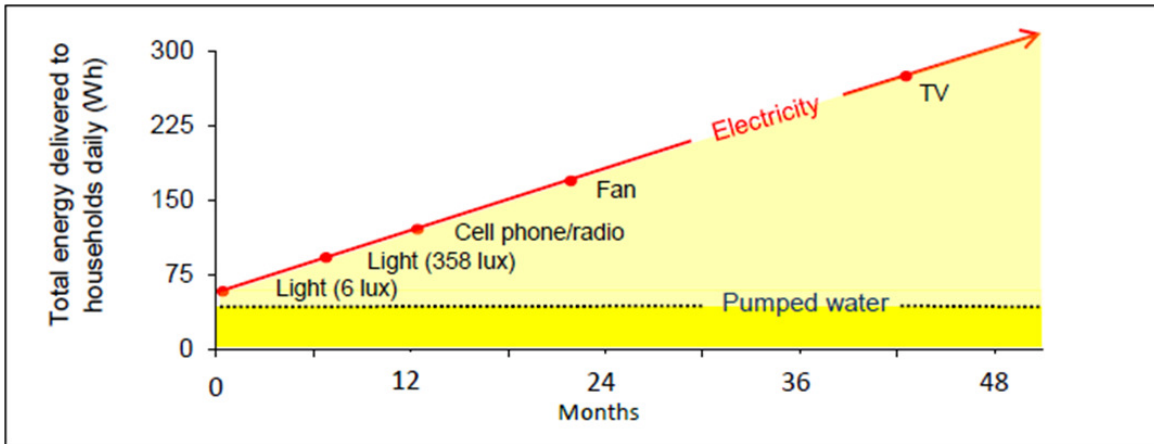

**Figure 4:** Example of total energy delivered to household as combination of embedded energy in pumped water (dotted line, stable at 50 Wh) and electricity (solid line, starting at 4 Wh and increasing indefinitely).

The increase in lighting from 6 to 358 lux (Figures 3 and 4) is apparent to occupants and occurs when willingness to pay tariffs otherwise wanes in a typical water system. During the first 7 months of operation, the percent of households paying tariffs may drop to 50% in a stand-alone water system. Instead, electric power has visibly increased 600% in the combined microgrid (1 watt to 7 watts). Rather than being a static distribution system that only delivers water, the steady advancement of electricity provides positive reinforcement for paying water tariffs, helping foster the financial sustainability of piped water access.

#### 4. SUMMARY

The combined microgrid distributes renewable energy to households through parallel water and electric networks using the same above ground infrastructure, saving both capital and operating costs. The health benefits of household piped access are established in medical literature and provide a health-based justification for an initial grid reaching each household. Once established, the bundled infrastructure is owned, operated, maintained and financed by the local community. The indefinite expansion of the scalable electric component helps provide the motivation to financially sustain the combined grid while solidifying a foundation for diffusion of future innovations in renewable energy and energy-efficient appliances.

#### REFERENCES

**Thompson, J., Porras, I., Katui-Katua, M., Mujwahuzi, M., Tumwine, J., Johnstone N, and Wood, L., 2001:** *Drawers of Water II: Thirty Years of Change in Domestic Water Use and Environmental Health in East Africa*. International Institute for Environment and Development.

**White, G., Bradley, D., and White, A., 1972:** *Drawers of Water: Domestic Water Use in East Africa*. University of Chicago Press, Chicago.

**Howard, G. and Bartram, J., 2003:** *Domestic Water Quantity, Service Level and Health*. Geneva. World Health Organization Press, Geneva.

**Komives, K., Foster, V., Halpern, J., and Wodon, Q., 2005:** *Water, Electricity and the Poor - Who Benefits from Utility Subsidies*. The World Bank, Washington DC.

**Barnes, D., Krutilla, K., and Hyde, W., 2005:** *The Urban Household Energy Transition - Social and Environmental Impacts in the Developing World*. Resources for the Future Press, Washington DC.

**Hall, K., 2009:** *Out of Sight, Out of Mind Revisited - An Updated Study on the Undergrounding of Power Lines*. Edison Electric Institute, Washington.

**Feachem, R., Burns, E., Curtis, D., Cairncross, S., Khan, K., Cronin, A., Lamb, D., Cross, P., and Sonthall, H., 1978:** *Water, Health and Development – An Interdisciplinary Evaluation*. TriMed; 19, London.

# **General Characteristics of Mechanical Wind Water pumping System and the Possibility of Applying System in Egypt**

Mohamed Ramadan Mohamed<sup>a</sup>

<sup>a</sup>Architect, registered in M.Sc program of environmental design in department of architecture, Cairo University, Giza, Egypt

6Kamel Shinawi St, Giza, Egypt-Tel: 01001970079-E-mail: Archmohamed90@gmail.com

## **Abstract**

Egypt already suffers from water stress due to a steady increase in population, inefficient water use and climate change impacts. This is despite that fact that the country possesses a high groundwater potential, available from different aquifers that cover a large area of Egypt. However, the absence of infrastructure in rural areas, including water networks and electricity grids, doubles the pressure on these parts of the country and leads rural populations to use fuel-powered pumps for drinking or irrigation. These fuel-powered pumps pollute the environment and accelerate climate change. Meanwhile, Egypt has high wind potential and is considered one of the countries with the best wind resources in world. Wind energy for water pumping is an independent infinite energy resource; it has low running costs and reduces the contribution of greenhouse gases (GHG) to global warming. Perfect meteorological conditions and underground water are available in remote areas, where mechanical wind water pumping system could supply freshwater for drinking, irrigation or industrial production in residential, agricultural and industrial activities. This paper defines limitations such as water stress and energy shortages, discusses mechanical wind water pumping systems, and recommends appropriate sites to install such wind systems for water pumping in Egypt.

## **1. INTRODUCTION**

Egypt is the largest oil and natural gas consumer in Africa in 2013. Egypt's primary energy consumption from non-renewable accounts for 96% of the country's total energy consumption in 2013. The remaining 4% of energy consumption are provided by renewable energy – 3% from hydroelectricity generated at the Aswan High Dam, and 1% from solar and wind energy (EIA, 2015). In the early 1980s, Egypt integrated a renewable energy strategy into its national energy plan. The strategy targeted to supply 5% of the country's total energy consumption with renewable energy by the year 2005. Unfortunately, Egypt achieved only 4% by 2013 (Moussa, 2000).

The world already suffers from water shortage due to an increased incidence of drought as a result of climate change. 2.8 billion people around the world suffer from water scarcity at least once month out of every year. Moreover, around 1.2 billion people, nearly 20% of the world's population, lack access to clean drinking water (UNDP, 2006). Egypt has been suffering from water scarcity since the 1990s. A total of 97% of water supply in Egypt depends on the Nile, the rest is obtained from winter rain and groundwater aquifers. The gap between the needs and availability of water is about 20 BCM/year. Approximately 97% of the country's urban population and 70% of rural population of Egypt relies on piped water supply. Surface water

supplies represent about 83% of the total municipal water demand, and about 17% come from groundwater (MWRI, 2014), which means that about 14 million people are dependent on groundwater as a source of drinking water.

Egypt's water resources are vulnerable due to water stress and climate change, a rapidly increasing gap between water supply and demand due to an increase in population and droughts. Climate change will lower Egypt's annual capital share of water from 700 m<sup>3</sup> to 350 m<sup>3</sup> by 2040. Due to an expected decrease in Nile discharge (Zubricki et al., 2011), in the future, reliance on groundwater will increase to compensate for shortage of surface water supplies. The significant depth of groundwater resources in Egypt will mean that more pumps will be required for accessing water, which would translate into a greater consumption of energy (IPCC, 2001).

The objective of the present work is discussing mechanical wind water pumping systems and their applicability in Egypt, and select appropriate sites in Egypt for such a system by analyzing opportunities and challenges of applying mechanical wind water pumping in Egypt. Furthermore, this paper aims to raise awareness among stakeholders by generating a greater understanding of the problem and assessing how the system can contribute to solving rural water and energy problems. This paper will define the problems such as water stress, energy shortages and climate change, discuss a possible solution using clean and renewable energy for water pumping in rural areas, and evaluate the options according to a set of criteria, including suitability to available technologies in Egypt. Aquifer depth and wind speed represent the criteria of research for evaluating the ability of mechanical wind water pumping system to act as an adaptation to water stress, energy shortages and climate change.

## **2. GROUNDWATER AND WIND RESOURCES IN EGYPT**

Egypt has a high wind potential and is considered one of the countries with the best wind resources in the world. Several areas are particularly favorable for wind energy: the Gulf of Suez, where wind speeds reach 7-12 m/s, the Nile river banks, where the average wind speed reaches 7.5 m/s, the Gulf of Aqaba and areas along the North Coast, where wind speeds reach 6-8 m/s, and the Eastern and Western Deserts, where, for example in areas close to Kharga oasis, wind speeds up to 6-7 m/s (Salah, 2015). Wind power generated from the Zafarana and Hurghada wind farms in 2014 were estimated to generate 1.7% of the country's electricity capacity. Egypt plans to increase its wind generation to 7.2 GW by 2020, representing 12% of the generated electricity capacity expected in 2020 (Nachmany, 2015). The wind resource map (Figure 1) provides an overview of the climatological wind conditions across Egypt and can be used to estimate the long-term wind conditions at large-scale grid points. The distance between these grid points is 7.5 km, but the accuracy in the resource estimates for any specific site is limited because it does not take all the small-scale features of the terrain into account; the error percentage is about 10% for large scale assumptions (Mortensen, 2006).

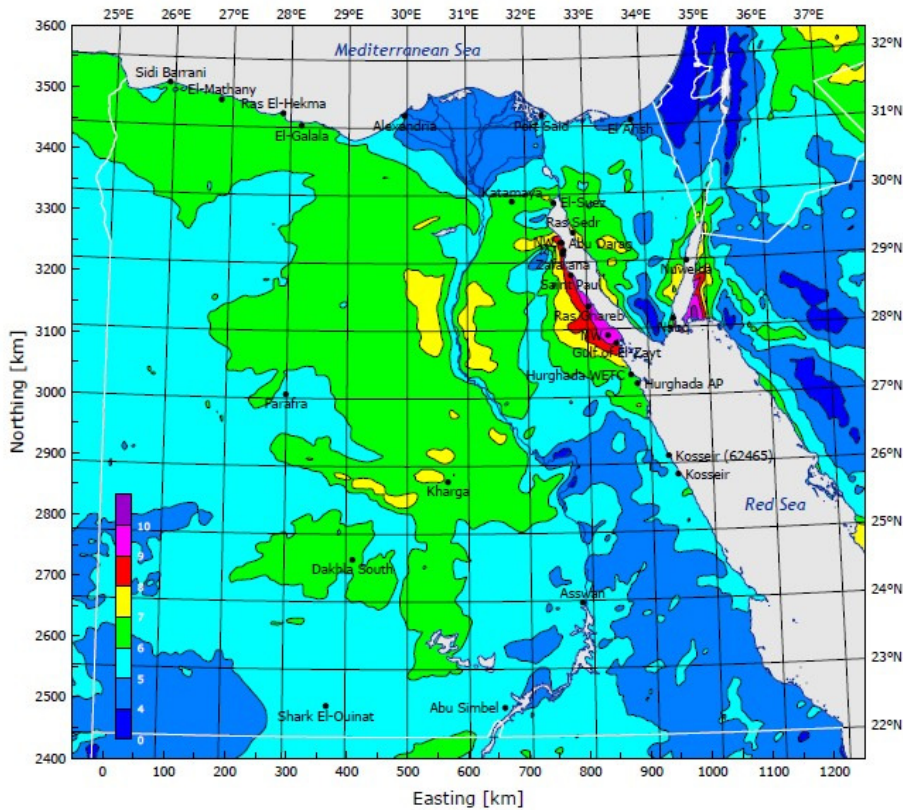

**Figure 1:** Wind Resource Map of Egypt (New and Renewable Energy Authority).

Egypt has six groundwater aquifers that can be divided into renewable and non-renewable aquifers. These aquifers contain water at different depths, and the current total consumption from Egypt's aquifers was estimated at 6.5 BCM in 2013. This quantity, according to the official website of Egypt's State Information System SIS (2015), can be increased in the future to reach 7.5 billion cubic meters/year without exposing the underground water to risk. The Nile Valley and Delta aquifer's yield does not exceed 4 billion m<sup>3</sup>/year and the digging depth ranges from 0 to 100 m. The coastal aquifer's yield does not exceed 2 billion m<sup>3</sup> /year and the digging depth is less than 2 m in Sinai. The Nubian Sandstone aquifer covers a large area and consists of shale and sandstone layers. Its yield exceeds 100 billion m<sup>3</sup>/year and the digging depth ranges from 0 m to 500 m. The Moghra aquifer's yield exceeds 1 billion m<sup>3</sup>/year and the digging depth ranges from 0 to 200 m. The Fissured Carbonate aquifer is one of the poorest aquifers in Egypt consists of shale and sandstone layers (Salim, 2011). The fissured and weathered hard rock aquifer system, predominates in the Eastern Desert and Sinai (Elbeih, 2014) (Figure 2).

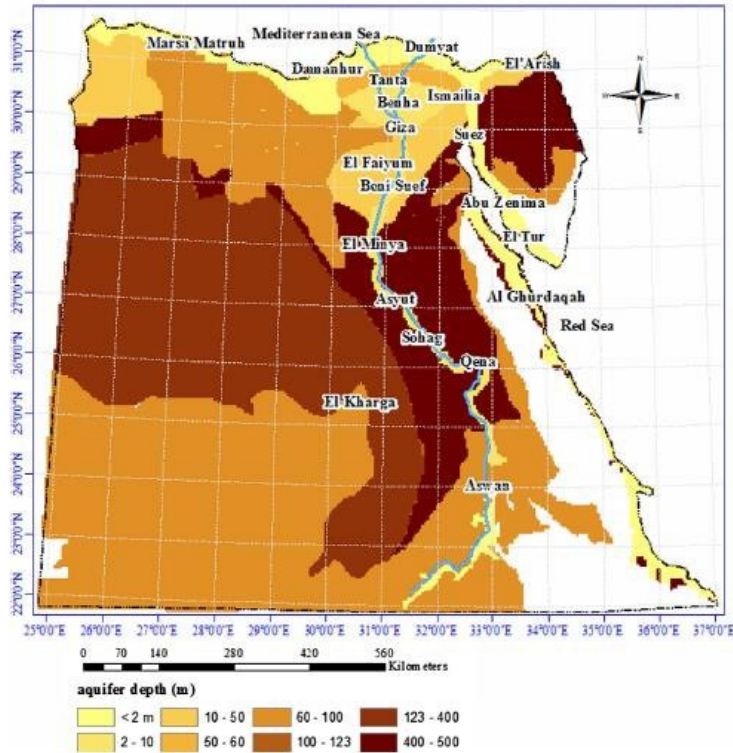

**Figure 2:** Classification of Aquifer Depth in Egypt (Salim, 2011).

### 3. MECHANICAL WIND PUMPING SYSTEM

#### 2.1. System History

A windmill is one of the oldest methods of generating energy. It was used to grind grain or draw up water in Persia then spread in Europe. The first application harnessing the energy of wind to pump water was invented in 1854 by Daniel Halladay in United States. By 1930, millions of American wind pumps had been produced and installed around the world (Shepherd, 1990). Since that time, modifications have improved the mechanical wind pump technology to become lighter, less expensive and more efficient than in the past (Salomonsson and Thoresson, 2010).

#### 2.2. Basic Components of the System

Mechanical wind water pumping systems consist of a rotor that converts wind energy into rotary motion. The rotor's diameter is about 2-6 m with 15 to 40 steel or galvanized blades, a gearbox mechanism driven by the blades that converts the rotary motion of the fan into reciprocating motion, and a sucker that descends from the windmill to the well to transfer power to the underground pump and pump that with each motion of the sucker rod, draws water upwards through a one-way check valve (Enciso and Mecke, 2015) (Figure 3).

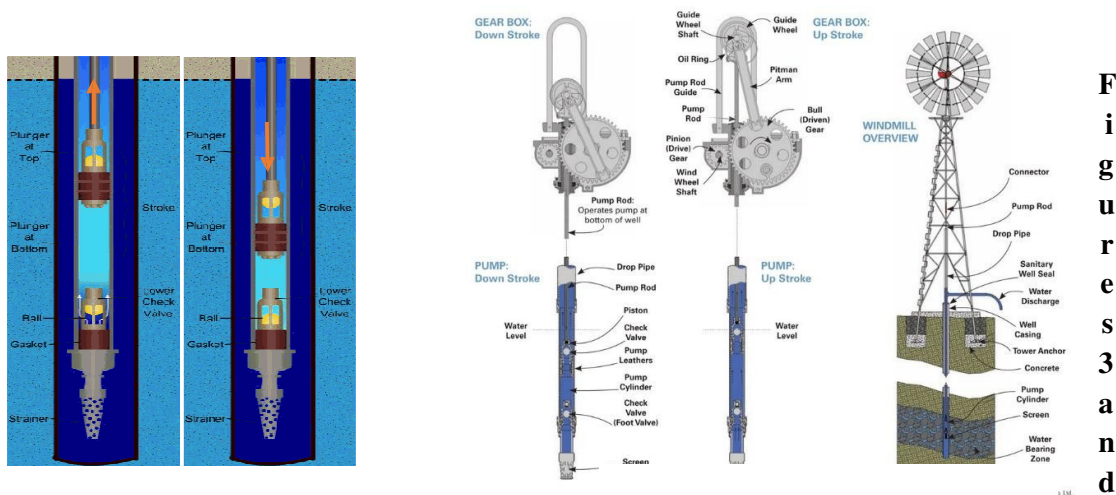

F i g u r e s 3 a n d F

**figure 4:** Mechanism of Windmill Piston (left) ([www.villageelders.com](http://www.villageelders.com)) and Components of the System (right) (Windmill C, 1977).

Some systems contain tail guides that orient the turbine into the wind when the wind changes direction, and swing the turbine to face and collect wind energy, which improves the system’s efficiency (Probst, 2011).

**2.3. System Mechanism**

When the wind blows with a minimum velocity of about 2.5-3 m/s, it spins the blades around a shaft, the shaft drives a geared mechanism that converts rotary motion to an up-and-down motion, the motion drives a long sucker rod and generates the force required to lift the piston and the water it contains – the pumping process begins (Salomonsson and Thoresson, 2010). Each up-stroke pulls a certain amount of water into the pump cylinder, because when the piston is pulled upwards, water enters the pipe through one of the valves because of the low pressure that has arisen in the pipe. When the piston is then pushed down, the water is forced out through the second valve because the first valve is closed (Figure 3) (Ironwindmill, 2015).

**2.4. System Capacity**

The amount of water a windmill can pump is regulated by the size of the pump cylinder, the elevation of pumping, the wind wheel size and the wind speed on site. A typical windmill with a 1.75 inch cylinder diameter and an 8 feet diameter wheel can lift water 185 feet and pump about 150 gallons an hour in 15 to 20 mph winds. The bigger wind wheel can lift water higher than a smaller one, and a larger cylinder pump can deliver a greater volume of water. Thus, if the size of the pump cylinder is increased to 3 inches while still using the same 8 feet diameter wheel, the volume delivered increases to 470 gallons per hour, but the maximum lift decreases to 68 feet. If we stay with that 3-inch cylinder but increase the windmill to a 16-foot diameter wheel, the system will be able to deliver the same 470 gallons, lifting the water a total of 360 feet. At 15 to 20 mph wind speeds the short stroke reduces capacity by 25% and increases elevations by 33% (Table 1) (Moore, 2008).



**Table 1:** Pumping Capacities of Water Pump Windmill (Enciso and Mecke, 2015)

Table 3. Pumping capacities as influenced by the diameter of the cylinder and blade diameter of the windmill.

Cylinder diameter (inches)	Pumping capacity (gallons per hour)		Blade diameter (feet)					
	Wheel diameter (feet)		6	8	10	12	14	16
	6	8 to 16						
Pumping elevation (feet)								
2	130	190	95	140	215	320	460	750
2 1/2	225	325	65	94	140	210	300	490
3	320	470	47	68	100	155	220	360
3 1/2	440	640	35	50	76	115	160	265
4	570	830	27	39	58	86	125	200
4 3/4	—	1,170	—	—	41	61	88	140
5	900	1,300	17	25	37	55	80	130
6	—	1,875	—	17	25	38	55	85
8	—	3,300	—	—	14	22	31	50

## 2.5. Specific Site of System

The primary consideration in choosing a site for a windmill is whether there is sufficient wind. Thus, obtaining site-specific measurements of wind speed, duration and directions covering various times specifically during the expected water pumping period over the year to is necessary in order to determine whether a wind-powered pumping unit will be a suitable option (Al-Bahadly, 2011). An analysis of existing meteorological data of wind measurements on long and short term bases are necessary, but the final decision depend on site measurements because topographic such as ridges, buildings and vegetation affect the wind speed (Omer, no date). This is done through taking measurements by installing an anemometer with an automated data recording device above portable towers similar in height to the proposed windmill, to ensure that the windmill receives a free flow of air from all directions. The rotor of a windmill should be located at least 5 to 6 m (15 to 20 feet) higher than any obstruction within a radius of about 130 to 180 m (450 to 600 ft.) of the windmill's site (Figure 5) (Agriculture and Agri-Food Canada, 2015).

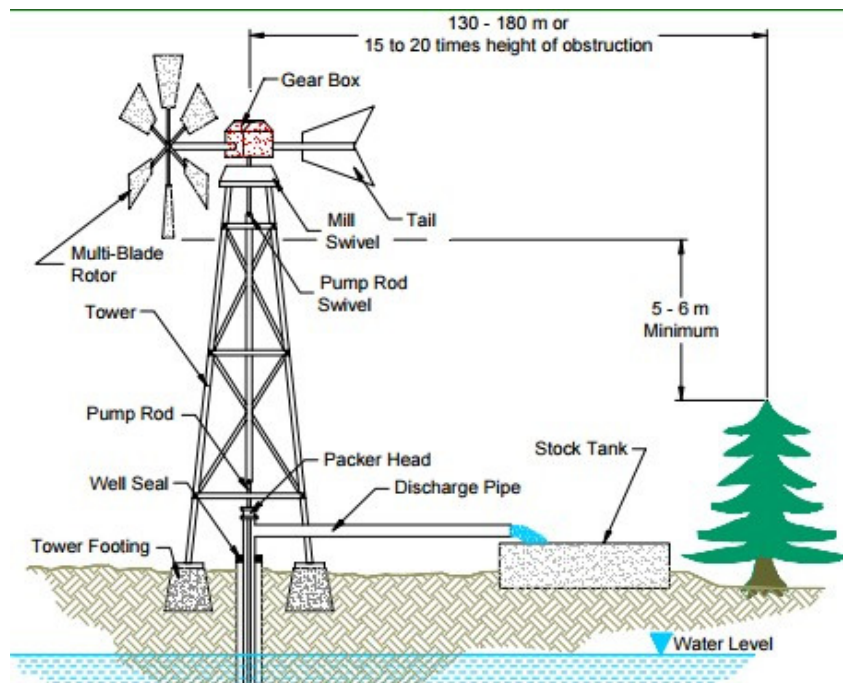

**Figure 5:** Distance between the Windmill and Obstructions on Site (Agriculture and Agri-Food Canada, 2015).

## 2.6 System Maintenance

Minimal maintenance is required for the system, only greasing of all bearings, checking for any loose bolts or nuts twice a year, checking the rubber diaphragms around the valves annually, and checking the anchoring system for the windmill tower to ensure that the windmill is not toppled during high winds. When water contains a high proportion of deposits, maintenance times of pump, rods and delivery pipes must be increased because deposits will cause blockage in the pump parts (Water Pumping Windmills, 2010).

## 2.7 Advantages and Disadvantages of the System

### 2.7.1. Advantages

- The system is a renewable and clean energy source, is non-polluting and has no adverse effects on the environment.
- It is economically competitive and suitable for rural areas that lack energy sources (Mwangi, 2012).
- Lower initial and running cost and simpler installation and maintenance (it takes only one to two days to install or replace an existing windmill water pump)
- Installation and replacement can be carried out by a local company (Table 2) (Stuck, 2015).

### 2.7.2. Disadvantages

- In some areas, wind power is not consistently available and wind speeds fluctuate across the seasons of the year.
- Destructive winds can ruin the system, but there are some types that contain breaks and a moveable tail that can be placed parallel to the blades in destructive winds manually (Trunz, 2010).
- The overall weight of a wind power system is relatively high, large areas are required for installation of wind energy systems and it does not meet the water needs of large cities and industry (Mwangi, 2012).

**Table 2:** Comparison between Mechanical, Electric and Solar Pumping Systems (Source: Author).

		Mechanical Wind Water pumping System	Electric Wind Water pumping System	Solar systems
<b>Weather condition</b>		Gentle breeze or above	Moderate breeze or above	sunny
<b>Size of system</b>	Blade diameter	6-16m	9-124 m	-
	Tower height	10m	24-114	-
		-	-	4m <sup>2</sup> -12 m <sup>2</sup>
<b>Minimum Wind speed</b>		2.5-6 m/s	6-10 m/s	-
<b>Install</b>		Hard	Hard	Easy
<b>Cost</b>		Lower initial cost	Higher initial cost	Higher initial cost
<b>Maintenance</b>		Simple but more maintenance times	Complicated but less maintenance times	Simple and Low maintenance
<b>Availability of spare parts</b>		easy to find	difficult to find	difficult to find
<b>Lifetime</b>		50	20 years	20 years Batteries 5 years
<b>Energy storage</b>		Not included	Batteries included	Batteries included

## 4. THE POSSIBILITY OF APPLYING THE SYSTEM IN EGYPT

In this study, land use in Egypt is classified in terms of availability of aquifer reservoirs, and the compatibility of aquifer depths with the pumping elevation of mechanical wind water pumping systems is assessed. Aquifer depth and wind speed represent the criteria for selecting areas compatible with mechanical wind water pumping systems. Most water pumping windmills start pumping water at wind speeds between 4-6 m/s, reach their best efficiency at wind speeds of 6-10 m/s, and can lift water from depths up to 360 meters. By overlaying the map of aquifer depths and the wind atlas of Egypt and selecting areas compatible in terms of both aquifer depth and wind speed, the criteria for evaluating the ability of mechanical wind water pumping system area applied.

The map shown in Figure 6 presents the results of evaluating green areas representing the best locations to install water pumping windmills due to wind speeds between 6-10 m/s and water depths between 0-400 m, making the system work with high efficiency. The cyan areas represent the second choice of locations for installing the system due to wind speeds between 4-6 m/s and water depths between 0-400, making the system work with low or medium efficiency. Red areas represent rejected areas due to depths of water that exceed 360 m. Light yellow or orange represent rejected areas due to water depth and low productivity of aquifer reservoirs, and dark grey represents rejected areas due to insufficient wind speed.

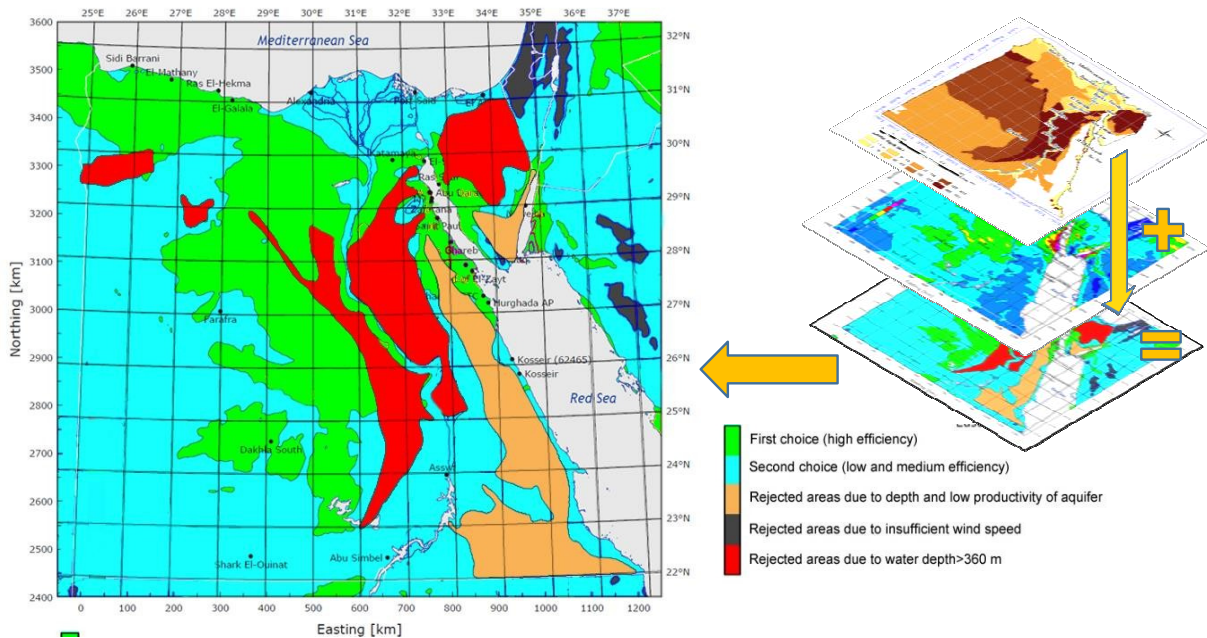

**Figure 6:** A priority of suitable areas for mechanical wind water pumping system in Egypt.  
Source: Author

## 5. CONCLUSION

Egypt has valuable wind and groundwater resources. Most of Egypt's wind speeds range between 4-10 m/s and most of aquifer depths range between 0-400 m as shown in Figure 6. All of these factors are compatible with the requirements of the mechanical wind water pumping system, which is a sustainable solution that depends on renewable energy for rural populations with no access to centralized power and water supply. Using water pumping windmills in water pumping and irrigation systems will decrease the poverty rate and increase the rate of development through providing fresh water for drinking, irrigation, or industrial production in residential, agricultural and industrial areas of remote or rural locations.

## REFERENCES

- Agriculture and Agri-Food Canada, 2015:** *Wind-Powered Water Pumping Systems for Livestock Watering: Fact Sheet*. Accessed from <http://goo.gl/WxUIYu.pdf> (25 August 2015).
- Egypt State Information Service (SIS):** Accessed from <http://www.sis.gov.eg/en/> (24 August 2015).
- Elbeih, S.F., 2014:** An Overview of Integrated Remote Sensing and GIS for Groundwater Mapping in Egypt, *Ain Shams Engineering Journal*, 6(1), 1-15.
- Enciso, J. and Mecke, M., 2015:** *Using Renewable Energy to Pump Water*. Texas Cooperative Extension, Texas A&M University System, Bryan, Texas.
- Ironwindmill, 2015:** *How Water Pumping Windmills Work*. Accessed from [www.ironmanwindmill.com/how-windmills-work.htm](http://www.ironmanwindmill.com/how-windmills-work.htm) (25 August 2015).
- Malhotra, S., 2011:** Selection, Design and Construction of Offshore Wind Turbine Foundations. In Al-Bahadly, I. (ed.), 2011: *Wind Turbines*, InTech.
- Ministry of Water Resources and Irrigation (MWRI), 2014:** *Water Scarcity in Egypt*. Source?
- Moore, K., 2008:** Pumping Water with the Wind, *Home Power Magazine*, 122, 88-93.
- Moussa, A.S., 2000:** Wind Energy in Egypt, NREA, *DEWI Magazine*, August 2000.
- Mortensen, N.G., 2006:** *Wind Atlas for Egypt*. New and Renewable Energy Authority, Cairo.
- Mwangi, P., 2012:** *Design of a Wind/Solar Hybrid System for Water Pumping*. University of Nairobi.
- Nachmany, M., 2015:** *Climate Change Legislation in Egypt*. An Excerpt from the 2015 Global Climate Legislation Study, The Grantham Research Institute on Climate Change.
- Omer, M.,** Wind Mechanical Engineering: Energy for Water Pumping in Rural Areas in Sudan, *Journal of Engineering and Technology*, accessed from <http://www.academypublish.org/papers/pdf/47.pdf> (3 August 2015).
- Probst, O., Martinez, J., Elizondo, J., and Monroy, O., 2011:** *Small Wind Turbine Technology*. InTech.
- Salah, M., 2015:** *Future of Renewable Energy in Egypt*. NREA / Ministry of Electricity and Renewable Energy.
- Salim, M.G., 2011:** Selection of Groundwater Sites in Egypt, *Journals of Cairo University*, 3(1), 11-19.

**Salmonsén, S. and Thoresson, H., 2010:** *Windmill Driven Water Pump for Small-Scale Irrigation and Domestic Use in Lake Victoria Basin*. University of Skövde, Skövde.

**Shepherd, D., 1990:** *Historical Development of the Windmill*. National Aeronautics Administration.

**Stuck, D., 2010:** *Windmill Water Pumps: Comparison*. Accessed from <http://goo.gl/bfemO3> (26 August 2015).

**The Intergovernmental Panel on Climate Change (IPCC), 2001:** *Climate Change 2001: Impacts, Adaptation and Vulnerability*. Press Syndicate of the University of Cambridge, Cambridge, United Kingdom.

**Trunz, R., 2010:** *Water Pumping Windmills*. Auroville Green Practices Seminar 2010, 26-28 August, 2010.

**UNDP, 2006:** *Water Scarcity*. Accessed from [http://www.unwater.org/fileadmin/user\\_upload/unwater\\_new/docs/A4%20template%20\(water%20scarcity\).pdf](http://www.unwater.org/fileadmin/user_upload/unwater_new/docs/A4%20template%20(water%20scarcity).pdf) (26 August 2015).

**U.S. Energy Information Administration (EIA) (2015):** *Egypt International Energy Data and Analysis*. Accessed from <http://www.eia.gov/beta/international/analysis.cfm?iso=EGY> (26 August 2015).

**Zubrycki, K., Crawford, A., Hove, H. and Parry, J.-E., 2011:** *Review of Current and Planned Adaptation Action: North Africa*. UNDP Adaptation Learning Mechanism. Accessed from <http://www.undp-alm.org/explore/northern-africa> (20 August 2015).

# Solar Energy Sustains Universal Self-Reliance in Water Supply

Heba Salama<sup>(1)\*</sup>, Mohammad A. Rahman<sup>(2)</sup>, Chicgoua Noubactep<sup>(3)</sup>

(1) Crop Science Department, Faculty of Agriculture, Alexandria University, Egypt ; (2) Institut für Strömungsmechanik und Umweltphysik im Bauwesen, Leibniz Universität Hannover, D-30167 Hannover, Germany;

(3) Angewandte Geologie, Universität Göttingen, Goldschmidtstraße 3, D-37077 Göttingen, Germany.

\*contact: [heba1942001@yahoo.com](mailto:heba1942001@yahoo.com)

## Abstract

Meeting current and future drinking water quality demands depends on the capability of the scientific community to present efficient and affordable solutions. The ideal solution works under conditions prevailing in remote areas without access to any electricity grid. The needed electricity, if applicable, should be generated locally. The use of metallic iron in filtration systems ( $\text{Fe}^0$  filters) has been identified as such an affordable technology. This article summarizes the technical feasibility of  $\text{Fe}^0$  filters as a holistic process operating at room temperature, atmospheric pressure, and neutral pH values for safe drinking water provision. The basic system is gravity-driven. Ways have been explored as to how using solar energy (SE) would simplify operation and monitoring. In particular, SE may have four key functions: (i) pumping the ‘raw water’ to a storage tank, (ii) regulating the flow regime out of the storage tank, (iii) controlling the temperature of the  $\text{Fe}^0$ - based units, and (iv) pasteurizing the stagnant treated water. Integrated  $\text{Fe}^0$  filters/SE systems are a promising water treatment technology for small communities.

**Keywords:** Drinking Water,  $\text{Fe}^0$  Filters, Frugal Innovation, Zero-Valent Iron.

## 1. INTRODUCTION

Over the past five decades, decentralized safe drinking water provision for households and small communities has been intensively practiced (Hussam, 2009; Noubactep, 2010; Shannon et al., 2008). A key issue for the design of a treatment technology for such communities is whether water can be adequately treated to ensure drinking quality (Shannon et al., 2008). Many treatment processes have been tested and used in these efforts (Noubactep et al., 2009; Shannon et al., 2008), from which only membrane processes can simultaneously remove a wide spectrum of aqueous contaminants in a single reactor (Noubactep et al., 2009). Membrane

processes are energy-intensive and need high capital and operating costs. Their application is thus prohibitively expensive for low-income communities and locations without access to electricity grids. Therefore, innovative, efficient and affordable compact technologies are still highly needed for decentralized water supplies.

During the last fifteen years Fe<sup>0</sup> filters have been successfully used to eliminate aqueous chemical and microbial contamination (Khan et al., 2000; Bradley et al., 2011; Gheju, 2011; Rahman et al., 2013). These systems are gravity-driven and function under ambient conditions (pressure, temperature) and at circumneutral pH values (Caré et al., 2013; Ghauch, 2015; Noubactep et al., 2012). These findings are in agreement with ancient practices using Fe<sup>0</sup> as a source of iron oxides (James et al., 1992) but disprove the view still popular in the recent scientific literature that Fe<sup>0</sup> is a reducing agent under ambient conditions (Guan et al., 2015; Noubactep, 2015). Despite working on a false premise, the Fe<sup>0</sup> technology research has provided the demonstration of the efficiency of Fe<sup>0</sup> filters as presented herein. Clearly, no feasibility studies are needed, thus, only a proper design is required.

## 2. SUITABILITY OF Fe<sup>0</sup> FILTERS

Immersed reactive Fe<sup>0</sup> is corroded by water and resulting Fe<sup>2+</sup> is hydrolyzed and polymerized to ferrous hydroxides (Eq. 1). The primary oxidation products of Fe<sup>0</sup> are Fe<sup>2+</sup> and H<sub>2</sub>, which are reducing agents. This means that when a species (including dissolved O<sub>2</sub>) is reduced in a Fe<sup>0</sup>/H<sub>2</sub>O system, electrons are not necessarily from Fe<sup>0</sup>. Thus, reduction in the presence of Fe<sup>0</sup> (Fe<sup>0</sup>/H<sub>2</sub>O system) is not equal to reduction by Fe<sup>0</sup> (Noubactep, 2015).

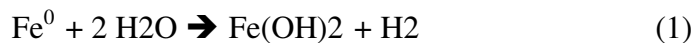

Contaminants are removed in Fe<sup>0</sup>/H<sub>2</sub>O systems by three possible mechanisms: (i) adsorption, (ii) co-precipitation and (iii) size-exclusion. Clearly if a species is chemically reduced, its reaction products (metabolites) still need to be removed from the aqueous phase by one of the three aforementioned mechanisms.

Adsorption occurs at the surface of iron corrosion products generated within the Fe<sup>0</sup> filters. Co-precipitation occurs during the precipitation of iron corrosion products by virtue of the low solubility of iron at pH > 4.5. Size-exclusion of contaminants is favored by the volumetric expansive nature of iron corrosion (Caré et al., 2013). Fe<sup>0</sup> volumetric expansion implies that pure Fe<sup>0</sup> beds (100 % Fe<sup>0</sup>) are not sustainable (Hussam, 2009). The ideal volumetric Fe<sup>0</sup>-to-aggregate ratio is 25:75 (or 1:3). Relevant aggregates include gravel, pumice and sand (Tepong-Tsindé et al., 2015). Basically all contaminants are removed by co-precipitation and size-exclusion. However, contaminants having a better affinity to positively charged iron oxides and hydroxides are better removed (Phukan et al., 2015). These include arsenic, fluoride and uranium (Tepong-Tsindé et al., 2015). Beyond these thermodynamic arguments, the universal suitability of Fe<sup>0</sup> filters for decentralized safe drinking water provision arises from the evidence



that reactive  $\text{Fe}^0$  is available worldwide, for instance as iron nail, scrap iron or steel wool. The additional fact is that this simple concept, using rationale design with a focus on self-reliance (Caré et al., 2013; Noubactep et al., 2012; Tepong-Tsindé et al., 2015), makes  $\text{Fe}^0$  filters a frugal innovation par excellence.

### 3. DESIGNING $\text{Fe}^0$ FILTERS

Designing a  $\text{Fe}^0$  filtration system starts by selecting an appropriate reactive  $\text{Fe}^0$ . Figure 1 proposes a base water treatment facility for a small community. The system is composed of five tanks: (i) raw water, (ii) slow sand filter (SSF), (iii)  $\text{Fe}^0$  filter ( $\text{Fe}^0/\text{sand}$ ), (iv) fine sand filter, and (v) the clean water. The  $\text{Fe}^0/\text{sand}$  is the heart of the system and is filled with specially prepared  $\text{Fe}^0/\text{sand}$  mixture to achieve the required treatment for a given volume of raw water flowing at a certain velocity (gravity-driven) through the treatment chain. The design of Figure 1 allows the initiation of a treatment event by filling the raw water tank and emptying the clean water tank. Filtration will stop automatically when the clean water tank is full. A site-specific design might imply that several tanks of the same nature (e.g.  $\text{Fe}^0/\text{sand}$ ) be arrayed in series to achieve the treatment goal.

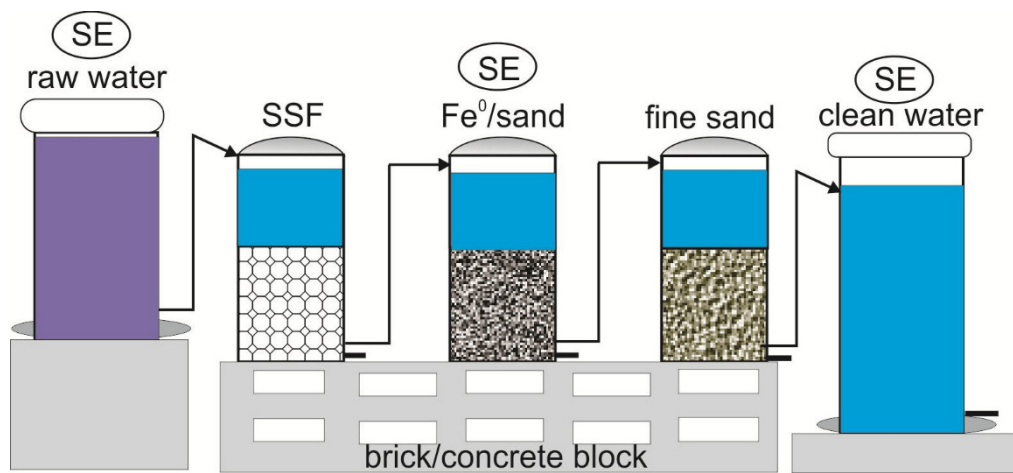

**Figure 1:** Side view of the treatment chain specifying the positions where solar energy (SE) is expected to optimize operation and monitoring. SSF also lowers the  $\text{O}_2$  level and thus contributes to extending  $\text{Fe}^0$  service life.

### 4. ENERGY SELF-SUFFICIENCY FOR SELF WATER-SUFFICIENCY

In a speech addressed to the World Health Assembly (2001), the then UN Secretary General Kofi Annan said: “The biggest enemy of health in the developing world is poverty.” Poverty forces people to live hungry in poor environments without decent shelter, clean water or adequate sanitation. These people are thus vulnerable to disease. However, they do not have access to reliable health services and affordable medicine. Their children do not have

access to routine vaccinations nor to scholarly education. Efforts to combat poverty at a world scale date back to the 1970s, but the progress achieved (including achieving the UN MDG) is miserable.

Access to safe drinking water is the pillar of good health. Good health protects the society from vulnerability, so improving the health of the poor is a priority for all sectors of development. As Kofi Annan once said “We shall not finally defeat AIDS, tuberculosis, malaria or any of the other infectious diseases that plague the developing world until we have also won the battle for safe drinking water, sanitation and basic health care ...”

The presentation above has already identified a well-designed gravity-driven  $\text{Fe}^0$  filtration system as a potential solution for universal access to safe drinking water. This section will discuss how using solar energy can improve self-reliance in water supplies at a community level (e.g. health posts, households, micro-enterprise, rural communities, schools). That is, simplifying and/or maximizing the operation and efficiency of  $\text{Fe}^0$  filters using solar energy. Five main axes are relevant: (i) pumping the contaminated water to the storage tank, (ii) rendering the operation of  $\text{Fe}^0$  filters automatic, (iii) optimizing filter operation by regulating the temperature of the  $\text{Fe}^0$  filters, (iv) disinfecting filtered (stagnant) water in the distribution tank, and (v) remote monitoring of filter efficiency.

Solar energy is the simplest desalination technology, it is also conventionally used for water disinfection and can be used to power (i) pumps, (ii) ultraviolet (UV) systems, (iii) photocatalysis, (iv) reverse osmosis (RO), and (v) conventional surface-water treatment systems. While these conventional uses are abundantly described in the literature, this section is limited to succinctly present ‘solar energy for  $\text{Fe}^0$  filters’.

Solar radiation impinging on the surface of semiconductors produces solar energy by electromagnetic means. The smallest semiconductor material is a PV cell. The maximum voltage from a single silicon cell is about 600 mV. Usually, several cells are connected in series to obtain the desired voltage. Currently available standard PV modules range in output from less than 2 W to about 110 W. The PV module constitutes the basic building block from which any size PV array can be configured to suit the application.

## **5. SOLAR PUMPS**

Solar pumps are alternative to diesel/gasoline/kerosene pumps, grid-connected electric pumps, wind pumps, biofuel pumps, animal-drawn pumps, and hand pumps. Generally, they incur a high investment cost. This cost can be offset by a long service life since operation and maintenance (O&M) costs are minimal over its economic life. Solar pumps are a very reliable technology and can be matched quite closely to the amount of water needed. A careful

assessment of the solar energy resource and water demand is needed. Water tanks should be adequately designed to cope with local solar radiation.

## **6. AUTOMATION OF THE Fe<sup>0</sup> FILTRATION SYSTEM**

The operation of conventional gravity driven Fe<sup>0</sup> filters can be optimized by automation. Several energy-dependent options are possible and include: (i) controlling the water flow velocity, for example 10 L/h for a module designed to produce 240 L/d, or (ii) delivering just 240 L/d to the gravity-driven Fe<sup>0</sup> system. In both cases, the system had to be designed to avoid dry periods within the filters (controlled hydraulic heights).

## **7. OPTIMIZING THE OPERATING TEMPERATURE**

The filter operation may need constant temperature to work optimally, for instance 25 or 40 °C. Controlling the temperature of Fe<sup>0</sup>-based columns (Figure 1) using solar energy will elegantly achieve this aim. Remember that the heart of Fe<sup>0</sup> filters is in the oxidative dissolution of Fe<sup>0</sup> followed by oxide precipitation. Both reactions are temperature-dependent.

## **8. WATER DISINFECTION (PASTEURIZATION)**

Water from Fe<sup>0</sup> filters is (ideally) cleaned using chemical and microbial procedures. If not, microbial contamination may occur upon stagnation. In many developing countries, chlorine is used to disinfect water (destroy and avoid the proliferation of pathogens). However, people lack knowledge about the amount of chlorine to apply and the resources to purchase the chemical. Thus, using solar energy for the pasteurization of water from the Fe<sup>0</sup> filter (e.g. twice a week) will eliminate the possibility of post-contamination. Pasteurization systems have been installed at some locations and have been working well for some years. The originality of the system proposed herein is that solar energy be coupled with water filtration and that a system be customized to take advantage of all aspects of each involved component.

## **9. REMOTE MONITORING**

Solar energy could complete the infrastructure to the Fe<sup>0</sup> filtration technology by enabling a remote monitoring of the system performance. Essential parameters such as pH value, concentrations of the contaminants, hydraulic conductivity (permeability) of both contaminated and treated water can be automatically recorded and the results periodically sent via instant message to the operator office, in a central station or city, for example. This option would also support research and development by helping researchers (e.g. PhD candidates) reduce the number of sample collection campaigns.

## 10. CONCLUSIONS

Fe<sup>0</sup>-mediated water treatment has been established for environmental remediation and is progressively scaled down for safe drinking water provision at a small scale. A wide variety of differently charged organic and inorganic chemicals (cationic, anionic, and neutral) and pathogens (bacteria, viruses) has been removed via adsorption, co-precipitation, and size-exclusion. This distinctive capacity is ascribed to in-situ production and transformation of iron hydroxides and oxides. While well-designed gravity-driven Fe<sup>0</sup> filters are promising for decentralized safe drinking water provision, this contribution has outlined how low-energy sources may offer simplification in operation and monitoring of such filters. Further theoretical studies (including modeling) of the system design is needed to prepare for large-scale implementation of such systems.

## REFERENCES

- Bradley, I., Straub, A., Maraccini, P., Markazi, S., Nguyen, T.H., 2011:** Iron Oxide Amended Biosand Filters for Virus Removal. *Water Research*, 45, 4501–4510.
- Caré, S., Crane, R., Calabro, P.S., Ghauch, A., Temgoua, E., and Noubactep, C., 2013:** Modelling the Permeability Loss of Metallic Iron Water Filtration Systems, *Clean - Soil, Air, Water*, 41, 275–282.
- Ghauch, A., 2015:** Iron-Based Metallic Systems: An Excellent Choice for Sustainable Water Treatment, *Freiberg Online Geoscience*, 32, 80.
- Gheju, M., 2011:** Hexavalent Chromium Reduction with Zero-Valent Iron (ZVI) in Aquatic Systems, *Water, Air, and Soil Pollution*, 222, 103–148.
- Guan, X., Sun, Y., Qin, H., Li, J., Lo, I.M.C., He, D., and Dong, H. 2015:** The Limitations of Applying Zero-Valent Iron Technology in Contaminants Sequestration and the Corresponding Countermeasures: The Development in Zero-Valent Iron Technology in the Last Two Decades (1994–2014), *Water Research*, 75, 224–248.
- Hussam, A. 2009:** Contending With a Development Disaster: SONO Filters Remove Arsenic from Well Water in Bangladesh, *Innovations*, 4, 89–102.
- James, B.R., Rabenhorst, M.C., and Frigon, G.A., 1992:** Phosphorus Sorption by Peat and Sand Amended with Iron Oxides or Steel Wool, *Water Environment Research*, 64, 699–705.
- Noubactep, C., Schöner, A., and Wofo, P., 2009:** Metallic Iron Filters for Universal Access to Safe Drinking Water, *Clean – Soil, Air, and Water*, 37, 930–937.
- Noubactep, C., 2010:** Metallic Iron for Safe Drinking Water Worldwide, *Chemical Engineering Journal*, 165, 740–749.

**Noubactep, C., Temgoua, E., and Rahman, M.A., 2012:** Designing Iron-Amended Biosand Filters for Decentralized Safe Drinking Water Provision, *Clean - Soil, Air, and Water*, 40, 798–807.

**Noubactep, C., 2015:** Metallic Iron for Environmental Remediation: A Review of Reviews, *Water Research*, 85, 114–123.

**Phukan M., Noubactep C., and Licha T., 2015:** Characterizing the Ion-Selective Nature of Fe<sup>0</sup>-Based Filters Using Azo Dyes, *Chemical Engineering Journal*, 259, 481-491.

**Rahman, M.A., Karmakar, S., Salama, H., Gactha-Bandjun, N., Btatkeu, K. B.D., and Noubactep C., 2013:** Optimizing the Design of Fe<sup>0</sup>-Based Filtration Systems for Water Treatment: The Suitability of Porous Iron Composites, *Journal of Applied Solution Chemistry and Modeling* 2, 165–177.

**Shannon, M.A., Bohn, P.W., Elimelech, M., Georgiadis, J.G., Marinas, B.J., and Mayes, A.M. 2008:** Science and Technology for Water Purification in the Coming Decades, *Nature*, 452, 301–310.

**Tepong-Tsindé R., Crane R., Noubactep C., Nassi A., and Ruppert H. 2015:** Testing Metallic Iron Filtration Systems for Decentralized Water Treatment at Pilot Scale, *Water*, 7, 868–897.

# **A Solar Water Pumping Solution Based on Industrial Variable Speed Drive (VSD) Technology**

Mustafa Lotfy

Electrical engineer at ERCC Company & M.Sc. student at faculty of engineering, Alexandria University.

Maamora, Alexandria, Egypt

Mobile: +20 (0)10 10288685

**Emails:** [Mustafa.lotfy@ercc-carbon.com](mailto:Mustafa.lotfy@ercc-carbon.com)  
[Mustafa.m.lotfy@gmail.com](mailto:Mustafa.m.lotfy@gmail.com)

## **ABSTRACT**

This paper presents a solar water pumping solution based on an industrial variable speed drive (VSD). The proposed solution was tested on a 3 hp centrifugal pump powered by 2.43 kWp of solar panels and controlled by a 2.2 kW VSD. The use of industrial VSDs for solar water pumping has numerous advantages: large power range, cost effectiveness, and wide availability. The proposed control algorithm applied to an industrial VSD achieves the following functions: (1) automatic start based on irradiation levels without the need for manual intervention; (2) maximum power point tracking to extract maximum power from the PV modules, maximizing the amount of water that can be pumped for a given investment; (3) avoidance of Low Voltage Trip during cloudy weather or losses of irradiation; (4) smooth and fast response to sudden changes in irradiation. These functions have been demonstrated on the test pump system in Kafr El Sheikh. Results and observations are presented in this paper.

**Keywords:** PV Pumping, Maximum power point tracking (MPPT) Solar water pumping, VSD.

## **1. INTRODUCTION**

Water has become one of the most important limitations worldwide in agriculture and increases reclaimed lands in desert and rural areas. A solar water pumping system provides a secure and sustainable source of water. It aims to increase the country income and investments in deserts and agricultural sectors. This system solves the problem of electricity and fuel shortages in such areas and offers an environmental solution of reducing carbon emissions that result from the use of fossil fuels.

For years VSDs used to drive the centrifugal pumps in industrial applications to control the flow of the fluid and provide energy saving solutions. In industrial applications, the VSDs are supplied by an AC voltage source supply. In our solution, PV modules are coupled with the DC bus of VSDs. The challenge is to match the characteristic of PV with standard features of VSDs by avoiding the occurrence of low voltage DC trip and applying a maximum power point algorithm, auto starting, and smooth and fast response in case of sudden changes in the input

source. This paper will discuss the applied control to VSDs to achieve those features. This paper consists of the following sections: I) Introduction, II) Solar water pumping systems, III) Description of system components, IV) Algorithm of the proposed system components, V) Experiment results, VII) Conclusion, VIII) References.

## 2. SOLAR WATER PUMPING SYSTEMS

Depending on the presence of an electrical storage system (battery), solar water pumping systems can be classified into solar water pumping with battery and solar water pumping without battery. Storing electrical energy in batteries enables the pump to work at night and in cloudy weather, but this system also has disadvantages: the presence of batteries reduces the total system efficiency, increases the system cost and maintenance required, and decreases the lifetime of the system. The lifetime of the battery is about 20% of the lifetime of PV Modules. However, water storage systems (water tanks, reservoirs) offer a simple and economically viable way of storing water with reduced maintenance, instead of storing electricity (M.Abu-Alligah, 2011). However, a PV system without batteries faces an additional challenge to deal with the stochastic nature of solar irradiance (Reddy and Rao, 2013).

## 3. DESCRIPTION OF PROPOSED SYSTEM COMPONENTS

Our proposed system is a direct decoupled system without a battery. It consists of a string of nine modules, each one is 270 Wp. The nine modules are connected in series. The string voltage is connected directly to the DC bus voltage of 2.2 kW Parker variable speed drive. The three-phase output of the variable speed drive is connected to three-phase induction motor, which is coupled to a 3 hp centrifugal pump. Figure 14 shows the system components.

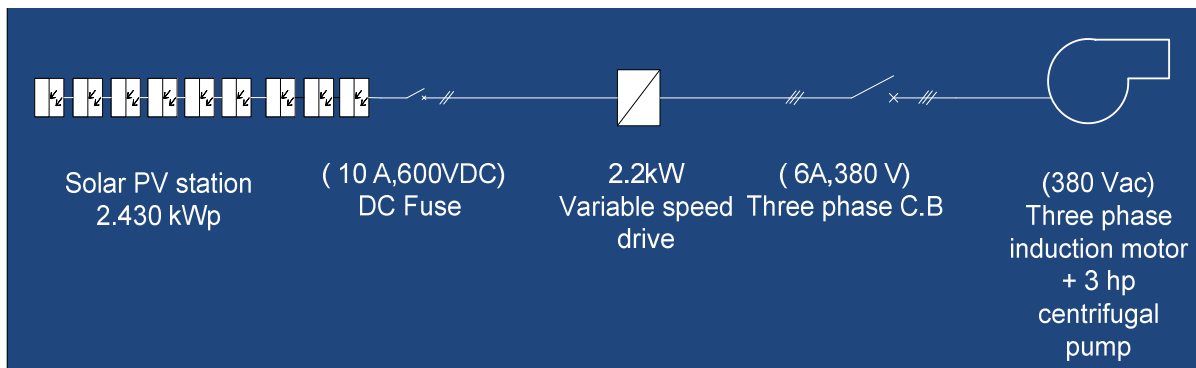
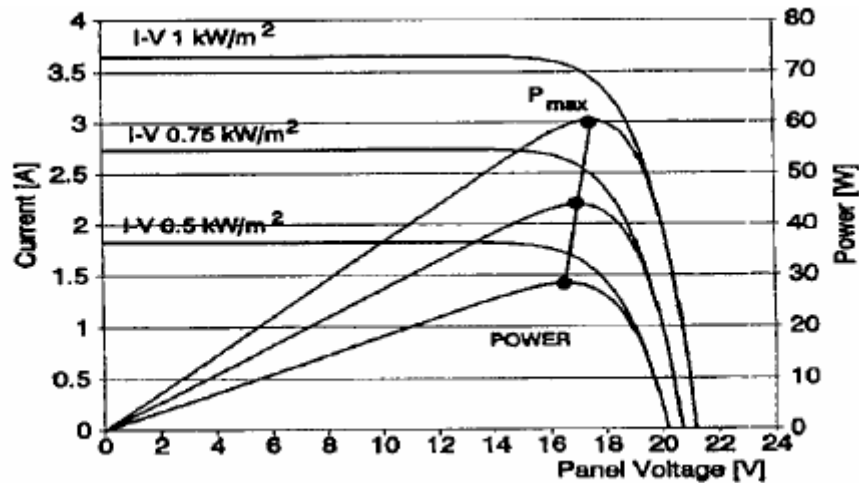

**Figure 1:** A configuration of the proposed solar water pumping system

### PV cell characteristic

The PV cell converts the solar radiation to electrical energy. The PV cell is a nonlinear power source. The nonlinear behavior of the PV is illustrated in Figure 15. The solar irradiance and module's temperature are the main parameters that affect the PV's output. The optimum

operating point that can deliver the maximum power from the PV modules is called the Maximum Power Point (MPP). There are several MPP techniques to make this point the system's operating point to generate the maximum power from the PV module. The PV cells are connected in parallel and in series to increase the voltage and current consequently. Figure 15 shows the characteristics of PV modules at different irradiance levels (Vongmanee, 2005).



**Figure 2:** The characteristic of the PV cell at different irradiance levels

**a) Industrial variable speed drives**

The variable speed drive is a device that controls and regulates the speed or torque of a wide range of electrical motors. Those drives are used to match the speed or torque to the process requirement or to save energy and improve efficiency (Barnes, 2005).

**b) Centrifugal pump**

The centrifugal pumps are widely used in irrigation and industrial fluid pumping applications due to their cost effectiveness, simplicity and availability in a wide range of flow rates and heads, and the lower amount of maintenance they require (Pachauri and Chauhan, 2014). This type of pump can drive a high flow rate of water and operates at high efficiency. The centrifugal pumps are more compatible with PV pumping applications as they can operate for long periods, even in low irradiance conditions, and their load characteristics can deliver maximum power from the PV panels (Aashoor and Robinson, 2013).

**4. CONTROL ALGORITHM**

The PV string is connected directly to the DC bus of VSD. The control algorithm fulfills the following functions:



### (1) Automatic start without the need for manual intervention

The PV characteristics change due to irradiance levels and the module's temperature variations. Assuming that the changes in PV temperature are not significant in the early morning, they will depend only on the irradiance level. PV string simulation was performed with MATLAB Simulink software to find the relationship between open circuit voltage (Voc) and different irradiance levels. Figure 16 shows the relation between the Voc and different solar irradiance levels. VSD measures the input voltage internally without the need of installing any external sensors or transducers. The DC bus voltage is compared to 460 VDC (the Voltage at irradiance level  $65 \text{ W/m}^2$ ) to give a trigger signal to the VSD to start the pump operation.

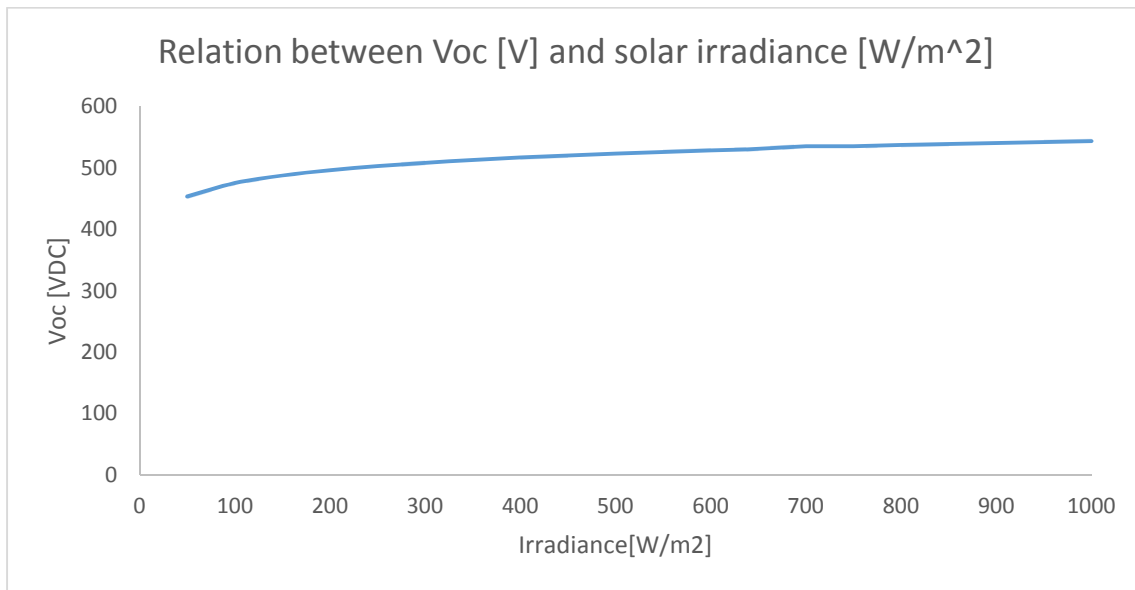

**Figure 3:** Relation between Voc [V] and solar irradiance [W/m<sup>2</sup>]

### (2) Maximum Power Point Tracking (MPPT) Technique

The MPPT technique is applied to extract maximum power from the PV modules, maximizing the amount of water that can be pumped for a given investment. A constant voltage MPPT technique offers more energy utilization efficiency than direct decoupling without applied MPPT. By increasing or decreasing the loading speed (frequency), the rotating speed of the motor will also increase or decrease. According to affinity law (Martiré et al., 2005),

$$Q \propto n,$$
$$H \propto n^2,$$
$$P \propto n^3,$$

Where  $Q$  refers to flowrate,  $H$  to water head,  $P$  to Power and  $n$  to rotor speed.

By increasing the rotor speed, the consumed power by the pump will increase and vice-versa in the case of decreasing the rotor speed. The MPP algorithm makes the VSD work at maximum available speed to extract the maximum power. After starting the VSD, as the VSDs do not have internal memory, the remote set point of the speed of the drive comes from two sources, initial

speed 85% and the difference between the measured DC bus voltage compared with set point 455 VDC (Maximum Power Point Voltage [Vmpp] at STC).

### (3) Adjust PI control parameters:

The low voltage error of VSD is the most common issue of using this technology in pumping applications. By adjusting the tuning of PI control parameters, the operating point will be forced near the set point and give a fast and rapid response during the sudden change and force the loading speed of VSD to decrease to match the sudden input power from the PV station without the occurrence of low voltage DC trip. The maximum power point algorithm forces the VSD to work on the maximum speed (the maximum power) but in case of a lack of sufficient power to achieve the required speed, the low voltage DC trip will occur. The PI solved this issue by adjusting the tuning parameter of PI control. Different values of speed proportions and integral gain time were tried, but at  $K_p=1$  and  $t_i=0.1$  sec, the best performance was achieved on a heavily cloudy day without occurrence of low voltage DC trip.

## 5. EXPERIMENT RESULTS

The proposed solution was tested on a heavily cloudy day, which represents the extreme test conditions to measure its functions. Figures 17 and 18 show the output response of output AC power and the output response of rotating speed. These data are measured and stored by DSE Parker Drive software.

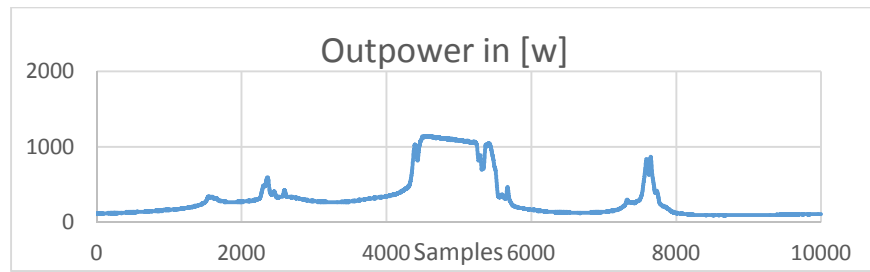

**Figure 4:** The output response of output AC power from the drive

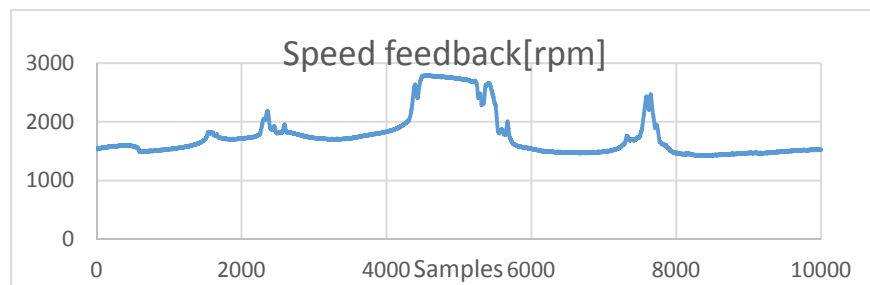

**Figure 5:** The output response of rotor speed [rpm]

These curves show the smooth speed variations and the drive operation without low voltage trip occurrence.

Figure 19 shows the output water at 10:31 am from the proposed solar water pumping system based on VSD technology.



**Figure 13:** Output water from the proposed solar water system based on VSD technology at 10:31 am

## 6. CONCLUSION

This paper suggests using VSDs for solar water pumping applications and the methodology to achieve the features of auto-starting, maximizing the absorption power from PV using MPP techniques, avoiding occurrence of low voltage DC trip and getting a fast and rapid performance. The validity of these solutions has been tested in a real system.

## REFERENCES

- Aashoor, F.A.O. and Robinson, F.V.P., 2013:** *Maximum Power Point Tracking of Photovoltaic Water Pumping System Using Fuzzy Logic Controller*. Power Engineering Conference (UPEC), 2013.
- Abu-Aligah, M., 2011:** Design of Photovoltaic Water Pumping System and Compare it with Diesel Powered Pump, *JJMIE*, 5(3), 273-280.
- Barnes, M., 2005:** *Practical Variable Speed Drives and Power Electronics*. Elsevier, Oxford.
- Pachauri, R.K. and Chauhan, Y.K., 2014:** Fuzzy Logic Controlled MPPT Assisted PV-FC Power Generation for Motor Driven Water Pumping System, *2014 IEEE Students' Conference on Electrical, Electronics and Computer Science*, 1-6.
- VijayaBhaskar Reddy, K. and Siva Krishna Rao, G.V., 2013:** Experimental Results of Photovoltaic Powered Induction Motor Drive for Pumping, *Research India Publications*, 3(2), 193-204.
- Vongmanee, V., 2005:** *The Photovoltaic Water Pumping System Using Optimum Slip Control to Maximum Power and Efficiency*. Power Tech, 2005 IEEE, Russia.

# **The Social Side of Water – Sustainability and Community Management of Solar Water Stations in the Oases of Egypt’s Western Desert**

Martina Jaskolski  
Research Institute for a Sustainable Environment  
The American University in Cairo  
[tinajas@aucegypt.edu](mailto:tinajas@aucegypt.edu)

## **ABSTRACT**

This paper discusses the management aspects of a technical solution that makes available healthy drinking water for rural Egyptian communities by using an innovative, solar powered and sustainable technology. In 2014, the Research Institute for a Sustainable Environment (RISE) of the American University in Cairo, in partnership with the German company AUTARCON, funded by HSBC, installed two pilot stations in the remote oases of El Heiz and Abu Minqar, located in the heart of Egypt’s Western Desert. In order to make the local projects sustainable beyond their successful installation requires the development and implementation of long term management and pricing plans. The two described cases show that the feasibility and success of such a technology varied among the villages, especially when local residents had to mobilize social capital to organize the long-term operation of their new water stations. The case studies also show how history, social structures and community cohesion, as well as the ability to self-organize became important variables as residents struggled to develop ways of ensuring both short and long-term sustainability of their stations. The stations here became new local actors granting local residents new access to a shared local resource. This paper recounts how the two communities negotiated the terms of this access.

## **1. ACCESS TO HEALTHY DRINKING WATER – A MILLENNIUM GOAL WITH COMPLEX SOCIAL IMPLICATIONS**

One of the Millennium Development Goals was to halve the number of people worldwide with inadequate access to water and sanitation (UN, 2016), which is often described as a result of policy failure rather than real, environmental and resource constraints (Loftus, 2009). The UN claims that this goal has been met on a global scale and in most regions (UN, 2015). In Northern Africa, according to UN (2015) figures, the percentage of the population using an improved drinking water source increased from 87% to 95% between 1990 and 2015, which means the percentage of those without access to improved drinking water sank from 13% to 7 %, almost achieving the MDG. RISE works in areas of Egypt where not every community has access to improved drinking water. Moreover, even in communities where treated water is provided, the quality is often still not good enough for drinking straight from the tap, as no or insufficient amounts of chlorine are being added and the water still has a high iron content. Thus, efforts by

government, NGOs, donor agencies and the private sector aim to find solutions for a dilemma that, despite the MDG's achievements, continue to global proportions.

Technical approaches to the provision of drinking water in rural areas are plentiful. This paper discusses the social implications of the implementation of a new technology called SuMeWa (Sun Meets Water), developed by the German company AUTARCON (described in more detail elsewhere in these conference proceedings) in two rural communities in Egypt. In the context of sustainable development, seemingly straightforward, top-down technology transfer has been replaced by more community-based, participatory ways of project implementation that strive towards involving communities at all project stages, including project design, implementation and follow-up. Participatory approaches that enable key stakeholder involvement and the integration of different interests and spheres are not only seen as an intrinsic component of sustainability, such as stated in early international sustainability blueprints such as Agenda 21 (United Nations, 1992), but have also driven approaches to research (Delemos, 2006) and development, governance and education for decades, leading to assessment of both the approach's merits and limitations (Allam, 2004; Dahle, K., 1998; Freeman et al., 2003; Jaskolski, 2008 and forthcoming; Mohan, 2006; Pain and Francis, 2003).

One important challenge in the participatory implementation of technical solutions such as drinking water filtration systems is the interest, support, and engagement of local communities. In order to make sure a technical solution meets wide-spread village support, the type of solution selected for a village should not only be determined by the physical and infrastructure context that would set the parameters for the solution, but also the social and cultural values and practices that would shape its operation. For example, community assessments carried out by the Research Institute for a Sustainable Environment among dispersed families living in the mountain valleys of the Eastern Desert Valleys along Egypt's Southern Red Sea coast have shown that, although technical solutions to extract clean drinking water from local wells do exist, the community insists on traditional methods of water extraction by bucket, and simply will not accept any other method of water extraction. Thus, the social and cultural parameters pose significant limitations to the choice of technical solutions available for a location, and they also significantly impact the solution's long-term operational success and sustainability. In the Western Desert, the red water was a problem agreed upon by all groups of the community, and initial stakeholder meetings showed wide-spread support for the AUTARCON system. Given RISE's nine year experience researching water management in the oases of the Western Desert and implementing community sustainability projects, the project team was able to build on pre-established local trust and existing social ties with members of the two communities.

RISE's project experience working with remote desert communities has shown that the maintenance and long-term management of community development projects and solutions is one of the biggest sustainability challenges. In this context, understanding the historical, social and cultural dimensions of a community is key to selecting appropriate solutions and building the trust that is required for implementing a new technology in a village. As a new piece of technology is implemented in a community, the operation and long-term management of the

technology falls into the responsibility of the community, requiring a substantial level of social organization and social capital on the part of the community. Social capital is a theoretical concept defined as relationships of mutual trust and reciprocity that shape a community's ability to act facilitate and maintain social and economic transactions. Social capital has been linked to the improved economic performance of a community (Putnam, 2000) as well as communities' capacity to respond to resource shortages, environmental disaster and climate change (Adger, 2003). In this case, the concept can be used to theorize how a community can facilitate the operation and management of a piece of technological innovation by relying on exiting social structures a developing new ones.

Technical innovations such as a new drinking water station change the way humans are giving access to a natural resource. As political ecologists have pointed out, “[p]rocesses of socio-environmental change are ... never socially or ecologically neutral”, since it is “economic and political power relations through which access to, control over, and distribution of water is organized” (Swyngedouw, 2009, 57 and 58). Thus, transformations of the hydrological cycle, for example through drilling or giving people access to water, correlate with social, economic, political and power transformation (Swyngedouw, 2009). In what Sultana (2003) calls ‘technonatures’, there are always elements of politics and power linked to the type of technologies made available to communities, particularly those implemented by states. Sultana (2003) demonstrates how technologies such as tube wells can become social actors in a system of actors and networks that play a vital role in the way communities can access natural resources. Actor-network theory here helps with assessing how technologies bring about a change of social relations and networks of power: “Giving tubewells a social life and actor status enables us to view them not just as things but also as objects that embody social relations” (Sultana, 2013, 347). Molle et al. (2009) have shown how the management of water at the level of the state leads to complex water bureaucracies they call ‘hydrocracies’. At the village level, this term may seem inflated, but local communities providing their members with long-term, sustainable and affordable access to drinking water by means of a newly installed technology requires local actors and social networks to organize and mobilize social capital. This paper will show how the social dimensions of a village, including its social composition, social cohesion, social capital and gender relations can play a key role in the success and failure of a technical solution that, taken from an engineering point of view, should function.

## **2. METHODOLOGY**

This research is based on several years of fieldwork in the oasis communities of Abu Minqar and El Heiz. In Abu Minqar, research into the water management and farming system of the community started as early as 2006, in El Heiz research and development work was begun in 2013. The data used for this paper was gathered in conversations and interviews with local residents between 2009 and 2015, as well as focus groups, local water testing, research of well capacities and flow rates, as well as participatory action research tied to the installation of a drinking water filtration station in each community. During the installation of the AUTARCON

stations in 2014, other stakeholders such as the researchers, the implementing engineers and other project partners were interviewed. After implementation was completed, the researchers followed up on the success of the project through regular evaluation trips to the two oases, once even in presence of the engineers who implemented the system. During the same time, an additional three stations were installed, two in El Heiz and one in Abu Minqar.

### **3. DRINKING FOSSIL WATER – DRINKING WATER CHALLENGES IN THE OASES OF EGYPT’S WESTERN DESERT**

In the oases of the Western Desert, water has a naturally high iron content (Figure 1). Extracted from the depths of the Nubian Sandstone Aquifer, a finite reservoir of fossil water stored in the porous layers of sandstone rock (Burmil, 2003), this water has an extremely high iron content. Some areas additionally suffer from high levels of lead in the water (Soltan, 1999). In the untreated source water of El Heiz and Abu Minqar, the research team measured up to 7 mg of iron per liter in the water directly extracted from the aquifer, while water treated by the local government in Abu Minqar still contains 0.42 mg of iron per liter. The WHO (2004) contends that up to 2 mg per liter of drinking water are an acceptable amount and have no negative health effects and the secondary standards for drinking water quality in the US proclaim a maximum content of 0.3 mg per liter for iron (Water Research Center, 2014, electronic source). Iron remains more of a problem related to taste, color and turbidity (Figure 1). The real danger is that both treated and untreated water in the Western Desert do not contain enough chlorine to prevent the build-up of pathogens in plastic and clay containers during water transport and storage. In the case of existing government treatment stations, local operators often do not add the required amount of chlorine to the water. In the government drinking water station visited in Farafra, the team was told that chlorine had not been added to drinking water for the past twelve years. So, although the population officially has access to water according to the MDGs, the water quality is still sub-standard.



**Figure 1:** Backwash water displaying the high iron content (left) and water after filtration. Both samples are from the oasis of El Heiz in the Western Desert.



**Figure 2:** Egypt's Western Desert and the oases of El Heiz and Abu Minqar.

The oases of El Heiz and Abu Minqar extract water from the same aquifer and face the same problems of red, iron-rich water. El Heiz, is located in the same depression as the much larger oasis of Bahariya, around 40 km south of Bahariya's main town Bawiti and 400 km southwest of Cairo (Figure 2). El Heiz has around 3,800 inhabitants living in around 600 homes that are dispersed across seventeen hamlets within a 14 km radius. The collection of hamlets has inhabited for thousands of years, and archeological finds date back to hunter-gatherer times. The oasis also has a historic monastery from Roman times. The local population is organized around extended families with long histories in place, developing a culture of close family ties. The case study village, Ain Gomaa, one of El Heiz's main villages, consist of only a few extended families. El Heiz is an agricultural community focused mainly on date production, with some watermelon production during the spring months. The oasis' land is very fragmented, and most families own small pieces of land scattered across the different hamlets. Water for both irrigation and drinking is extracted from the Nubian Sandstone Aquifer at depths of around 350 meters. The drinking water well and most irrigation wells are operated by the government, while some farmers have drilled additional, private wells. The extended families of El Heiz are used to helping each other out with labor and agricultural tasks, often sharing their produce during the harvesting season.

The oasis of Abu Minqar, located about 650 km southwest of Cairo and about 250 km southwest of El Heiz on the same desert highway is a young oasis. Before the 1980s, Abu Minqar was known as a *hattia*, an uncultivated and not permanently inhabited place, only temporarily resorted to, for example to use a natural well (Harding-King, 1913). The place was then developed by the government as an agricultural company by drilling the Nubian Sandstone Aquifer at depths of 1,000-1,200 meters, before the company was closed down and the oasis was opened for desert settlers. As part of Egypt's strategy to populate the desert, several waves of settlers arrived in Abu Minqar under different settlement programs starting from the mid-1980s.



The community has thus become a somewhat artificial construct of settlers from all parts of Egypt with varying educational and cultural backgrounds. Four of Abu Minqar's six villages are exclusively Bedouin, or 'Arab', as the clans are locally called, while the other two house a mix of settlers from Dakhla oasis, the Delta and Upper Egypt. The village cultures vary significantly in cultural expression, for example marriage and wedding practices, clan language and cultural traditions. Despite this cultural diversity, interactions between villagers in Abu Minqar are generally peaceful. Abu Minqar's residents display a settler frontier attitude, they want their community to be successful. Abu Minqar, like El Heiz, is a farming community. However, the residents engage in the production of open field crops such as clover, wheat, maize and fava bean, reflecting growing habits of the Nile Valley and Delta rather than ancient desert cultivation practices.

#### **4. "OUR WATER IS RED...LIKE BLOOD"**

In the desert, waterscapes have a particular meaning, as permanent settlements were historically only possible where fissures in the under-bearing rock gave access to water in the form of an oasis. Water is what has shaped the landscape of the Western desert and continues to shape "oasis landscapes...[that are] transformed by the use of water resources for domestic life and agriculture" (Burmil, 2003). When asked about problems in their daily lives, the residents of both the oases of El Heiz and Abu Minqar often immediately refer to water – both for irrigation and domestic purposes. The high iron content in their water, and resulting red color, is seen by most residents as a major issue, such as by Gomaa Matarawi from the village of Ain Gomaa in El Heiz:

"The government doesn't listen to our problems. The water here is full of problems. The government provided wells for us, but these are located 1.5 km away. The water doesn't reach the oasis, and even if it did, it is full of iron. The water is red. Just like blood. If you put a white cloth in it, it immediately turns yellow or red. So we cannot drink from it" (Matarawi, 2014).

In Ain Gomaa, there is a drinking water well, which used to be operated by diesel pump and in early 2015 was equipped with a large solar pumping system installed by the Egyptian government with funding from the Gulf. There is, however, no functioning filtration process before this water, used for washing, cooking and drinking, reaches local household taps through a system of pipes. Several small drinking water filtration stations constructed between 2000 and 2010 either stopped working within their first few months of operation, or never worked a single day (Hosny, 2014).

Abu Minqar, in turn, has a large drinking water filtration station that was built in the year 2000 and filters 150 cubic meters per hour. The station operates 11 hours per day, making water accessible by tap inside local households. In the village of Talaat Dargham, which is located at a higher elevation than the drinking water well water taps only discharge water when the village generator is operating because water needs to be pumped up the hill to the village. This used to be for six hours in 2006 and was augmented to 20 hours in 2011. In order to be able to bridge the

times without water, local households are used to storing water in an array of containers in the house. Despite its large size, the station is not able to fully remove the iron from the water, and chlorine has not been added to the system for years. The lack of chlorine in the water does not prevent the growth of pathogens in the clay pots and jerry cans used to re-filter and store drinking water. The system is also unsustainable in the sense that it produces around 680 cubic meters of drainage and backwash water per day. This water is led straight into the drainage canal and not re-used at all, contributing to significant waste of fossil water each day.



**Figure 3:** Example of local residents’ use of clay pots filtering water that is then caught in plastic buckets.

In both El Heiz and Abu Minqar, local residents use traditional clay pots, *zirs*, to filter the water before drinking (Figure 3). These walls of these unglazed clay pots allow water to drip through drop by drop – freeing it from much of the iron and some bacteria. An elderly lady in the oasis of Abu Minqar, explains this process as follows:

“The water is bad, it’s red. We have to put the water in a plastic container for the sediment to settle. We then filter it through that *zir* [an unglazed clay jar], drop by drop... And then we put it through the *zir* once more before we can drink it. Without this procedure we are not able to drink good water” (Um Magdy, 2009).

This filtration process is not only labor-intensive and time consuming, it also does not free the water of all bacteria and viruses. During storage in plastic containers and jerry cans, often for a time of several days, water can become contaminated with bacteria that grow in the containers, making it unsafe for drinking. With no added chlorine, this bacteria and other pathogens cannot be fully kept at bay, despite the filtration process through the *zir*.

Although there is no medical evidence for this, the populations of El Heiz and Abu Minqar are convinced that the iron-rich drinking water is bad for them. Local residents complain about a particularly high incidence of kidney problems, particularly kidney stones. While this disease is often linked to unhealthy eating habits with too much protein and salt, there could be a link

between possible bacteria contamination in the water and the high incident of kidney problems in the area.

## **5. FINDING A SUSTAINABLE DRINKING WATER SOLUTION**

One of the biggest challenges with finding a suitable system for El Heiz and Abu Minqar was the remote location of the two oases. At distances of 400 and 650 km from Cairo, the constant adding of chlorine and a change of filters every 1-3 months, as required in a conventional system, are sustainability threats. These are not only monthly costs that need to be covered, but someone also has to go all the way to the next city, in this case Cairo, to purchase chlorine and new filters. Given that all conventional stations in El Heiz failed, also because of technical problems that could not be fixed by local technicians, it was important to find a system that would operate with a minimum requirement of maintenance. This led the project team to the implementation of a low energy, low maintenance solution designed specifically for remote communities. AUTARCON's SuMeWa system generates its own chlorine from the water itself, and uses greensand filters that can be flushed and recreate their own filter materials. The system is very easy to maintain and filters have to be changed every five to ten years only. The German company agreed to design a tailor made filter system that can cope with the extremely high iron content in the Western Desert's ground water. The system can run on solar energy, which was necessary in El Heiz, which only has five hours of electricity per day, and fits into a small box for easy transportation.

The systems were finally installed in the two communities in February 2014, after in both communities local residents had pooled money to build small station rooms with white brick. These rooms were equipped with a concrete base to place a three to five cubic meter input tank and a wooden roof. The project contributed the tiles for the room interior. In Abu Minqar, the station was installed with the help of the local development association and the local government office. In El Heiz, the elders from the village of Ain Gomaa, where the stations were placed, took ownership of and responsibility for the equipment installed. The pilot system installed in El Heiz was a solar energy operated system, while in Abu Minqar enough electricity was provided by the local generator (20 hours per day) to operate the system without the need for PV. The system in El Heiz, which used unfiltered water taken straight from the water well, had to deal with much higher iron levels of X mg per liter than those found in Abu Minqar, where the water was already pre-filtered by the existing filtration station. The high iron content in the water decreased the capacity of the station in El Heiz by almost 50%, which led the AUTARCON and RISE engineers to add a natural sand pre-filter system to the system in 2015. As Table 1 shows, both stations successfully removed the iron from the water with iron content decreased from over 5.5 mg per liter in El Heiz to less than 0.02. In Abu Minqar, the already treated water still contained 0.42 mg of iron, which was reduced to 0.03 g by SuMeWa. More importantly, the chlorine generated from the water itself enables communities to safely transport and store their water in containers and jerry cans without the growth of bacteria and other pathogens.

**Table 1:** Water analyses in El Heiz and Abu Minqar before and after water treatment  
**El Heiz (the category treated water refers to the RISE / AUTARCON station)**

	WHO guideline value	Source Water	Treated Water	
<b>pH</b>	6,5 – 8,5	6,76	7,02	
<b>Temperature</b>	--	25,8°C	24,0°C	
<b>Conductivity</b>	--	341 µS/cm	338 µS/cm	
<b>Iron</b>	max. 0,3 mg/L	<b>5,64 mg/L</b>	< 0,02 mg/L	
<b>Chloride</b>	0 – 250 mg/L	54,5 mg/L	52 mg/L	
<b>Chlorine</b>	> 0,5 mg/L	0	1,0 mg/L	
<b>Abu Minqar</b>				
	WHO guideline value	Source Water	Water Abu Minqar Treatment Station	Treated Water
<b>pH</b>	6,5 – 8,5	7,01	6,76	7,00
<b>Temperature</b>	--	39 °C	35 °C	23,0°C
<b>Conductivity</b>	--	189 µS/cm	294 µS/cm	295 µS/cm*
<b>Iron</b>	max. 0,3 mg/L	4,46 mg/L	<b>0,42 mg/L</b>	= 0,03 mg/L
<b>Manganese</b>	< 0,1 mg/L	0,22 mg/L	< 0,2 mg/L	
<b>Chloride</b>	0 – 250 mg/L	30,6 mg/L	30,6 mg/L	30,0 mg/L
<b>Chlorine</b>	> 0,5 mg/L	0	0	0,98 mg/L
<b>Sulfate</b>	250 mg/L	30,7 mg/L	--	--
<b>Hardness (CaCO<sub>3</sub>)</b>	--	35,4 mg/L	34,4 mg/L	33,4 mg/L

\* elevated value due to initial addition of NaCl into the water

## 6. OPERATING A DRINKING WATER STATION – A COMMUNITY CHALLENGE

The main challenges faced by the two communities in ensuring the long-term, sustainable operation of the system were technical challenges, dedicating time and effort to system maintenance and finding an appropriate pricing mechanism for the water. The pricing of water is a topic that has been widely discussed in academic literature, with scholars problematizing the commodification of this natural resource and the increasing reliance on (and failure of) neoliberal markets to bring about a fair distribution of water (Swyngedouw, 2009). In the context

of the Western Desert stations, the operation of the station was not intended to be a commercial operation, but a community service, the communities agreed that the operations simply had to cover the costs of operation and provide a financial cushion for future upkeep – no profits were sought. The challenge was to make water widely and equally available and accessible, while ensuring the financial sustainability of the stations and the ability of the communities to operate the stations on their own, through funding local operators. This trade-off inevitably and necessarily triggered local debates about social diversity, the economic well-being and spending capacity of households, local power dynamics and the physical and spatial access to water. It also embodied a test for communities on how far they were able to self-organize, and where they had to mobilize their networking social capital, a concept discussed by Adger (2003), by reaching out to the state to provide help through applying governmental structures.

In the two cases discussed here, the physical operation proved to be much less a dilemma of technical capacity than of social organization and dedication of time, both of which turned out to be closely intertwined with the financial operation of the stations. The stations in both communities were working flawlessly in a technical sense during their first year of operation. In each community, AUTARCON and RISE had trained two local residents in each community to operate and maintain the station. The maintenance tasks involved are fairly basic and straightforward. Cleaning efforts can be handled with a small tooth brush or toilet brush, and small errors are usually shown on the station's control screen and can usually be troubleshot with simple adjustments, such as emptying the tank or manually backwashing the filter. A red and green light on the control panel indicate whether the water is fit for consumption or not. Additional operational manuals in Arabic were hung up in both stations, providing the operators clear instructions on how to troubleshot a problem. After a year and a half of operation, the operators of both stations were quite able to troubleshot the few problems they encountered with the stations. Thus, the technical operation of the station was smooth. Regular visits by the researchers and feedback received from the operators in person and over the phone confirmed that technical problems were insignificant.

A much more serious issue were the financial management and daily operation of the stations. Although overall low maintenance and in rare need of spare parts, there are, of course, future maintenance costs to be anticipated for the installed stations. Even before installation began, the long-term financial sustainability of the stations was discussed with the community partners in both villages, given that the project did not entail any operational costs. It was clear that the users had to be charged for the water in one way or another, in order to pay for the station operators and for future spare parts. Initially, both communities decided to give residents free access for a few months, so that local residents would be convinced by the water quality before they were being asked to pay for the water. In both communities, it was anticipated that the station operators would eventually be present at the station according to advertised opening hours, two hours each evening, charging incoming users per jerry can of extracted water. The taps for water extraction were placed on the outside of the side wall of the station room in both communities. Although the station operators had been trained for this job, it quickly became clear that nobody

was willing to man the station on a daily basis. The operators stopped sticking to the announced opening hours and the stations' operation became unreliable. In Abu Minqar, a new petrol station opened shortly after the drinking water station had started its operations, leading the local station operator to take up a job there and to abandon the station only two months after having taken up his post. One problem had been that the local development association had never fully resolved the payment process for the operator and the young man thought that the income at the water station was unreliable. In El Heiz, a similar problem occurred. In the small and quiet community, local residents do not follow daily time plans and the concept of fixed opening hours was never particularly successful. The community resolved very quickly to letting the station operate all day long and to give local residents free access to water. In Abu Minqar, a member of the local development association who had been present at the time of installation and training took over the station management. Even though he was very capable of running the station, he was also not able to stick to certain opening hours, given that as a farmer and carpenter, he was involved in an array of daily responsibilities. When he traveled to another oasis for a week and the station remained closed, the local council demanded the key to the station and temporarily sent in another operator – which also failed. Before long, the station was operating freely, just like the one in El Heiz. The initial operational and financial plans had failed in both locations.

In both El Heiz and Abu Minqar discussions about possible options erupted. How could residents be asked to pay? A system wherein taps would only open after money had been inserted into a payment machine was too expensive to purchase at this stage. The monthly collection of money from all households that obtained water from the station was an option, but who would take charge of the collection process and the enforcement of payments? Moreover, what was an affordable price for a jerry can of water? Could there be a delivery system for water to the households that could operate as a small business and collect money by the jerry can? Even though this idea was raised in both communities, no local resident was willing to take up this task as an income generating activity.

The community of El Heiz thus decided to have their station operate based on donations. Very quickly, a local resident had installed a box on the inside of the station door with a slit in the plastic part of the door that users were able to feed money through. Only the station operators had the key to the box. After one year of operation, the community had collected a total of 1,500 EGP or around 190 USD. This money was then split in three parts – one third went to each station operator and the last third was saved to pay for future maintenance requirements. Although it was positive that money had been donated by the community throughout the year, the amount was not enough to cover the expenses needed to cover spare parts needed after ten years, as calculated by RISE and AUTARCON in a financial sustainability plan for the stations. Another challenge the community of El Heiz had to deal with is that investors from as much as 30 km down the road come to fill jerry cans of water for their farm. Despite their much bigger monetary capacity, these users are not donating more than members of the local community, which is not fair. The community has thus been discussing how these corporate users could possibly be billed separately.

In Abu Minqar, it was only after over one year of operation that a payment system could be established. This meant that after a year and a half of operation no money had been collected for the long-term maintenance of the station. Since its setup, the station has been struggling with individual cases of both theft and vandalism, committed usually during times when the station remained closed due to the absence of a station operator. Unknown community members repeatedly stole water taps from outside the station, and one of the stations' windows had been deliberately damaged with a rock. This was interpreted by local residents and the research team as a communication of frustration with a lack of public access and the ability to open and close the station resting with a selected few – in this case the station operator, the project team and the local government, who all had keys to the station. Also, various attempted payment schemes failed and the operators were worried to attach a donations box to the station door, given the theft cases that had occurred. In August 2015, the local government agreed to deal with running the station and manages the opening hours, manning the station every time it is open and collecting 0.5 EGP per jerry can (20 liters of water) from each user. Local people are worried, however, that the money collected by the local council may only cover the operation of the station, not the long-term maintenance.

## **7. COMMUNITY COHESION, SOCIAL CAPITAL AND THE VALUE OF WATER**

The two case studies of El Heiz and Abu Minqar show that changes in local waterscapes through technical innovation have significant impact on networks of social organization. Both communities were initially able to provide the finances and local labor for building the station rooms, thereby making an important social investment in the implementation of the system. However, as communities were later faced with the task to organize the long-term management and operation of the AUTARCON station, residents were forced to mobilize social capital based on existing structures of trust, reciprocity, community cohesion and the willingness to invest time and capital into the provision of a publicly available resource. The examples provided here show that responses and capacities vary between the two communities. Although financially less well-off than Abu Minqar, the community of Ain Gomaa in El Heiz showed a much greater ability to mobilize social capital in the operation and maintenance of the station. The station was seen as a public good shared by the families of Ain Gomaa, and thus did not experience any form of vandalism or deliberate damage. Despite the lower income the members of these extended families were willing to freely donate money for the long-term maintenance of their station. In Abu Minqar, in turn, the station was not as well-kept as in Ain Gomaa, experiencing several incidents of deliberate damage. Moreover, organizing a financial system that would work seemed more challenging in Abu Minqar than in El Heiz, and community members seemed less ready to pay for the service, despite their higher financial capacity. This lower degree of ability to mobilize social capital and to agree on a shared system of operation and maintenance may have to do with the social structure of Abu Minqar, being a planned oasis for settlers from varying background and a collection of villages with significantly different cultural habits and family ties and networks. Abu Minqar was not able to independently establish a functioning system until the

local government offered to take over the station's management – a solution welcomed by the local residents. The reduced ability to self-organize public services may be the result of Abu Minqar being a settler community established by the government, a community that has been relying on the government for the provision and improvement of local infrastructure and services since its very establishment. El Heiz, on the other hand, has relied for the self-organization of its villages based on extended families for centuries, with only sporadic infrastructural service improvements provided by the government.

The paper shows that a technical object, initially simply a “thing”, can function like a new actor in an existing social network – an actor that is given a particular importance and value by the local population and that in turn triggers specific social responses. The station as actor tests the communities' capacity for internal organization and the willingness and ability to mobilize social capital, both internal and networking capital (for example through calling in the local government for help). The new point of access to water transformed the local waterscape, and presented the population with a new dilemma: the question of how much each family would be able and willing to pay for the service of clean drinking water. Further, community members were forced to consider how much others would be able to pay and how this new technology could become an equally accessible natural resource. Pre-existing structures of village organization, expectations for service provision and levels of dependency on the government emerged as important aspects in the organizational process in the two communities. While it was easy to reach a consensus with the few heads of family in Ain Gomaa, the water station in Abu Minqar triggered debates about access and rights – the deliberate vandalism showing the frustration of some of being denied access to a shared natural resource.

## REFERENCES

- Adger, W.N., 2003:** Social Capital, Collective Action, and Adaptation to Climate Change, *Economic Geography*, 79(4), 387-404.
- Allam, M.N., 2004:** Participatory Irrigation Water Management in Egypt. In Hamdy, A., Tüzün, M., Lamaddalena, N., Todorovic, M., Bogliotti C. (eds.), 2004: *Participatory Water Saving Management and Water Cultural Heritage*. Options Méditerranéennes: Série B. Etudes et Recherches; n. 48, CIHEAM, Bari, 123-131.
- Burmil, S., 2003:** Landscape and Water in the Oases of Egypt's Western Desert, *Landscape Research*, 28(4), 427-440.
- Dahle, K., 1998:** Toward Governance for Future Generations: How Do We Change Course, *Futures*, 30(4), 277-292.
- Delemos, J.L., 2006:** Community-Based Participatory Research: Changing Scientific Practice from Research *on* Communities to Research *with* and *for* Communities, *Local Environment*, 11(3), 329-338.



- Freeman, C., Nairn, K. and Sligo, J., 2003:** 'Professionalizing' Participation: From Rhetoric to Practice, *Children's Geographies*, 1(1), 53-70.
- Harding-King, 1913:** The Farafra Depression and Bu Munqar Hattia, *The Geographical Journal*, 42(5), 455-461.
- Hosny, O., 2014:** *Personal Communication*. El Heiz.
- Loftus, A., 2009:** Rethinking Political Ecologies of Water, *Third World Quarterly*, 30(5), 953-968.
- Matarawy, G., 2014:** *Personal Communication*. El Heiz.
- Molle, F., Mollinga, P.P, and Wester, P., 2009:** Hydraulic Bureaucracies and the Hydraulic Mission: Flows of Water, Flows of Power, *Water Alternatives*, 2(3), 328-349.
- Mohan, G., 2006:** Beyond Participation: Strategies for Deeper Empowerment. In Cooke, B. and Kothari, U (eds.): *Participation: The New Tyranny?* London: Zed Books,153–167.
- Pain, R. and Francis, P., 2003:** Reflections on Participatory Research, *Area*, 35(1), 46-54.
- Putnam, R.D., 2000:** *Bowling Alone: The Collapse and Revival of American Community*. Simon and Schuster, New York.
- Soltan, M.E., 1999:** Evaluations of Ground Water Quality in Dakhla Oasis, *Environmental Monitoring and Assessment*, 57, 157-168.
- Sultana, F., 2013:** Water, Technology and Development: Transformations of Development Technonatures in Changing Waterscapes, *Environment and Planning D: Society and Space*, 31, 337-353.
- Swyngedouw, E., 2009:** The Political Economy and Political Ecology of the Hydro-Social Cycle, *Journal of Contemporary Water Research and Education*, 142, 56-60.
- Um Magdy, 2009:** *Personal Communication*. Abu Minqar.
- United Nations (UN), 1992:** Agenda 21. Rio de Janeiro, Brazil.
- United Nations (UN), 2015:** *The Millennium Development Goals Report*. New York. Accessed from [http://www.un.org/millenniumgoals/2015\\_MDG\\_Report/pdf/MDG%202015%20rev%20\(July%201\).pdf](http://www.un.org/millenniumgoals/2015_MDG_Report/pdf/MDG%202015%20rev%20(July%201).pdf) (9 December 2015).
- United Nations, (UN), 2016:** *We Can End Poverty*. Accessed from <http://www.un.org/millenniumgoals/> (9 December 2015).
- Water Research Center, 2014:** <http://www.water-research.net/index.php/standards/secondary-standards>
- World Health Organization (WHO), 2004:** *Guidelines for Drinking Water Quality*. World Health Organization, Geneva.

# Small Scale Solar Energy Projects for Local Income Generation in the Oases of Egypt's Western Desert – A Field Report

Martina Jaskolski  
Research Institute for a Sustainable Environment  
The American University in Cairo  
[tinajas@aucegypt.edu](mailto:tinajas@aucegypt.edu)

## ABSTRACT

This paper is the story of a solar energy project implemented in the Egyptian desert oasis of Abu Minqar in early 2010. The project, set out as a local income generation project targeting women in particular, how a project that was initially viewed as a failure could be turned into a successful small business initiative that now generates employment for women in an oasis in the heart of Egypt's Western Desert.

## 1. PAVING THE WAY FOR HOUSEHOLD SOLAR POWER IN THE DESERT

Abu Minqar is a new oasis located 650 km southwest of Cairo in the heart of Egypt's Western Desert. Home to around 4,000 people who are spread across six communities (Farafra Information Center, 2014), Abu Minqar is entirely the result of Egypt's desert reclamation and resettlement efforts, which have been a part of Egyptian national policy since the 1950s in an effort to relieve the Nile Valley and Delta of population and generate investment and economic growth in the country's desert areas (Sims, 2015). Before the 1980s, the oasis was not more than a place where Bedouins would stop with their camels on their routes across the desert – there was one natural spring in Abu Minqar, the so-called Roman Spring, which had served travelers as a source of Water, but which ran dry decades ago. After large scale hydrological analyses had shown vast amounts of water stored in the layers of sandstone rock known as the Nubian Sandstone Aquifer, which runs beneath Egypt, Libya, Chad and Sudan, the government had singled out the former watering hole as an area for agricultural expansion and settlement. After a government owned agricultural company had initially prepared the land for agricultural production, the government prepared wells, field and built houses for desert settlers to come, live and farm in Abu Minqar starting in 1985. While the first wave of settlers came from Dakhla under the so-called beneficiaries program for people whose families did not own enough land to survive, other waves of settlers soon followed, with the last wave of government sponsored settlers arriving in 1999 to settle the village of Talaat Dargham under Egypt's graduate program (Farafra Information Center, 2014) – a program that grants graduates from state universities an existence as desert farmers for a lack of promised work possibilities with government agencies (Voll, 1980). The new farmers of Abu Minqar were given six feddan (roughly six acres) of land and a house, which they had to pay in rates over the course of twenty years. Despite years of hard struggle farmers went through in order to make the oasis an inhabitable place and a place to farm, the oasis is now growing – even though many of Abu Minqar's farmers are not the initial

graduates who applied for the settlement program. It is especially among the initial wave of settlers from Dakhla that farmers now call Abu Minqar home.

Abu Minqar is an agricultural community. All families in Abu Minqar own land and cultivate land for both subsistence and income generation. Interestingly, Abu Minqar's farmers practice open a type of field cultivation of wheat, fava bean, maize and vegetables that is more in line with what is practiced in the Nile Valley and Delta – rather than the oasis agriculture focused on date production that can be found in the old oases of Bahariya and Farafra. Since 2006, when the researcher first started to conduct field research in the oasis, livelihoods in Abu Minqar are both improving and diversifying. Although income opportunities outside agriculture are rare, the farmers of Abu Minqar are constantly seeking additional sources of income – through offering services as carpenters, in construction or as electricians, by opening corner shops, or by buying small trucks and taking on transportation and trading jobs. An increase in local incomes is reflected in the growing investment in houses, for example, and many of the original settler families have built at least one new house since their move to the new desert oasis. However, although the income generation of Abu Minqar's men expand, local women have much less opportunities to pursue income generating activities especially outside the home. On the one hand, women's work is stigmatized by both men and women and women having the luxury to stay at home is seen as a family privilege, a class phenomenon observed in many parts of the Middle East (Toth, 1991). On the other hand, opportunities for paid labor for women in Abu Minqar are rare and limited to work in shops, at schools or at the pharmacies – all activities restricted to unmarried women. Abu Minqar's women do help out in agricultural labor, especially in activities that require less physical force, such as harvesting. Most women also tend to the care of animals, especially smaller animals such as poultry or ruminants that are kept within the confines of the house complex of the extended family, and might milk cows kept near the house. Wherever animals are kept further away from the house, in the case of Abu Minqar specifically in a separate section of the main village, this task is being taken over by men.

## **2. SOLAR ENERGY AS A SMALL-SCALE INCOME GENERATOR**

This paper is introducing a small scale sustainability project aimed at generating income for young people in Abu Minqar, particularly women, by using solar energy. However, at its onset, the project was not conceived as such, but instead as a straightforward measure to generate electricity – also specifically benefiting local women. Abu Minqar is not connected to Egypt's national electricity grid, which ends in the oasis of Bahariya, 300 km north of Abu Minqar, and in the oasis of Dakhla, 200 km southwest of Abu Minqar. Both Farafra and Abu Minqar rely entirely on diesel operated generators in order to provide electricity for local homes. At the beginning of this project in 2011, Abu Minqar had access to around 6 hours of electricity per day, starting at dawn and finishing at around 1 am. At this time, the lack of constant electricity was one of the most frequent complaints local residents would voice when asked about development issues in their oasis. The limited electricity supply would not only mean that houses could not operate lights and electronic equipment such as fans, fridges or washing machines

throughout the entire day, but also that local businesses could not operate any electric equipment during the part of the day usually conceived of as ‘working hours’. In this way, the lack of electricity would stifle local economic opportunities, while also increasing the hardships of local life, especially during the summer months, when particularly women and old people would complain about unbearable heat inside their homes.

In order to improve the electricity supply for Abu Minqar’s residents, the Research Institute for a Sustainable Environment (RISE), in 2010 still called the Desert Development Center or DDC, applied for funding from the Canada Fund in Cairo. Together with the donor, the RISE research team agreed to implement a test project for local electricity provision. The idea was to start a battery supply and charging service run by the local project partner, the Development Association of Abu Minqar, for households from the village. The service would entail a 200 watt solar system, mounted on the roof of a charging station, with two 80 amp 12 volt batteries, an inverter and a controller in the control room. RISE decided to use panels that were left over from a research project implemented in the early 1980s. The panels that had been left sitting around were successfully reactivated and functioned at 80% capacity after almost 30 years. Initially, four truck-sized batteries that people could carry back to their homes to run simple appliances such as a fan, a television, or a computer. The idea was to run this project as a pilot, and that the battery station could soon be up-scaled to include a larger number of batteries (even used truck batteries that can be made available at very low cost). The charging station itself would be operated by a group of women from the local association, and users would be paying a few Egyptian pounds, less than 1 USD, per charge. The Canada Fund enabled the initial project kick-off and its pilot phase. After discussions with the local association, RISE purchased the PV system and four test batteries that were supposed to be used in a test phase for the project. The local association decided to install the PV system in front of the house of the association’s elected president, with controller, inverter and battery charging system located in a room right at the entrance to the house (Figures 1-3).



**Figures 1-3:** Installation of the solar system in Abu Minqar. RISE decided to recycle 30 year old panels for this project that were still working at 70 percent capacity.

### **3. CREATING INCOME OPPORTUNITIES FOR WOMEN**

The project was conceptualized as part rural electrification project, part income generation opportunity for local women. In a meeting with the local development association of Abu Minqar, it was decided that a group of local women, including several women from the extended household where the charging unit was located, as well as a number of women whose husbands were members of the association, would manage the unit. Interestingly, women were not present at this community meeting, as public meetings such as the meetings of the development association are seen as a man's task in the community. However, the field team separately approached a number of women on the subject, and the men represented at the meeting discussed the charging unit plan with their wives. The financial plan was that, if each battery was recharged once a day, the unit would generate about 20 EGP every other day (as recharging the batteries would take a day), of which ten pounds would be kept by the development association to save up money for future system maintenance, and ten would be divided among the women involved in the project. The project plan entailed that the number of batteries could quickly be doubled, so that batteries could be charged every day. Manning the charging station was not seen as a full-time job, and women agreed that there could be fixed drop off and pick up times for the batteries, such as dropping off the batteries in the morning and picking the up at the end of the day for use during the following day. Meanwhile, other batteries would be charging at the station for other users. In this concept, women were not only anticipated to be the ones running the charging station, but also the ones handling, connecting and disconnecting the batteries. Having all stages of the project run by women was also necessary for cultural reasons, as the women delivering batteries to a charging station run by other women was seen as more socially acceptable than women entering a charging station run by local men, located in a private house. Following the agreement to this general plan, a representative of the solar company who installed the system ran a technical training for the local women (Figures 4 and 5), which entailed training on the running and maintenance of all charging unit components, as well as a practical training on how to connect, disconnect and transport the batteries. Although fairly heavy, women decided that they were able to carry the battery to the charging station - if need be with the help of donkey carts.



**Figures 4 and 5:** Planning meetings with representatives of the development association, including the mayor (left) and solar training for local women (right).

In February 2010, the project entered its pilot phase. One of the project's goals was to test the feasibility of this battery charging service locally, and to assess the power of the batteries, to measure the amount of time women would be able to operate certain household appliances during the day, and to evaluate the overall performance of the project idea in helping local households bridge the hours of the day without electricity. In order to start the pilot project, RISE designed a research protocol that local women were instructed to follow. Each woman who would pick up a battery would fill in a simple questionnaire at the end of the day to report on the types of appliances operated on the battery, the hours of operation, the general battery performance and any other comments, for example on difficulties experienced while connecting, disconnecting or transporting the battery. All involved women agreed to the plan, after the questionnaire had been discussed with all involved women individually at their homes by a female researcher. On top of this, a local research assistant was appointed, a young woman who helped out her parents operate a mobile phone accessory shop at night, to follow up on the questionnaire and to make sure the women would fill in all required fields. Also, the women were told to approach the research assistant with any problems they may encounter with the trial. On top of the questionnaire, the research team developed a clear distribution roster by which the women were to take out the solar batteries throughout the first three months of the project. This should ensure that all participating women had the chance of testing and reporting on the system.

The pilot project failed for several reasons. The first reason was a mix of curiosity and gender inequalities. As soon as the research trial had been set up and the RISE team had left the village, several men showed increased interest in the novelty of the battery scheme. They took the batteries home and thus disrupted the flow of the research plan as early as day two. When RISE followed up on the research progress with the local research assistant a few days later, it became clear that three out of four batteries had gone missing pretty much from the first day of the trial. One battery had allegedly been picked up by the local mayor in order to test the battery at his

house. Two other batteries had been taken out of the hand of local women by their husbands to perform their own tests on them. The women were thus not able to keep control of the batteries and test their performance according to plan. It seems that, despite their vocal agreement to the plan that women would be running the project, the local perception that technical equipment was best placed in the hands of men, had ruined the trial process. While RISE had soon given up on any research progress according to the set up plan, news about the performance of the batteries had soon gone from bad to worse. As the team was initially told by phone, and in more detail during the next field visit, the batteries were not meeting local expectations. As several residents explained, the batteries were not able to power enough appliances for a long enough time that would make it worthwhile paying for the recharge. Additionally, both local men and women had soon become fed up with carrying the batteries around the village for recharge. The feedback the team received was that, despite the desperation for electricity during the day, the effort was simply too big for something that was seen as “no real electricity anyway”. Although it had previously been discussed with all participants that the capacity of the batteries was limited, it seems that the local residents were generally disappointed with their performance.

#### **4. TURNING A PROJECT FAILURE AROUND**

One lesson learned from this failed local project was that ideas for including women in the local workforce may sound promising in theory, and may actually be agreed upon by community members, but may still fail in actual practice. The project team had carried out both research and development projects in Abu Minqar since 2006, for over five years before the solar battery project began, and were quite familiar with local cultural and social customs. Despite this knowledge, one reason for the project failure was a different understanding of gender and technical on the sides of the project team and the local association. This difference did not become clear until the project was actually in operation. Although it had seemed appropriate that the women, who spend a lot of their time in the household, would manage and test the batteries at their homes, this link did not sit well with local customs. Despite the training, local men were not under the impression that women would do a good job with the technical equipment, and stepped in from day one. Subsequent discussion with the development association of Abu Minqar about how the project should now proceed led to an entirely new idea. One local farmer raised the idea of using the existing solar system and batteries to power a chicken incubator system that could be run by a member of the association, and in the operation of which women could play a significant role. Most of the RISE researchers had never heard of such a machine, but promised into the technical feasibility of this idea.

It turned out the idea to turn the dysfunctional battery charging station into a chicken incubator system turned the project failure into a success. RISE had researched that a chicken incubator for 200 eggs was available for around 200 USD in Egypt at the time, and that the existing system could easily be modified to power the system. The chicken incubator is a machine that eggs are placed into and rest on trays a total of 21 days. The trays are switched around several times

throughout this period, and the eggs are put into a hatching tray at the very end of the period. The success rate of chicken incubators is much higher than that of naturally breeding chickens. In order to guarantee a constant temperature of 38 degrees for the eggs, the chicken incubator needs constant and stable electricity – something that did not exist in Abu Minqar at the time. Thus, the solar system seemed like a perfect way of enabling such a business idea. The association quickly decided which extended family should be taking care of this business and agreed that X percent of the income should be shared with the association. RISE helped with the de-installation of the existing system and the re-installation in the house of the local electrician – who quickly perfected the system through a number of extra gadgets, such as an automatic switch, that would switch to village electricity during the hours the local generator was operating. Less than a week later, the chicken incubator was functioning. The operating family decided that users would be paying an Egyptian pound per egg, in case the egg would hatch. What's the failure rate? With a capacity of 200 eggs, this would mean 200 EGP for the family every 21 days. It was the extended family's women, who also tend to an array of poultry in the courtyard behind the house, adjacent to the chicken incubator, who organized the egg collection and tended to the eggs. According to local women, there was an incredible demand for the incubator. Local women were literally queuing up to get a spot in the incubator, each woman writing her name on her egg so that the chickens could be identified at the end of the hatching process. As an association member recounted, a place in the incubator had become a new dimension of the Egyptian *wasta* system – an exchange of one favor for another and the mutual owing of social support and favors. After only a few months in operation, there were requests for more incubators, and with additional funds, RISE was able to buy an additional two incubators for 200 eggs, and to eventually increase the capacity of the solar system and allow for a larger incubator, fitting 1,000 eggs. Two incubators fitting 200 eggs were given to an operator in another village of the oasis, thereby expanding the service across the village. The second operator recounted similarly high demand to the first one: “My wife is starting to have serious family issues because of this incubator. Her cousins and aunts and nieces all ask her for a family favor to accept her eggs, and sometimes there is simply no place, so what can she tell them?”

## **5. LESSONS LEARNED**

The first attempt to generate household electricity and establish an income generation opportunity, particularly for local women, failed due to several factors: the system being impractical, the solution not generating as much as electricity for households as local residents had hoped, and prevailing gender roles and stereotypes in the village. This project experience showed that even technical solutions that seem theoretically feasible and are initially embraced by the local population, fail due to local social and cultural structures, differences in expectations, or practical inefficiencies that limit the user friendliness of a technical solution. The assessment of a similar solar energy project implemented in a Spanish village brought close to zero income generation for the local population, in this case because it was not integrated well into the existing local economic structure of the village and was not sufficiently linked in



with the local production system (del Rio and Burguillo, 2009). In the case of the Abu Minqar project, it turned out that the chicken incubator solution fit in much better with local economic needs and expectations, eventually generating more income for local women than the household battery charging station.

With the help of local residents, RISE is looking into further expanding the local chicken incubator businesses locally. Since its installation, the operator of the first system, the operator of the first system has already made considerable personal investment into the improvement of the system, showing that the business is starting to be self-sustainable. The only significant problems that occurred was a broken inverter, which RISE helped fix, and the fact that during the summer months the air temperature outside the incubator is actually higher than the temperature inside – causing the system to malfunction for the three hottest months of the year. In the first system, the batteries have been changed once since 2010, and batteries installed in 2012 are already showing some charging deficiencies. According to a German expert who visited the project, this problem is due to the fact that the type of batteries installed at the time were batteries designed for the communication and mobile phone industry, for example for transmission towers that receive small signals every now and then and are thus not recharged on a daily basis (Goldmaier, 2014, pers. comm.). Through operating the system for several years, the owner of the first system has gained significant capacity in solar energy systems' maintenance and troubleshooting, and is assisting the operator of the newer system in the oasis's second village. Thus, a horizontal transfer of know-how is already happening in the village. RISE is currently applying for funding to improve and expand the existing systems, and to help other local residents start new systems.

In assessing the mechanisms at play here that turned the project into success or failure, it becomes obvious that there are a number of different issues at stake. Although the initial system was universally conceived of as a good idea and worthwhile trial to at least partly solve Abu Minqar's electricity problem, it became clear that the batteries were neither powerful nor user friendly enough to make the involved effort of using a local charging station worth its while. Since the time of the project, Abu Minqar's village electricity supply has been increased to 20 hours per day, which solves many of the problems that prevailed in 2010. The chicken incubator systems, however, are still in need of the solar units, or at least of a hybrid system. Gender issues also clearly played into the project failure. Both the battery charging and operation as well as the chicken incubator system are essentially home based and located in what is locally seen as mostly the private sphere. Thus, it seemed that both projects would be culturally accepted, especially after local men had confirmed their support at the onset of the project. As it turned out, however, the technical aspects of the battery charging project were perceived of as "not female tasks", which is why men quickly hijacked the batteries. The fact that the batteries in the first project were moveable also enabled more people to interfere with the project's success than in the case of the chicken incubator system, which is firmly installed in one place. Although women manage the collection of eggs and supervise the breeding process, even in the chicken incubator case local men are taking care of the technical maintenance of the system – thus again placing technical tasks firmly into the hands of men. Overall, the chicken incubation system also

seems economically more successful than the battery charging system would have been, at least during its initial phase. Both the local association and the female operators benefit from the egg incubators' financial success. Nevertheless, women rarely get to physically keep the money for themselves or take active decisions about how the money is spent. The benefit here is an indirect one, there is more money to be spent on the household and children.

## REFERENCES

**del Rio, P., Burguillo, M., 2009:** An empirical analysis of the impact of renewable energy deployment on local sustainability. *Renewable and Sustainable Energy Reviews*, 13 (6-7), 1314-1325.

**Farafra Information Center, 2014:** *List of Residents of Farafra and Abu Minqar*. Computer File Obtained from the Local Council.

**Goldmaier, 2014:** *Personal Communication*. Abu Minqar.

**Toth, J., 1991:** Pride, purdah or paychecks: what maintains the gender division of labor in rural Egypt? *International Journal of Middle East Studies*, 23(2) 213-226.

**The Conference – Some Impressions**



**The Conference Excursion – Some Impressions**

