



الفراغات التمهيديّة للمباني الثقافية

(دراسة تحليلية لأسس التصميم)

بحث مقدم لقسم الهندسة المعمارية
كجزء من متطلبات نيل درجة الماجستير في الهندسة المعمارية

مقدم من
المهندس/ محمد علي محمد خليل
المعيد بقسم الهندسة المعمارية - كلية الهندسة - جامعة المنصورة

إشراف
أ.م.د. / أسامة محمد علي فرج / **أ.م.د. / محمد محمد طه العزب**
أستاذ العمارة المساعد- قسم الهندسة المعمارية / أستاذ العمارة المساعد- قسم الهندسة المعمارية
كلية الهندسة- جامعة المنصورة / كلية الهندسة- جامعة المنصورة

بِسْمِ
الرَّحْمَنِ الرَّحِيمِ

الْحَمْدُ لِلَّهِ الَّذِي هَدَانَا
لِأَنْفُسِنَا وَمَا كُنَّا لِنُفْتِكِرَ
لَوْ لَا أَنْ هَدَانَا اللَّهُ

صدق الله العظيم

() .

()

:

.

:

:

	- -	/...
	- -	/...

()

:

.

:

:

	- - -	/...
	- - -	/...

:

	- - -	/..
	- - -	/..
	- - -	/...
	- - -	/...

شكر وتقدير

..... / :
..... - -
..... / :
..... - -
..... - /
..... -

البحث

الفصل

.

المبحث

قائمة المحتويات.

مقدمة البحث.	مقدمة
انفراغات التمهيدية للمباني الثقافية (المفهوم والمحددات).	الفصل الأول
تطور الفكر التصميمي للانفراغات التمهيدية حتى بدايات القرن	الفصل الثاني
الفكر التصميمي للانفراغات التمهيدية اوآخر القرن العشرين.	الفصل الثالث
عوامل خاصة بالمكون المادي للفراغ التمهيدي.	الفصل الرابع
عوامل خاصة بالاستخدام كمكون إنساني للفراغ التمهيدي.	الفصل الخامس
نماذج ريادية لتأثير عوامل التصميم علي نجاح الانفراغات التمهيدية للمباني	الفصل السادس
النتائج والتوصيات.	الفصل السابع

الانفراغات التمهيدية للمباني الثقافية

قائمة الأشكال.

مقدمة البحث.

الفراغات التمهيدية للمباني الثقافية (المفهوم والمحددات).

تطور الفكر التصميمي للفراغات التمهيدية حتى بدايات القرن

الفكر التصميمي للفراغات التمهيدية أواخر القرن العشرين.

عوامل خاصة بالكون المادي للفراغ التمهيدي.

عوامل خاصة بالمستخدم ككون إنساني للفراغ التمهيدي.

نماذج ريادية لتأثير عوامل التصميم علي نجاح الفراغات التمهيدية للمباني

النتائج والتوصيات.

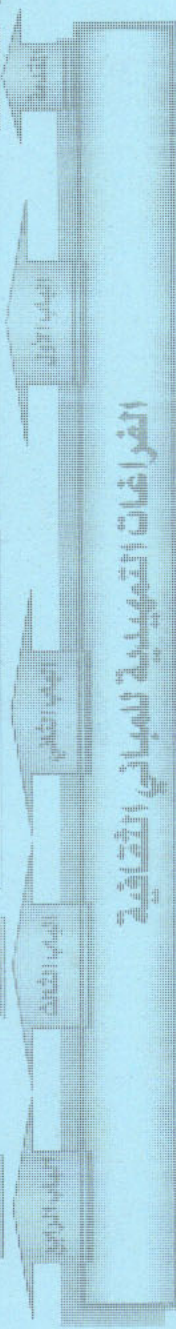

.....	(-)
.....	(-)
..... (Karlsruhe)	(-)
.....	(-)
..... -	(-)
.....	(-)
.....	(-)
.....	(-)
.....	(-)
.....	(-)
.....	(-)
.....	(-)

..... : - -

.....	(-)
.....	(-)

..... : -

..... : - -

.....	(-)
.....	(-)
.....	(-)
.....	(-)
.....	(-)
.....	(-)
.....	(-)
.....	(-)
.....	(-)
.....	(-)
.....	(-)
.....	(-)
.....	(-)
.....	(-)
.....	(-)
.....	(-)

.....	(-)
.....	(-)
.....	(-)
.....	(-)
.....	(-)
.....	(-)
.....	(-)
.....	(-)
.....	(-)
.....	(-)
.....	(-)
.....	(-)
.....	(-)
.....	(-)
.....	(-)
.....	(-)

..... : - -

.....	(-)
.....	(-)
.....	(-)
.....	(-)
.....	(-)
.....	(-)
.....	(-)
.....	(-)
.....	(-)
.....	(-)
.....	(-)
.....	(-)
.....	(-)
.....	(-)
.....	(-)

..... : -

..... (-)

()

.....

(-)

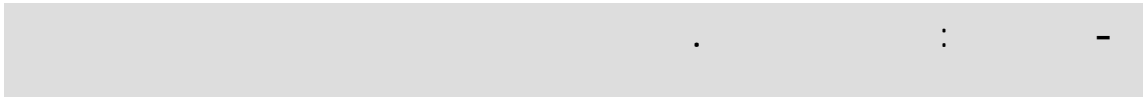

.....

(-)

.....

(-)

قائمة الجداول.

مقدمة البحث.	المقدمة
الفراغات التمهيدية للمباني الثقافية (المفهوم والمحددات).	الفصل الأول
تطور الفكر التصميمي للفراغات التمهيدية حتى بدايات القرن	الفصل الثاني
الفكر التصميمي للفراغات التمهيدية أواخر القرن العشرين.	الفصل الثالث
عوامل خاصة بالكون المادي للفراغ التمهيدي.	الفصل الرابع
عوامل خاصة بالاستخدم كمكون إنساني للفراغ التمهيدي.	الفصل الخامس
نماذج ريادية لتأثير عوامل التصميم علي نجاح الفراغات التمهيدية للمباني	الفصل الثالث
النتائج والتوصيات	الفصل الرابع

الفراغات التمهيدية للمباني الثقافية

..... : -

- (-)
- .. (-)
- (-)
- (-)

..... : -

- (-)
- (-)
- - (Centre Pompidou) (-)
- (-)
- _ (Louvre Pyramid) (-)
- (-)
- - (Plase Des Terroux) (-)
- (-)
- _ () (-)
- (-)
- - (Nubian Museum) (-)
- (-)
- .. _ (Bibliotheca Alexandrina) (-)
- (-)
- (-)

..... : -

- (-)
- (-)
- (-)
- (-)
- (-)
- (-)

مقدمة البحث.

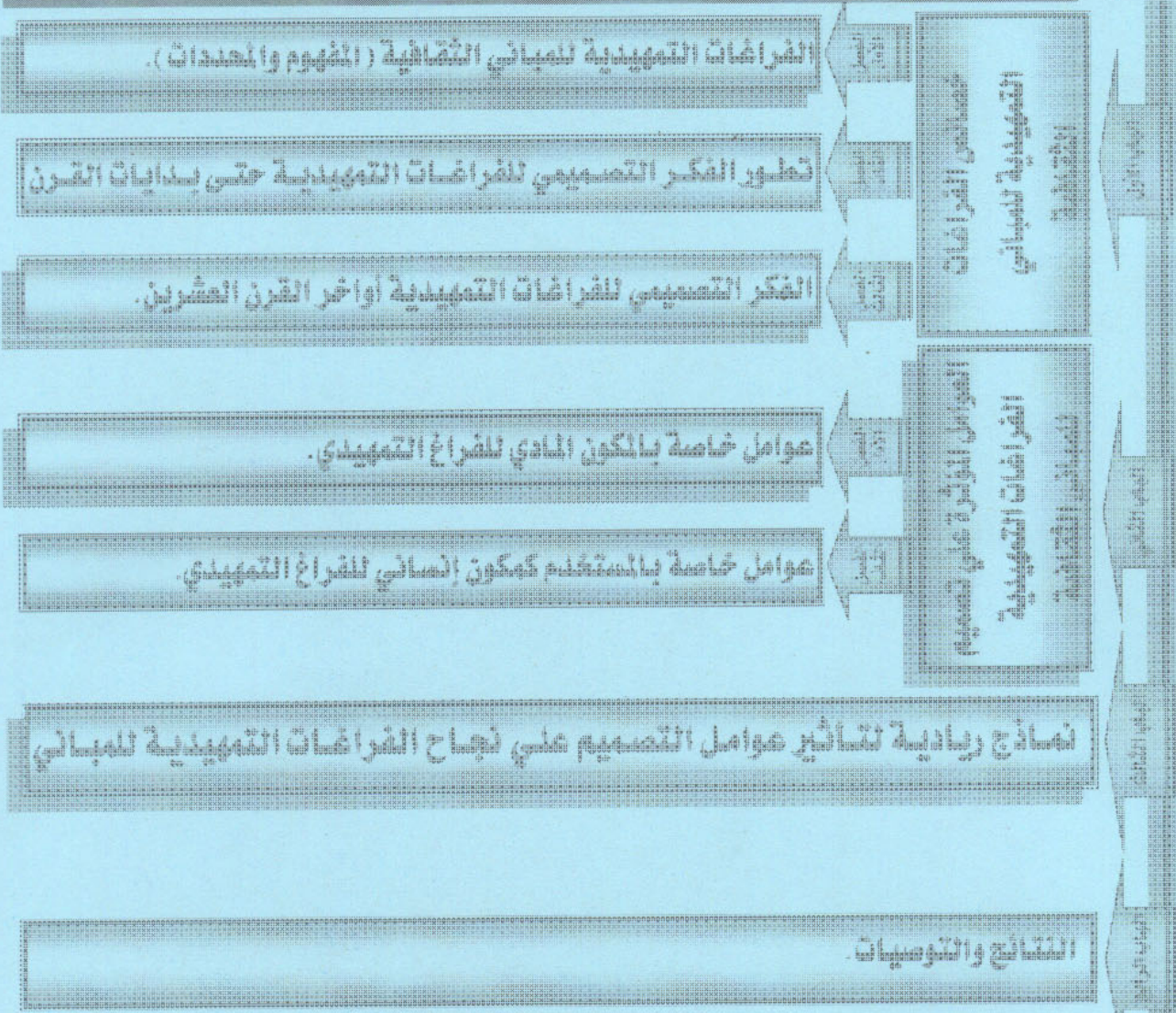

_____:

- -

-

-

.

-

-

" "

"

"

" "

1

2

³ جيهان، سليم، "تأثير تيار العولمة على الثقافة والهوية المصرية المعاصرة"، رسالة ماجستير، كلية الهندسة، جامعة القاهرة، ٢٠٠٠.

()

"

"

"

"

⁴ أشرف بطرس "مرجع سابق"

⁵

⁶

- -

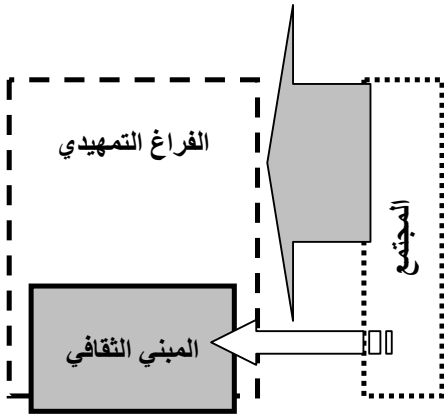



-

()

) _____

_____ (

- - _____

○

○

○

○

()

_____ :

:

_____ :

_____ .

:

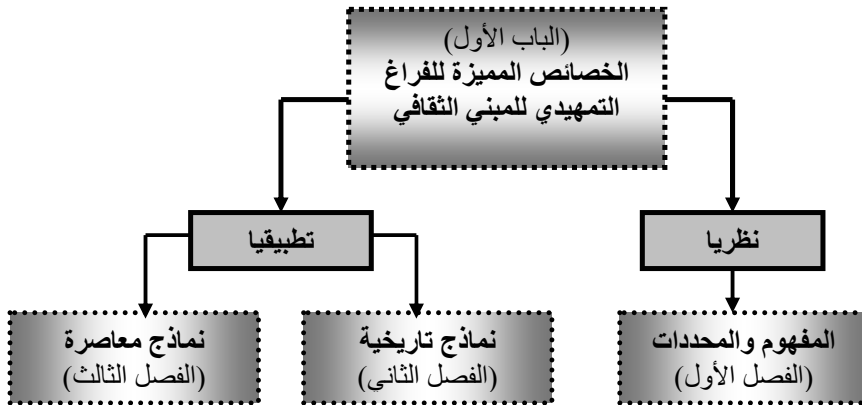

:

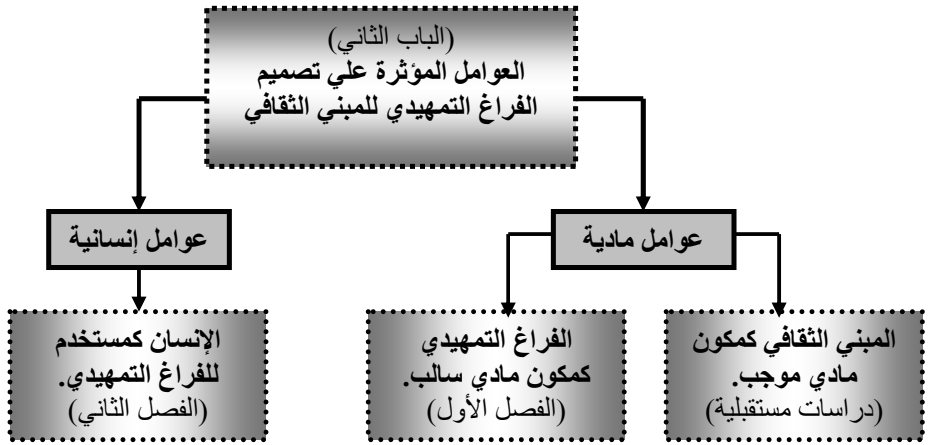

:

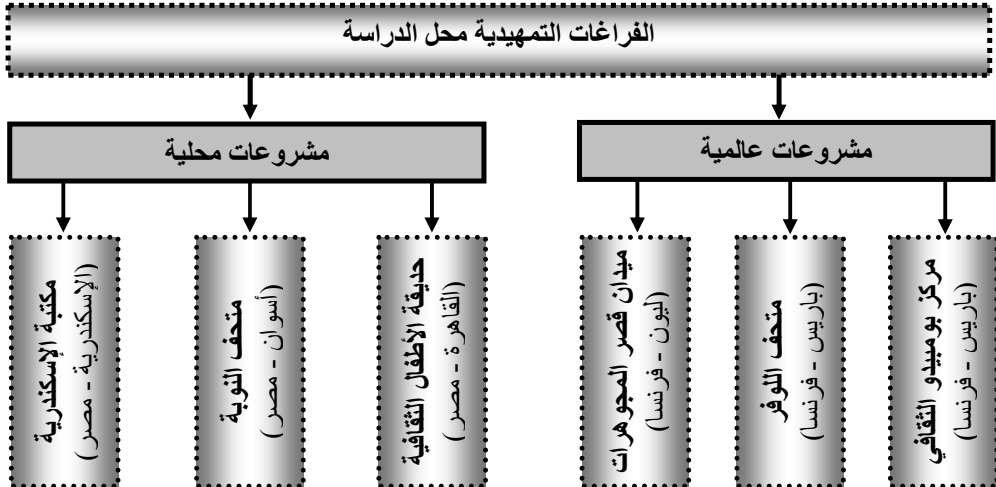

:

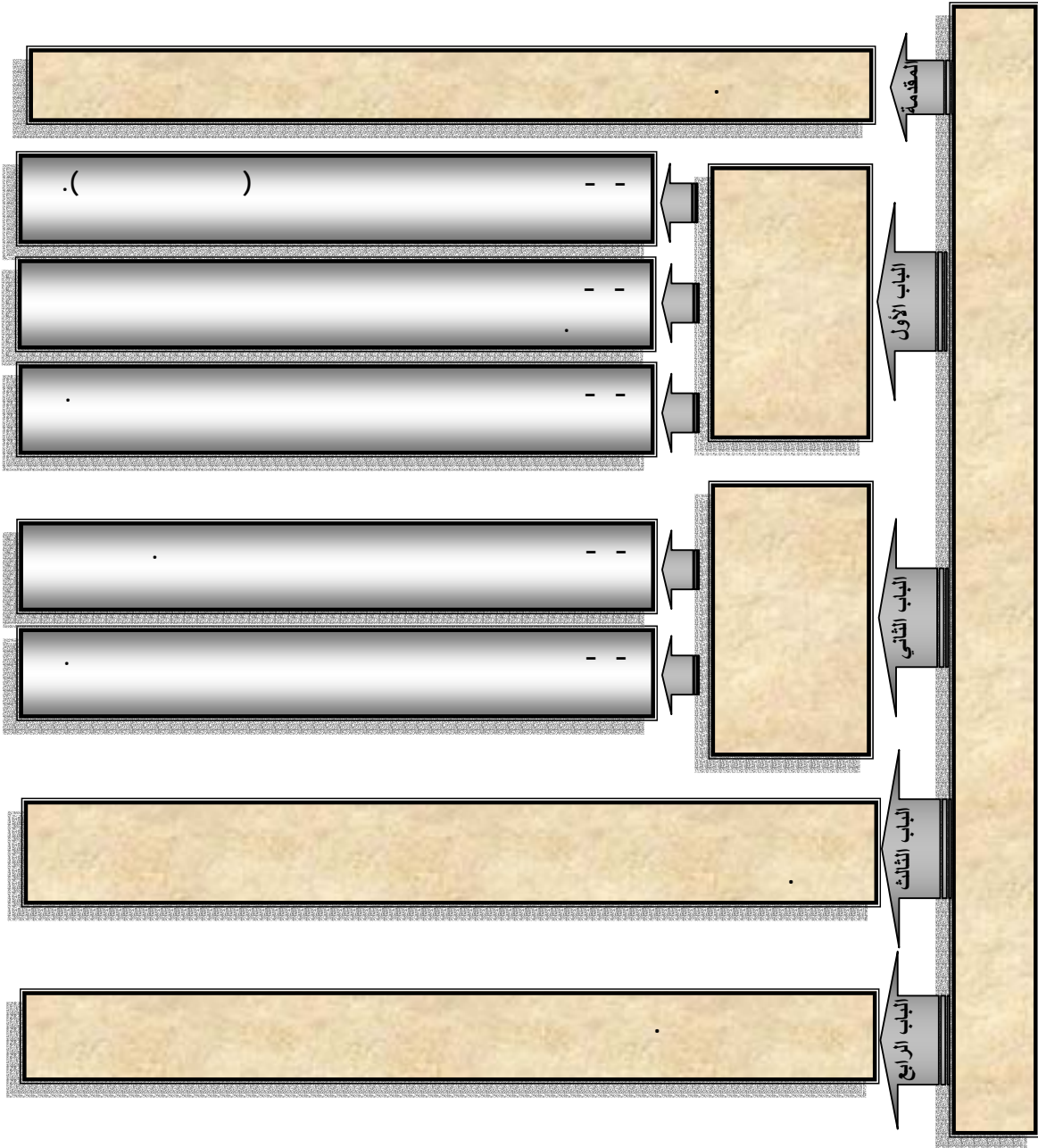

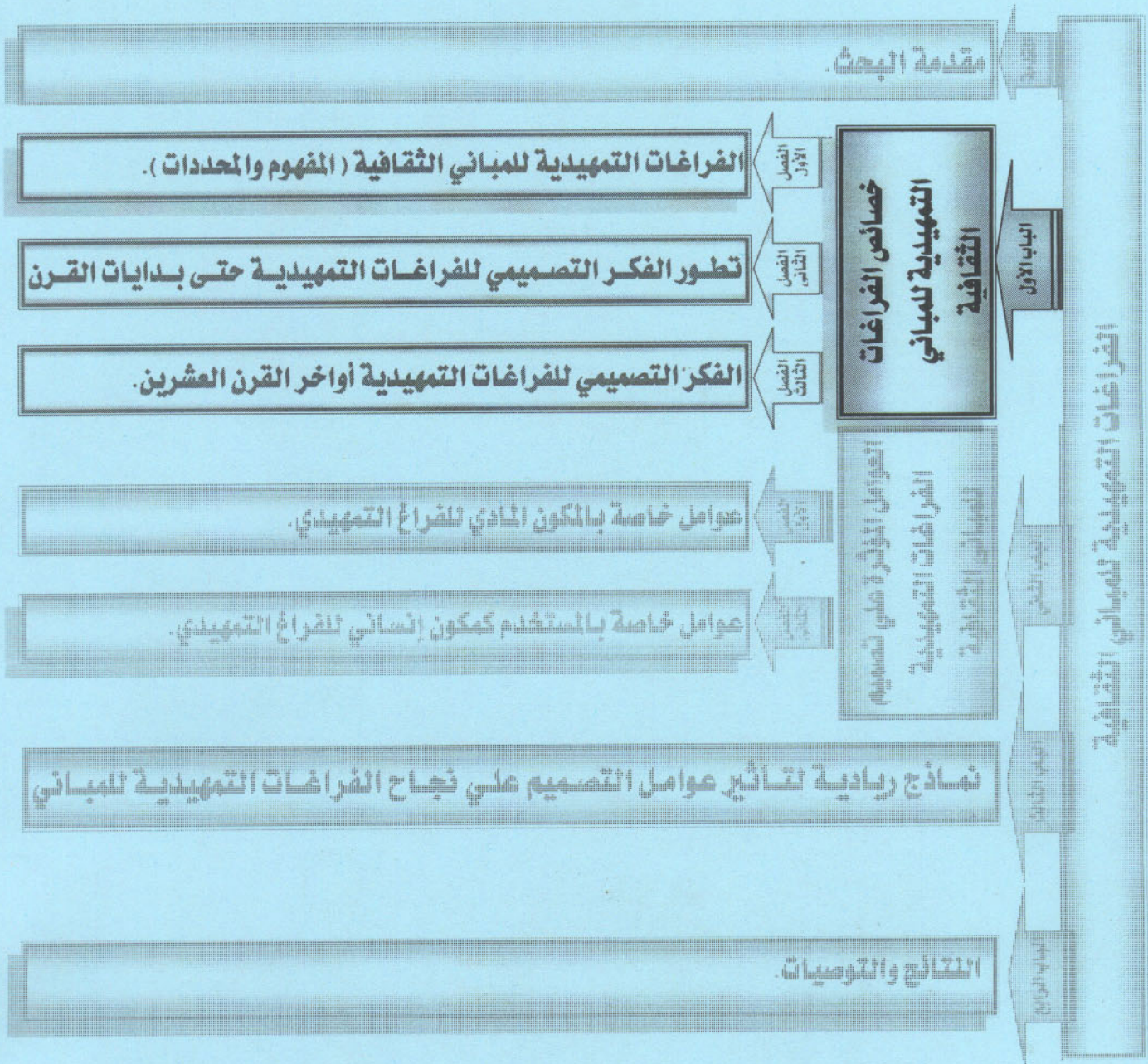

الباب الأول: ويمثل الخلفية النظرية ويهدف للوصول إلي الخصائص المميزة للفراغات التمهيدية للمباني الثقافية وذلك من خلال ثلاث فصول:

الفصل الأول يتناول دراسة مفهوم الفراغات التمهيدية للمباني الثقافية وتصنيفها ومحدداتها.

الفصل الثاني يتناول تطور خصائص الفراغات التمهيدية في العصور المختلفة وحتى الوصول إلي أوائل القرن العشرين.

الفصل الثالث فيتناول خصائص الفراغات التمهيدية للمباني الثقافية منذ أواخر القرن العشرين وحتى الوقت الراهن.

()

()

:

-

- -

.

.

.

.

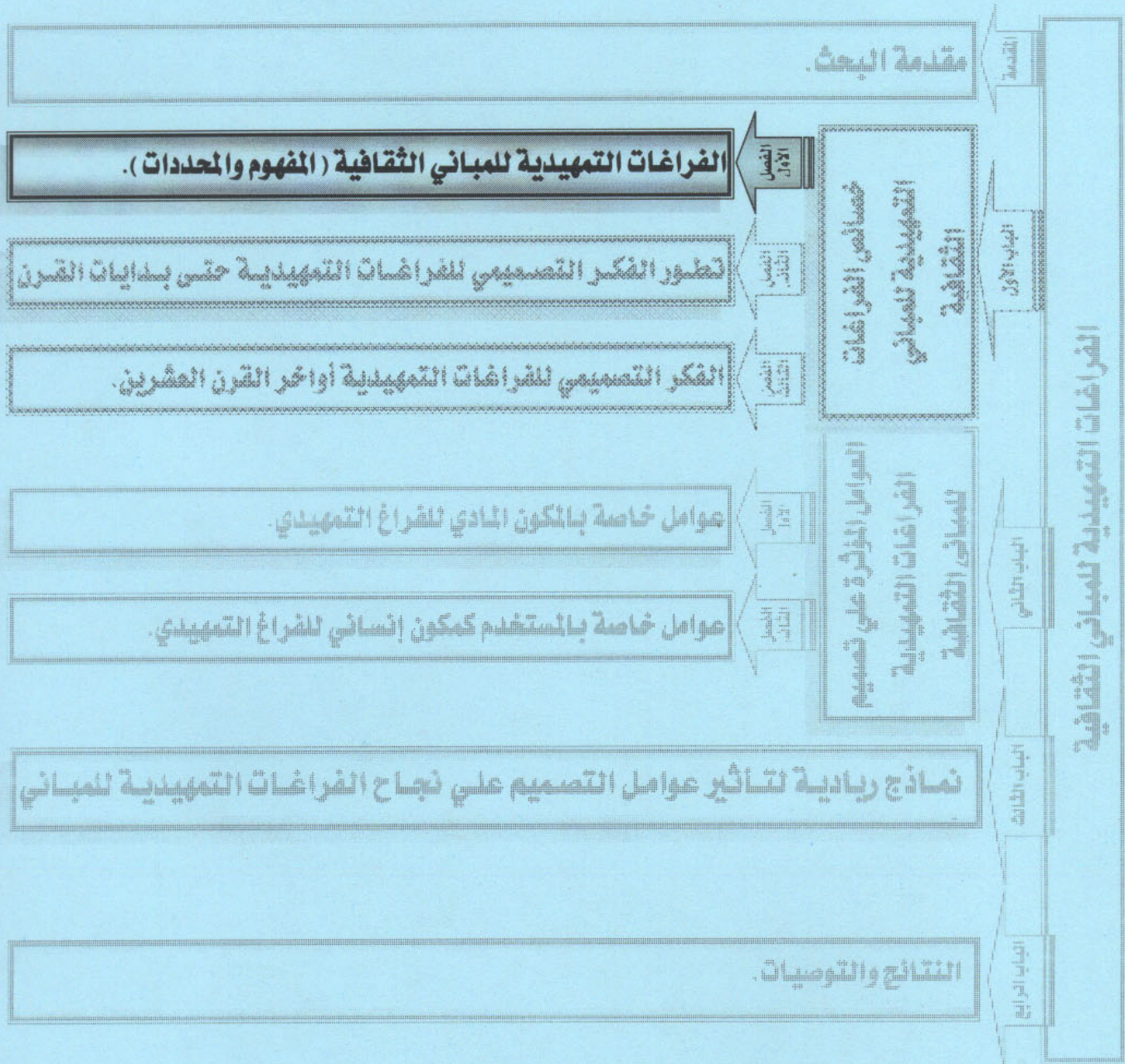

الفصل الأول: خصائص الفراغات التمهيدية للمباني الثقافية

الفراغ العمراني (مفاهيم عامة)

التعريف بالفراغات التمهيدية للمباني الثقافية

١-١-١ - تصنيف الفراغات التمهيدية للمباني الثقافية

١-٢-١ - محددات الفراغات التمهيدية للمباني الثقافية

خلاصة الفصل الأول

() : () :

:()

:

-

-

(Natural Open Spaces)

()

(Urban Spaces)

:

•

:

•

•

.()

" _____ "

1

" _____ () _____ "

2

/ " _____ " :

3

:

4

Dee, Catherine, "**Form and Fabric in Landscape Architecture, A visual Introduction**", spon Press, London, 2001.
Lang, Jon, "**Urban design: The American Experience**", Van Nostrand Reinhold, New York, 1994.
Lynch, K. "**The image of the city**", Cambridge MIT Press, USA, (1963).
Norman, K. Booth, "**Basic Elements of Landscape Architectural Design**", Waveland Press, Reissue edition, 1989.
Spreiregen, Paul, "**Urban Design: The Architecture of Town and Cities**", McGraw-Hill Co., New York, 1965.

)

:

(

•

○

○

○

:

:

•

:

•

•

(

)

:

□

□

□

□

□

:

•

:

•

:(

)

•

() : () :

: •



:

(-)

: •



:

		:
		:
		:

()

):

():

		:
		:
)	:

(-)

: *

- -

○

○

○

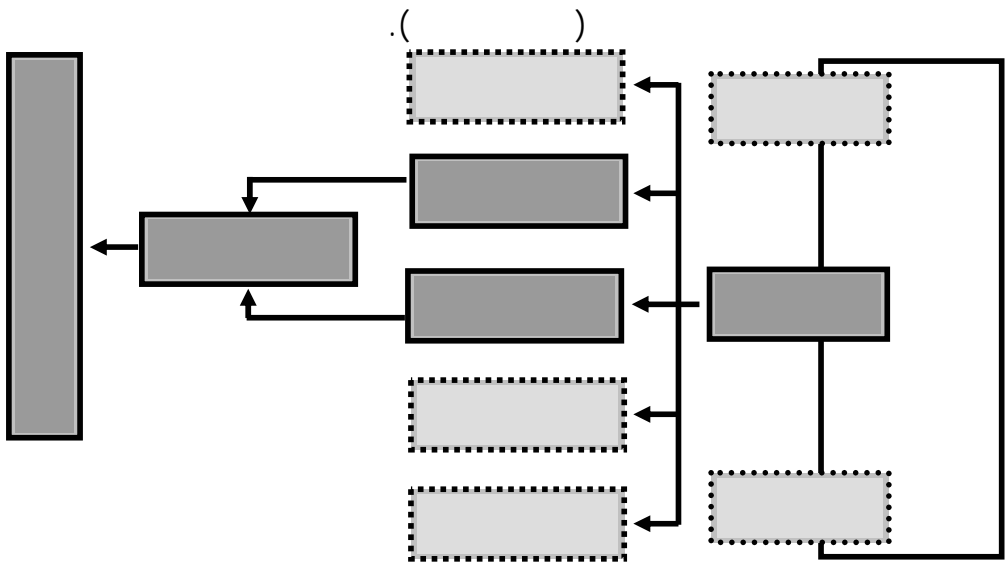

)

*

.(

:(Approach Spiral) (-) (

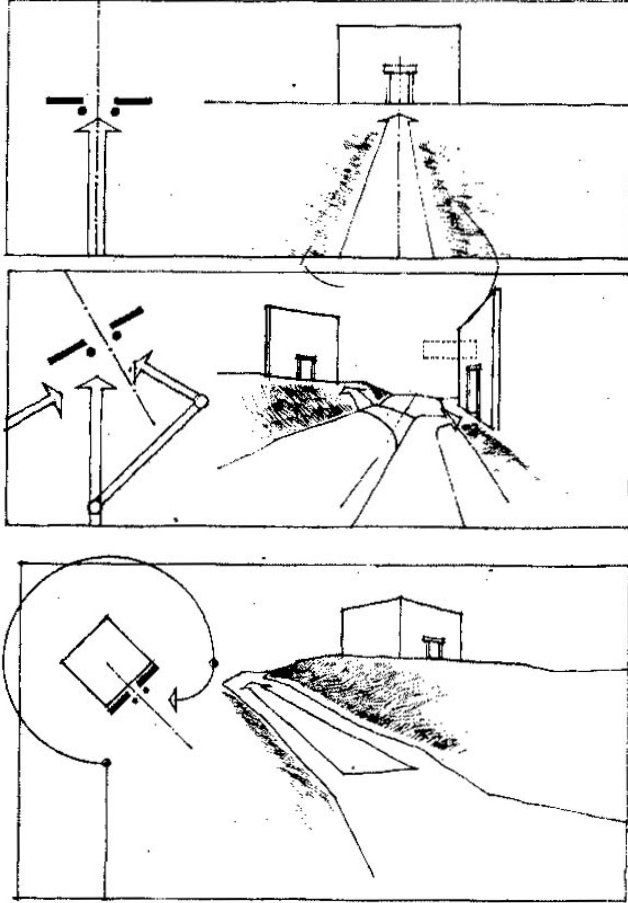

.Architecture- Form- Space & Order,p249.:

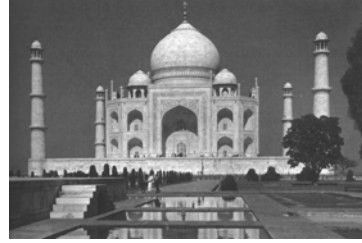

()

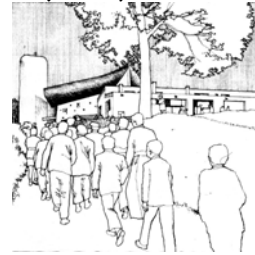

()

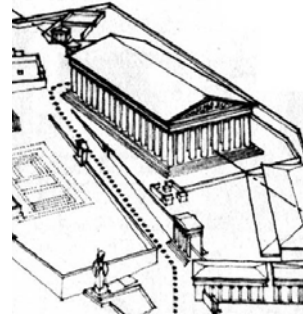

()

(-)

:

:

:

(

•

•

•

(

•

•

•
:
(
•
•
:
(
•
•
(
(
(
(

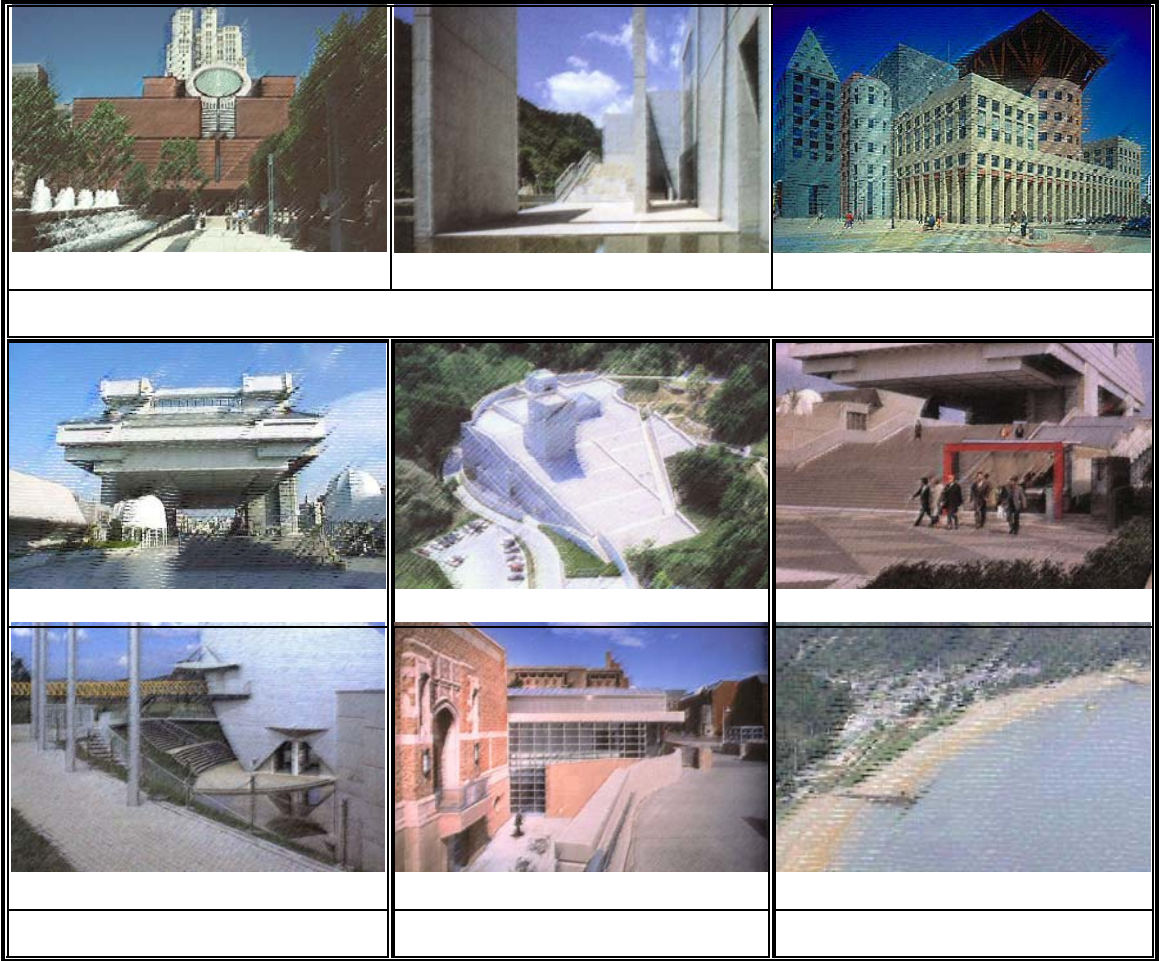

: _____
: - - - -

:
:(Key - Hole) (

- -
:(Picture Frame) (

:(Dead - Stop) (

:(invitation) (

:(Deflection) (

:(Wings) (

:(Y-Trap) (

:(Folding Screen) (

:(Narrows) (

:(Fluctuation) (

:(Closure) (

:(Anticipation) (

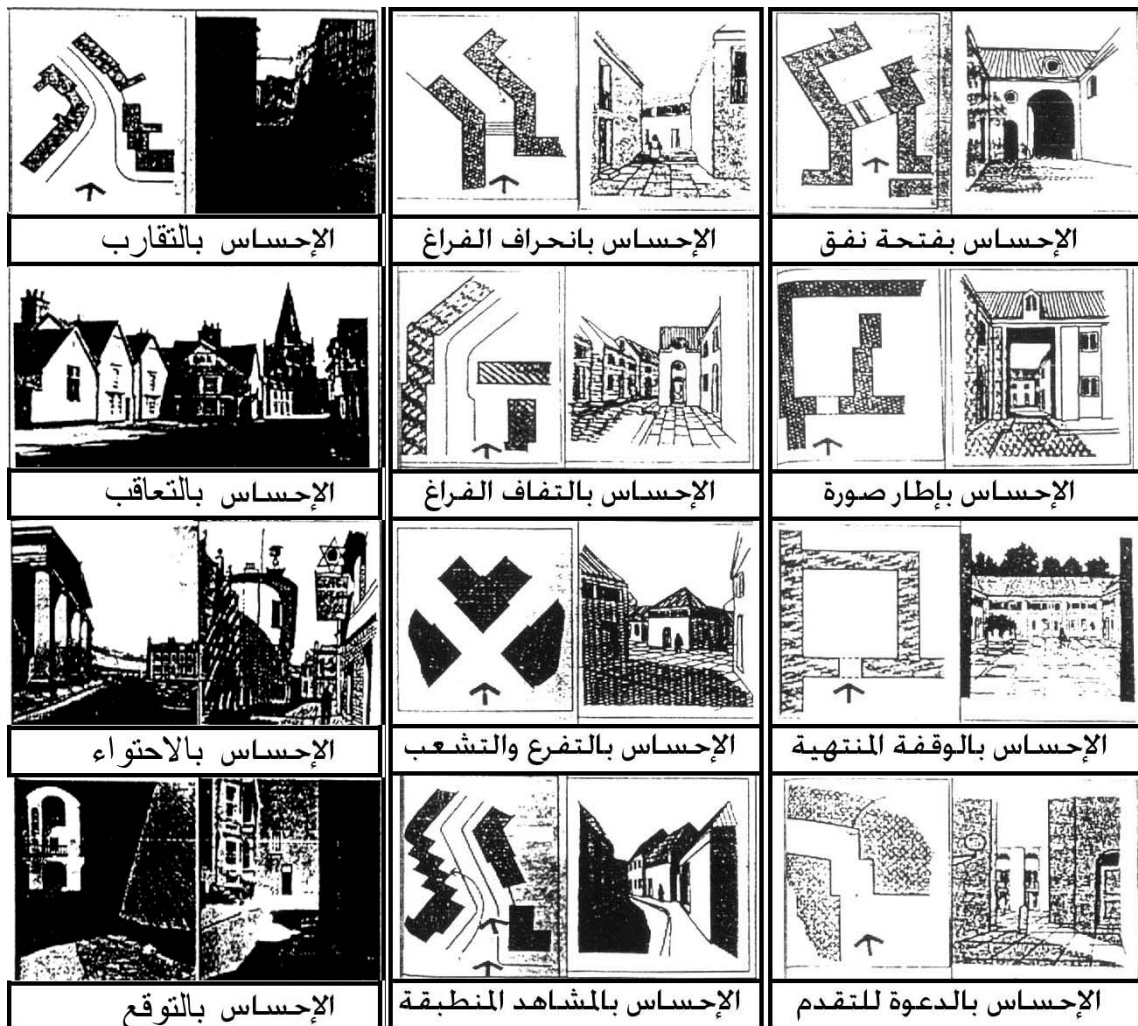

(-)

() : () :

: - - - -

- - - - -

.

:

• •
• •

:

- - - - -

-)

(..

)

(

: (

: •



(-)
المصدر: "Urbanism ,p66."



(-)
المصدر: " Urbanismo Squares,p21."

: •

: •

: •

: •

:

- - - -

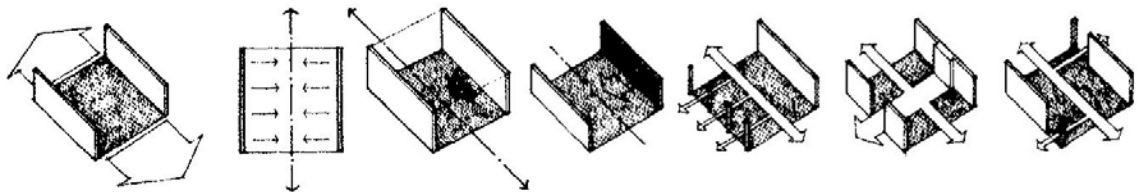

(-)

.Architecture- Form- Space &Order.:

(U)

.(Extroverted)

: -



"Urbanism ,p59.:"



(-)

: -

: -

: -

: - - - -

() : () :

: (

: (

: - - - -

: •

: •

() - " : (

"

: •



(-)
"Urbanismo Squares,p15.":

(-)
"Urbanismo Squares,p80.":

()

):

():



"Urbanismo Squares,p100,120.":

(-)

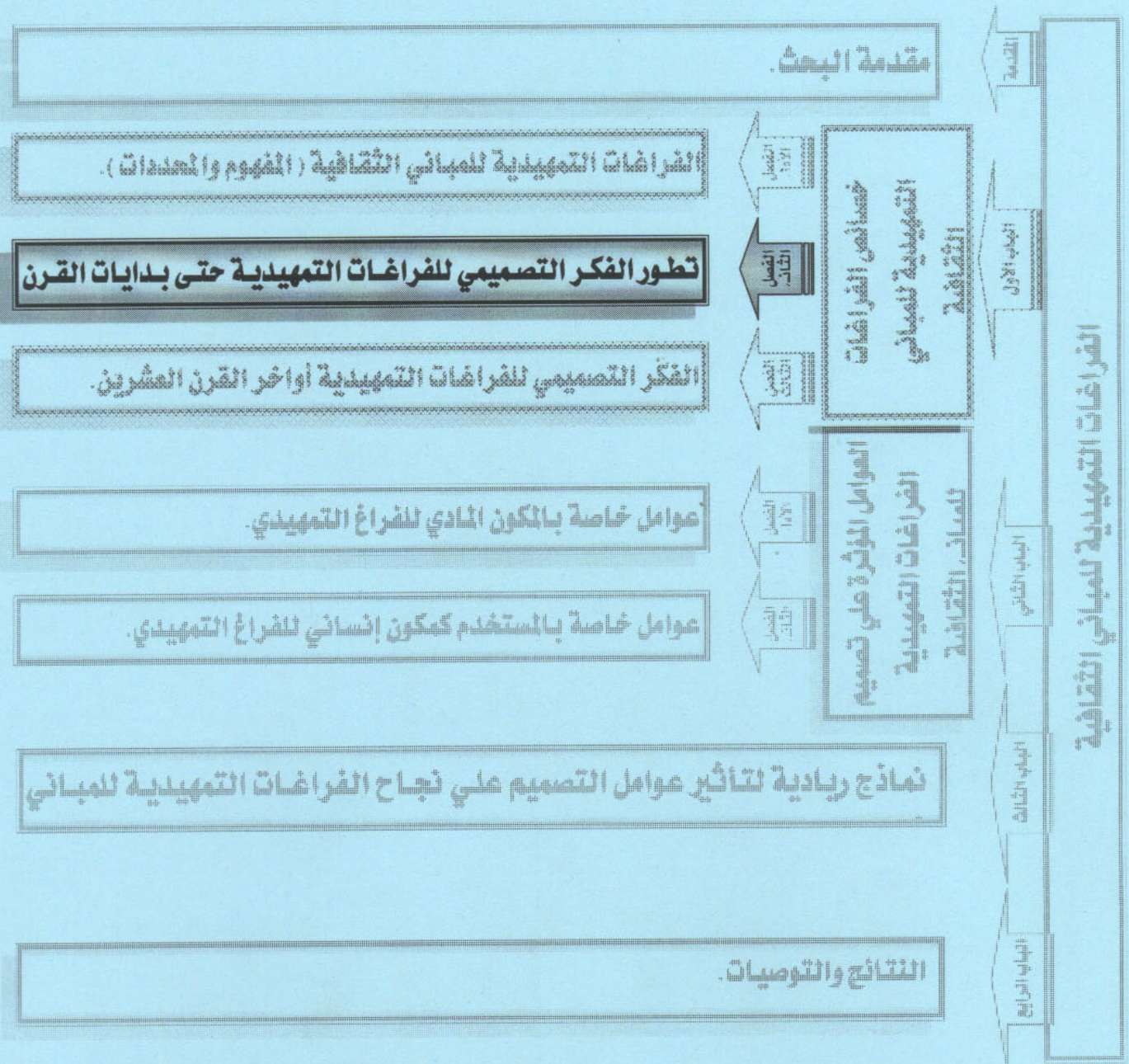

الفصل الثاني: تطور الفكر التصميمي للفراغات التمهيدية حتى بدايات القرن العشرين.

- ١-٢-١ - العصور القديمة.
- ٢-٢-١ - العصور الوسطي.
- ٣-٢-١ - عصر النهضة.
- ٤-٢-١ - القرن الثامن عشر والتاسع عشر.
- ٥-٢-١ - بدايات القرن العشرين.
- خلاصة الفصل الثاني.

(_____): (_____);

: - -

: _____

) (_____)

(

-)

.. (-)

(

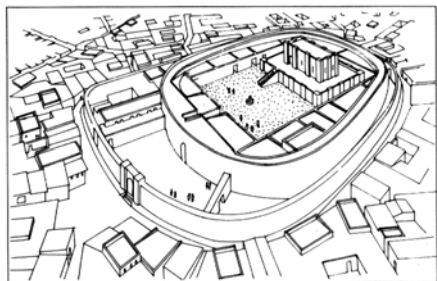

(-)

"Ancient Architecture,p16.":



(-)

: - - -

)

.(

:(_____)

- - - -

)

(

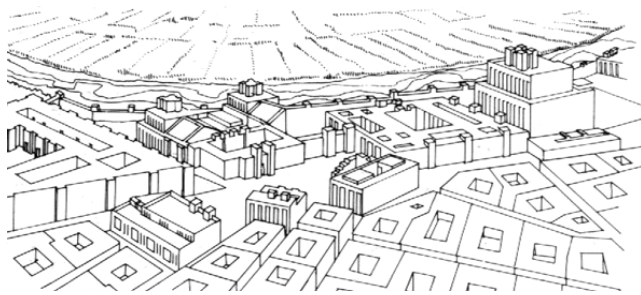

(-)



(-)

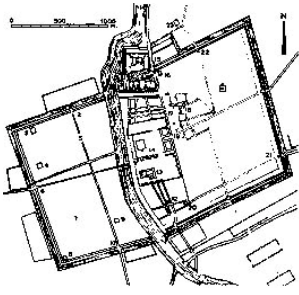

(-)

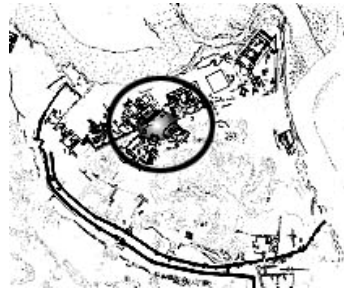

(-)

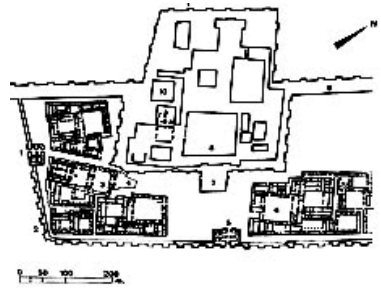

(-)



(-)



(-)



(-)

" Ancient Architecture,Pp.24,29,39,40,62.":

(_____): (_____);

:

..

-)

(-)

(-) (

()

:

•
(
(
(
(
(
(

:

- - - - -

..

-

: (. . -) :

: (. . -) :

" _____ " 4
" _____ " 5
" _____ " 6

:

:

•

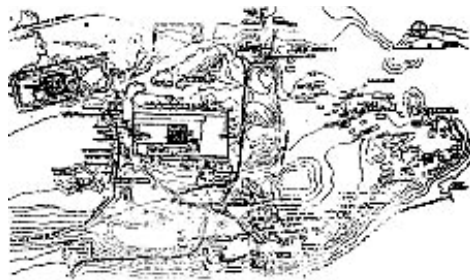

() (-)

"A History of Architecture".:



(-)

":

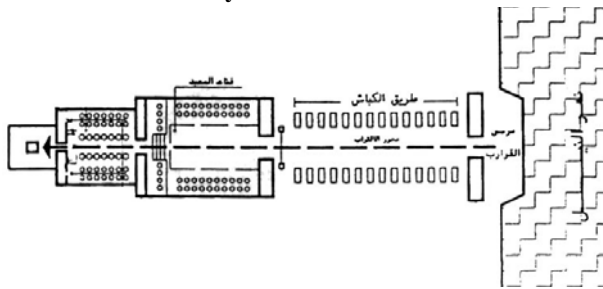

(-)

":

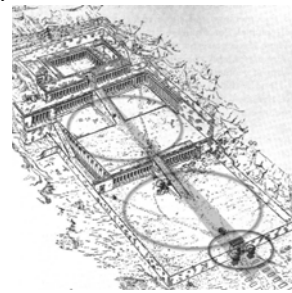

() (-)

"Ancient Architecture,p105".:

()

7

8

9

¹⁰ Newton, T. Norman, "Design on the land", Harvard university press, U.S.A.,1971,P.2.

(-)

:

•

.(-)

(

(

(

(

(

()

(

(

)

(

:

- - - -

)

-

(

:

(Acropolis)

:

:

:

•

¹² Seton, Lloyd, et. al, "Ancient Architecture", Harry N. Abrams, New York, U.S.A., 1974.

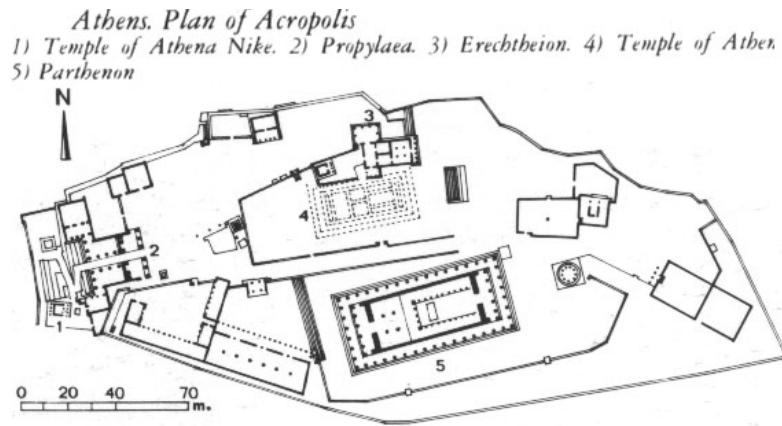

(-)
" "A History of Architecture,p121." ":

(-)
(porticoes)

:

()

	14
" "	15
" "	16
" "	17

: ()

(pire)

: ()

: ()

.(phodes) (Thasos)

%

Assos. Reconstruction and plan of stoa
1) West gate. 2) Temple. 3) Upper floor or baths. 4) Agora. 5) East gate.
6) Bouleuterion. 7) Stoa

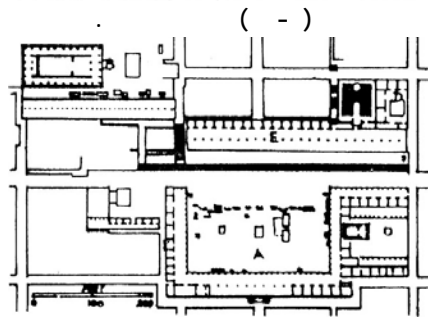
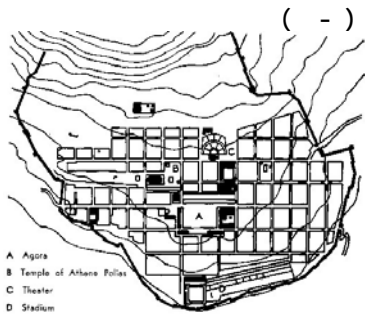
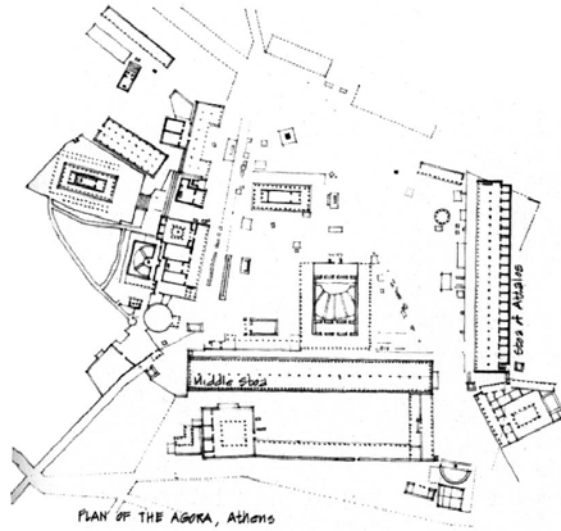
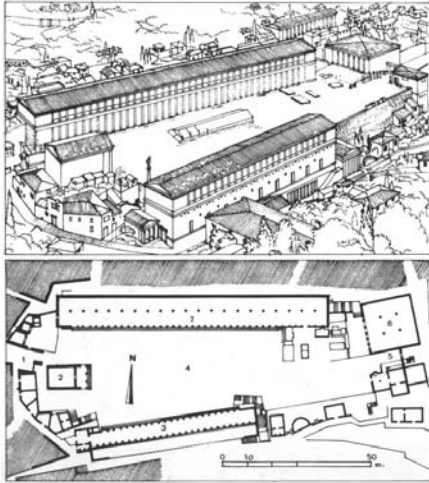

"A History of Architecture, 147.":

:(Parthenon)

(Athens)

(Parthenon)

"Athens"

(-)

()

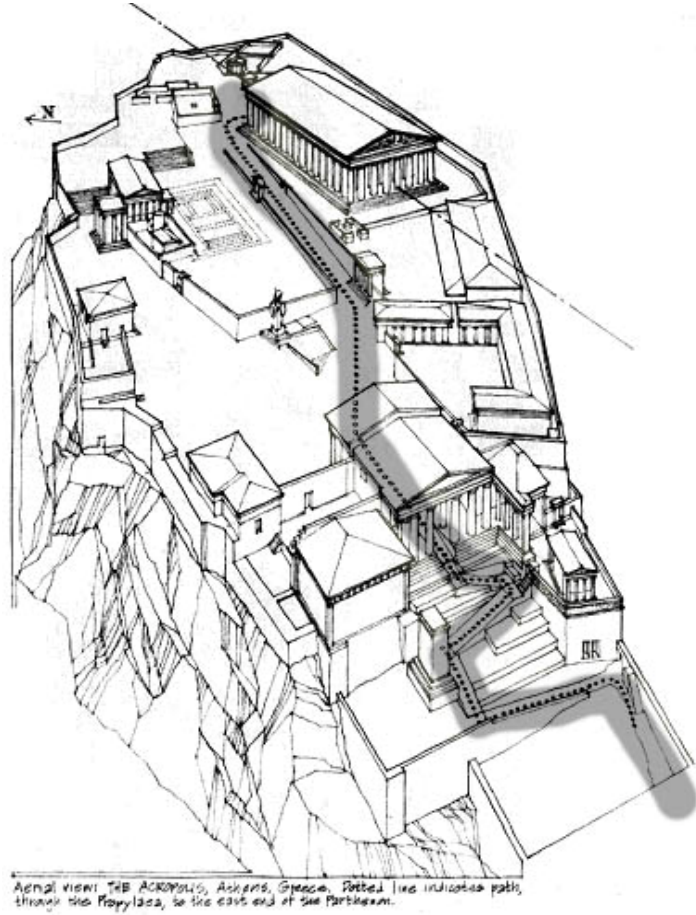

(-)

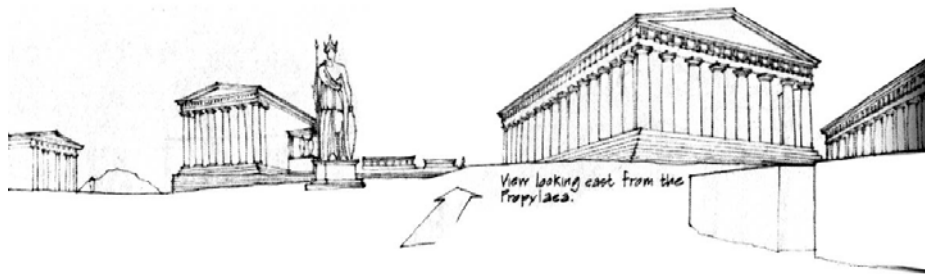

(-)

"A History of Architecture,p132.":

¹⁸ Ching, Francis D.K, "Architecture Form, Space and Order", Van nostrand Reinhold, New York,1979, P254.

(Prppylon)

(

(

(

(

(

(

(

(

:

- - - - -

(. - . . .)

)

(())

:

(

:

:

(forum)

:(-)

.Augustus
.Vispasianni

.Caesaris
.Nerva
.Trajan

:

: •

.()

.(Thermae) () :

•
•
•
•

" " 21

" " 22

" " 23

()

24

)

.(:)

" :

"

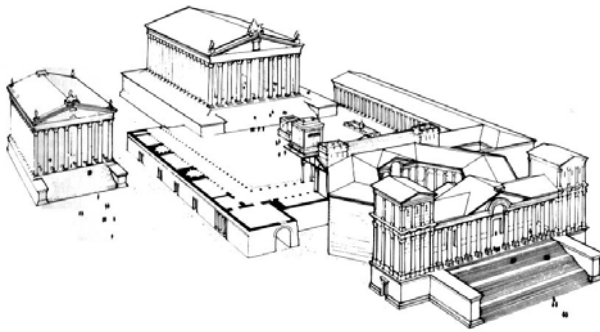

(-)



(-)

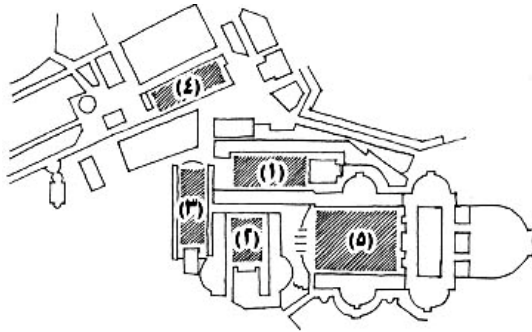

(-)



(-)

"A History of Architecture,p253.":

(Trajan)

(. -)

(_____): (_____);

- : •
(:)

(..)

29

* : •
: •
:

: ○
(
(
(
(
(
(
(
(

²⁸ Cruickshank, Dan, "**A History of Architecture**", Architecture Press, 20th edition, P.238. 27
() _____ 29

(): ();

: - - -

: - - - -

(-)

(Early Christian, Romanesque and Gothic Styles)

: _____

: _____

: _____



(-)



(-)

"A History of Architecture,p481.":



(-)



(Trier, Hauptmarkt)

(-)

"www.carfree.com".:

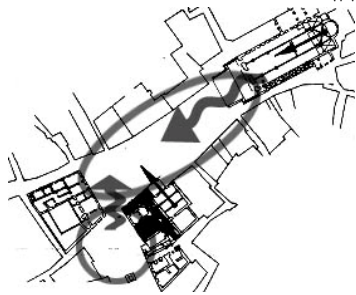

(-)

"A History of Architecture.".



(-)

"www.carfree.com".:

:

•

• • • • •

:(**Todi**) (Duomo)
(Pizza Del Popolo) () –

– (Pallazzo Del Priori)

(Pallazzo Del Popolo) (Todi)

(The Mayor's Palace) (Plazzo Del Capitano)
Pizza Del) () (Garibaldi)

:(**Pizza Del Gribaldi**) ()

:(**Pizza Del Popole**)

³² Cruickshank, Dan, "A History of Architecture", Architecture Press, 20th edition, P.894.



(-)



(-)



(-)



(-)



(-)



(-)

:

:

•

:

:

(_____): (_____);

:

:

:

(_____) (_____)

(_____)

_____ " _____ " 35

_____ " _____ " 36

_____ " _____ " 37

(): _____

(): _____



(-)

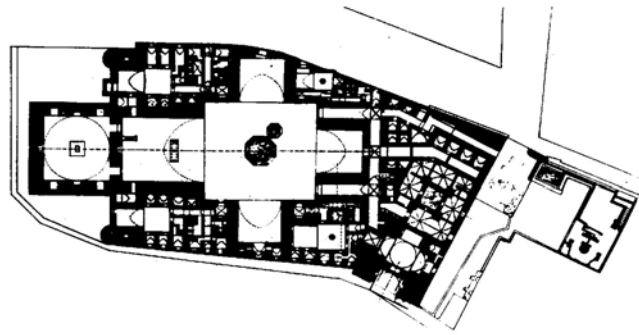

(-)



(-)

:

(
(

(_____): (_____):

(

(

(

(

(

: - - -

()

:

-
-

(Scamuzzi)

(Geometry)

(order)

(Reason)

(Versailles)

: - - - -

(FORMAL SQUARE)

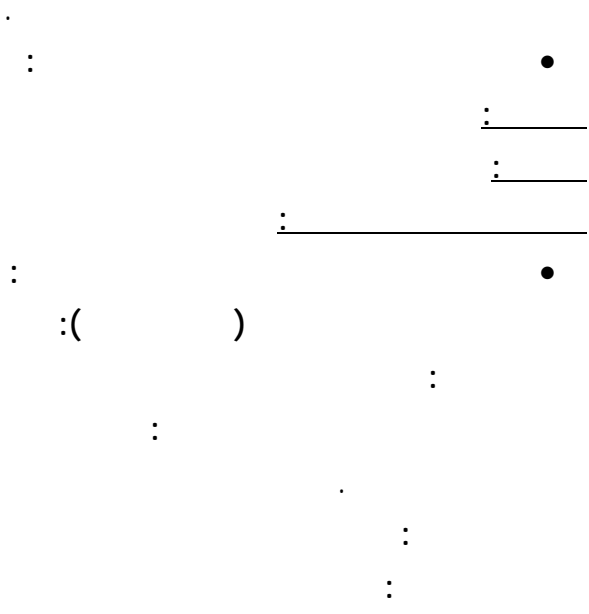

:()

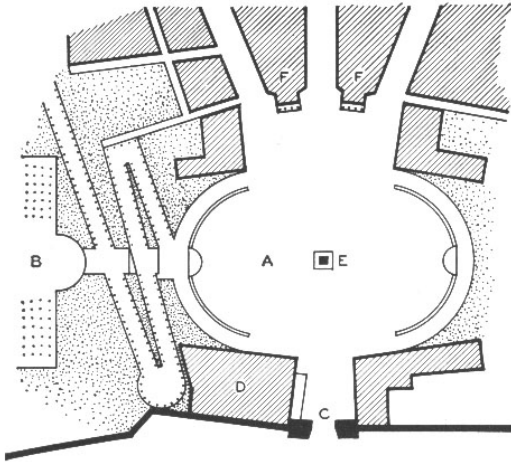

PIAZZA DEL POPOLO, Rome

- A Piazza
- B Pincio Hill and Gardens
- C Porto del Popolo
- D Church of Santa Maria del Popolo
- E Obelisk
- F Twin Churches by Rainaldi

.(Piazza Del Popolo) (-)

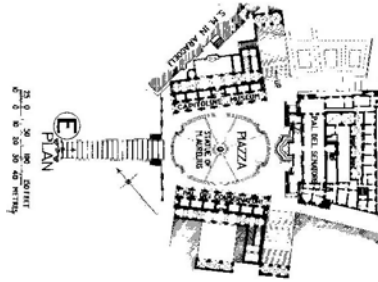

(-)

"A History of Architecture.":



.(Milan, Piazza Duomo) (-)



.(Brugge, Grote Markt) (-)



Clermont) (-)

.(Ferrand, Place de Jaude

"www.carfree.com"::

:

•

()

(
(
(
(
(

: - - - -

()

:

•

()
(TUILLERIES)

(CHAMES ELYSEES)

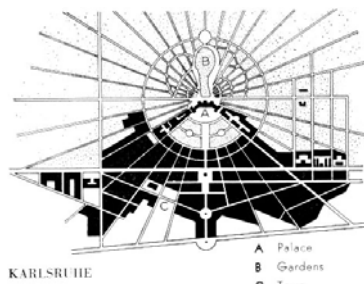

(Karlsruhe) (-)

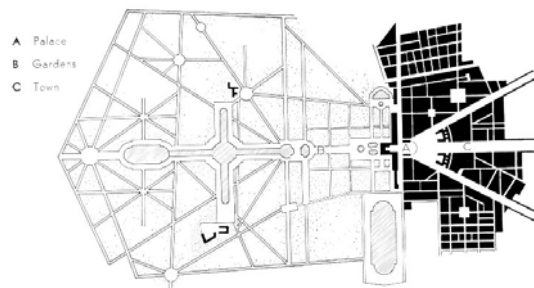

(-)

"A History of Architecture.":

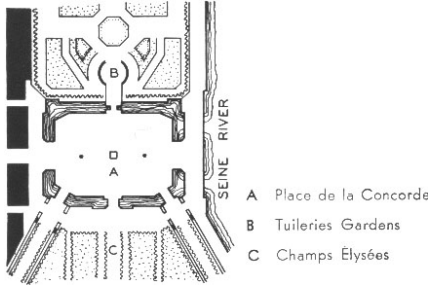

(-)



(Zürich, Bahnhofplatz)

(-)



(-)

"www.carfree.com":

(Etolle)

-) (St. Peter)

: ((St.Peter)

(Pope Julius)

(Donato Bramonto)

(Michel Angelo)

(Bernini)

(Carlo Maderna)

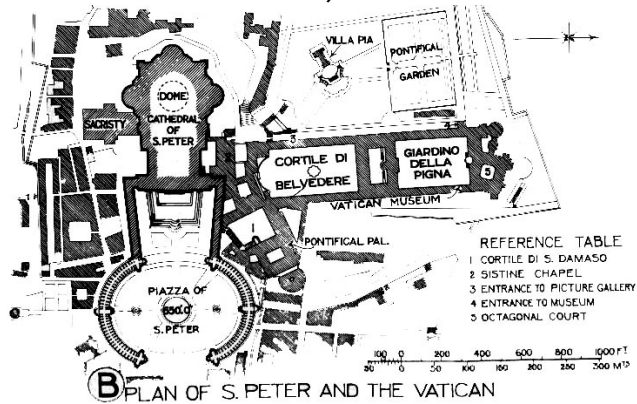

(-)

(-)

"www.carfree.com"::

"A History of Architecture."::

(SIXTEY)

(Borgo)

(

):

(

):



(-)

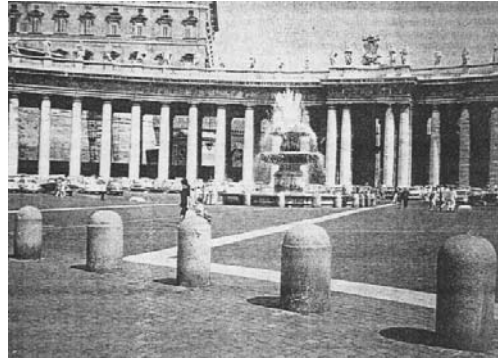

(-)

"www.carfree.com"::

:(Borgo)

: •
(
(
(
(
: - - -

(Western Classicism) :
(English school) (Chinese school)

(Chales Bridgeman) (Wiliam Kent) ()
(Mumphrey Repton)

.()

()

()

()

()

(Dowings)

(Olmsted)



(Place Des Terraux) (-)

(www.carfree.com) :

By: J.Gastineau (Archives Municipales de Lyon) :

:

(

(

(

(

(

:

- - -

()

(_____): (_____);

(_____)

(_____) . (boulevard)

· : ·

· : · ●
(
(
(

(_____): (_____);

: _____

(...)

:

.

•

•

•

•

•

•

•

(

•

•

•

•

•

•

•

•

•

)

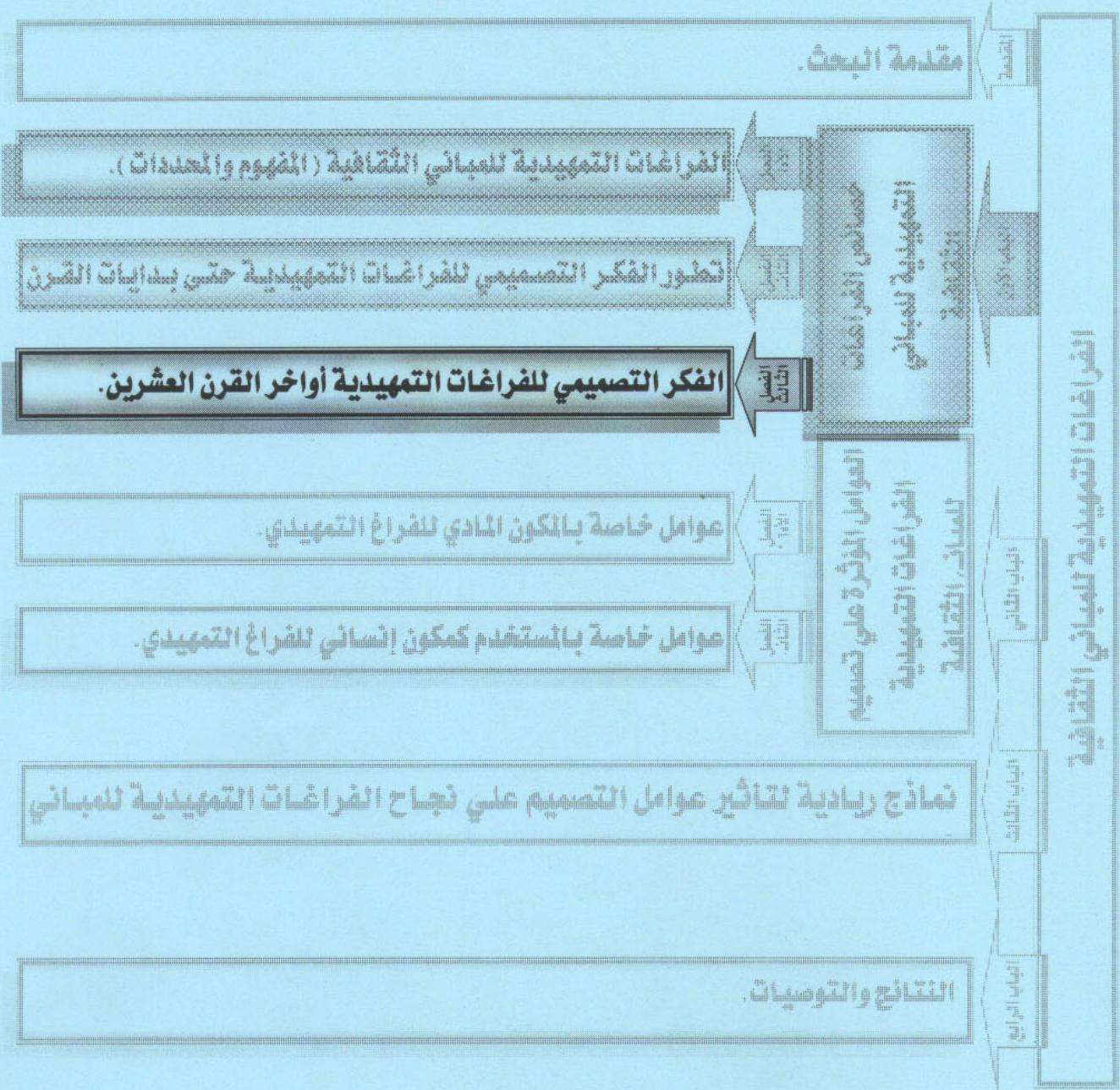

الفصل الثالث: الفكر التصميمي للفراغات التمهيدية أواخر القرن العشرين.

أسس اختيار عينة الدراسة

- ١-٣-١ - تصنيف الفراغات التمهيدية وفقا لعلاقة الفراغ بمدخل المبنى
- ٢-٣-١ - تصنيف الفراغات التمهيدية وفقا لطريقة الدخول للمبنى
- ٣-٣-١ - تصنيف الفراغات التمهيدية وفقا للمعاني الإيجابية التي تنقلها للمستخدم

خلاصة الفصل الثالث

(): ():

:

- -

: _____

(-)

(-)



(-)

(-)

*

: _____

:

()

•

•

()

•

•

(_____)

_____ " " 1

*

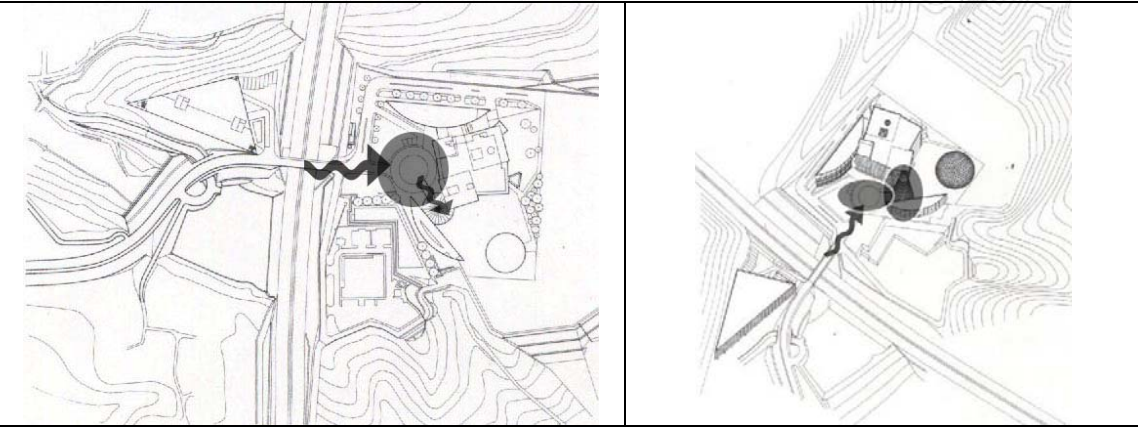
. (Ehime Prefectural museum of science) (-) (-)		
:	.(Kisho Kurokawa)	
(- -) (Metabolism) ()		
		
		
<p>•</p> <p>•</p>		

³ Henderson, J., "**Museum Architecture**", Rockport publishers, USA,(1998), P.126.
⁴ Jeremy, M., "**New Public Architecture**", Calmann &King Ltd, London,(1996) , P.130.

(- (Raleigh)) (-)
(North Carolina Museum of Art)

: (Barbara Kruger)

(- -)

.







.

•
•
•
•

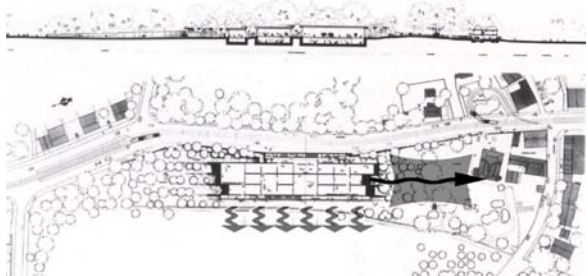

⁵ <http://www.ncartmuseum.org/museumpark/events.shtml>

⁶ Henderson, J., "Museum Architecture", Rockport publishers, USA,(1998), P.60.



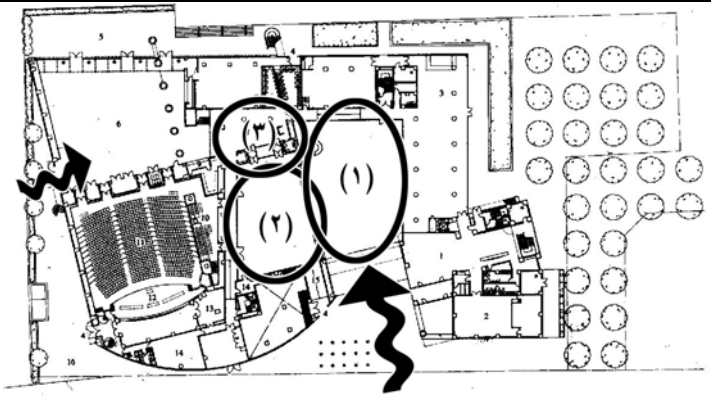
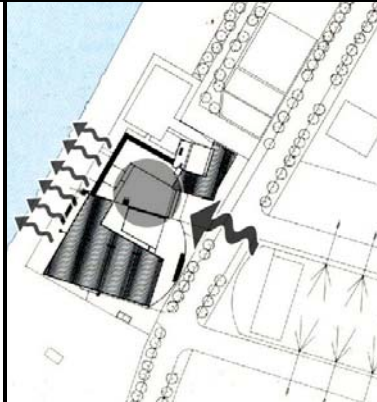

(Beyeler Foundation Museum) () (-)		
:	.(Renzo Piano)	
		
		
		

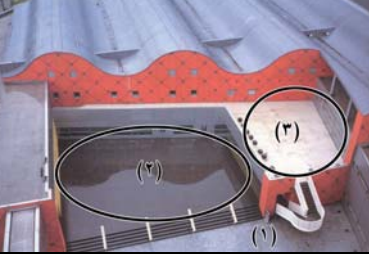
⁹ http://www.beyeler.com/fondation/e/html_01start/01_sta_main.php

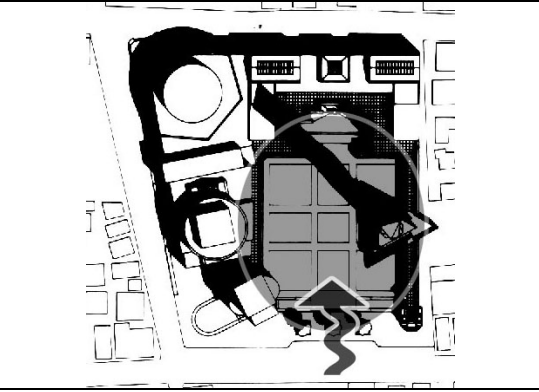

¹⁰ Henderson, J., "Museum Architecture", Rockport publishers, USA,(1998), P.72.

(-) (-) (Kitakushu Conference Center)		
	.(Arata Isozaki)	
() () (U)		
		
		



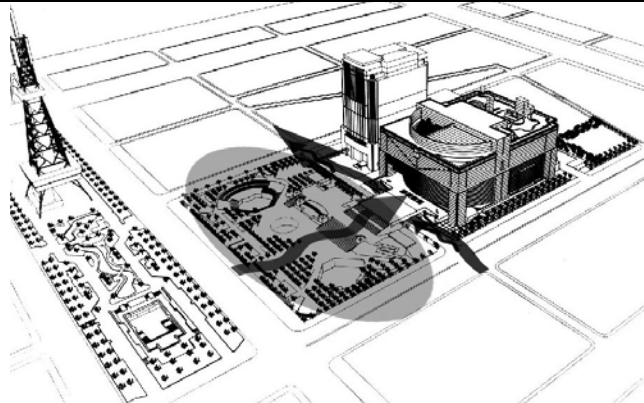

¹⁸"Theatre & Halls", Meisei Publications, Japan,(1995), P.200.

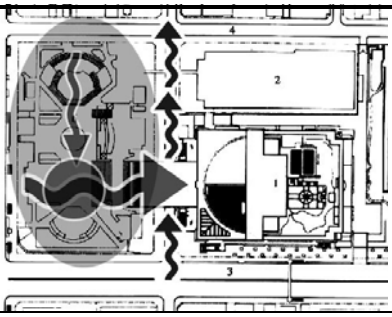
. (Art Tower Mito) (-) (-)		
:	.(Arata Isozaki)	
()	()	
		
		
		• • •

²⁰ "Theatre & Halls", Meisei Publications, Japan, (1995), P.104.

. (Aichi Arts center) (-) (-)		
:	A& T Associates.	
()	()	()
)		
		
		
<ul style="list-style-type: none"> • • 		

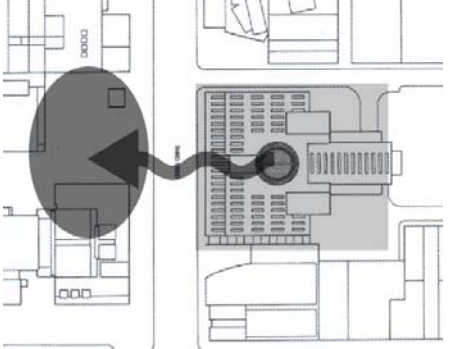



²¹ "Theatre & Halls", Meisei Publications, Japan, (1995), P.144.

<p>(-) (-)</p> <p>.(San Francisco Museum of Modern art) (</p>		
	<p>.(Mario Botta)</p>	
<p>()</p>		
		
		
<ul style="list-style-type: none"> • • 		

²² <http://www.sfmoma.org/>

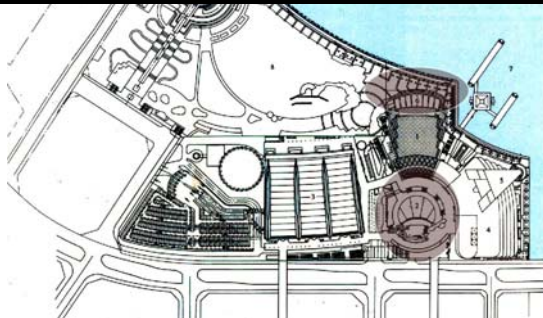

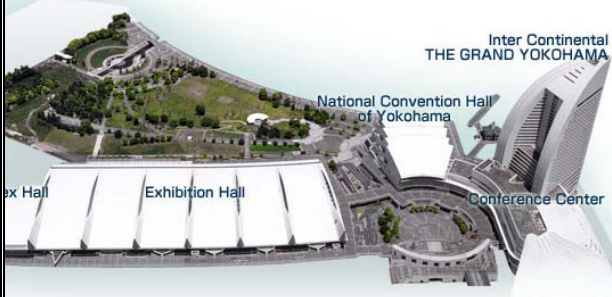
²³ Henderson, J., "**Museum Architecture**", Rockport publishers, USA,(1998), P.46.

²⁴ Hourston, L., "**Museum Builders2**", Wiley-Academy, Britain,(2004), P.109.

() (-) .(National Convention Hall of Yokohama)		
	.(Nikken Sekkei)	
		
		
) .(
	.()	

²⁸ <http://www.pacifico.co.jp/english/>

²⁹ "Theatre & Halls", Meisei Publications, Japan, (1995), P.208.

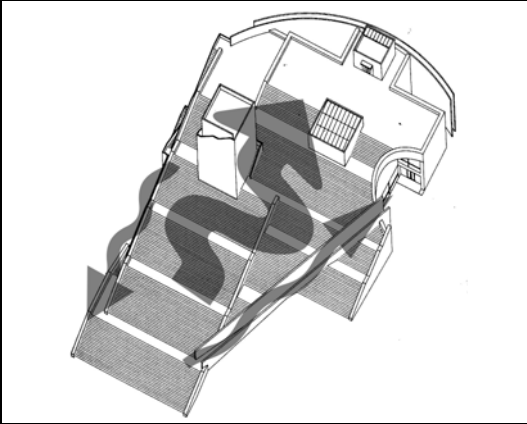
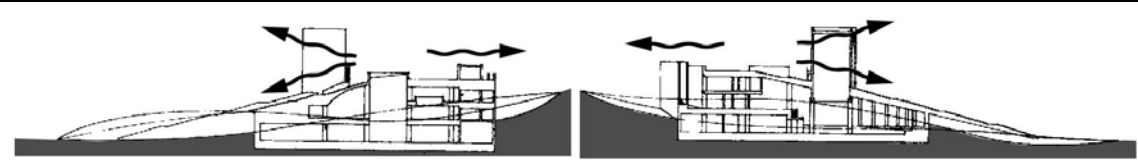
() (-) .(Chikatsu Ausaka Historical Museum)		
	.(Tadao Ando)	
		
		
● ● ●		
	.()	





³⁶ http://www.mediajoy.com/chikatsu/index_e.html

³⁷ Henderson, J., "Museum Architecture", Rockport publishers, USA,(1998), P.158.

³⁸ Hourston, L., "Museum Builders2", Wiley-Academy, Britain,(2004), P.69.

<p>(Katsushika Symphony Hills) (-) (-)</p>	
<p>:</p>	<p>AXS Satow</p>
<p>() ()</p>	
	<p>()</p>
<p>)</p> <ul style="list-style-type: none"> • • <p>.(</p>	
	<p>.()</p>

³⁹ "Theatre & Halls", Meisei Publications, Japan, (1995), P.16.

(Tokyo Edo Museum) (-) (-)		
:	.(Kiyonori Kikutake)	
		
		
<ul style="list-style-type: none"> • • • 		
.() ()		

⁴¹ <http://www.edo-tokyo-museum.or.jp/english/index.html>

⁴² Jeremy, M., "New Public Architecture", Calmann & King Ltd, London,(1996) , P.42.

(): ();

-
-

:

- - -

:

- - - -

:

:

(

(_ _ _)

-
-
-
-

:()

(

()

-
-
-

(_____): (_____);

•

:

(

•

•

•

•

:

:

(

)

(

•

•

:

(

•

-
-
-

: - - - -

: (

-
-
-
-

: (

-
-
-

: - - - -

: (

•
•
:

•
•
•

: - - - -
()

: - - - -
.()
:

(-) - -
:

•
•
•

(_____): (_____):

: _____

() ()

: _____

()

.

.

.

:

(

()

)

()

(

:

.

.

.

.

-
-
-
-
-

()

()

•

•

•

•

:

()

(

:

•

•

•

•

•

•

•

)

(

•

•

•

•

•

•

•

•

()

()



.

:

:

(

•

•

•

•

•

•

•

•

•

•

•

•

•

•

•

•

•

•

•

•

()

()

)

.(

•

•

•

•

•

•

•

)

.(

•

•

•

•

•

•

•

•

•

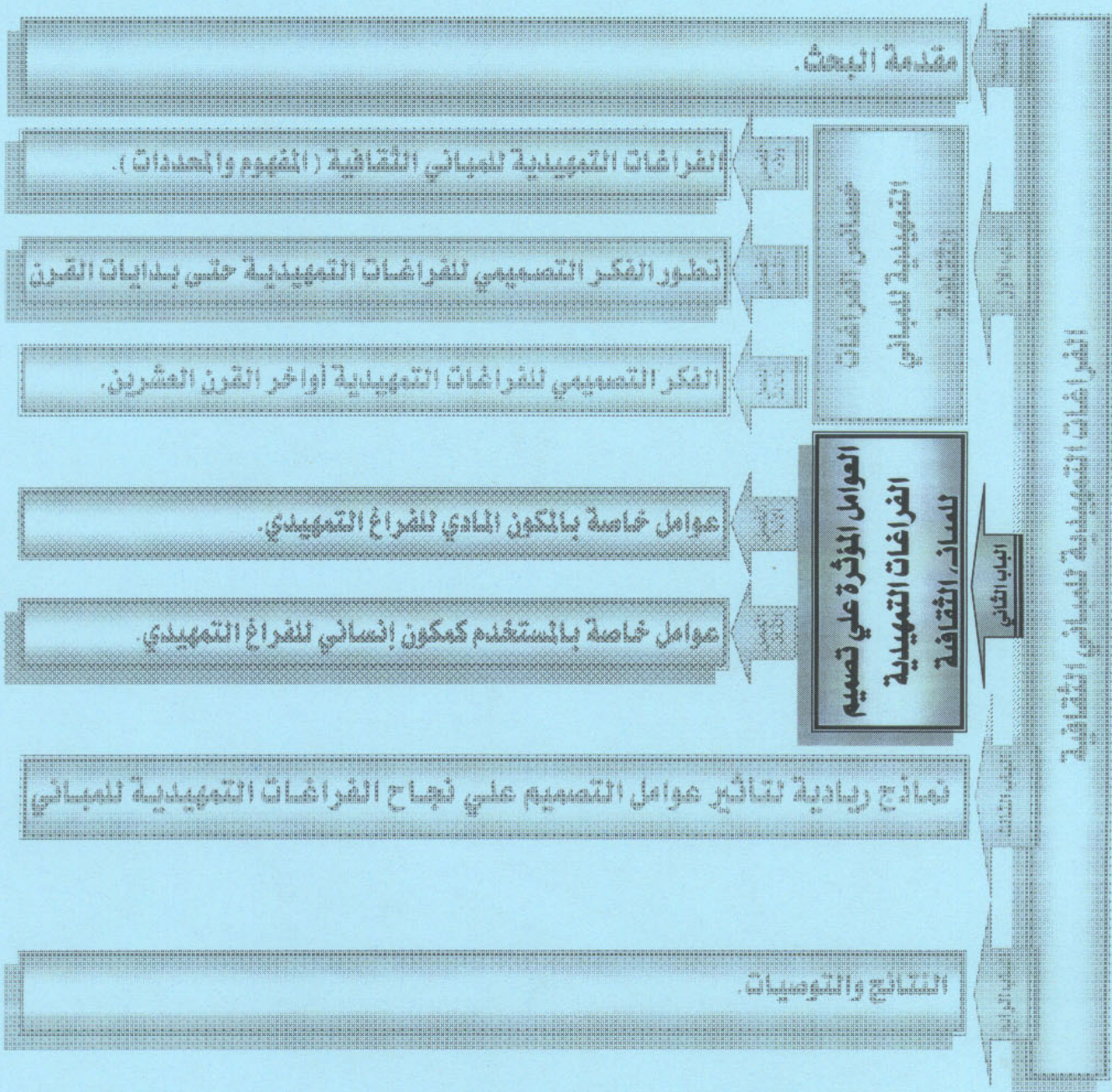

الباب الثاني: ويتناول دراسة العوامل المؤثرة علي تصميم الفراغات التمهيدية للمباني الثقافية، وذلك من خلال فصلين:

الفصل الأول ويتناول **العوامل المؤثرة علي تصميم المكون المادي من المنظومة الثقافية** مع التركيز علي الشق السالب من المكون المادي وهو الفراغ التمهيدي للمبني الثقافي

والفصل الثاني ويتناول **العوامل المتعلقة بالمكون الإنساني للمنظومة الثقافية** وهو مستعمل الفراغ التمهيدي للمبني الثقافي ويخلص الباب إلي مجموعة من العوامل التي يفترض أنها هي التي تؤثر علي نجاح الفراغ التمهيدي للمبني الثقافي.

(_____): (_____)

:

-

-(_____)

-

)

(

)

(

:

○

○

○

○

○

:

○

○

○

○

○

:



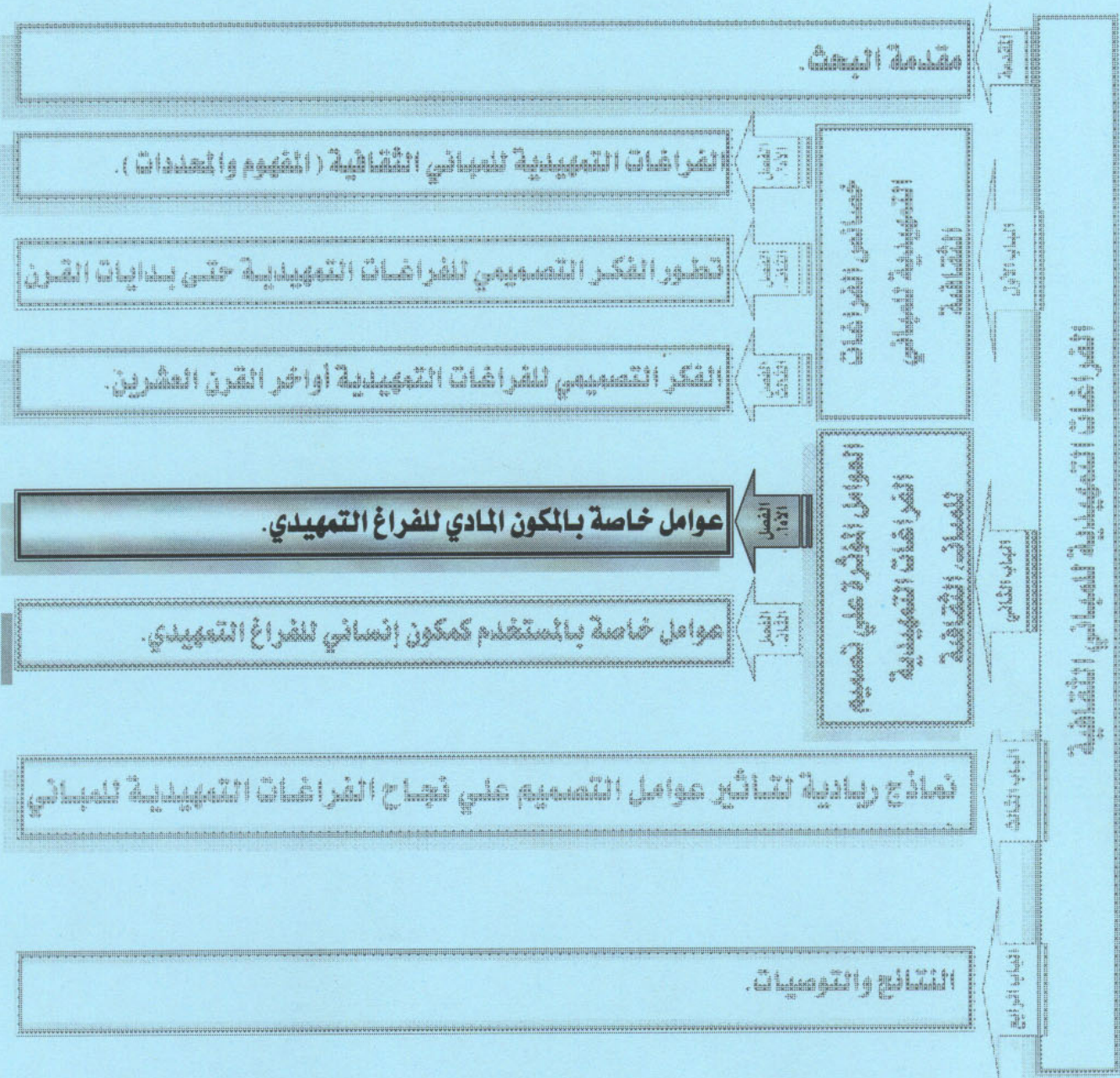

الفصل الأول: عوامل خاصة بالمكون المادي للفراغ التمهيدي

- ١-١-٢ عامل الموقع
- ٢-١-٢ عامل البيئة
- ٣-١-٢ عامل الوظيفة.
- ٤-١-٢ العوامل الجمالية التشكيلية.
- ٥-١-٢ عوامل الحماية والأمن والمراقبة.



¹ Lynch, K., "Site Planning", P.49.
² Carmona, M., "Public Places Urban Spaces", Architecture Press, New York, 2003, P. 610.
³ Lynch, K., "Site Planning", P.58.
⁴ Lynch, K., "Site Planning", P.59.
⁵ Simonde, J. O., "Landscape Architecture", P.P. 113-119.

: ()
•
•
•
•
•
•

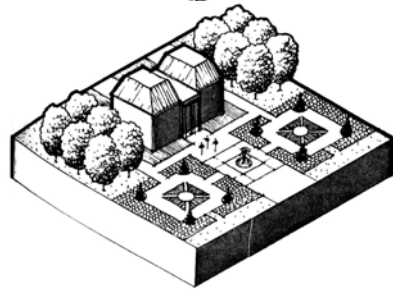
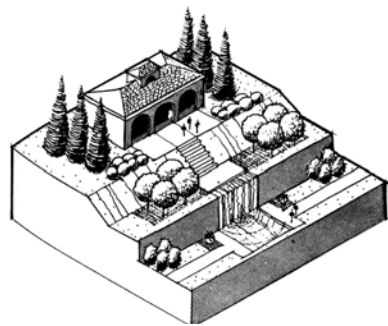

(-)

Basic element of landscape. P.10.:

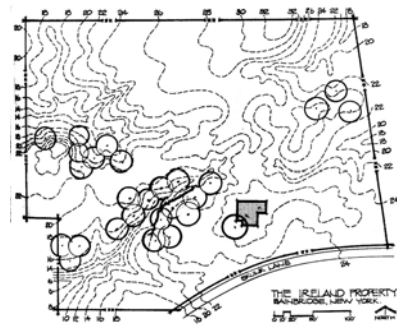

(-)

Basic element of landscape. P.4.:



(-)

Basic element of landscape. P.35.:

: ()

() ()

(Human system)

⁶ Booth, N. K., "Basic Elements of Landscape Architecture", P.P. 34-39.

⁷ Lynch, K., "Site Planning", P.44.

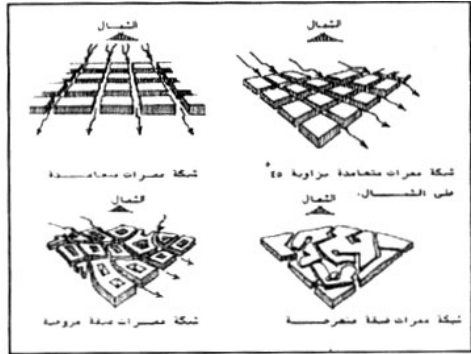
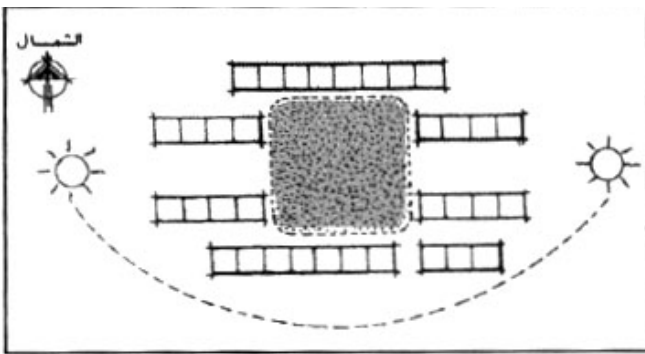
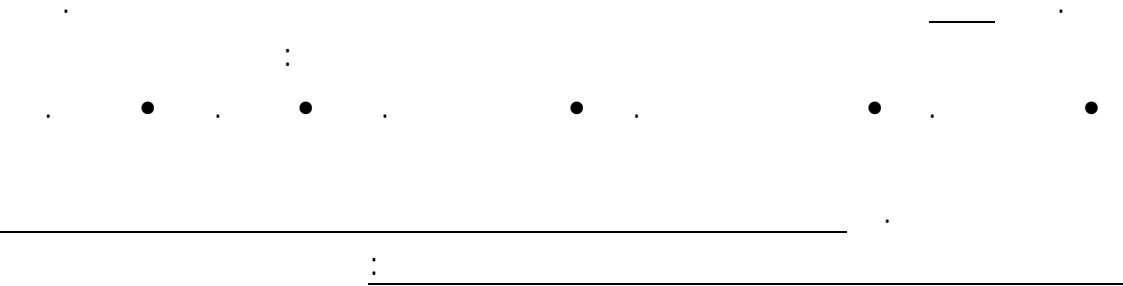

(-)

(-)

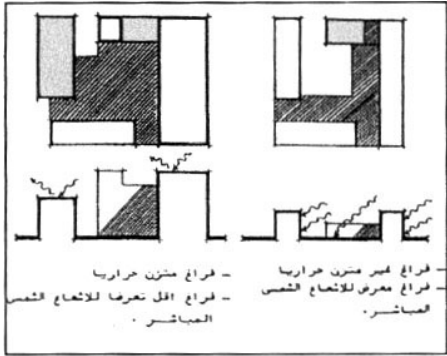

فراغ محير متنون حراريا - فراغ مشنون حراريا
 فراغ معرض للاشعاع الشمس المباشر - فراغ الأقل تعرضاً للاشعاع الشمس المباشر

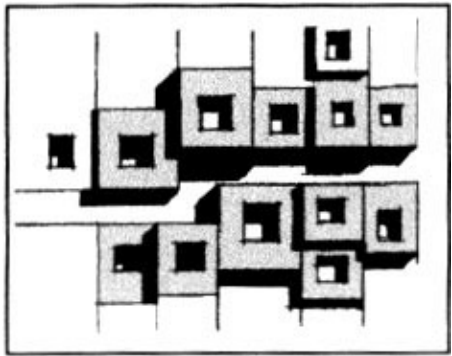

(-)

¹⁰ Lynch, K., "Site Planning", P.74.

:

:

:

12

:

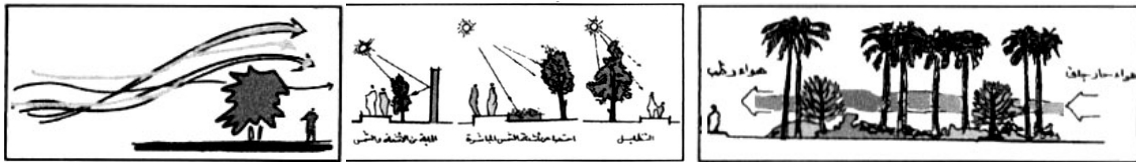

(-)

" " 11

" " 12

14

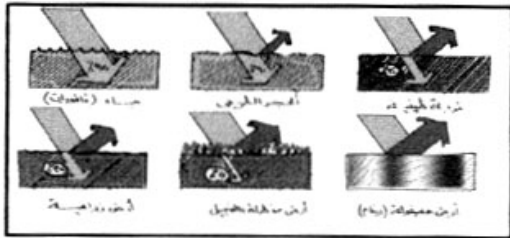

(-)

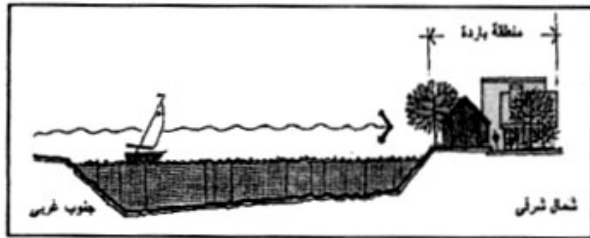

(-)

&

" " " "

13

14

15

() ()

:

:

:

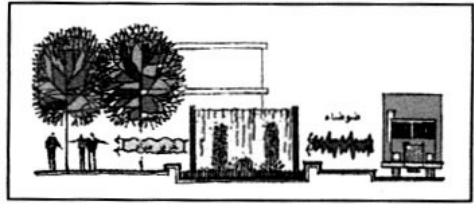
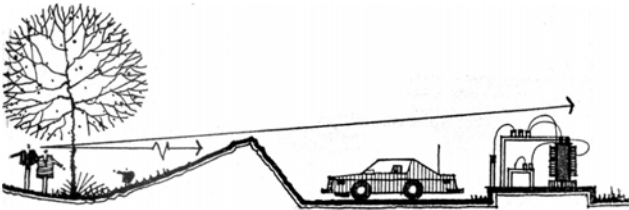

(-)

Basic element of landscape. P.56.:

:

(

" " 16
" " 17

() ()

: - - -

(Kevin Lynch)

(John Habraken)

(ROB Krier)

" "

" "

" "

:

•

•

" "

" " 18

¹⁹ Simonde, J. O., "Landscape Architecture", P.135.

²⁰ Lynch, K., "Site Planning", P.95.

(Land Mark)

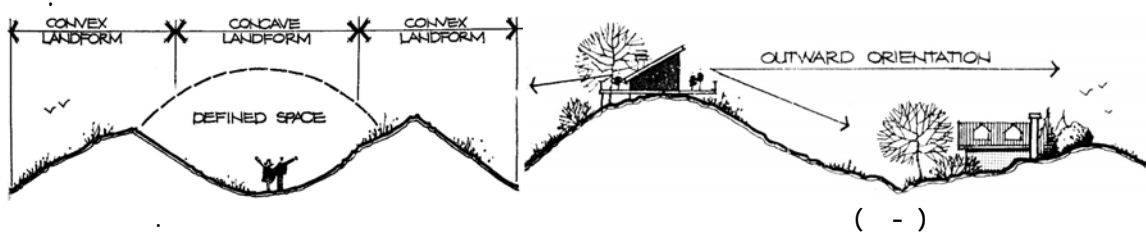

Basic element of landscape. Pp.40,42:

²¹ Simonde, J. O., "Landscape Architecture", P.145.

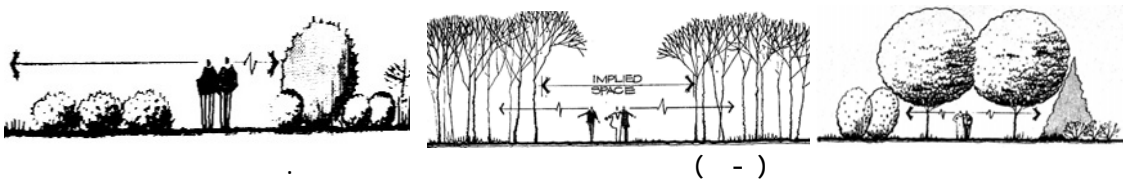

Basic element of landscape. Pp.75,76:

-
-
-
-
-
-
-
-
-
-

: - - - -

- : •
- : •
- : •

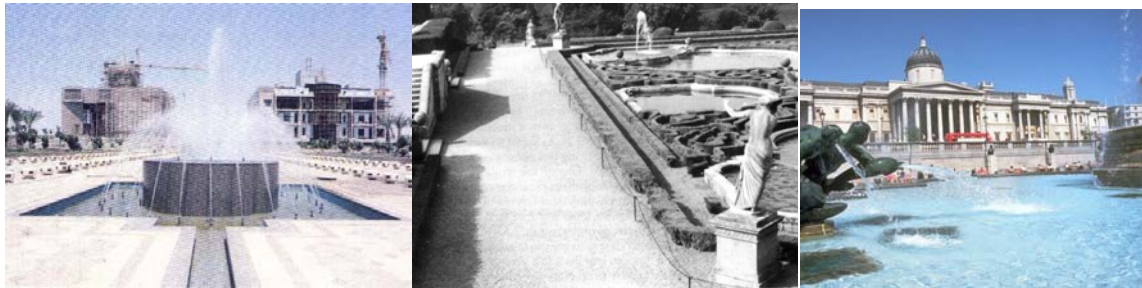

(-)

"Urbanismo Squares." المصدر:

: - - - -

- -) :

(-
: (

:

() ()

:

•

•

:

(

.

:

(

:

(

:

(

:

(

— —

.

" "

() ()

: - - -

(Enclosure)

"the concise townscape" " "

• •

" "

() ()



(-) ()

() () () ()

() () () ()

() () () ()

- (:) (:)
- (Dynamic) - (Static) () - •
- (Directional) - (Stable) () - •
- (Monumental) -(Intimate) - •

²⁶ M. Francis, "**Public Space**", Cambridge University press, 2nd edition, New York, 1995, P187.
²⁷ C. C. Marcus, C. Francis, "**People Places**", John Wiley & Sons, 2nd edition, New York, 1998, P25.
²⁸ J. Mccluskey, "**Road form & Townscape**", Butterworth Architecture, 2nd edition, London, 1992, P92.

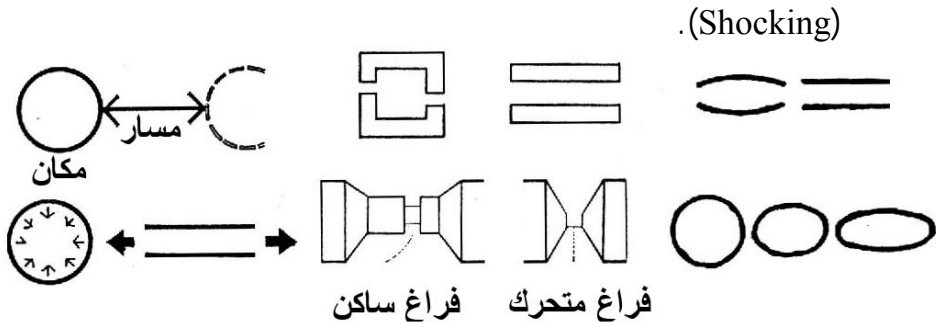

"Road Form,p92.": (-)

(hard Enclosure)

(Soft Enclosure)

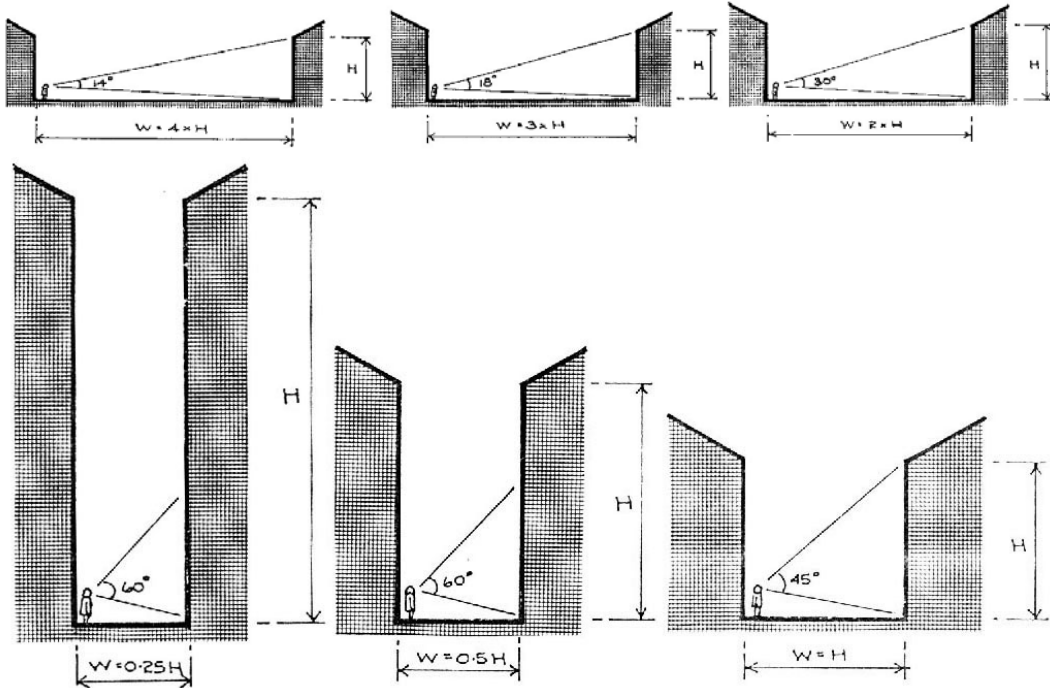

"Road Form,p108-109.": (-)

() ()

:

(:)

:

:

:

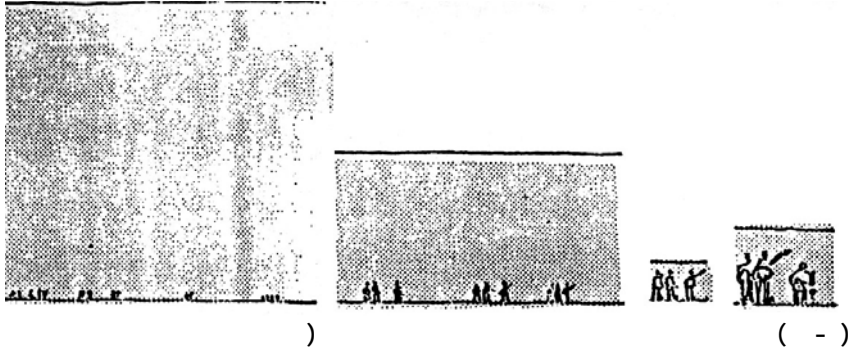
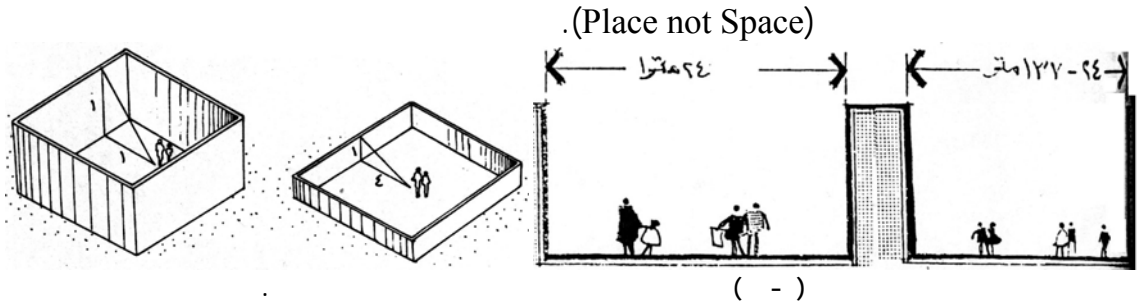

:

٢٩

()

:(Intimate Scale)

(place)

•

29 The Greater London Council Study: "Introduction to Housing Layout", Architecture Press, London, 1980, P.70-71.

) : (Human scale) • (

) : (Monumental Scale) • (

: :

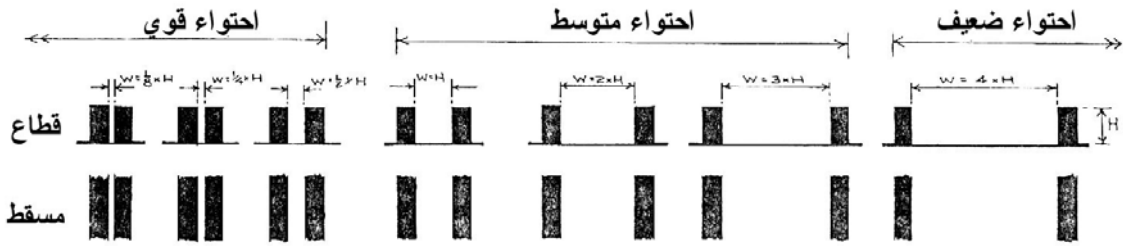

"Road Form,p110.":

(-)

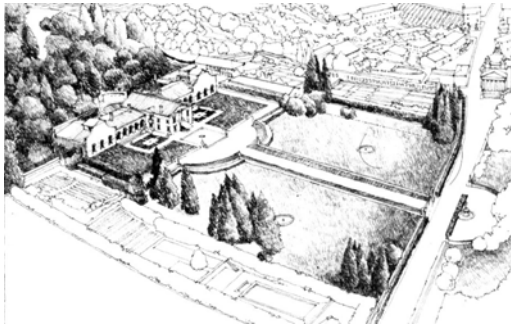

(-)

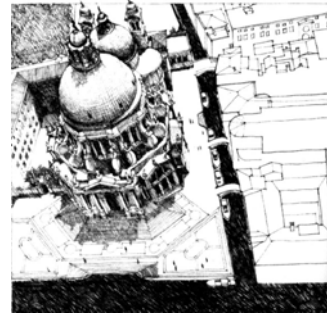

(-)





.Architecture- Form- Space &Order.":

:

•

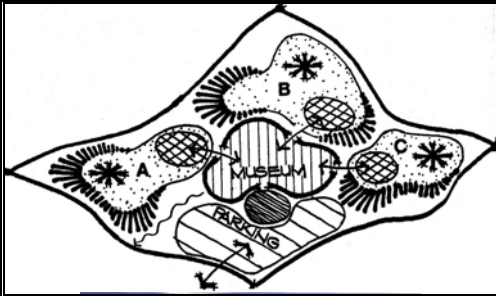
		◆
		◆
		◆
		◆
		◆
		◆
		◆

³⁰ Norman, K. Booth, "Basic Elements of Landscape Architectural Design", Waveland Press, Reissue edition, 1989.

		◆
		◆
		◆ ◆
		◆

"Road Form , Basic Elements of Landscape": (-) :

: :

()

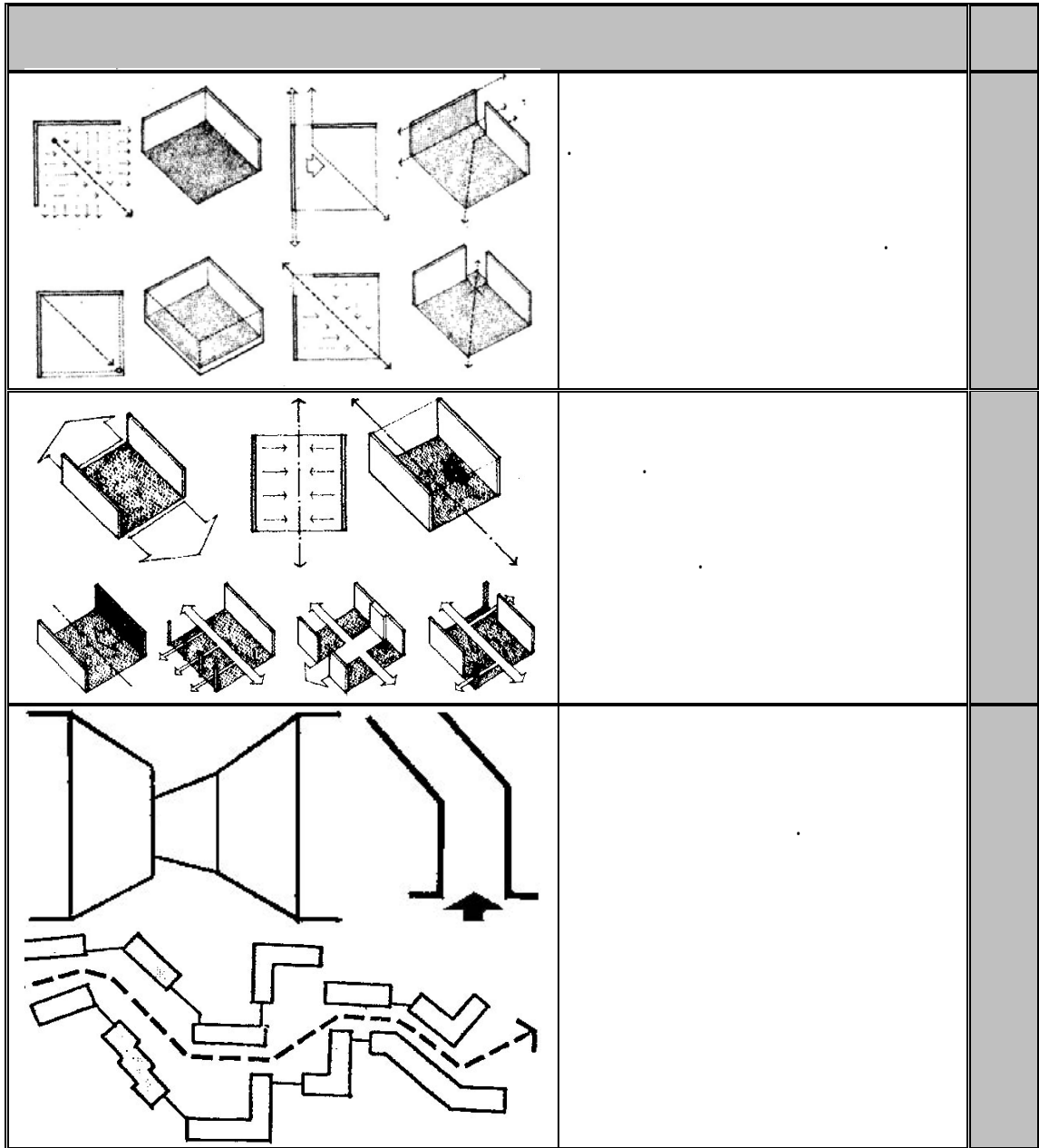

: ■

: ●

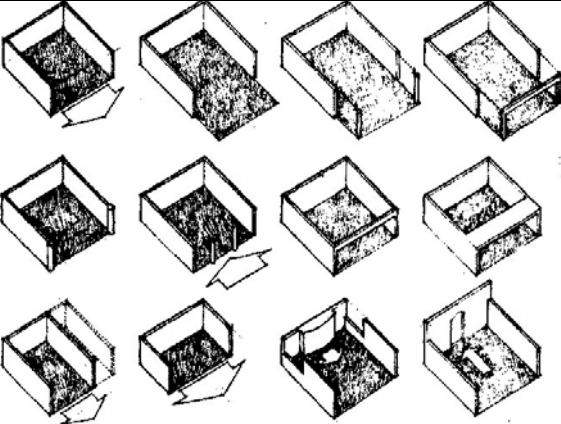

³¹ Ching, Francis: "**Architecture- Form- Space & Order**", Van Nostrand Reinhold Company, 1979, New York.

³² J. Mccluskey, "**Road form & Townscape**" ,Butterworth Architecture, 2nd edition, London, 1992, P112.

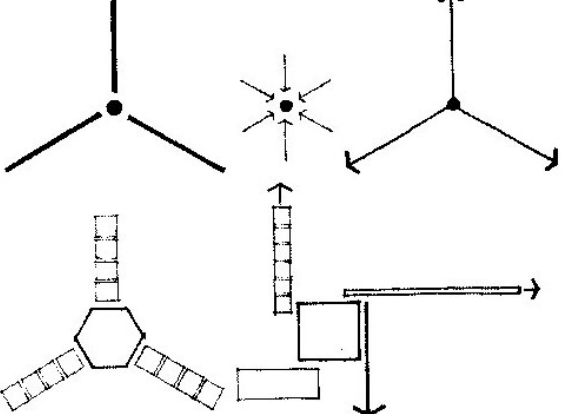
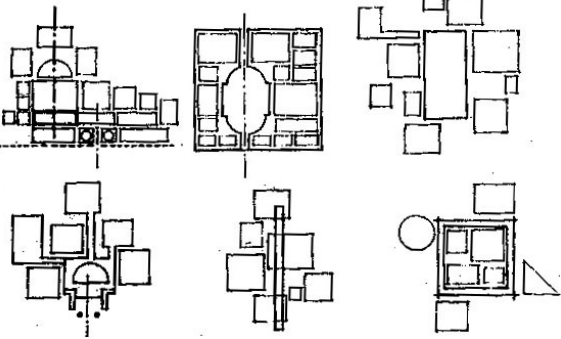
(-)

" Architecture- Form- Space & Order":

: •

	<ul style="list-style-type: none"> • • • 	
	<ul style="list-style-type: none"> • 	<p>)</p>
	<p>()</p> <ul style="list-style-type: none"> • 	
	<ul style="list-style-type: none"> • • 	
	<ul style="list-style-type: none"> • 	

(-)
"Road Form , Basic Elements of Landscape": :

() ()

: (

: :

..



(-)



(-)

: :

()



(-)



(-)

(... - -)

() ()

(.. - -)

·
:
(

·

· ...

: :

: :



(-)



(-)

: :

)

(- -

” ” 35

() ()

:

•

.

:

•

... ..

.

.

:

•

.

:

•

()

.

:

.

.

() ()

:() •

⋮
⋄ ⋄
⋄ ⋄
⋮ ⋮
()
()

⋮
⋄ ⋄
⋄ ⋄
⋮ ⋮

⋮ ⋮

() ()

:

-
-
-

)

(

:

:

:

(... / /)

(... / / /)

:

:

() ()

(... / /)

/)

(... /)
: - - - -

: (

: (

: (

: (

() ()

: - - -

-

-

:

: - - - -

.

: - - - -

.

: - - - -

:

- - - -

: - -
- (Emerging concepts in urban) : "Broadbent"
-
()

" " "

: "lynch"
*"The Essence Of Place Theory ...Lies In Understanding Cultural
And Human Characteristics Of Physical "*
(PLACE) (SPACE)

:() - - -
()

(_____) (_____)

(Cultural Anthropology)

:

:

(_____) : _____
_____ : (_____)

³ De blijk, H, "Human Geography: Culture, Society and Space", John Wiley & Sons, USA, 1982. 2
_____ 4

.

:

:

. - - -

:

:(Climate) (

.

:

. - - -

:

:

(

- -)

.(- - - - -)

:

:

(

.

:

(

() ()

:

· - - -

:

:

· - - -

(..)

:

· - - -

:

· - - -

)

(_____) (_____)

(...)

:

- - -

(city sense and city design)

(Sensational)

(Emotional)

(Intellectual)

:

•

•

:

- - - -

:

: (Tension)

-

(

-

-

-

-

8

9

¹⁰ Simonde, J. O., "Landscape Architecture", P.137.

(_____) (_____)

: (Relaxation) (

: (

:(Gaiety) (

:(Contemplation) (

:(Dynamic Action) (

:(Sublime Spiritual Awe) (

) (

(_____) (_____)

-(
:(Displeasure) (

-(
:(Pleasure) (

:

- - - -

"A good place is one which, in some way appropriate to the person and his culture, makes his aware of his community, his past, the web of life, and the universe of time and space in which these are contained"¹²

.(Legible)

¹¹ Rapoport, A. **"The meaning of the built environment: A nonverbal communication approach"**, Beverly Hills. Calif. Sage, (1982), P.515.

¹² Lynch, K. **"The image of the city"**, Cambridge MIT Press, USA, (1963), P.10.

() ()

)

.(

)

.(

¹³ Lynch, K. "**A theory of good city form**", Cambridge MIT Press, USA, (1981), P.142.

() ()

:

:

)

(

.(Latent Function)

) (Contest)

(

.(Contextual Meaning)

:(Identity) (

"

"

"

" ()

"

(American Heritage Dictionary)

"

" "

... "

... "

"

"

(Kevin Lynch)

"

"

¹⁵ الجابري، محمد عابد، "الموسوعة الفلسفية العربية"، معهد الإنماء العربي، ١٩٨٦، بيروت.

¹⁶ Salama, A.M., "**Human Factors in Environmental Design**", An introductory Approach to Architecture, The Anglo Egyptian bookshop, 1998, Cairo, Egypt

¹⁷ أبا الخيل، إبراهيم، "الخصوصية في العمارة العربية"، مجلة البناء السعودية، السنة التاسعة، ١٩٩٠، العدد ٥١، ص ٤٨-٥١.

¹⁸ Lynch, Kevin, "**A Theory of Good City Form**", The MIT Press. 1981, P.131.

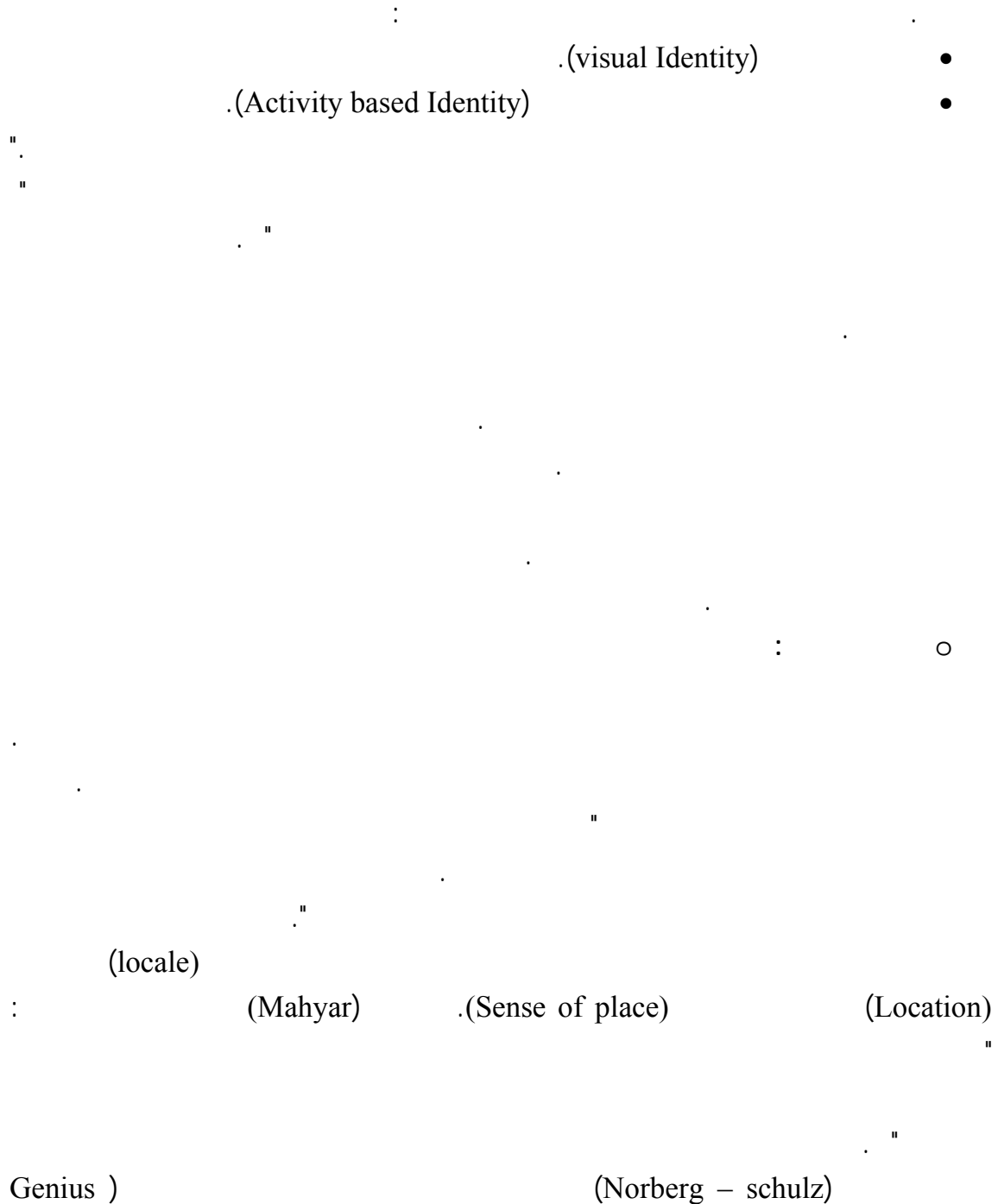

¹⁹ Salama, A.M, **Op. cit.** 1998, P 125.
²⁰ النعيم، مشاري عبد الله، "تحولات الهوية العمرانية: ثنائية الثقافة والتاريخ في العمارة الخليجية المعاصرة"، مجلة المستقبل العربي، عدد ٢٦٣، ٢٠٠١، بيروت، ص٩- ١٢٧.
²¹ Amin, M.K. **"Man, Environment and place Identity"**, An Environmental Design approach with Reference to the Egyptian Context, Unpublished PHD Thesis, Heriot-watt University, Edinburgh, England, 1994, P70.
²² Auf, A.M., **"Authenticity and the Sense of place in Urban Design"**, Journal of urban Design, Vol. 6, No. 1., 2001, P.P. 73-86.
²³ Mahyer, A., **"Non-place and Placelessness as Narratives of loss: rethinking the Notion of place"**, Journal of urban design, Vol. 4, No. 2, 1999, P.P. 179-194.

:
(Incidental outsiders)

Insiderness

(Vicarious insiderness)

incidental

(Behavioral

.outsiderness
insiderness)

(Empathetic

.Insiderness)

(Existential Insiderness)

." "
:
○

²⁸(Tuan) ²⁷(Relph) ²⁶(Buttimer)

²⁹(fabian, A.k., et al)

(Buttimer)

²⁶ Buttimer, A., "**Home, Reach, and the Sense of Place**", In A. Buttimer and D. Seamon (eds), *The Human Experience of Space*, 1980, Croom Helm, London, P.P. 166-87.

²⁷ Relph, E., **Op. Cit.**, 1976.

²⁸ Tuan, Yi-Fu., "**Space and Place: The Perspective of Experience**", 1977, Minneapolis: University of Minnesota Press.

²⁹ Fabian, A.K., "**Place-Identity: Physical World Socialization of the Self Readings in Environmental Psychology: Giving Places Meaning**", Groat, L., ed, 1995, Academic Press Limited, London, P.P. 87-115.

() ()

(Relph)

(Medieval Cities)

()

:(Placeless ness)

(Relph)

³³Hayden,

³².

(Relph) ³⁴Appleyard, & Jacobs ³⁵Houston)
(Non-place)

³⁶(Cullen)

³⁷(Lynch)

(Thomas More)

(Ebenezer Howard)

³⁰ Relph, E., "**The Instant Environment Machine and the Reclamation of Place**", Plenary Paper, "Place and Place Making Conference", Paper 85, 1985, Melbourne, Australia.

³¹ Amin, M.K., **Op. Cit.**, 1994, P 81.

³² Relph, E., **Op. Cit.**, 1976.

³³ Hayden, D., "**The Power of Place: Urban Landscape as public History**", MA, 1995, MIT Press, Cambridge.

³⁴ Appleyard, D. & Jacobs, A., "**Toward an Urban Design Manifesto: a Prologue**", 1987, Journal of the American Planning Association, 53 (1), P.P.112-120.

³⁵ Houston, J.M., "**The Concepts of Place and Land in the Judeo-Christian tradition**", in Humanistic Geography: Prospects and Problems, 1978, Ley, D.L. & Samuels, M.S., eds, IL, Maaroufa Press, Chicago. P.P. 224-237.

³⁶ Cullen, G., "**The Concise Townscape**", The Architectural Press, 1961, London.

³⁷ Lynch, K., 1981, **op. cit.**

³⁸ **Ibid**, p64.

() () ()

(Geddes) (geddes patirick) (Eutopia)
Idealized-) (Preconocived Plan

:

:

:

:

(Perception)

:

:

○

:

:

:

:

:

:

:

:

●

●

●

³⁹ Hough, M., "Out of Place, Restoring Identity to the Regional Landscape", Yale University Press, 1990, New Haven and London. P.P. 60-6 1.

⁴⁰ "مرغني، عزت عبد المنعم: "العوامل المؤثرة على اختيار الشكل في العمارة- دراسة تحليليه بهدف تقييم أداء الشكل في العمارة المصرية المعاصرة". رسالة ماجستير، قسم الهندسة المعمارية، جامعة أسيوط، ١٩٩٢، ص ٤٣.

⁴² Lynch, Kevin: "The Image of The City", The MIT, press, Massachusetts, 1960, P. 6.

⁴³ Lynch, Kevin: "Op. Cit.", P. 4.

(_____) (_____)

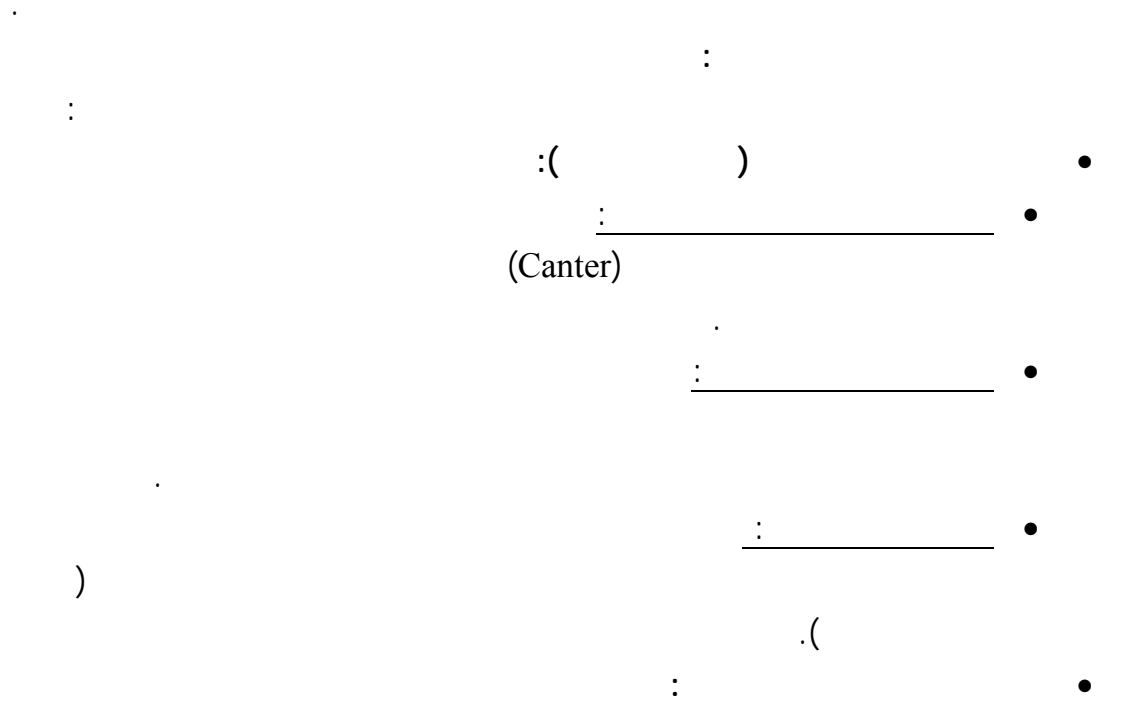

(Lynch)

(Imageability)

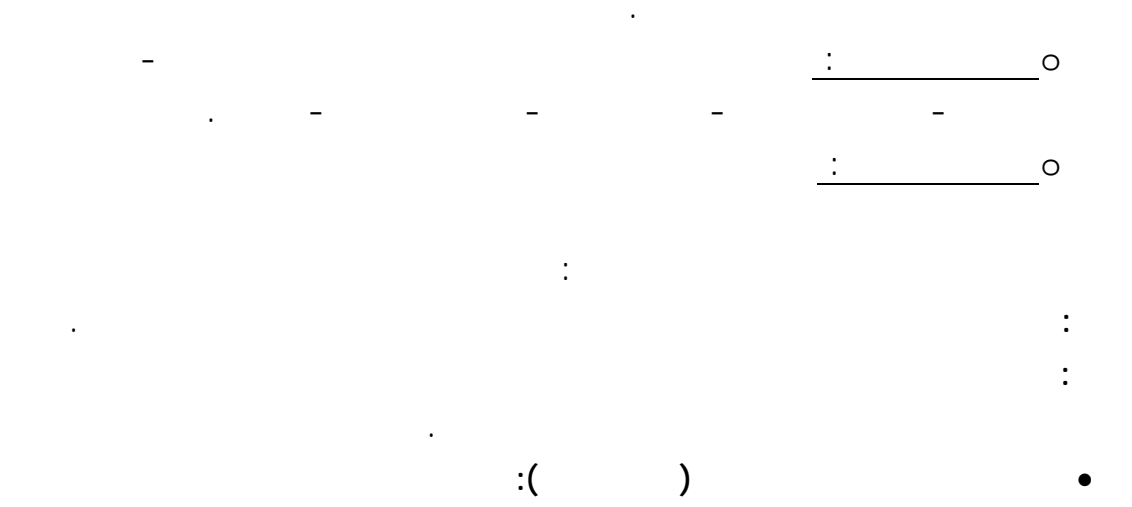

⁴⁴ Lynch, Kevin: "The Image of The City", The MIT, press, Massachusetts, 1960, P. 9.

(_____) (_____)

:

: _____ ○

: _____ ○

: _____ ○

: _____ ○

: ●

:

: **(Perceptual Meaning)** ○

(Physical Context)

(&Locational Attributes)

)

: **(Associational Meaning)** ○

)

(

()

:(Responsive Meaning) ○

:(Prescriptive) ○

-

" "

-

)

.(

()

:

)

.(

()

(_____) (_____)

:

- - -

_____ :

()

_____ : _____

:

- - -

.()

•

.()

•

•

:

:

(

:

:

•

:

•

:

•

_____ " _____ "

() ()

:() ()
:

•
•

• • •
• • •
" : •

:() ()

• - - - -
:
(Social Context)

:(Necessary Activities) / ()

:(Optional Activities) / ()

)
(

:(Social Activities) (

(-) .

●	●	
●	●	
●	●	()

(-)

Gehl, Jan, "Life Between Buildings", Van Nostrand Reinhold, 1987, New York, P. 13.:

: - - -

: . - - -

: : (

⁴⁸ Gehl, Jan, "Life Between Buildings", Van Nostrand Reinhold Company, 1987, New York, P.P. 11-13.

⁴⁹ Cooper, Clare, "People Places", 2nd edition, John Wiley & Sons, Canada, (1998), P.25.

(_____) (_____)

.
:

... C.D.ROM : (

.
○ . ○ . ○
○ . ○ . ○
:() (

: . - - -

)
:
(: (

Kallman,) (Court Street) (Cambridge)

⁵¹ Carr, S. Francis, M. "Public Space", Cambridge University Press, USA, (1995), P. 92. 50

() (Mckinnel

(-)

(-)



(-)

(Stephen Carr, Elizabeth March): "Public Space.":



(-)

"Public Space.":



(-)

(Stephen Carr): "Public Space.":

: (

⁵² Carr, S. Francis, M. "Public Space", Cambridge University Press, USA, (1995), P. 88.

⁵³ Carr, S. Francis, M. "Public Space", Cambridge University Press, USA, (1995), P. 98.

() ()

: (

(Hanna\ Olin) () (Fifth avenue) () (Thomas Hastings)

.(-)



(-)

(Mark Francis): "Public Space.":

:



(-)

(Stephen Carr): "Public Space.":

(

) (High-tech)

.(

(- -)

⁵⁴ Whyte, W.H. "The Social life of small urban spaces", Washington, D.C.: the conservation foundation, (1980), P. 13.

⁵⁵ Carr, S. Francis, M. "Public Space", Cambridge University Press, USA, (1995), P. 108.

⁵⁶ Global Architecture. "Centre Georges Pompidou", Tokyo, (1977), P. 3.



(-)
(Leanne Rivlin): " Public Space.":



(-)
(Stephen Carr): " Public Space.":
:

: - - - -
()
:
:(Access) (

⁵⁷ Lynch, K. "A theory of good city form", Cambridge MIT Press, USA, (1981).

(-) (-)

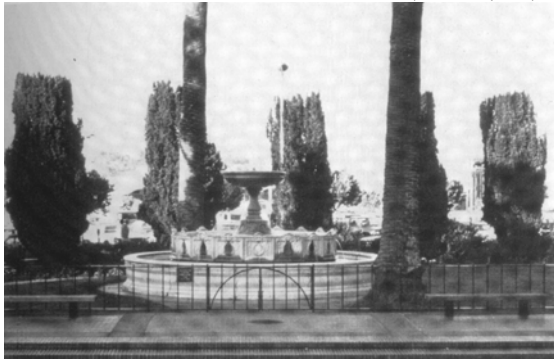

(-)
(Mark Francis): "Public Space."
:(Freedom of action)

(-)
(Elizabeth March): "Public Space."
(

The right of use and "

"action

(-)



) (-)
(Elizabeth March): "Public Space.":

(-)
(Stephen Carr): "Public Space.":
:(Claim) (

⁵⁸ Carr, S. Francis, M. "Public Space", Cambridge University Press, USA, (1995), P.139.

⁵⁹ Carr, S. Francis, M. "Public Space", Cambridge University Press, USA, (1995), P.152.

() ()

()

:(Change) (

:

:



(-)



(-)

(Stephen Carr): " Public Space.":

(Mark Francis): " Public Space.":

:(Ownership) (

⁶⁰ Lindey, N. "Drawing Socio-economic lines in central park", Landscape Architecture, (1977), P.515.

⁶¹ Lynch, K. "A theory of good city form", Cambridge MIT Press, USA, (1981), P.171.

(_____): (_____)

: _____

*(_____) (_____)

:

: _____ ●

: ○

: ○

: ○

: ○

: ○

: _____ ●

: ○

.
:
○

.
:
○

.
:
○

.
:
○

)

(

)

.(

_____ *

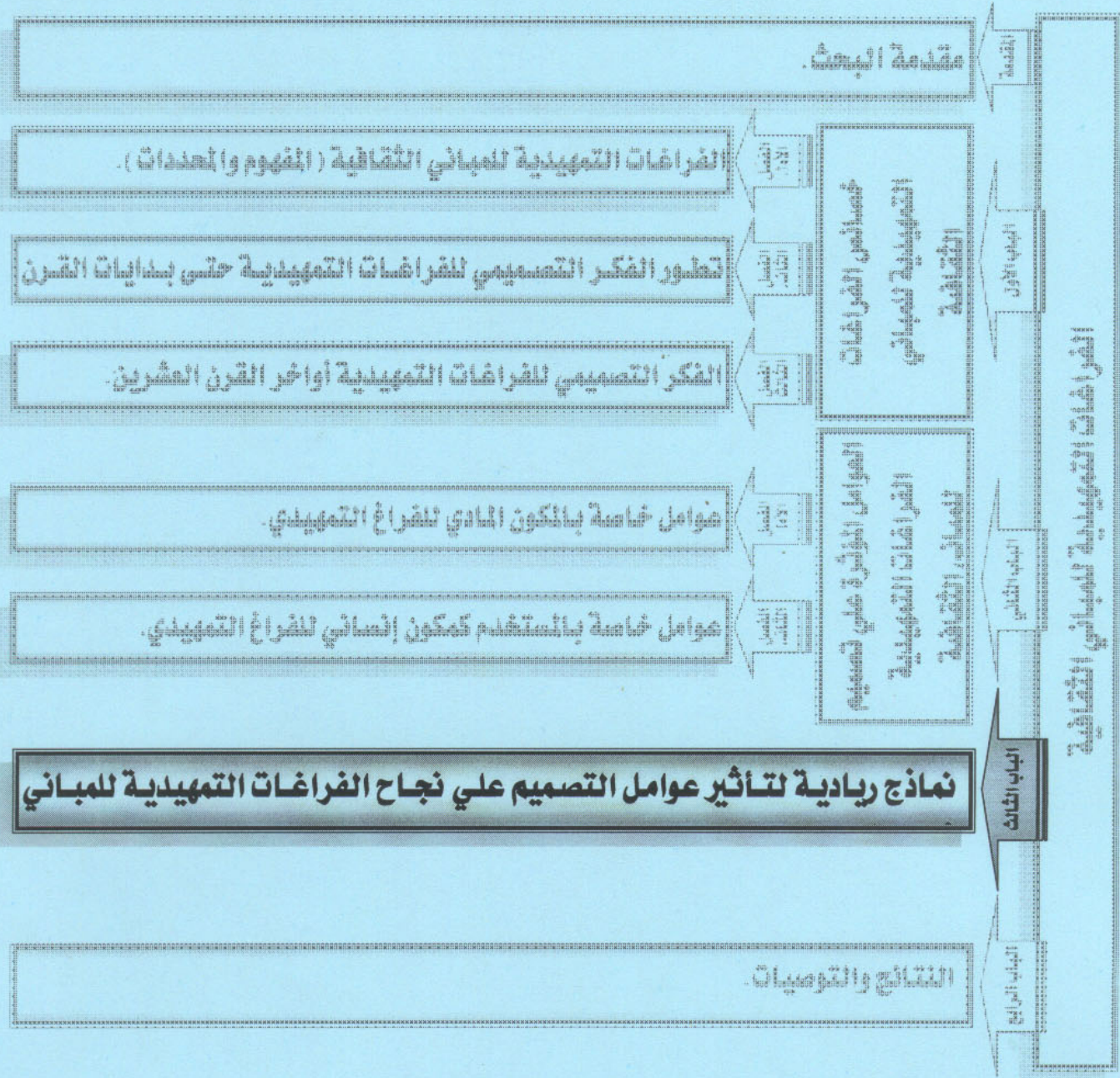

الباب الثالث: نماذج ريادية لتأثير عوامل التصميم علي أداء الفراغ التمهيدي

أسس اختيار الأمثلة التحليلية محل الدراسة.

- ٣-١- مركز بومبيدو الثقافي (Centre Pompidou) - باريس - فرنسا.
- ٣-٢- امتداد متحف اللوفر (Louvre Pyramid) _ باريس _ فرنسا.
- ٣-٣- حديقة الأطفال الثقافية (حديقة الحوض المرصود) _ القاهرة _ مصر.
- ٣-٤- متحف النوبة (Nubian Museum) - أسوان - مصر.
- ٣-٥- مكتبة الإسكندرية (Bibliotheca Alexandrina) _ الإسكندرية _ مصر.

خلاصة الباب الثالث.

: -

-
()

- :
-
-
-
-
-
- *
-

-

:

- (Centre Pompidou) - -

- (Louvre Pyramid) - -

- (Plase Des Terroux) - -

- () - -

- (Nubian Museum) - -

- (Bibliotheca Alexandrina) - -

(-)

()		
()		
()		
()		
()		
()		
()		
()		
()		
()		
()		
()		
()		

: - **-(Centre Pompidou)** - -

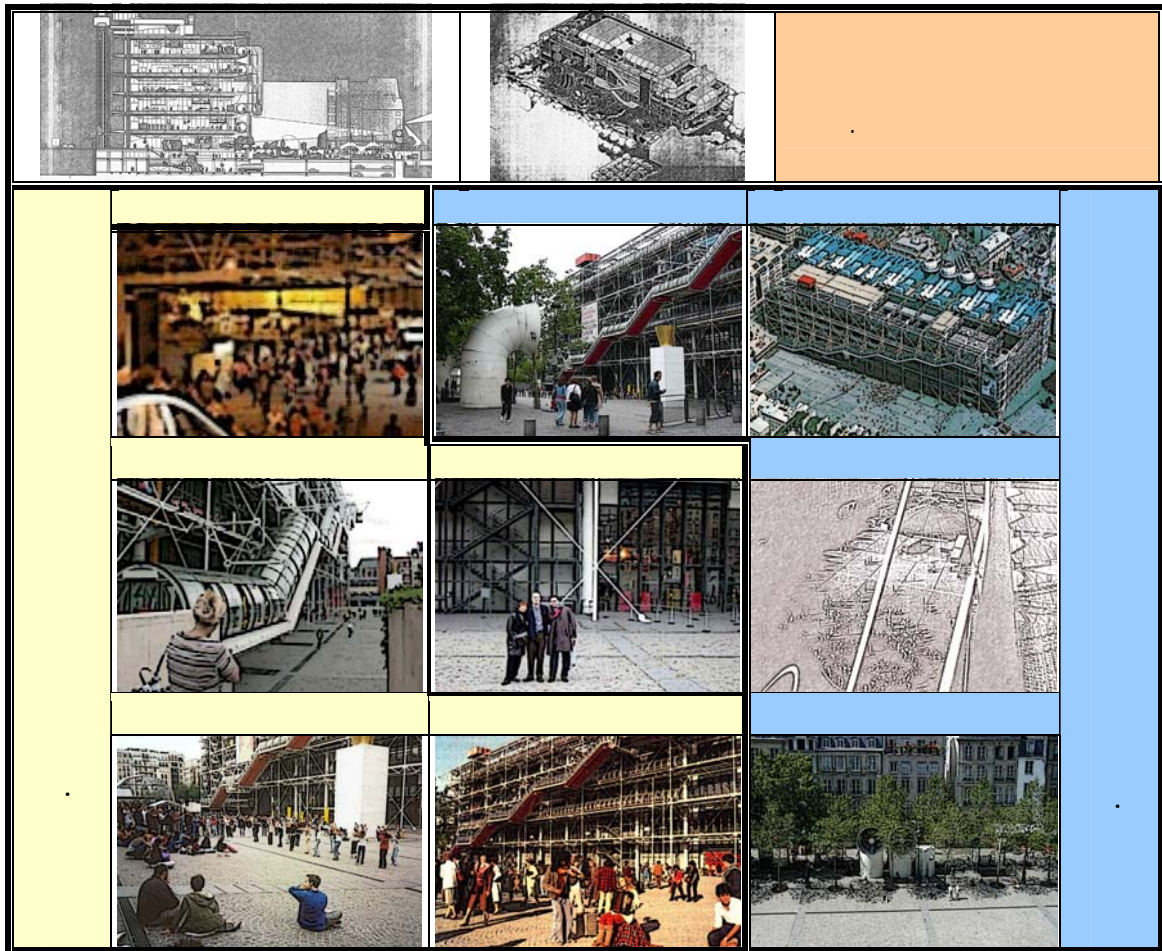

- (Centre Pompidou)

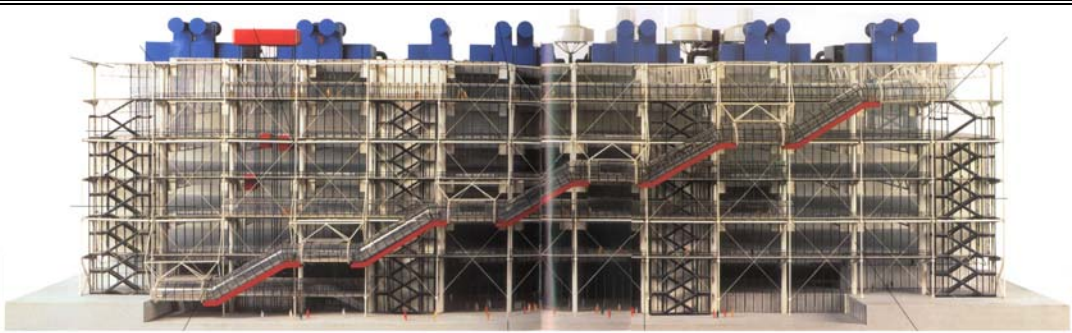
- (Centre Pompidou) (-)	
(Ove Arup) () () :	:
() () () () ()	
	





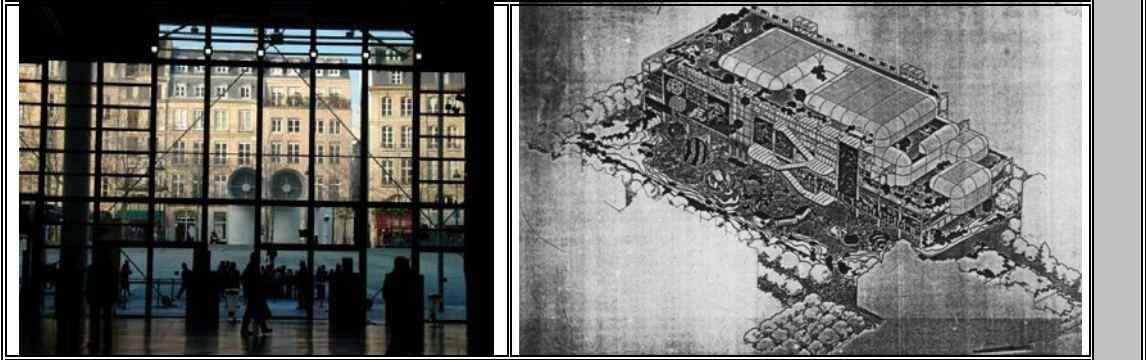
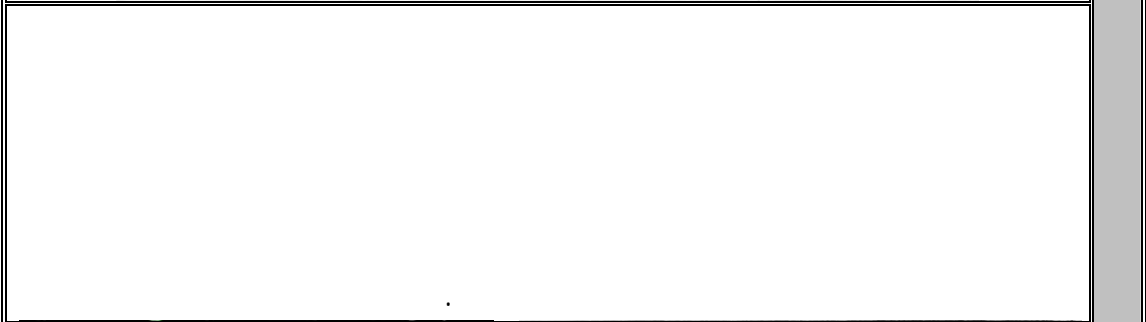
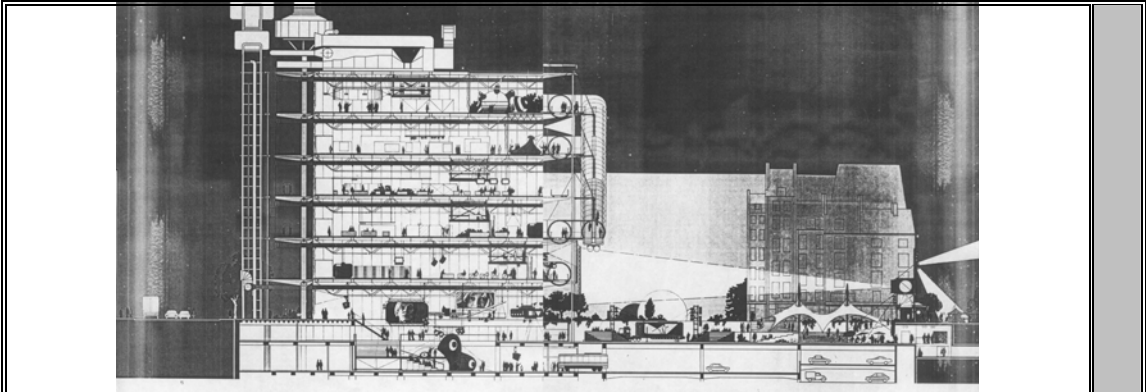

¹ <http://www.cnac-gp.fr/pompidou/Communication.nsf>

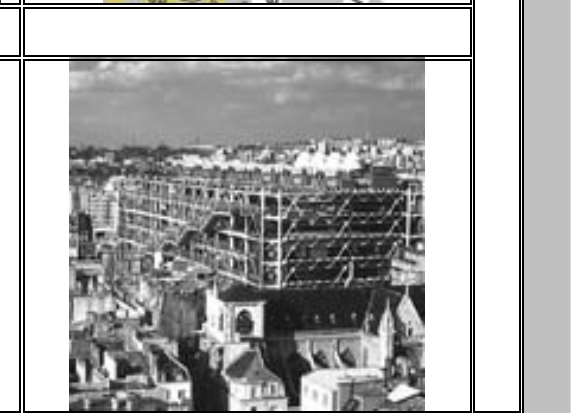
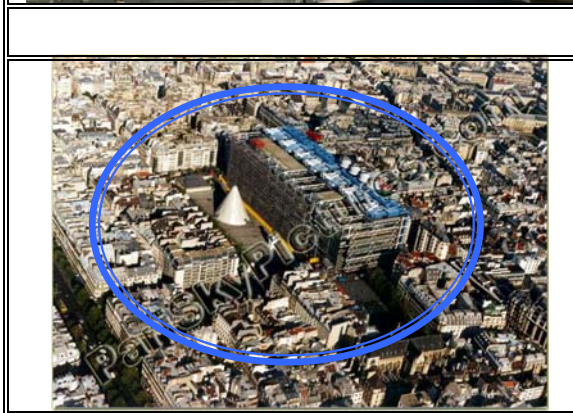
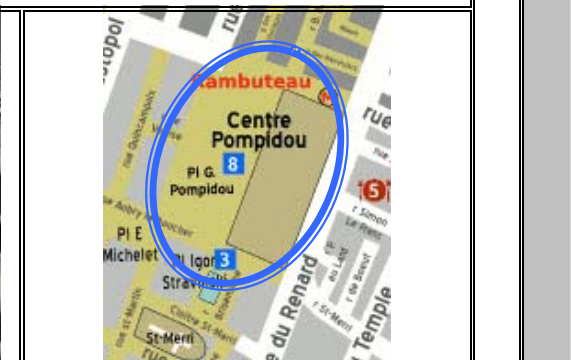
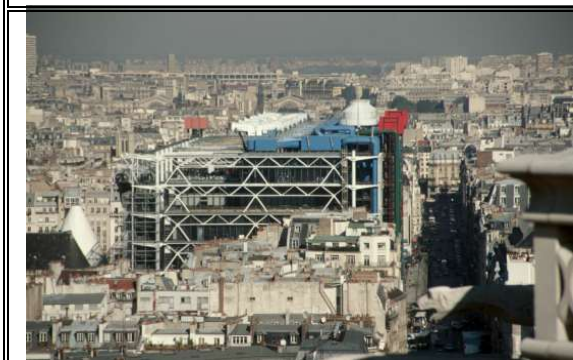
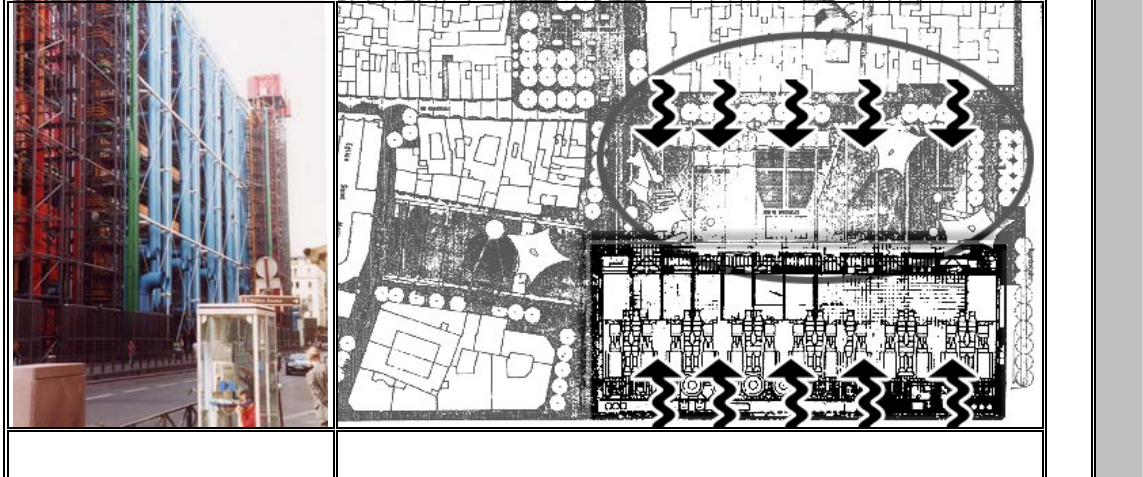
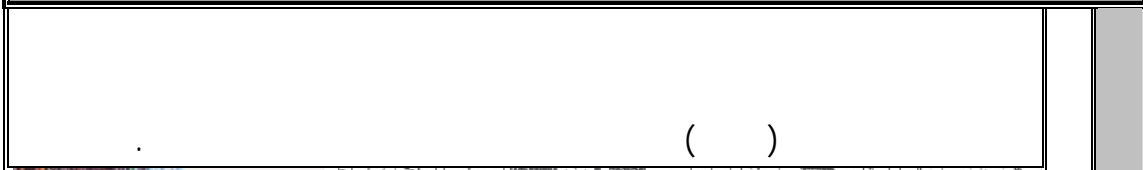

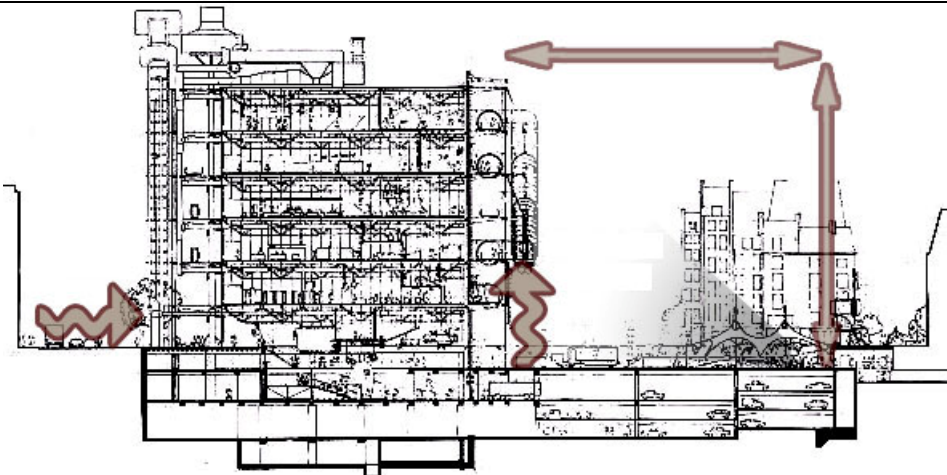

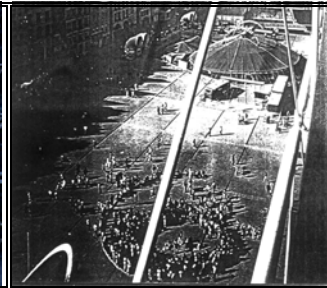

Rowell, K., "**Richard Rogers Complete Works**", Phaidon Press, UK,(1999), P. .
Steele, J., "**Architecture Today**", Phaidon Press, USA,(1997), P.70.
Carr, S. Francis, M. "**Public Space**", Cambridge University Press, USA, (1995), P.111-113.
Stevenson, Neil, "**Annotated Guides Architecture**" DK publishing, Italy, 1984, p.96.
Google Earth.



()



 <p>An architectural section drawing of a multi-story building. The drawing shows the internal structure, including floors, walls, and a central core. Red arrows are overlaid on the drawing: a horizontal arrow at the top, a vertical arrow on the right side, and two wavy arrows on the left side pointing towards the building's facade.</p>	<p>()</p>		
 <p>A photograph showing a building under construction. The structure is heavily scaffolded. A prominent red staircase is visible, extending from the ground level up to an upper floor. A large crowd of people is gathered in the foreground, some sitting on the ground, others standing.</p>	 <p>A photograph of a building under construction, similar to the one in the previous image. It features a red staircase and a crowd of people. The building's facade is made of glass and metal. A watermark "GreatBuildings.com" is visible in the bottom right corner.</p>	<p>()</p>	
<p>()</p>			
 <p>A photograph of a building under construction, showing a red staircase and a crowd of people.</p>	 <p>A photograph of a building under construction, showing a red staircase and a crowd of people.</p>	 <p>A photograph of a building under construction, showing a red staircase and a crowd of people.</p>	<p>()</p>
<p>()</p>			

			()
			
			() ()
			

() (,) ()



.



.



.

.



()

		

() () ()		
() (,) (,) ()		
:		
	:	
	:	
	:	
		
		() ()

: _ _ (Louvre Pyramid) - -

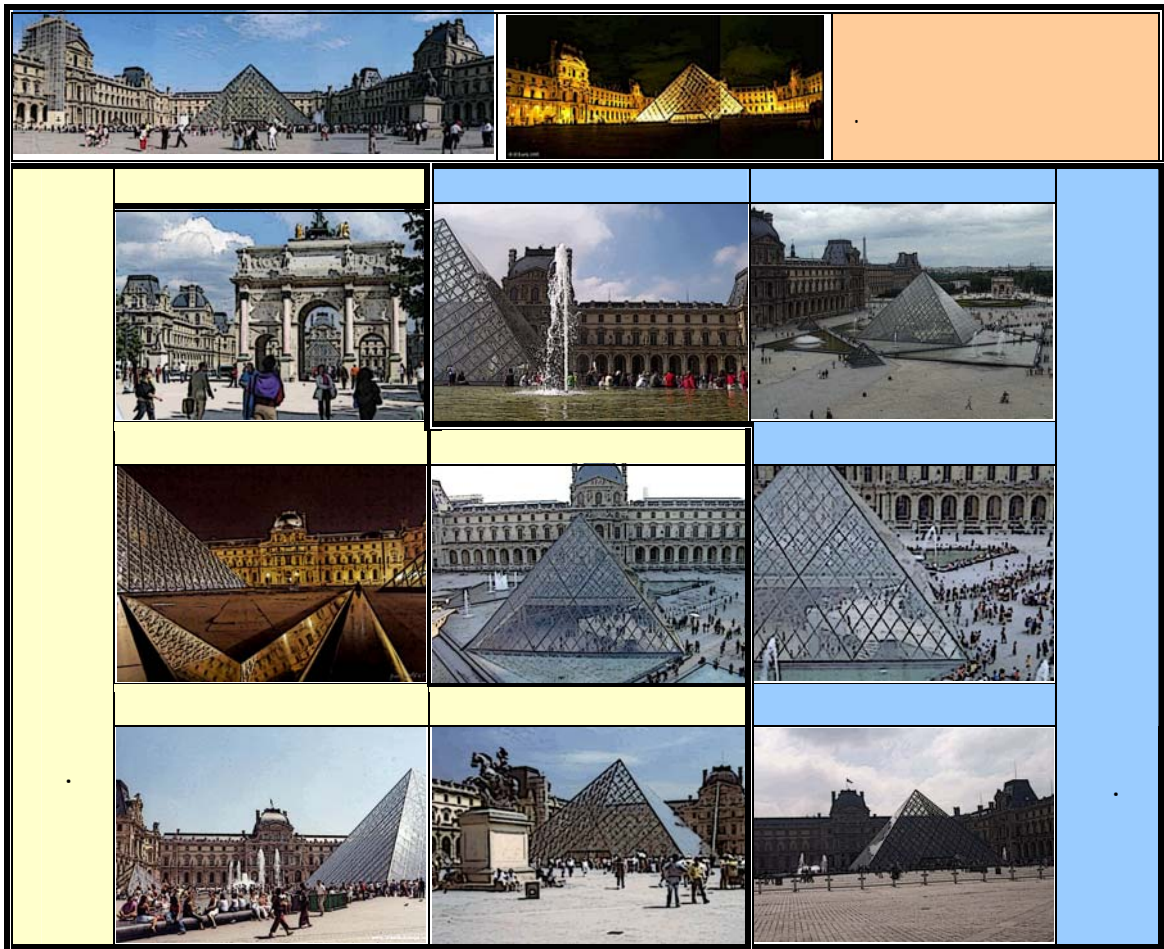

_ _ (Louvre Pyramid) (-)

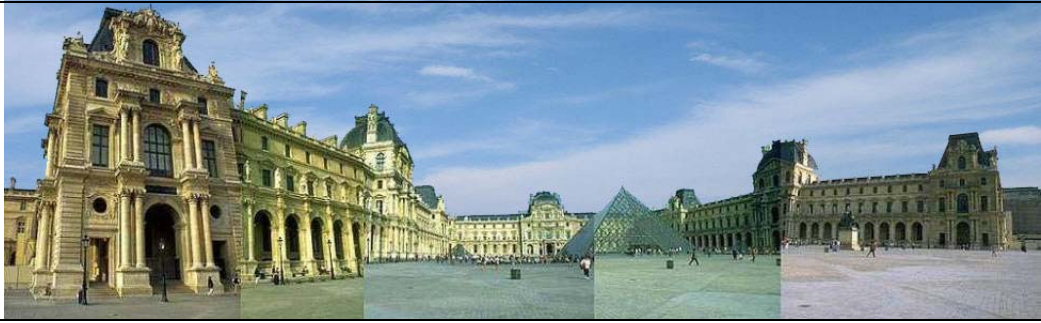



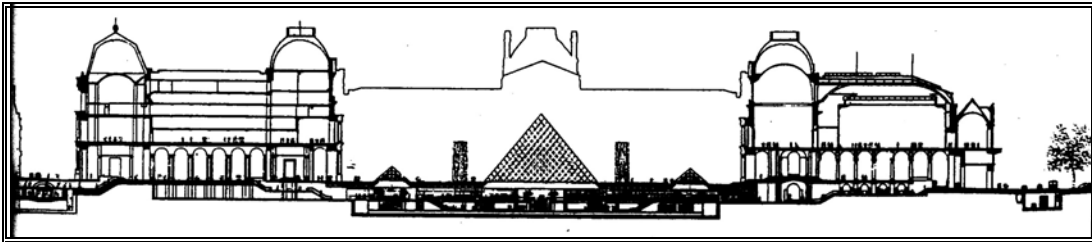

(Louvre Pyramid)		(-)
Ieoh Ming Pie (I.M. Pie)	:	
	:	
Philippe)	(Italian Renaissance Style)	(Auguste
	(I.M. Pie.)	
	()	
		
	(I.M. Pie)	

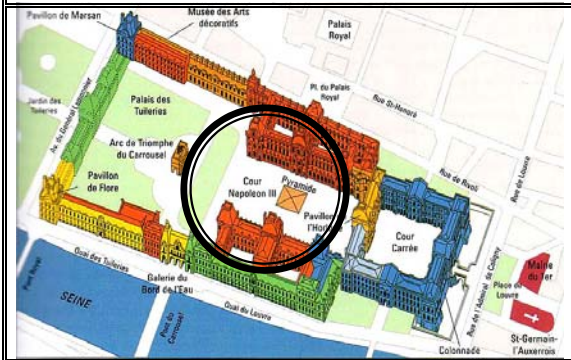
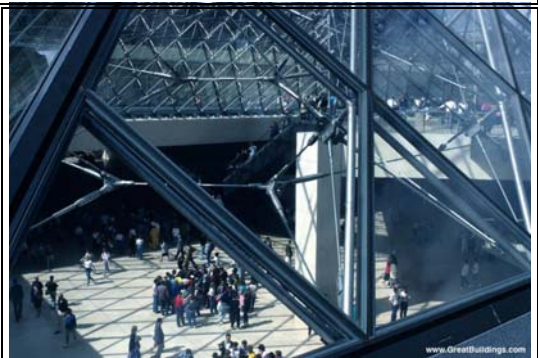
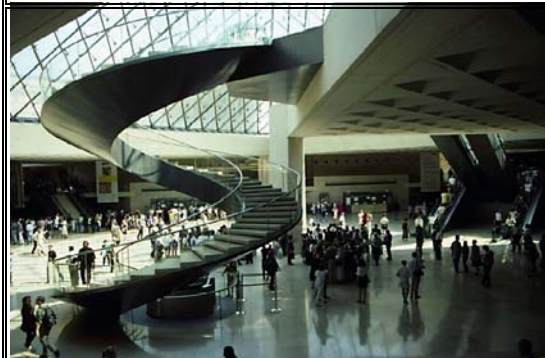
² http://www.louvre.fr/llv/commun/home_flash.jsp
http://www.greatbuildings.com/buildings/Pyramide_du_Louvre.html
<http://classes.uleth.ca/200103/art2850b/louvre.html>



() ()



		
		
		()

()

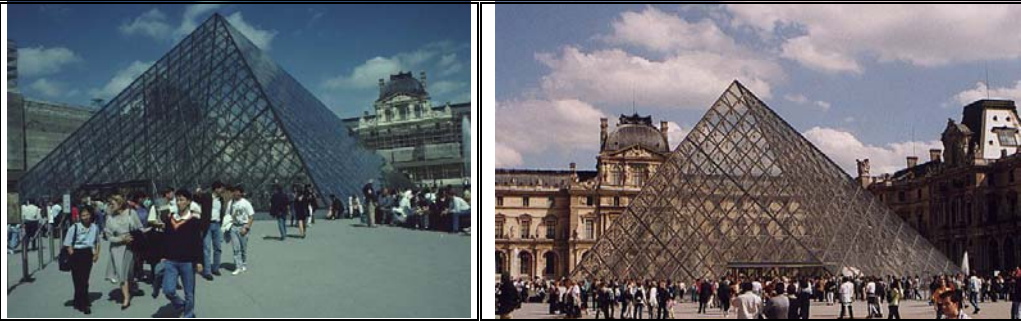
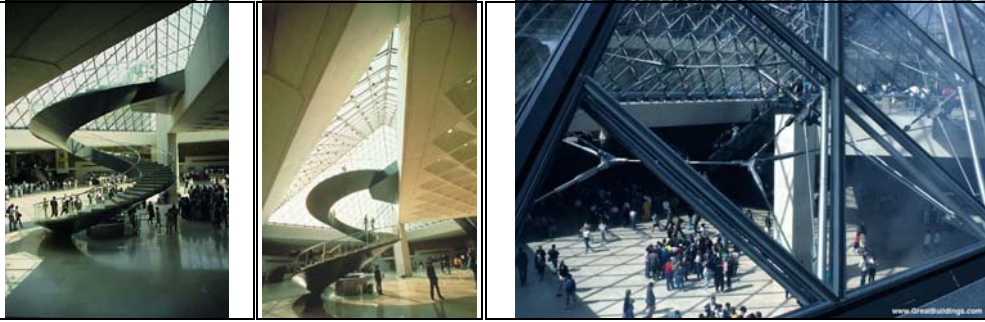

(U)



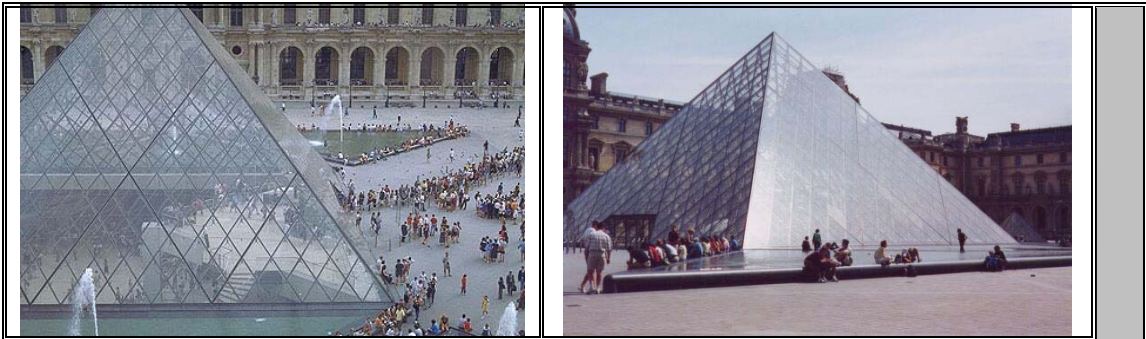

:
:
:
:
-
-

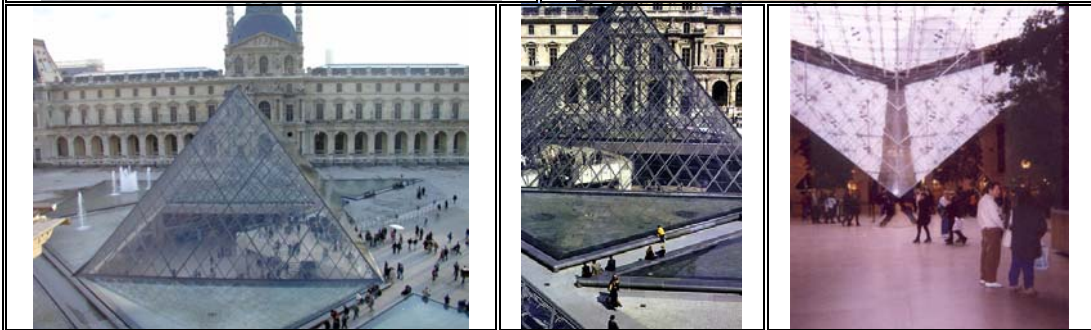



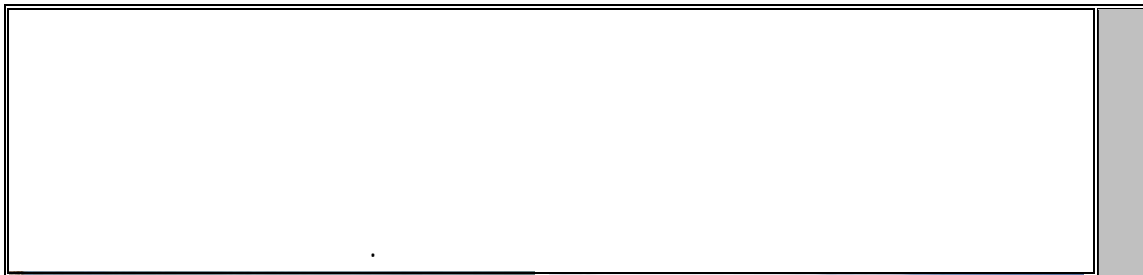

() () ()



: - - (Place Des Teroux) - -

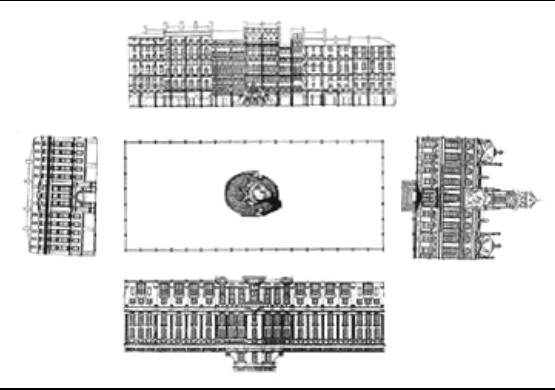
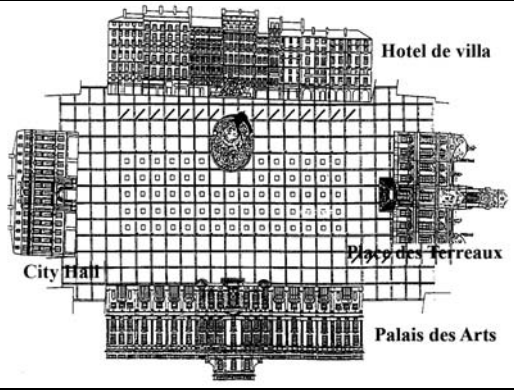

- - (Place des Terraux)

- (Place des Terraux) (-)	
(Daniel Buren) & (Christian Drevet)	
:	
:	
(City Hall) (Hotel de Ville)	(Place Des Terraux) (Palais des Arts)
	
	
	

³ Francisco A. Cerver, "**Redesigning City Squares and Plazas**", Arco Hearst Books, New York, 1997, Pp.8-17.
 Carles Broto, "**Urbanism**", links international, Spain, 1995.
 Archives Municipales de Lyon By: J. Gastineau.
 Google Earth.
<http://www.art-entreprise.com/html/placterr.htm>
<http://www.highwaygold.co.uk/regional/europe/france/lyons/terreaux/>
<http://www.arksite.dk/wm142098>
<http://www.student.tue.nl/t/b.j.h.muskens/urbanform.htm>
<http://www.carfree.com/design/sqlg150.html>
http://www.lyon-photos.com/diaporama/index_terreaux_7.htm
<http://lyon-passionnement.com/decouverte/terreaux/photos.htm>

(Changing everything touching nothing)



-

-

(, * ,)

-

-

:

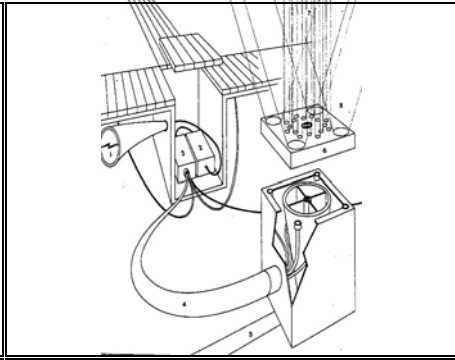

()

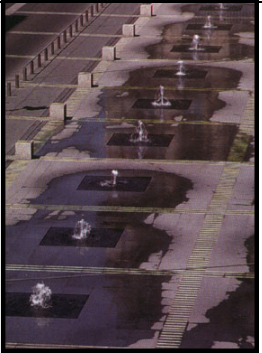
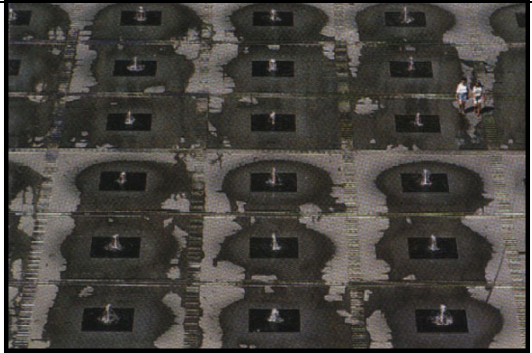

()



()

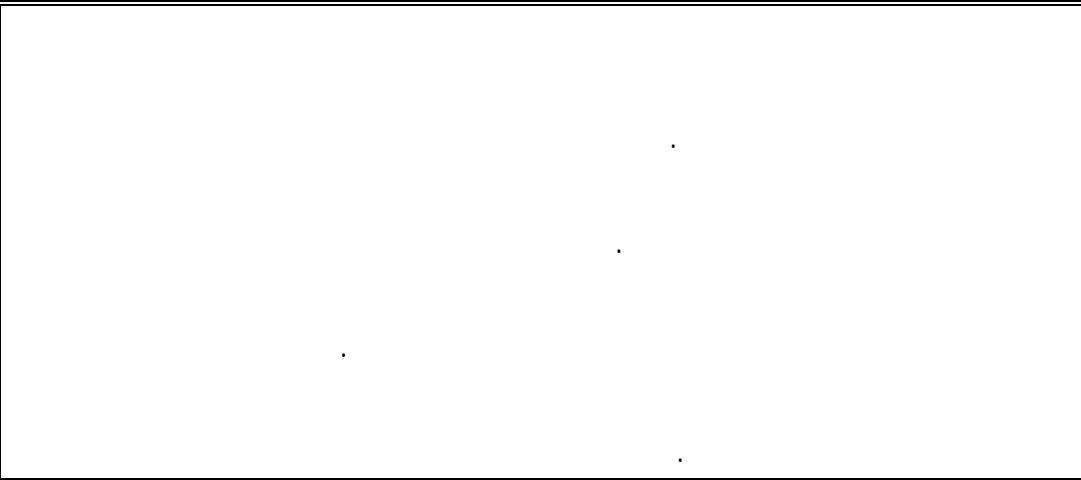

:(Palais des Arts)

-
-
-
-

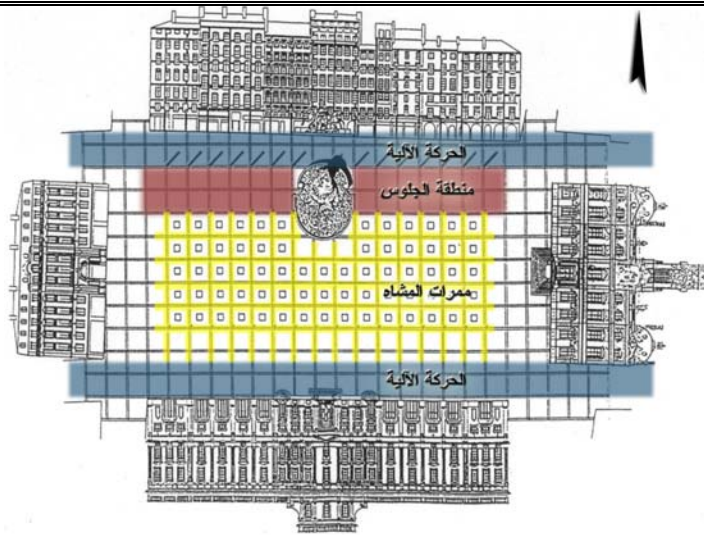



- -

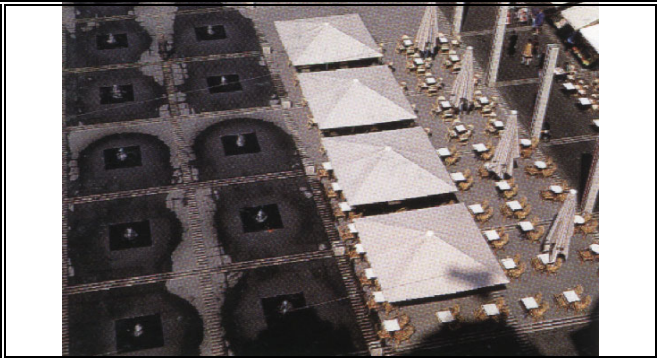

()

()

()

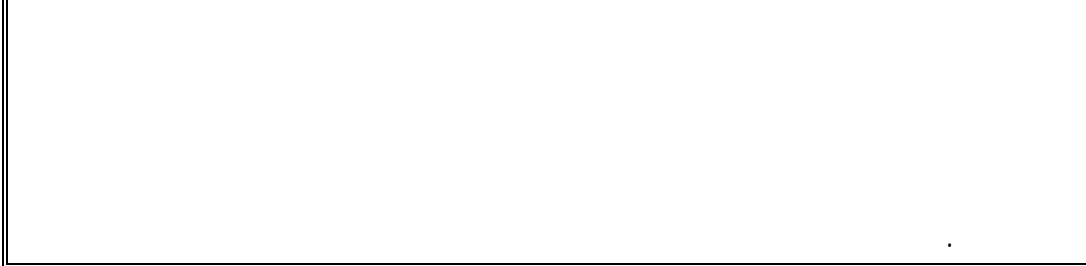
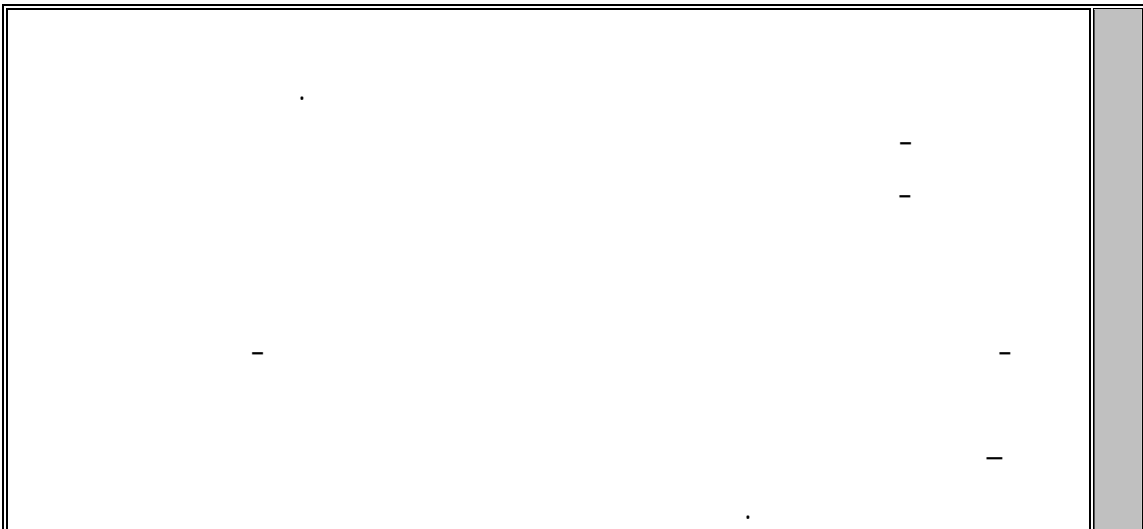

-
- ()
(, * ,) (, * ,)

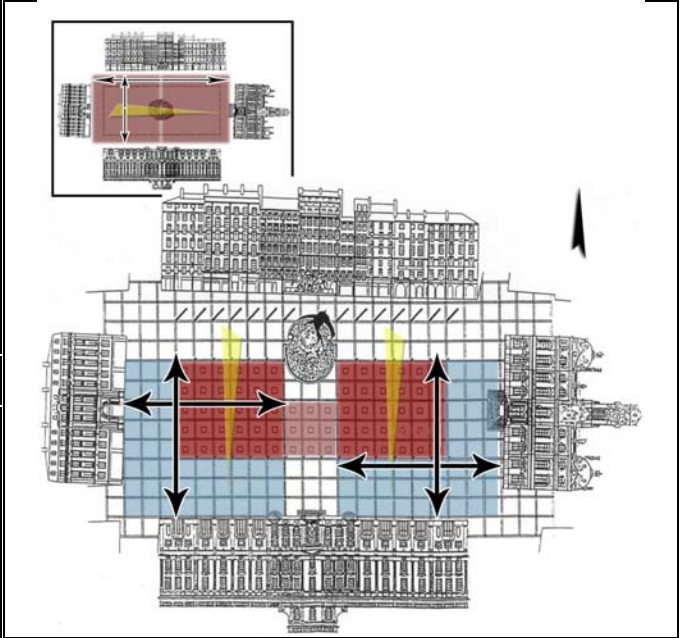

()

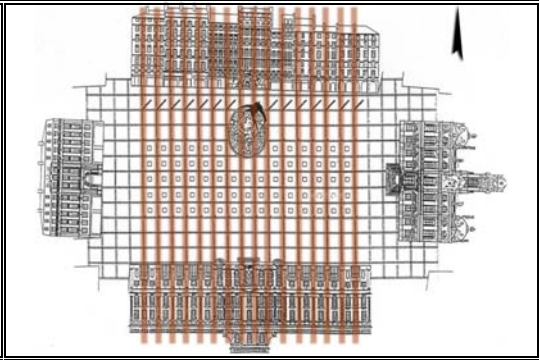
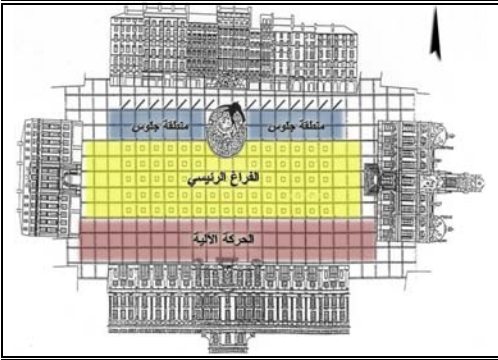

()



(Fontaine Bartholdi)

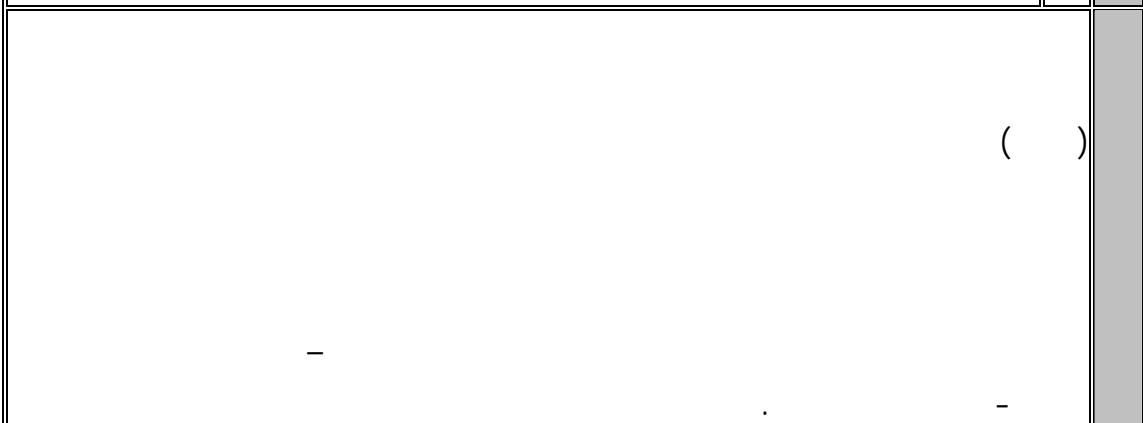

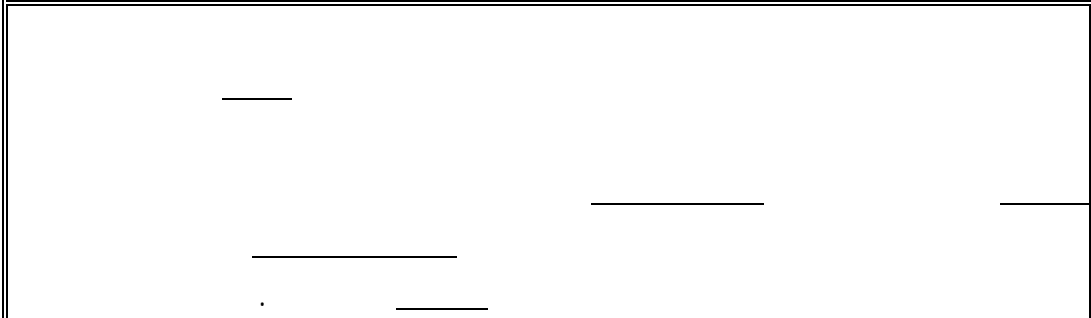
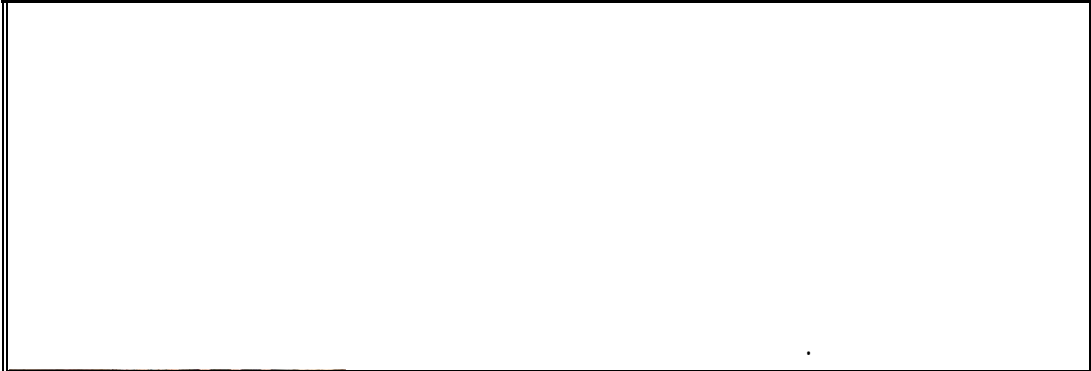

() ()

:

:

:

:



) ()

(

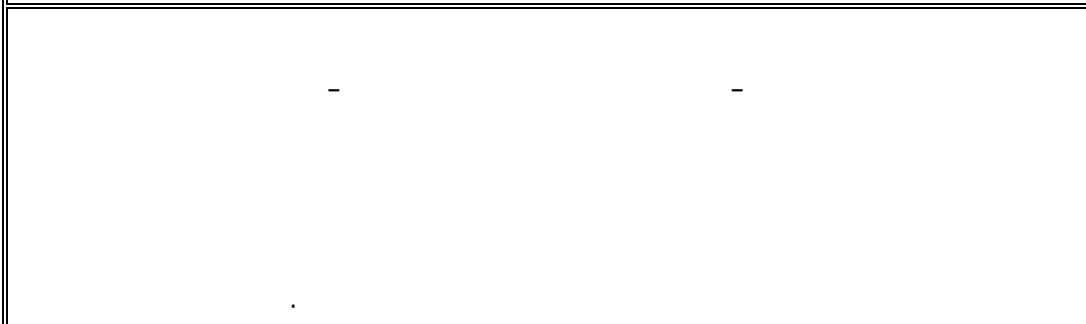
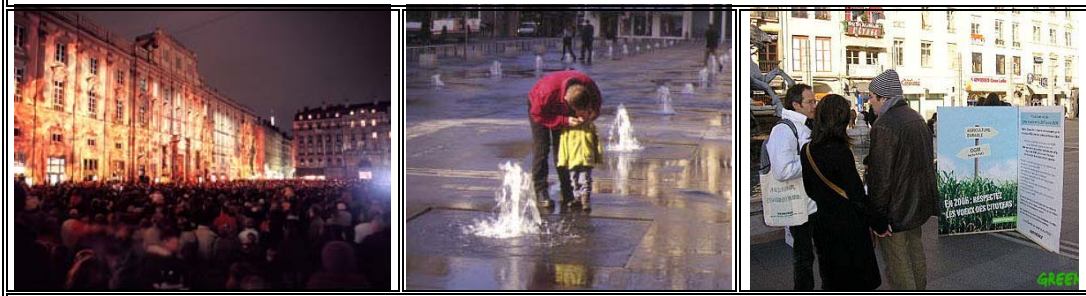
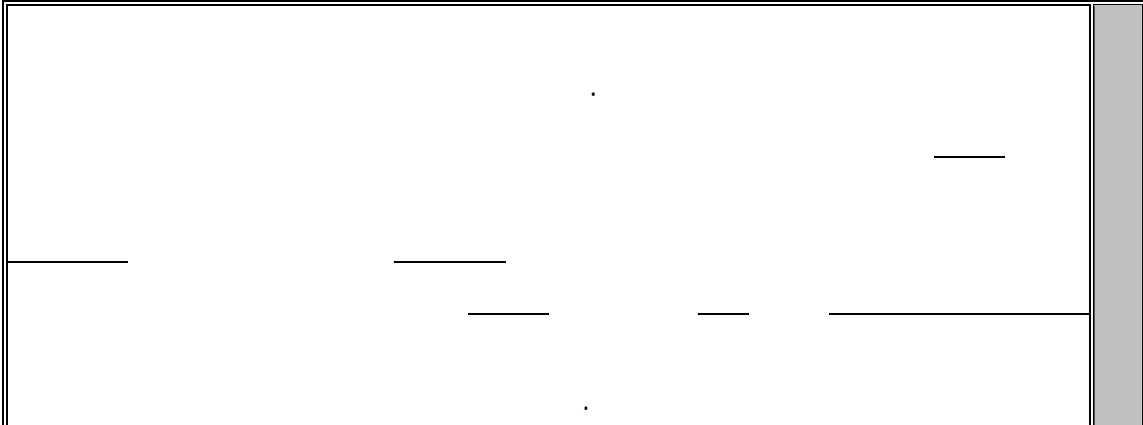



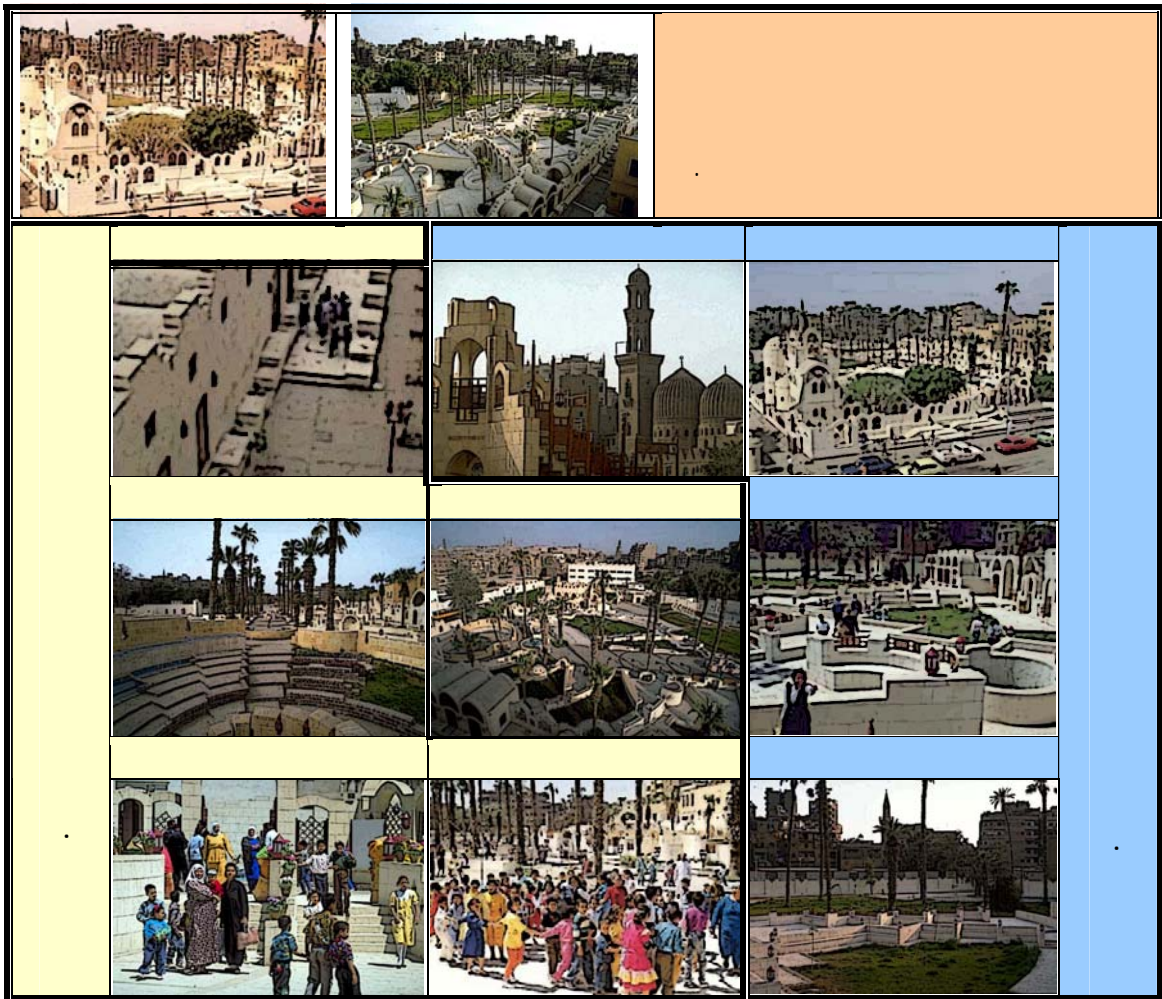

() ()

: - - () - -





- - () (-)

. _ _ () (-)	
	/.
	:
	
	

⁴ http://archnet.org/library/sites/one-site.tcl?site_id=1022
http://archnet.org/library/documents/one-document.tcl?document_id=4466
Akbar, Jamel, " **Technical review of Cultural Park for Children** ", Aga Khan Award for Architecture, 1992.
Aga Khan Award for Architecture , "**Project summary of Cultural Park for Children**", 1992.
Abdel Halim, Halim, " El-Houd El Marsoud", MIMAR 8: Architecture in Development,1983.
Google Earth.

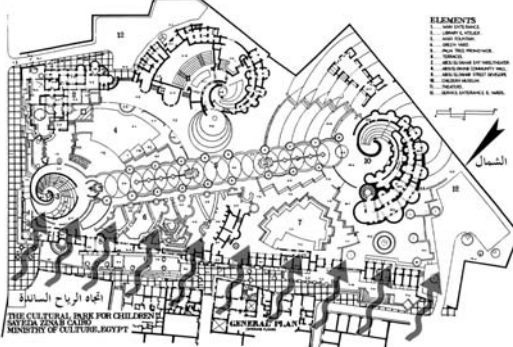



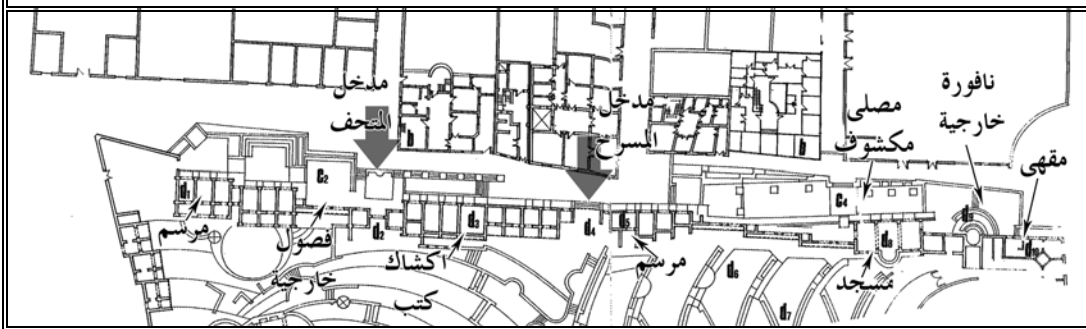
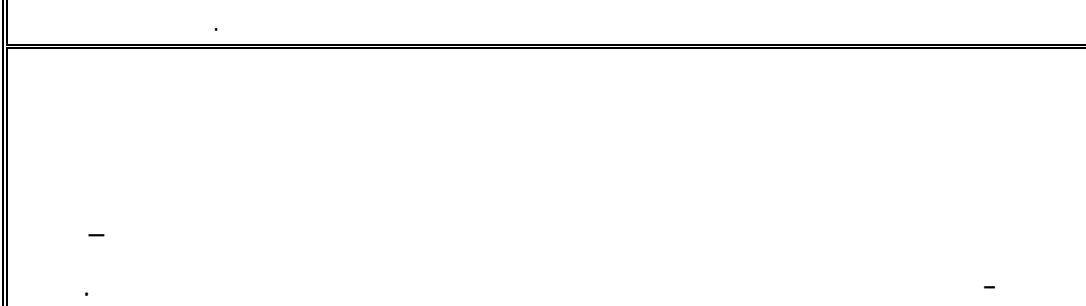
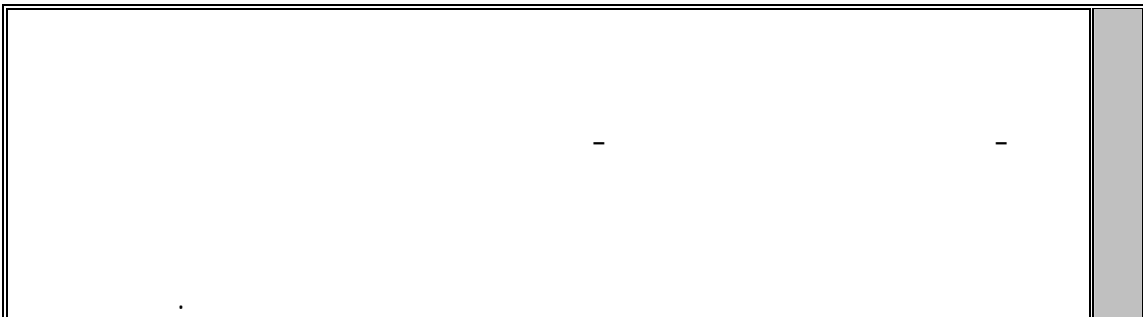

:

() :

()

:

()

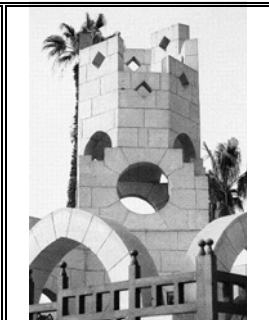
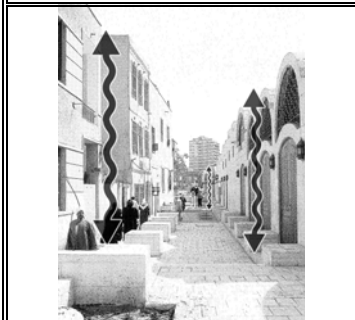
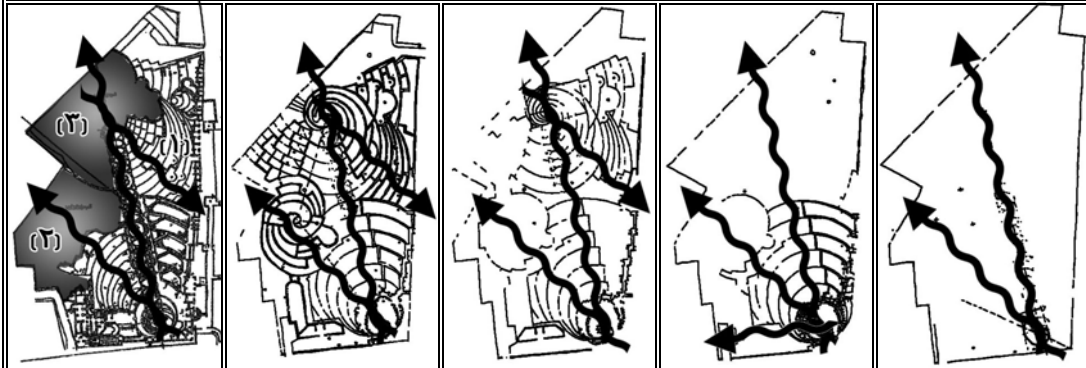

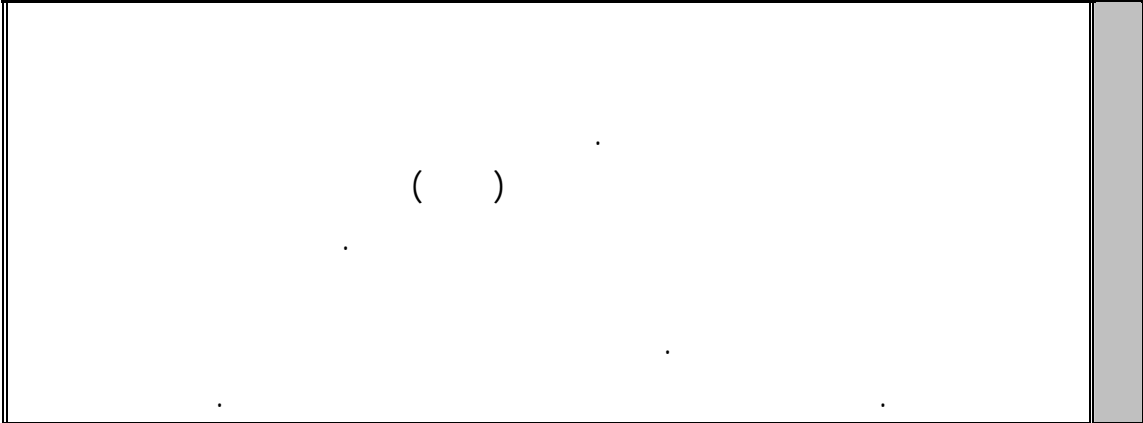
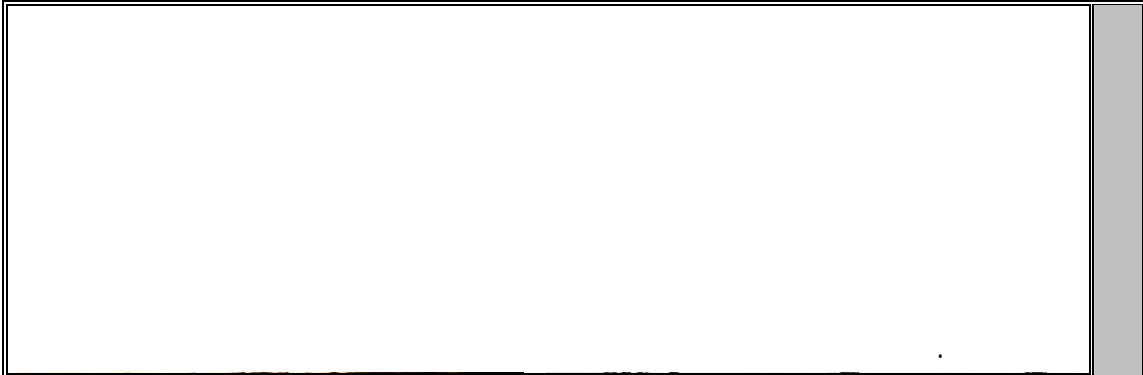

:
 :
 :
 :



:
 :
 :



:
 :
 :

() ()



()



: - - (Nubian Museum) - -

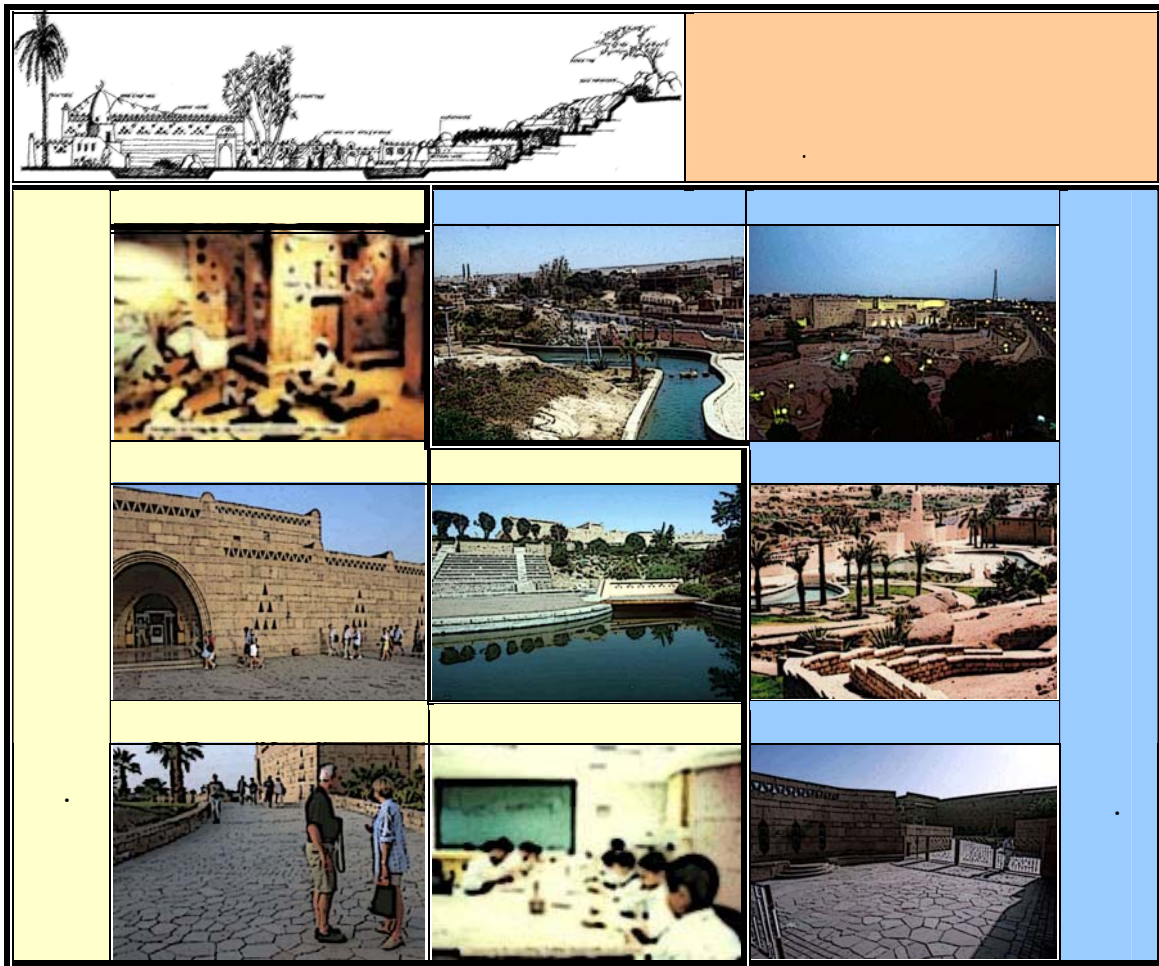

- - (Nubian Museum)

(-)

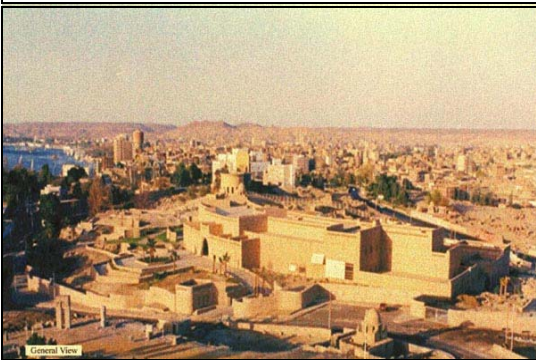
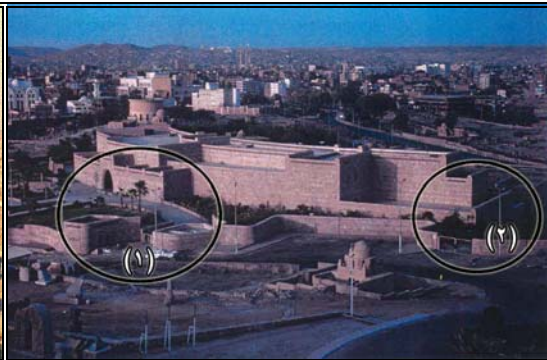
- (Nubian Museum) (-)	
/ . - . / . . :	. / . :
.(Site)	
) () () ()	
	

⁵ <http://www.nubamuseum.gov.eg/main.html>
http://archnet.org/library/sites/one-site.tcl?site_id=1319
The Aga Khan award for architecture, Architect's record, 2001 award cycle report.
 Google Earth.

. () () " " " "

. () () " " " "



()

()

()



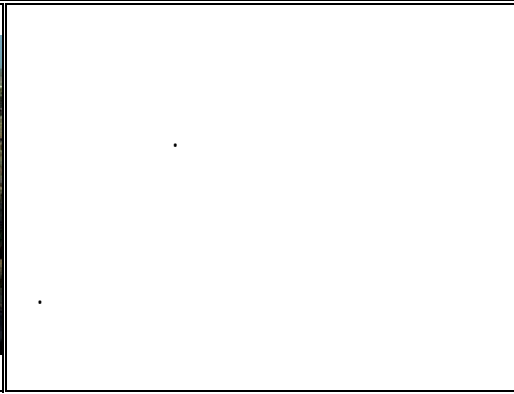
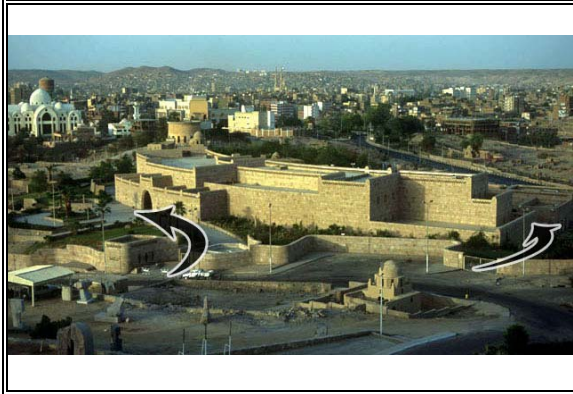

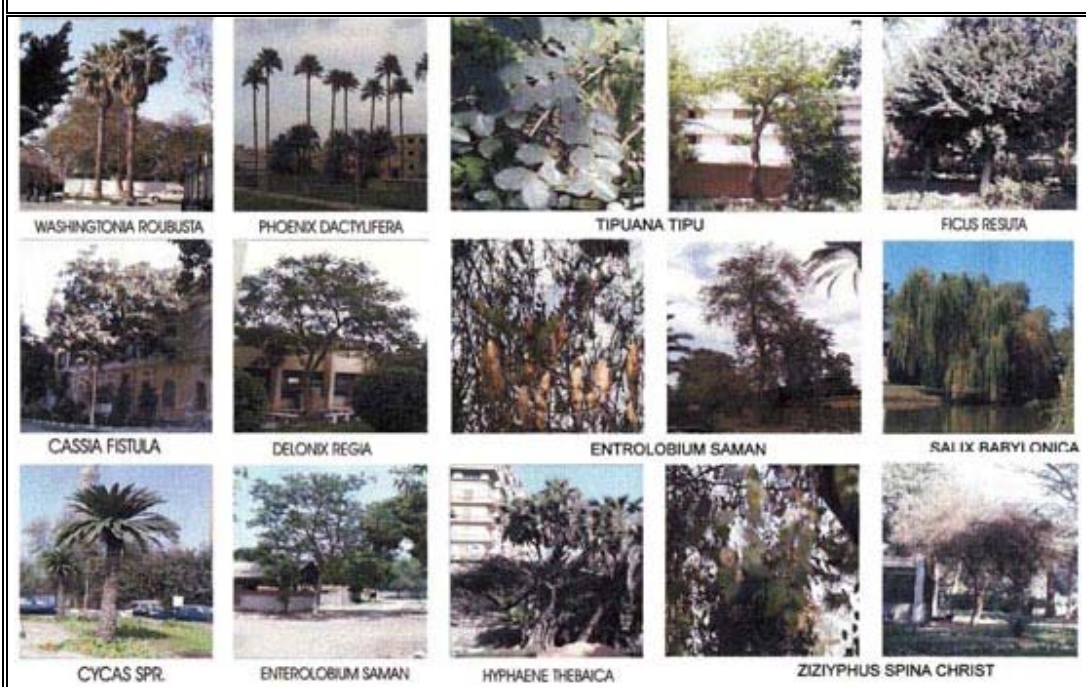

()

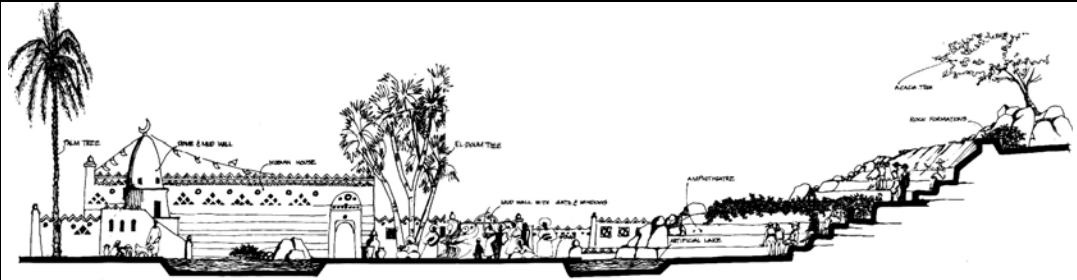
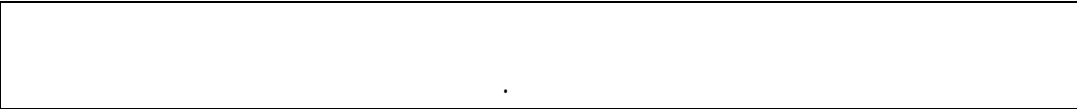
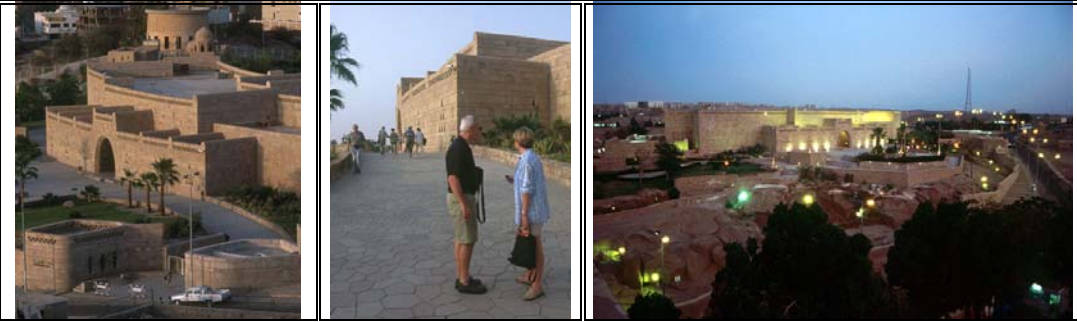
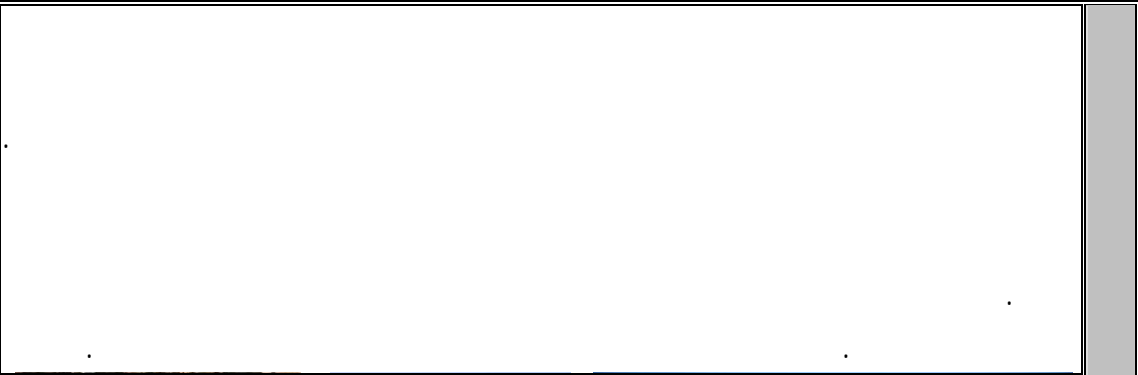





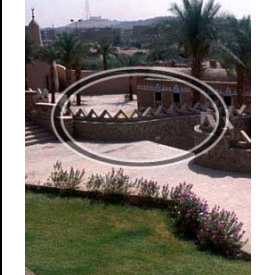
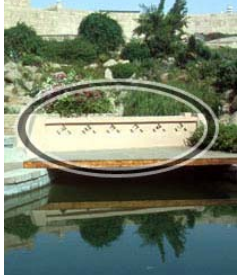





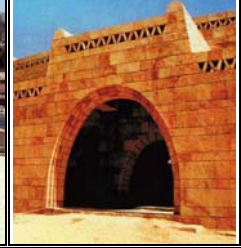



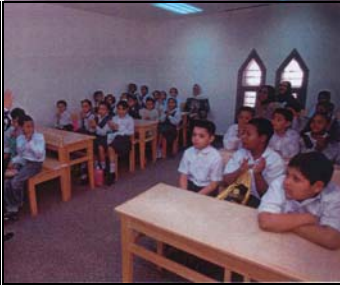

) ()
% % (





		:		
		:		
:		:		
				:
:		:		
		:		
		:		
		:		
		:		
		:		



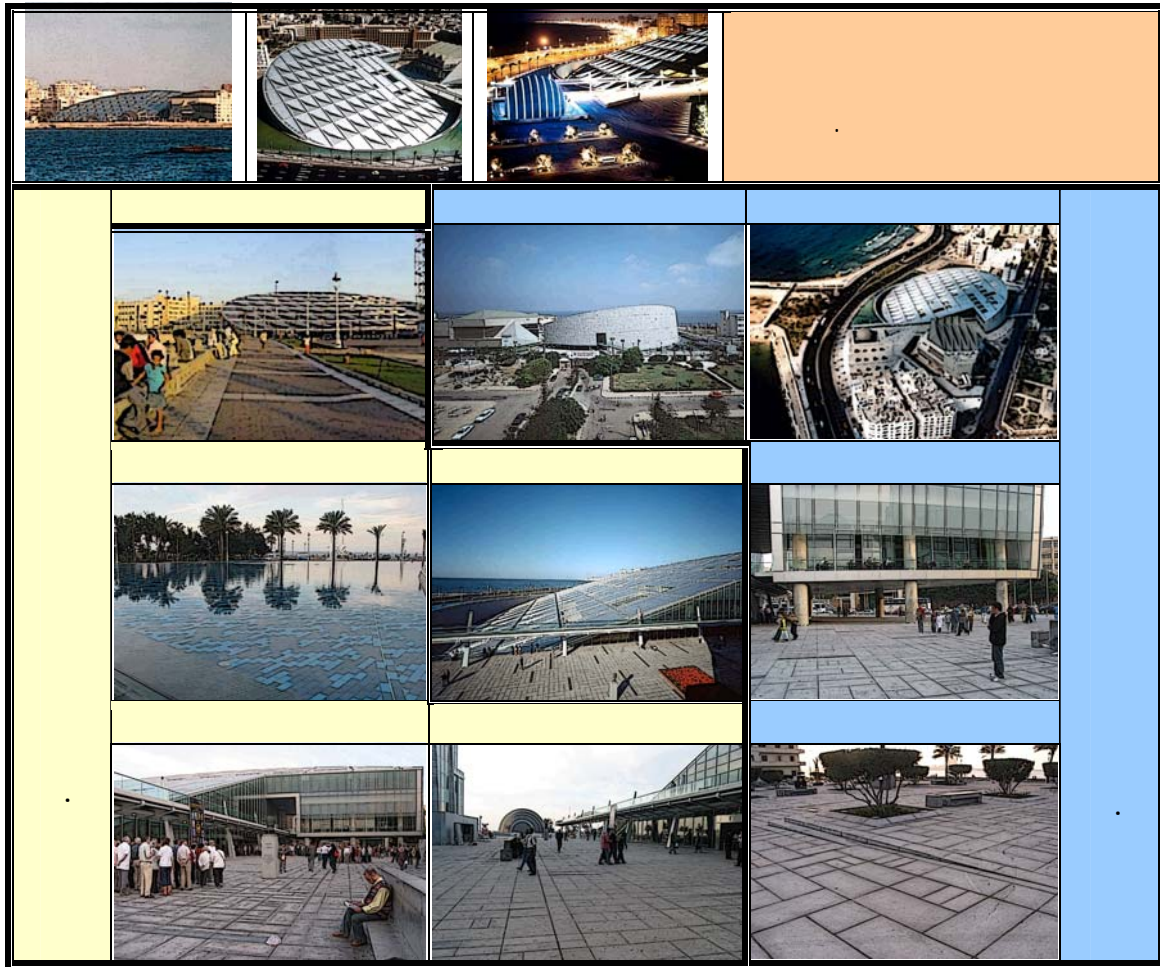

		
		
<p style="text-align: center;">:</p> <p style="text-align: center;">.</p> <p style="text-align: center;">:</p> <p style="text-align: center;">.</p> <p style="text-align: center;">()</p> <p style="text-align: center;">.</p> <p style="text-align: center;">()</p> <p style="text-align: center;">:</p> <p style="text-align: center;">.</p>		
		

: _ _ (Bibliotheca Alexandrina) - -



_ _ (Bibliotheca Alexandrina) (-)

(Bibliotheca Alexandrina)		(-)
(Snohetta)		:
		:
		
.()		
		

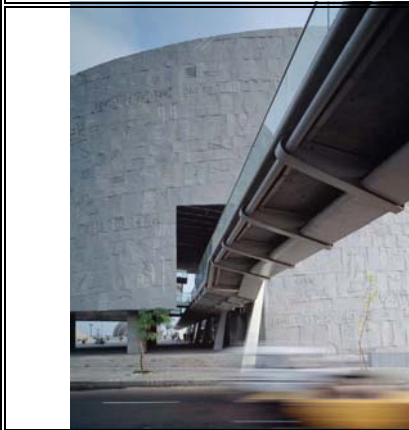

() ()

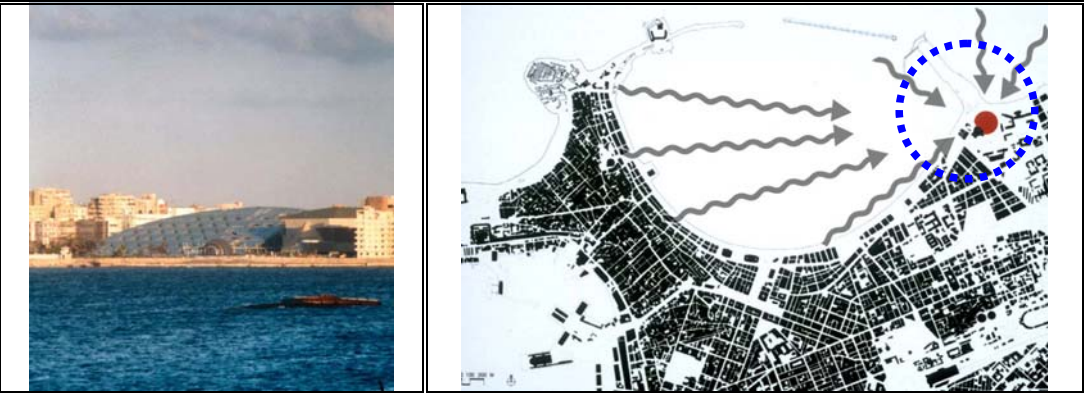
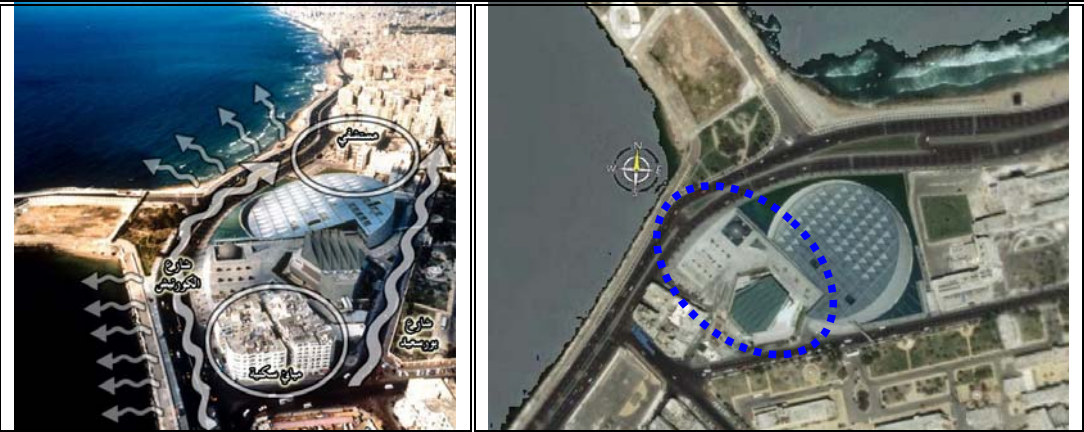

(° -°)

(° -°)

.(/)

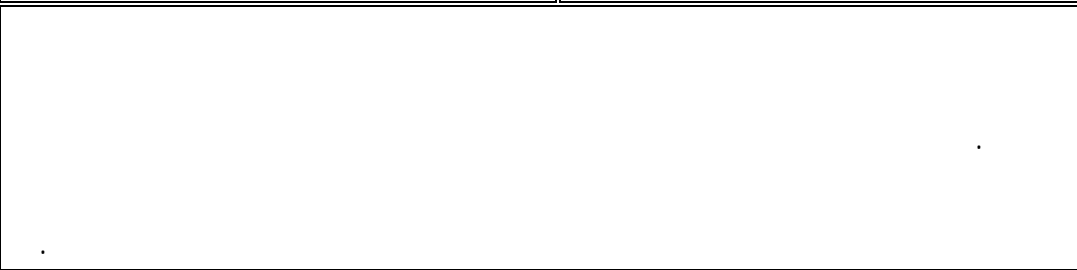
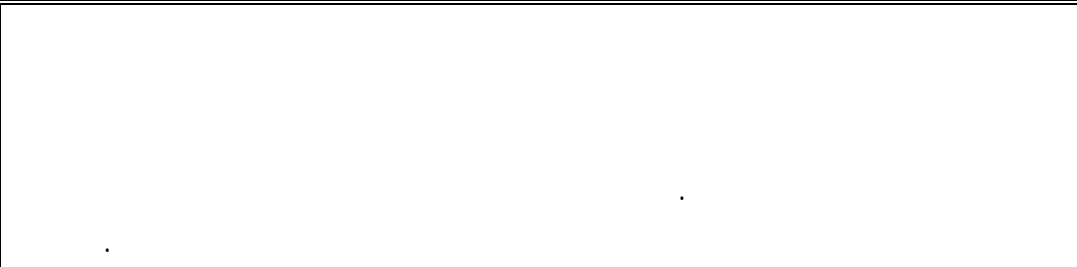

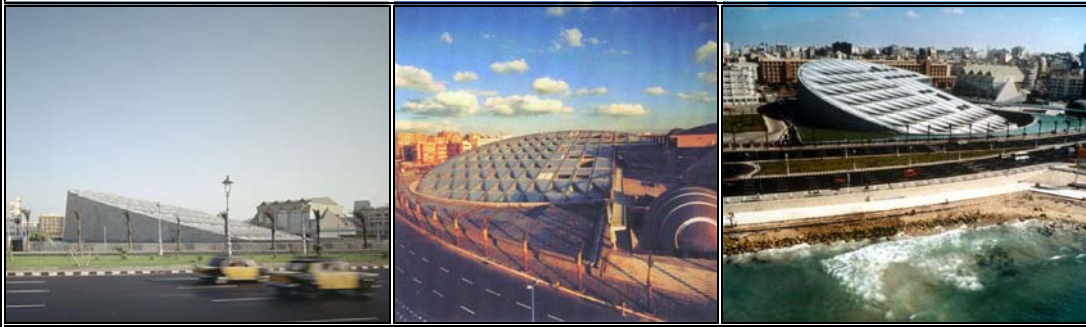



(- -)

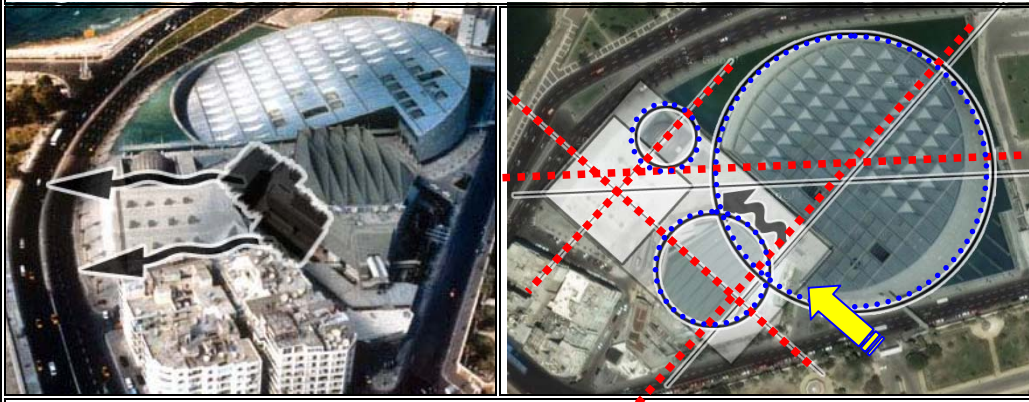



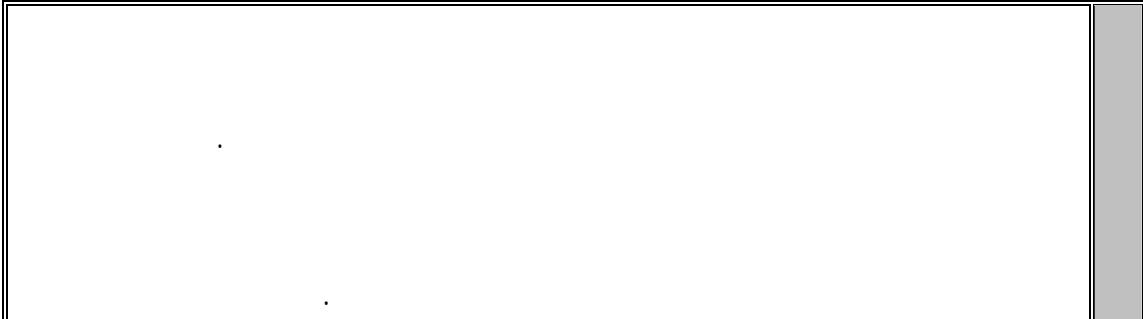

()

(. .)

(. .)



: _____
:
:
:
:



.

.



.()

: _____
:
:
:

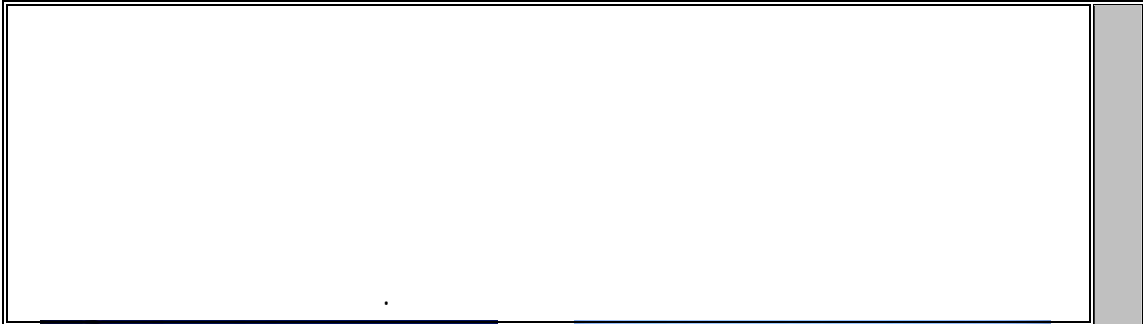

.



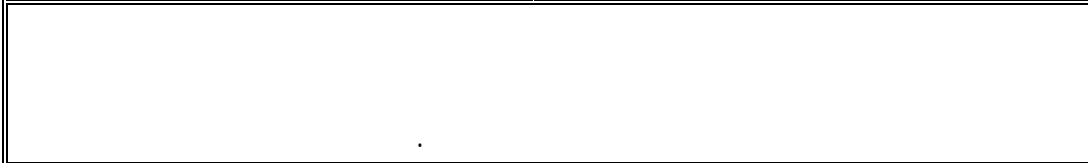



.

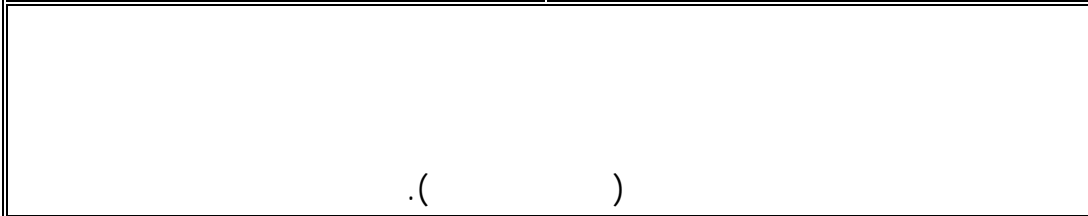







.

.



●	●	●	●	○	○			
●	●	●	●	●	●			
○	●	●	○	○	○			
●	●	●	●	●	●		()	
●	●	●	●	●	●			
●	●	●	●	○	●			
●	●	●	●	●	○			
○	●	●	○	○	○			
●	●	●	●	●	●			
●	○	●	●	○	○			
●	●	●	●	○	○			
●	●	●	●	●	○			
●	●	○	●	●	●			
○	●	●	●	○	●			
								

(● =) - (● =) - (○ =) (-)

<input type="radio"/>	<input checked="" type="radio"/>	<input checked="" type="radio"/>	<input type="radio"/>	<input type="radio"/>	<input checked="" type="radio"/>				
<input checked="" type="radio"/>	<input checked="" type="radio"/>	<input checked="" type="radio"/>	<input checked="" type="radio"/>	<input checked="" type="radio"/>	<input checked="" type="radio"/>				
<input checked="" type="radio"/>	<input checked="" type="radio"/>	<input checked="" type="radio"/>	<input type="radio"/>	<input type="radio"/>	<input checked="" type="radio"/>				
<input checked="" type="radio"/>	<input checked="" type="radio"/>	<input checked="" type="radio"/>	<input checked="" type="radio"/>	<input checked="" type="radio"/>	<input checked="" type="radio"/>				
<input checked="" type="radio"/>	<input checked="" type="radio"/>	<input checked="" type="radio"/>	<input checked="" type="radio"/>	<input checked="" type="radio"/>	<input checked="" type="radio"/>				
<input type="radio"/>	<input checked="" type="radio"/>	<input checked="" type="radio"/>	<input checked="" type="radio"/>	<input type="radio"/>	<input type="radio"/>				
<input checked="" type="radio"/>	<input checked="" type="radio"/>	<input checked="" type="radio"/>	<input checked="" type="radio"/>	<input checked="" type="radio"/>	<input checked="" type="radio"/>				
<input checked="" type="radio"/>	<input checked="" type="radio"/>	<input checked="" type="radio"/>	<input checked="" type="radio"/>	<input checked="" type="radio"/>	<input checked="" type="radio"/>				
<input type="radio"/>	<input type="radio"/>	<input checked="" type="radio"/>	<input checked="" type="radio"/>	<input checked="" type="radio"/>	<input checked="" type="radio"/>				
<input type="radio"/>	<input type="radio"/>	<input checked="" type="radio"/>	<input checked="" type="radio"/>	<input type="radio"/>	<input checked="" type="radio"/>				
<input checked="" type="radio"/>	<input checked="" type="radio"/>	<input checked="" type="radio"/>	<input checked="" type="radio"/>	<input checked="" type="radio"/>	<input checked="" type="radio"/>				
<input checked="" type="radio"/>	<input checked="" type="radio"/>	<input checked="" type="radio"/>	<input checked="" type="radio"/>	<input checked="" type="radio"/>	<input checked="" type="radio"/>)		
<input checked="" type="radio"/>	<input checked="" type="radio"/>	<input checked="" type="radio"/>	<input checked="" type="radio"/>	<input checked="" type="radio"/>	<input checked="" type="radio"/>)		
<input checked="" type="radio"/>	<input checked="" type="radio"/>	<input checked="" type="radio"/>	<input checked="" type="radio"/>	<input type="radio"/>	<input type="radio"/>				
<input checked="" type="radio"/>	<input checked="" type="radio"/>	<input checked="" type="radio"/>	<input checked="" type="radio"/>	<input checked="" type="radio"/>	<input checked="" type="radio"/>				
<input checked="" type="radio"/>	<input checked="" type="radio"/>	<input checked="" type="radio"/>	<input type="radio"/>	<input checked="" type="radio"/>	<input checked="" type="radio"/>				
<input checked="" type="radio"/>	<input checked="" type="radio"/>	<input checked="" type="radio"/>	<input checked="" type="radio"/>	<input checked="" type="radio"/>	<input checked="" type="radio"/>				
									

(●=)-(○=) (-)

:

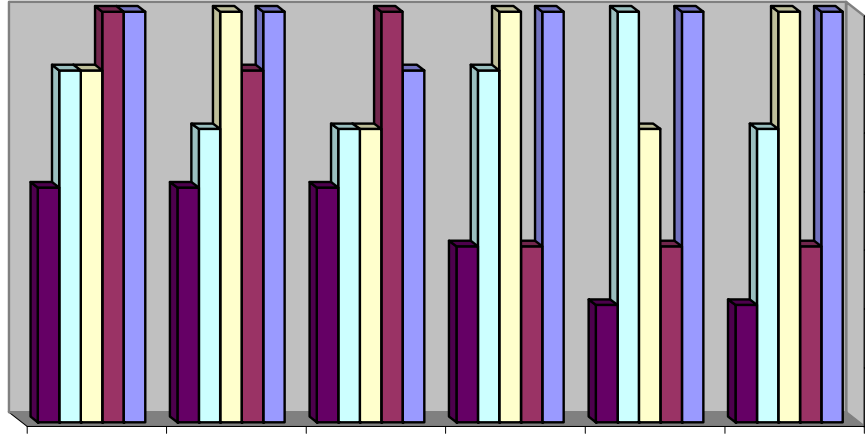

(-)

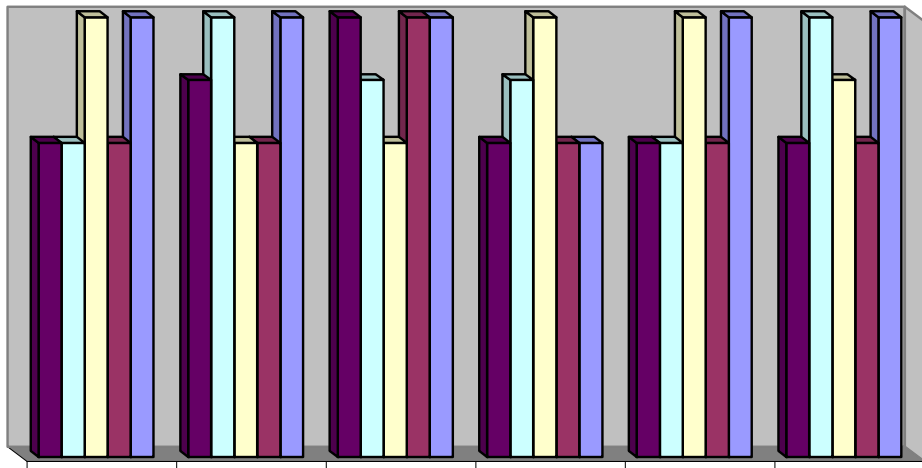

(-)

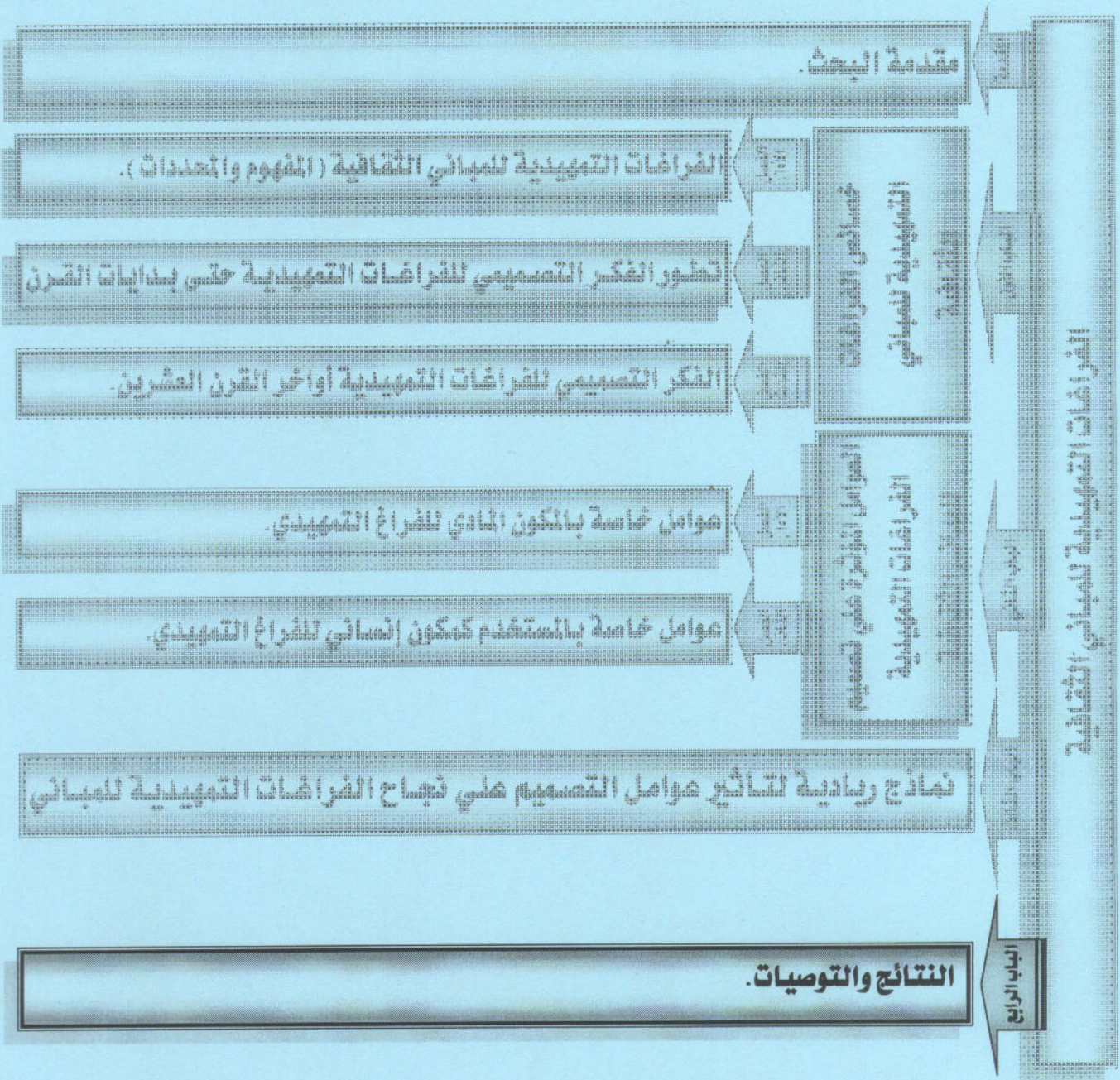

الباب الرابع: النتائج والتوصيات

١-٤- النتائج.

١-١-٤- نتائج الدراسة النظرية.

٢-١-٤- نتائج الدراسة التحليلية.

٢-٤- التوصيات.

١-٢-٤- توصيات عامة.

٢-٢-٤- توصيات خاصة عند تصميم مباني ثقافية جديدة.

٣-٢-٤- توصيات خاصة بالمباني الثقافية القائمة.

() ()

: - -

.

:

- - -

)

(

(*)

:

:

- - - -

:

•

•

•

*

()

()

:

:

•

•

-)

-

.(

•

•

•

•

•

•

•

•

()

()

:

- - - -

:

•

•

•

•

•

()

()

:

- - - -

-

:

-*

:

- - - -

:

:

)

.(

•

•

" "

)

.(

•

)

()

(

" "

" "

)

.(" "

:

:

•

•

:

:

()

•

.()

()

•

*

()

()

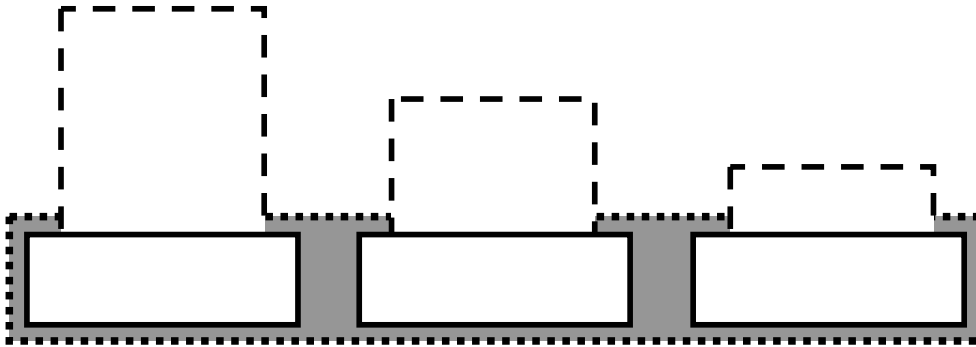

(-)

•

: :

:

(: ,)			
(:)			

()

()

(-)

(:)			
(:)			
(U)			
(U)			

(-)

()

()

:

-
-
-
-
-
-
-
-
-
-
-

: :

.()

()

()

:

- - - -

•

.

•

.

.

•

.

()

)

(

•

.

.()

)

•

.()

(

)

.

()

()

: - -

-

:

: - - -

•

-

-

-

-

•

-

-

•

•

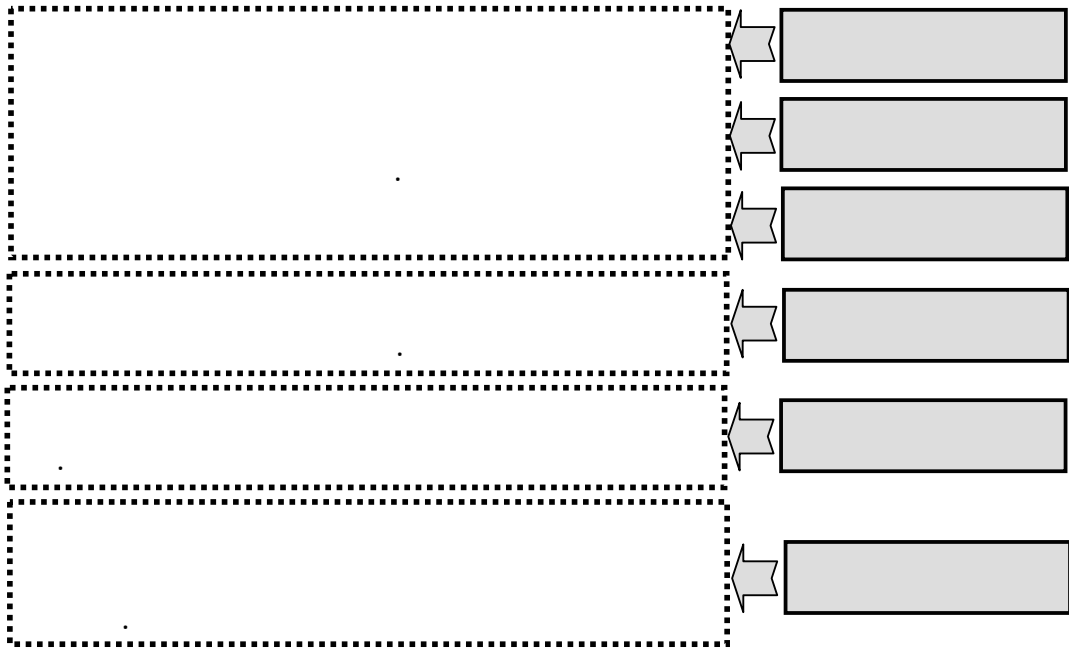

(-)

()

()

:

- - -

•

:

- - -

•

.

الفراغات التمهيدية للمباني الثقافية

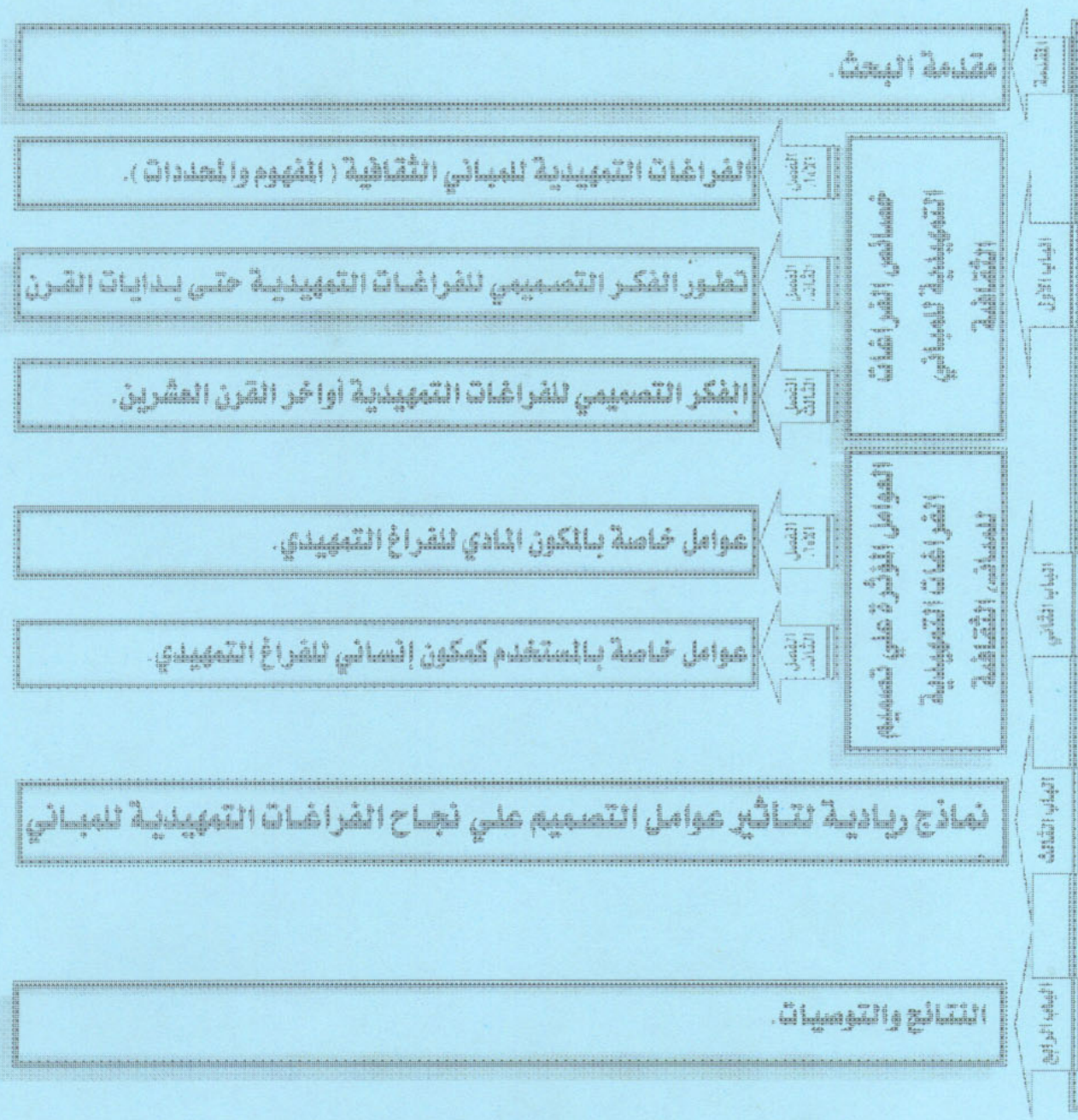

قائمة المراجع.

_____ " " (

_____ " " (

_____ " " (

_____ " " (

_____ " " (

_____ " " (

_____ " " (

_____ " " (

_____ " " (

_____ " " (

/ _____ " " (

_____ " " (

_____ " " (

_____ " " (

_____ " " (

_____(_____)_____ " " (

_____(_____)_____ " " (

_____ " " (

(

(

(

(

(

(

(

(

(

(

(

(

(

(

(

(

()

_____ " (

_____ " (

_____ " (

_____ " (

_____ " (

_____ " (

_____ " (

_____ " (

_____ " (

_____ " (

_____ " (

_____ " (

_____ " (

_____ " (

_____ " (

_____ " (

_____ " (

_____ " (

()

_____ :

" _____ " (

" _____ " (

" _____ " (

" _____ " (

" _____ " (

_____ :

" _____ " (

(-) " _____ " (

" _____ " (

" _____ " (

" _____ " (

" _____ " ()

" _____ " (

" _____ " ()

_____ :

" _____ " (

" _____ " (

_____ :

" _____ " (

" _____ " (

" _____ " (

" _____ " (

_____ :

1. Abdel Halim, Halim, "**El-Houd El Marsoud**", MIMAR 8: Architecture in Development, 1983.

2. Aga Khan Award for Architecture , **"Project summary of Cultural Park for Children"**, 1992.
3. Akbar, Jamel, **"Technical review of Cultural Park for Children "**, Aga Khan Award for Architecture, 1992.
4. Amin, M.K. ,**"Man, Environment and place Identity"**, An Environmental Design approach with Reference to the Egyptian Context, Unpublished PHD Thesis, Heriot-watt University, Edinburgh, England, 1994.
5. Alamuddin, Hana, **"Technical review of Bibliotheca Alexandrina"**, Aga Khan Award for Architecture, 2004
6. Auf, A.M., **"Authenticity and the Sense of place in Urban Design"**, Journal of urban Design, Vol. 6, No. 1., 2001.
7. Broto, Carles, **"urbanism"**,links international,spain.
8. Buttimer, A., **"Home, Reach, and the Sense of Place"**, In A. Buttimer and D. Seamon (eds), The Human Experience of Space, 1980, Croom Helm, London.
9. Carmona, M., **"Public Places Urban Spaces"**, Architecture Press, New York, 2003.
- 10.Cerver,F. Asensio, **"Urbanismo Squares"**, volume5, axis books,spain
- 11.Ching, Francis D.K. **"Architecture Form, Space and Order"**, Van nostrand Reinhold, New York,1979.
- 12.Cruickshank, Dan, **"A History of Architecture"**, Architecture Press, 20th edition.
- 13.Cullen, Gordon: **"Townscape"**, The Architecture Press, London, 1961.
- 14.De blij, H, **"Human Geography: Culture, Society and Space"**, John Wiley& Sons, USA, 1982.
- 15.Dee, Catherine, **"Form and Fabric in Landscape Architecture, A visual Introduction"**, spon Press, London, 2001.
- 16.Dixon, J. Morris, **"Urban spaces"**, Visual reference publication, New York, 1999.
- 17.El-Gohary, Germin, **"Urban Glow A study of squares at night"**, First Ain-Shams conference of Architecture Urbanism and Culture, 2006.
- 18.Fabian, A.K., **"Place-Identity: Physical World Socialization of the Self Readings in Environmental Psychology: Giving Places Meaning"**, Academic Press Limited, London, 1995.
- 19.Francisco A. Cerver ,**"Redesigning City Squares and Plazas"**, Arco for Hearst Books international, New York,1997.
- 20.Gehl, Jan, **"Life Between Buildings"**, Van Nostrand Reinhold Company, New York, 1987.
- 21.Global Architecture. **"Centre Georges Pompidou"**, Tokyo, (1977).
- 22.Henderson, J., **"Museum Architecture"**, Rockport publishers, USA,(1998).
- 23.Hough, M., **"Out of Place, Restoring Identity to the Regional Landscape"** Yale University Press, 1990, New Haven and London.
- 24.Hourston, L., **"Museum Builders2"**, Wiley-Academy, Britain,(2004).
- 25.I, Bentley, **"Responsive environment"**, Butterworth Architecture,1996.
- 26.J. McCluskey, **"Road form & Townscape"** ,Butterworth Architecture, 2nd edition, London, 1992.
- 27.Jackson, J. B., **"Vernacular space"**, Texas Architecture,(1985).

-
-
- ()
28. Jeremy, M., **"New Public Architecture"**, Calmann & King Ltd, London, (1996).
 29. Lang, Jon, **"Urban design: The American Experience"**, Van Nostrand Reinhold, New York, 1994.
 30. Lawson, Bryan, **"The Language of Space"** Architectural Press, U.S.A., 2001.
 31. Lindey, N. "Drawing Socio-economic lines in central park ", Landscape Architecture, (1977).
 32. Lynch, Kevin, **"A theory of good City Form"**, Cambridge ,MA: MIT press, (1981).
 33. Lynch, K., **"Site Planning"**, Cambridge ,MA: MIT press,
 34. Lynch, K. **"The image of the city"**, Cambridge MIT Press, USA, (1963).
 35. M. Francis, **" Public Space"**, Cambridge University press, 2nd edition, New York, 1995.
 36. Mahyer, A., **"Non-place and Placelessness as Narratives of loss: rethinking the Notion of place"**, Journal of urban design, Vol. 4, No. 2, 1999.
 37. Marcus, C. Cooper, **"People Places"**, Second edition, John Wiley & Sons, New York, (1998).
 38. Newton, T. Norman, **"Design on the land"**, Harvard university press, U.S.A., 1971.
 39. Norberg-Schulz, C., **"Existence, Space and Architecture"**, 1971, Praeger, New York.
 40. Norman, K. Booth, **"Basic Elements of Landscape Architectural Design"**, Waveland Press, Reissue edition, 1989.
 41. Piotrowski, M. Christine, **"Designing Commercial Interiors"**, John Wiley & Sons, New York, 1999.
 42. Rapoport, A. **"The meaning of the built environment: A nonverbal communication approach "**, Beverly Hills. Calif: Sage, (1982).
 43. Relph, E., **"Place and Placelessness"**, Pion Limited, 1976, London.
 44. Relph, E., **"The Instant Environment Machine and the Reclamation of Place"**, Plenary Paper, "Place and Place Making Conference", Paper 85, 1985, Melbourne, Australia.
 45. Rowell, K., **"Richard Rogers Complete Works"**, Phaidon Press, UK, (1999).
 46. Salama, A.M., **"Human Factors in Environmental Design"**, An introductory Approach to Architecture, The Anglo Egyptian bookshop, 1998, Cairo, Egypt.
 47. Seton, Lloyd, et. al, **"Ancient Architecture"**, Harry N. Abrams, New York, U.S.A., 1974.
 48. Simonde, J. O., **"Landscape Architecture"**.
 49. Spreiregen, Paul, **"Urban Design: The Architecture of Town and Cities"**, McGraw-Hill Co., New York, 1965
 50. Steele, J., **"Architecture Today"**, Phaidon Press, USA, (1997).
 51. Stevenson, Neil, **"Annotated Guides Architecture"** DK publishing, Italy, 1984.
 52. Stevenson, Neil, **"Design of Urban Spaces An Inquiry into a Socio-spatial Process"** John Wiley & Sons, UK, 1996.

-
-
53. **The Aga Khan award for architecture**, Architect's record, 2001 award cycle report.
54. The Greater London Council Study: "**An Introduction to Housing Layout**", The Architecture Press, London, 1980.
55. "**Theatre & Halls**", Meisei Publications, Japan, (1995).
56. Tuan, Yi-Fu., "**Space and Place: The Perspective of Experience**", 1977, Minneapolis: University of Minnesota Press.
57. Whyte, W.H. "**The Social life of small urban spaces**", Washington, D.C.: the conservation foundation, (1980).

Google Earth (

<http://archnet.org>

http://archnet.org/library/documents/one-document.tcl?document_id=4466

http://archnet.org/library/sites/one-site.tcl?site_id=1319

http://archnet.org/library/sites/one-site.tcl?site_id=

<http://www.arcaid.captureweb.co.uk/feature.asp?JobNo=290>

<http://www.arksite.dk/wm142098>

<http://www.art-entreprise.com/html/placterr.htm>

http://www.beyeler.com/fondation/e/html_01start/01_sta_main.php

<http://www.bibalex.org/arabic/index.aspx>

<http://www.carfree.com>

<http://www.civilization.ca/indexe.asp>

<http://www.cnac-gp.fr/pompidou/Communication.nsf>

<http://www.edo-tokyo-museum.or.jp/english/index.html>

<http://www.getty.edu/>

http://www.greatbuildings.com/buildings/Pyramide_du_Louvre.html

<http://www.highwaygold.co.uk/regional/europe/france/lyons/terreaux/>

<http://www.henryart.org/>

http://www.louvre.fr/llv/commun/home_flash.jsp

http://www.lyon-photos.com/diaporama/index_terreaux_7.html

http://www.mediajoy.com/chikatsu/index_e.html

<http://www.musuka.com/~ueken/tando0016.html>

<http://www.naoshima-is.co.jp/english/first.html>

<http://www.ncartmuseum.org/museumpark/events.shtml>

<http://www.nms.ac.uk/scotland/home/index.asp>

<http://www.nubamuseum.gov.eg/main.html>

<http://www.pacifico.co.jp/english/>

<http://www.sfmoma.org/>

<http://www.student.tue.nl/t/b.j.h.muskens/urbanform.htm>

<http://www.suntory.com/culture-sports/smt/>

<http://classes.uleth.ca/200103/art2850b/louvre.html>

<http://www.vulcania.com/2005/anglais/>

permanent and variable characteristics of the approach spaces of the cultural buildings which distinguish these spaces and help in performing its function.

The research deals with studying of the cultural buildings approach spaces characteristics. then, identifying the factors that affects designing these spaces and testing the effect of these factors on a group of successful cultural facilities in performing its cultural message.

The research reached to, That sitting the physical factor into consideration affects performing the space's function, whereas the human factors -especially society culture- controls providing the space its interactive nature. And reflects with an effective way on the space success in performing its message and attracting an increasing numbers of users to promote the cultural activity within the local societies.

ABSTRACT

Culture represents issues of the interaction between man and environment since years ago and one of the concepts which related to man and distinguishing him from the other creatures. In General, the culture term doesn't districted only on the intellectual or literal & artistic production of the society, and it isn't theoretical information or intellectual speeches but it's concept exceeded this to include every activity which enriches the heritage and the spiritual values of the society.

As civilization related to facilities and instructions whether it was residential or public, the space has it's essential & great influence in the society and its public activities. Firstly, public space was related to the religious facilities and the places of public festivals according to the importance of the public meetings in forming the personality and identity of the society, and according to the importance of the psychological role of the cultural building and the emphasizing on the values represented by it's architectural shape and its context in which affects the society and influenced with it. Thus, the visual effect on the audience begins with the approach to the cultural building through it's approach spaces which represents a rich field to transform inspirations and emphasizing the requested meaning, also, controlling the activities and identifying the dealing style with the building in addition to the functional side through flexible movement and increasing safety factor.

The research problem is that the approach spaces for the modern cultural buildings didn't develop as the same of cultural development with its interactive style which depends on the users of the space as participant and not recipient. And It's role still restricted on performing the ordinary functional side which loses these spaces a great part from its cultural message.

The research aims to recognize the effective factors on designing approach spaces of the cultural buildings and it's effect on the success of the cultural facilities, performing its function and the cultural activity for the society to select the main factor that affects the design success. Also identifying the

Examination Committee

Thesis title: **The Approaches of Cultural Buildings**
(Analytical study of design principles)

Researcher name: **Mohamed Ali Mohamed Khalil**

Supervisors

name	profession	signature
Ass. Prof. Dr.\ Osama M. A. Farag	Associate prof. of Architecture Faculty of Engineering Mansoura University	
Ass. Prof. Dr.\ Mohamed M. T. El-Azab	Associate prof. of Architecture Faculty of Engineering Mansoura University	

Examination Committee

name	profession	signature
Prof. Dr.\ Mohamed Salah El-Deen El-Sayed	prof. of Architecture Faculty of Engineering Mansoura University	
Prof. Dr.\ Mohamed Aasm Mahmoud Hanafy	prof. of Architecture Faculty of Engineering Alexandrina University	
Ass. Prof. Dr.\ Osama M. A. Farag	Associate prof. of Architecture Faculty of Engineering Mansoura University	
Ass. Prof. Dr.\ Mohamed M. T. El-Azab	Associate prof. of Architecture Faculty of Engineering Mansoura University	

Dep. Head

Vice – Dean

Dean

Supervisors

Thesis title:

The Approaches of Cultural Buildings **(Analytical study of design principles)**

Researcher name:

Mohamed Ali Mohamed Khalil

Supervisors

name	profession	signature
Ass. Prof. Dr.\ Osama M. A. Farag	Associate prof. of Architecture Faculty of Engineering Mansoura University	
Ass. Prof. Dr.\ Mohamed M. T. El-Azab	Associate prof. of Architecture Faculty of Engineering Mansoura University	

Dep. Head

Vice – Dean

Dean



Mansoura University
Faculty of Engineering
Department of architecture

The Approaches of Cultural Buildings

(Analytical study of design principles)

A Thesis Submitted to the Department of Architecture
In Partial Fulfillment of the Requirements
for the Degree of Master of Science in Architecture

Presented by

Architect/ Mohamed Ali Mohamed Khalil

A demonstrator in the Department of architecture
Faculty of Engineering- Mansoura University

Supervisors

Dr. Mohamed Mohamed
Taha El-Azab

Associate prof. of Architecture
Faculty of Engineering
Mansoura University

Dr. Osama Mohamed Ali
Farag

Associate prof. of Architecture
Faculty of Engineering
Mansoura University

2006